

YAMAHA
FC9
FOOT CONTROLLER

OWNER'S MANUAL

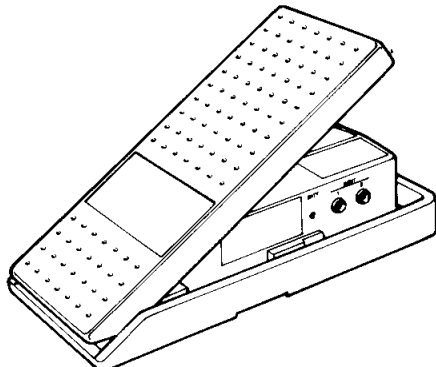

PRECAUTIONS

PLEASE READ CAREFULLY BEFORE PROCEEDING

* Please keep these precautions in a safe place for future reference.



WARNING

Always follow the basic precautions listed below to avoid the possibility of serious injury or even death from electrical shock, short-circuiting, damages, fire or other hazards. These precautions include, but are not limited to, the following:

- Do not open the instrument or attempt to disassemble the internal parts or modify them in any way. The instrument contains no user-serviceable parts. If it should appear to be malfunctioning, discontinue use immediately and have it inspected by qualified Yamaha service personnel.
- Do not expose the instrument to rain, use it near water or in damp or wet conditions.
- If the AC adaptor cord or plug becomes frayed or damaged, or if there is a sudden loss of sound during use of the instrument, or if any unusual smells or smoke should appear to be caused by it, immediately turn off the power switch, disconnect the adaptor plug from the outlet, and have the instrument inspected by qualified Yamaha service personnel.
- Use the specified adaptor (PA-1/1B, PA-3B, or an equivalent recommended by Yamaha) only. Using the wrong adaptor can result in damage to the instrument or overheating.
- Before cleaning the instrument, always remove the electric plug from the outlet. Never insert or remove an electric plug with wet hands.
- Check the electric plug periodically and remove any dirt or dust which may have accumulated on it.



CAUTION

Always follow the basic precautions listed below to avoid the possibility of physical injury to you or others, or damage to the instrument or other property. These precautions include, but are not limited to, the following:

- Do not place the AC adaptor cord near heat sources such as heaters or radiators, and do not excessively bend or otherwise damage the cord, place heavy objects on it, or place it in a position where anyone could walk on, trip over, or roll anything over it.
- When removing the electric plug from the instrument or an outlet, always hold the plug itself and not the cord.
- Do not connect the instrument to an electrical outlet using a multiple-connector. Doing so can result in lower sound quality, or possibly cause overheating in the outlet.
- Unplug the AC power adaptor when not using the instrument, or during electrical storms.
- Always make sure all batteries are inserted in conformity with the +/- polarity markings. Failure to do so might result in overheating, fire, or battery fluid leakage.
- Do not dispose of batteries in fire.
- Do not attempt to recharge batteries that are not intended to be charged.
- If the instrument is not to be in use for a long time, remove the batteries from it, in order to prevent possible fluid leakage from the battery.
- Keep batteries away from children.
- Before connecting the instrument to other electronic components, turn off the power for all components. Before turning the power on or off for all components, set all volume levels to minimum.
- Do not expose the instrument to excessive dust or vibrations, or extreme cold or heat (such as in direct sunlight, near a heater, or in a car during the day) to prevent the possibility of panel disfiguration or damage to the internal components.
- Do not use the instrument near other electrical products such as televisions, radios, or speakers, since this might cause interference which can affect proper operation of the other products.
- Before moving the instrument, remove all connected adaptor and other cables.
- When cleaning the instrument, use a soft, dry cloth. Do not use paint thinners, solvents, cleaning fluids, or chemical-impregnated wiping cloths. Also, do not place vinyl or plastic objects on the instrument, since this might discolor the panel.
- Do not rest your weight on, or place heavy objects on the instrument, and do not use excessive force on the buttons, switches or connectors.
- Do not operate the instrument for a long period of time at a high or uncomfortable volume level, since this can cause permanent hearing loss. If you experience any hearing loss or ringing in the ears, consult a physician.

Yamaha cannot be held responsible for damage caused by improper use or modifications to the instrument.

Always turn the power off when the instrument is not in use.

Make sure to discard used batteries according to local regulations.

● INTRODUCTION

Thank you for purchasing the Yamaha FC9 foot controller. While the FC9 can be used to control the volume of two separate instruments, it also features an electronic volume control circuit which makes CV control possible.

In order to properly understand the FC9's features as well as enjoy years of trouble free operation, please read this manual carefully.

● CONTENTS

PRECAUTIONS	2
OPERATION OF THE FC9	3
POWER	5
REPLACING BATTERY	5
LABELLING BY FUNCTION	7
BLOCK DIAGRAM	7
SPECIFICATIONS	8

PRECAUTIONS

- Shocks and drops may damage the FC9, and can adversely affect its performance. Handle carefully, and avoid rough treatment.
- For AC operation, use of the PA-1, PA-1B, or PA-3B AC adaptor is strongly recommended. Other adaptors may differ in voltage and/or polarity, and could damage the FC9 when used.
- When you won't be using the FC9 for a extended period of time, make sure to remove the battery to prevent the possibility of damage caused by battery leakage.
- When plugs are inserted into inputs 1 and/or 2, the power is automatically turned on. Be sure to unplug the inputs when the FC9 isn't being used to conserve the battery.
- When the BATT indicator dims or doesn't light, it's time to replace the battery (006P/9V). Refer to "Replacing Battery" on page 5.
- Clean the FC9 with a soft cloth. Avoid using benzene, alcohol-based cleaners, or aerosol cleaners at close range because they may permanently damage the finish.

OPERATION OF THE FC9

- Use as a volume controller

The FC9 can simultaneously control the volume of two separate instruments.

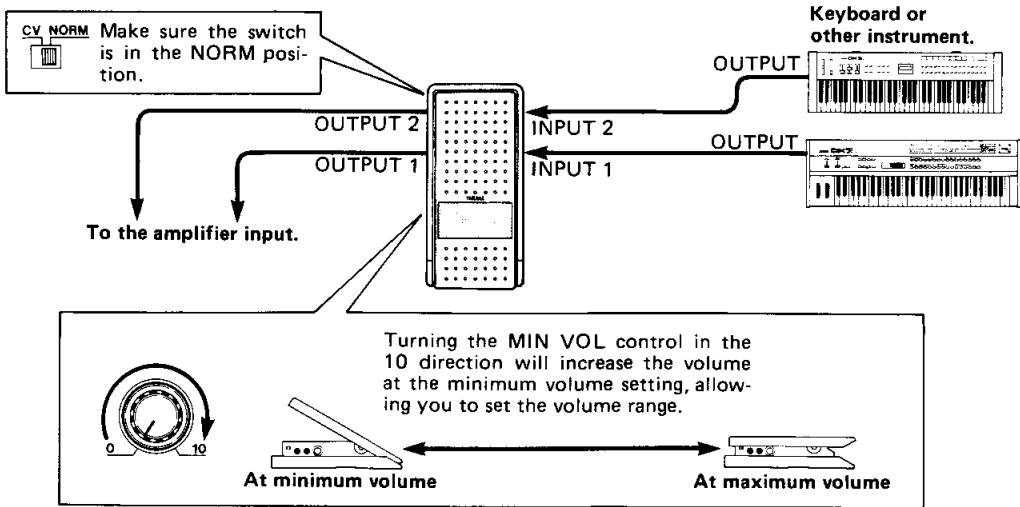

- Signals fed into INPUT 1 are output through OUTPUT 1; INPUT 2 is output through OUTPUT 2. Connections are made with standard phone plugs.

- Use as a CV controller

The FC9 can also be used to control the modulation and the volume of synthesizers and other electronic instruments.

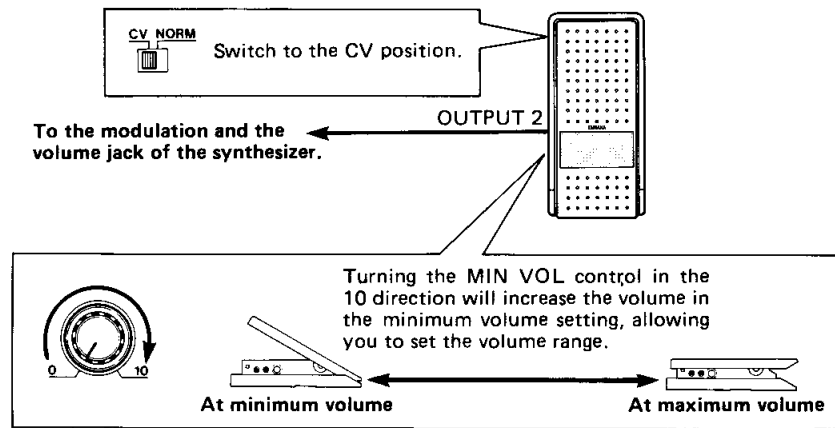

- Use Output 2 when using the FC9 as a CV controller. The standard stereo phone plug cord available on the market is necessary.
- Input 1/Output 1 can still be used for volume control when the FC9 is being used as a CV controller.

POWER

The FC9 operates on a common nine volt (006P) battery, and can also be operated with the optional AC adaptor which plugs into any AC outlet.

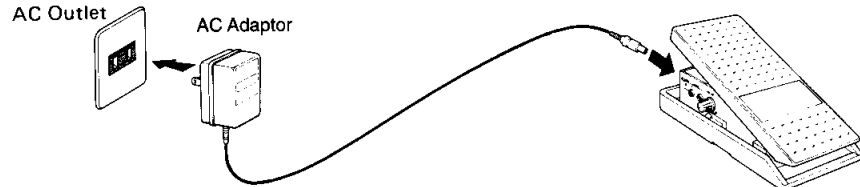

- When a battery is inserted and the AC adaptor is plugged in, the FC9 is powered by the adaptor.

REPLACING BATTERY

- ① Loosen the hook screw on the underside of the FC9 and remove the base.

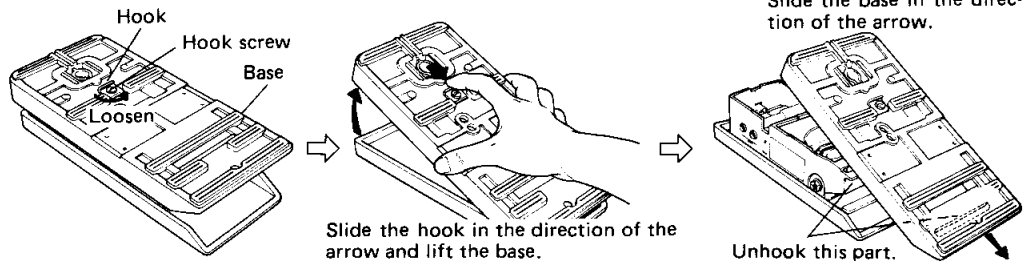

- ② Remove the old battery and replace it with a new one.

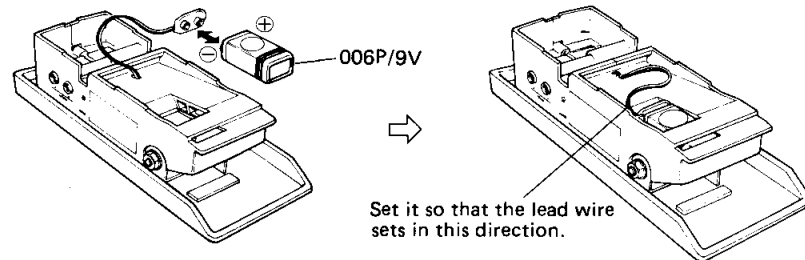

- ③ Reattach the base.

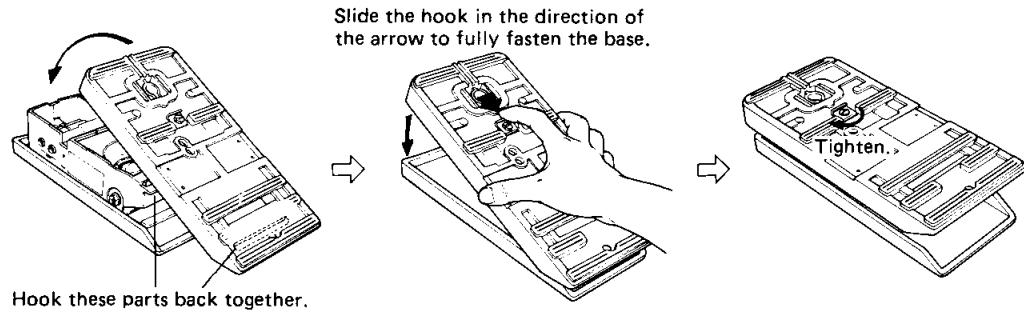

LABELLING BY FUNCTION

When using several FC9 foot controllers, you may want to label each pedal by its function.

Write the function of the pedal (e.g. VOLUME, MODULATION) on a piece of tape and stick it on this area.

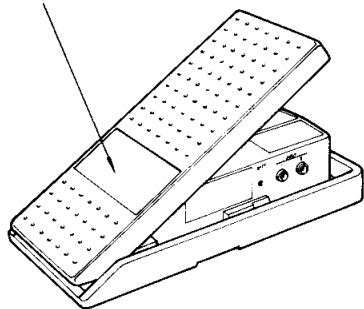

BLOCK DIAGRAM

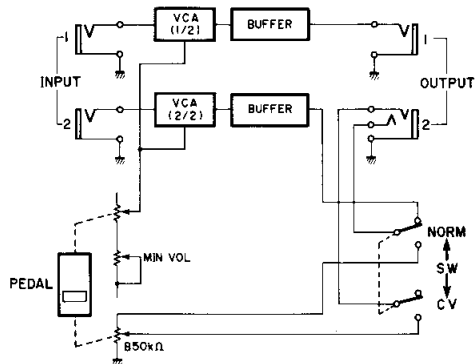

SPECIFICATIONS

Pedal angle	30°
NORM position	
Maximum input level	+8 dBm (9V battery use)
Input impedance	10 kohms
Resistance at MAX position	0 dB
Resistance at MIN position	-20 dB (MIN VOL "10" setting)
Output impedance	-70dB or greater (MIN VOL "0" setting)
Input-output phase	560 ohms
CV position output characteristics	in-phase
LED	B50k ohms (stereo phone plug inserted into Output 2 jack)
Power requirements	Battery indicator
Battery (006P)	9 V
AC adaptor (PA-1B)	12 V
Power consumption	5mA
Dimensions (W x H x D)	116mm x 62mm x 246mm (4-1/2" x 2-1/2" x 9-5/8")
Weight	1.3 kg (2.9 lbs)
Supplied accessories	9V battery (006P) x 1
	Owner's manual



VD69030 906POCP5.2-02B0

M.D.G., EMI Division
© Yamaha Corporation 1993
Printed in Japan