



NS-P80

(NS-P80: NS-E56 + NS-C55)

HOME CINEMA CENTER & EFFECT SPEAKERS

SYSTEME D'ENCEINTES CENTRALE ET D'EFFETS AUDIO/VIDEO

**OWNER'S MANUAL
MODE D'EMPLOI**

PRECAUTIONS

Read this before using the speaker.

- To assure the finest performance, please read this manual carefully. Keep it in a safe place for future reference.
- Install the speaker in a cool, dry, clean place - away from windows, heat sources, sources of excessive vibration, dust, moisture and cold. Avoid sources of humming (transformers, motors). To prevent fire or electrical shock, do not expose the speaker to rain or water.
- To prevent the enclosure from warping or discoloring, do not place the speaker where it will be exposed to direct sunlight or excessive humidity.
- Do not place the following objects on the speaker:
 - Glass, china, etc.
If glass etc. falls by vibrations and breaks, it may cause personal injury.
 - A burning candle etc.
If the candle falls by vibrations, it may cause fire and personal injury.
 - A vessel with water in it
If the vessel falls by vibrations and water spills, it may cause damage to the speaker, and/or you may get an electric shock.
- Do not place the speaker where foreign objects such as water drips might fall. It might cause a fire, damage to the speaker, and/or personal injury.
- Do not place the speaker where it is liable to be knocked over or struck by falling objects. Stable placement will also ensure better sound performance.
- Placing the speaker on the same shelf or rack as the turntable can result in feedback.
- Never put a hand or a foreign object into the port located on the rear of the speaker as this might cause personal injury and/or damage to the speaker.
- When moving the speaker, do not hold the port as it might cause personal injury and/or damage to the speaker.
- Any time you note distortion, reduce the volume control on your amplifier to a lower setting. Never allow your amplifier to be driven into "clipping". Otherwise the speaker may be damaged.
- When using an amplifier with a rated output power higher than the nominal input power of the speaker, care should be taken never to exceed the speaker's maximum input.
- Do not attempt to clean the speaker with chemical solvents as this might damage the finish. Use a clean, dry cloth.
- Do not attempt to modify or fix the speaker. Contact qualified Yamaha service personnel when any service is needed. The cabinet should never be opened for any reasons.
- **Secure placement or installation is the owner's responsibility. Yamaha shall not be liable for any accident caused by improper placement or installation of the speaker.**

COMPONENTS OF THE PACKAGE

The speaker package "NS-P80" is designed for use in a multi-channel audio system such as a home theater system. The package includes four surround/surround back speakers (NS-E56) and one center speaker (NS-C55).

<NS-E56>

2-way acoustic-suspension speaker system used for the surround and surround back speakers

<NS-C55>

2-way acoustic-suspension speaker system used for the center speaker

CONTENTS

UNPACKING	1
SETTING UP THE SPEAKERS	2
Placing the center speaker	3
Mounting the surround and surround back speakers on the wall	3

CONNECTIONS	4
An example of basic connections	4
Connecting speaker cables	5
SPECIFICATIONS	6

UNPACKING

After unpacking, check that the following items are contained.

- Surround/surround back speakers

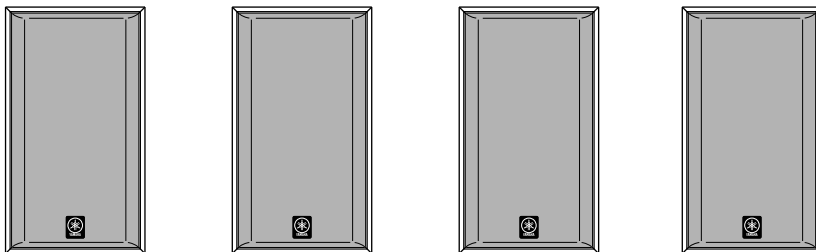

<NS-E56>

- Center speaker



<NS-C55>

- Speaker cable (10 m) × 4

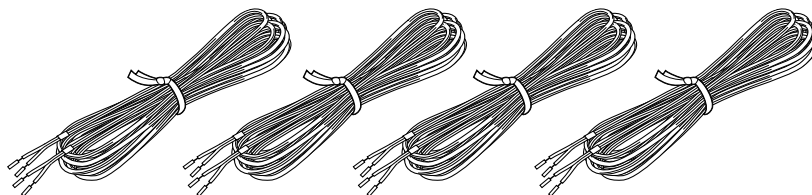

- Speaker cable (4 m) × 1

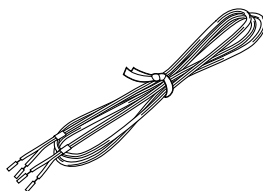

- Fastener × 2

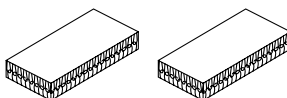

SETTING UP THE SPEAKERS

Before making connections, place all speakers in their respective positions. The positioning of the speakers is important because it controls the whole sound quality of this system.

Place the speakers depending on your listening position by following the instructions below.

Speaker configuration

The surround and surround back speakers are used for surround sounds, and the center speaker is for center sounds (dialog etc.).

Note

In this speaker package, the same speakers (NS-E56) are used for the surround and surround back speakers.

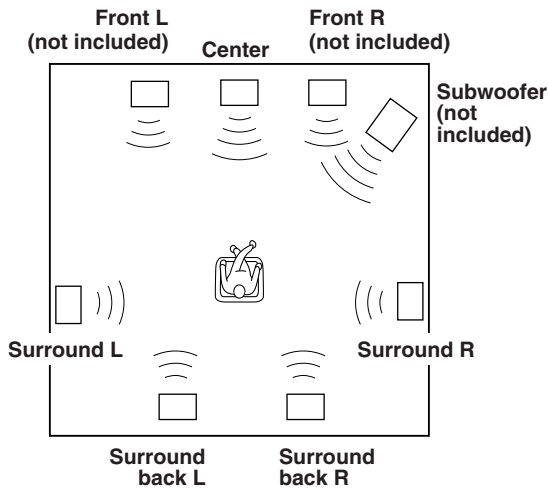

Placing speakers

Surround speakers:

Place on the side of or slightly behind your listening position, facing slightly inward. About 1.8 m (approx. 6 feet) from the floor.

Center speaker:

Place between the front speakers.

Surround back speakers:

Place behind your listening position, facing slightly inward. Adjust the vertical position with the surround speakers.

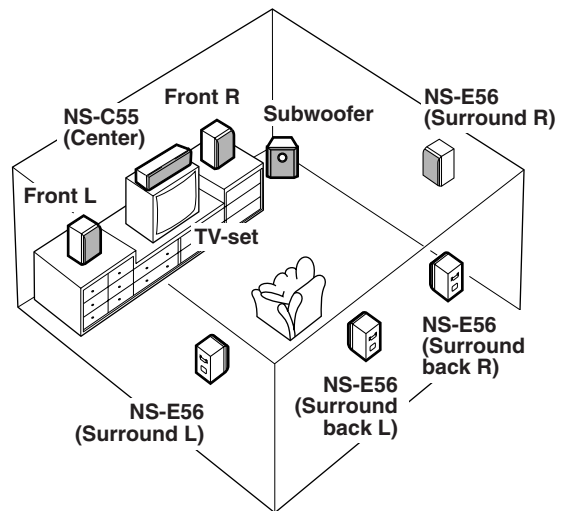

Note

These speakers feature a magnetically shielded design, but there is still a chance that placing them too close to a TV set might impair picture color. Should this happen, move the speakers away from the TV set.

■ Placing the center speaker

Place the speaker on the TV whose top is flat or on the floor under the TV or inside the TV rack so that it is stabilized. When placing the speaker on top of the TV, to prevent the speaker from falling down, put the provided fasteners at two points on both bottom of the speaker and top of the TV.

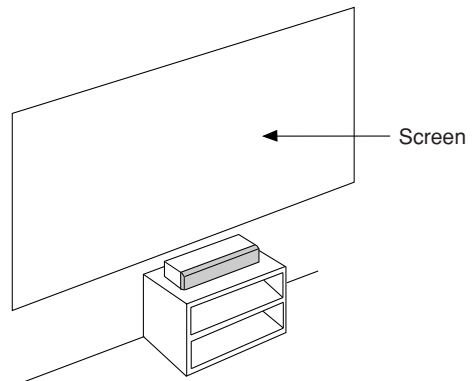
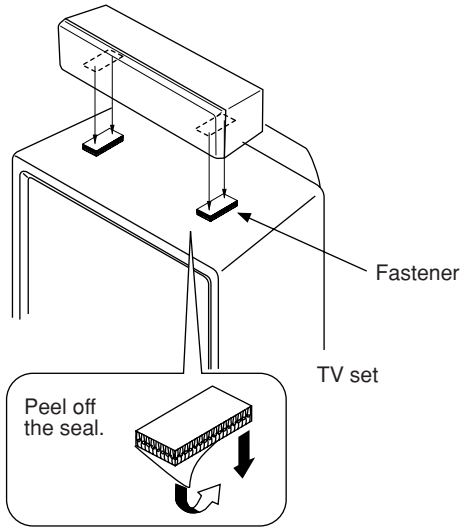

Notes

- Do not place the speaker on top of the TV whose area is smaller than the bottom area of the speaker. If placed, the speaker may drop out causing an injury to you.
- Do not place the speaker on top of the TV with an inclination.
- Do not touch the adhesive surface after peeling off the seal as this will weaken its adhesive strength.
- Thoroughly wipe clean the surface where the fastener is to be applied. Note that adhesive strength is weakened if the surface is dirty, oily or wet and that this may cause the center speaker to drop.

■ Mounting the surround and surround back speakers on the wall

The speakers can be mounted on a wall by using the bracket attached to the back panel of each speaker.

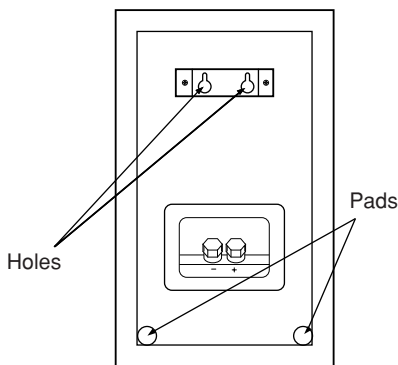

Make sure that the screws are caught by a narrow part of the holes securely.

Put the screws into a wall according to the figure shown below.

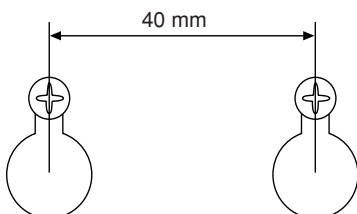

Fasten screws into a firm wall or wall support as shown in the figure below, and hang the holes on the protruding screws.

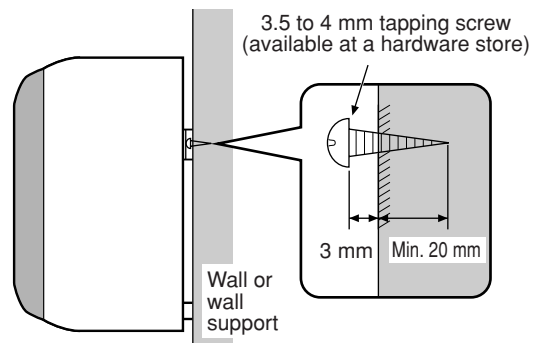

WARNING

- Each speaker weighs 2.3 kg (5 lbs. 2 oz.). Do not mount them on thin plywood or soft wall surface material, as the screws may come out of the flimsy surface, causing the speakers to fall down and be damaged, or result in personal injury.
- Do not fasten the speakers to wall with nails, adhesives, or other unsound hardware. Long term use and vibrations may cause them to fall down.
- To avoid accidents resulting from tripping over loose speaker cords, fix them to the wall.

CONNECTIONS

■ An example of basic connections

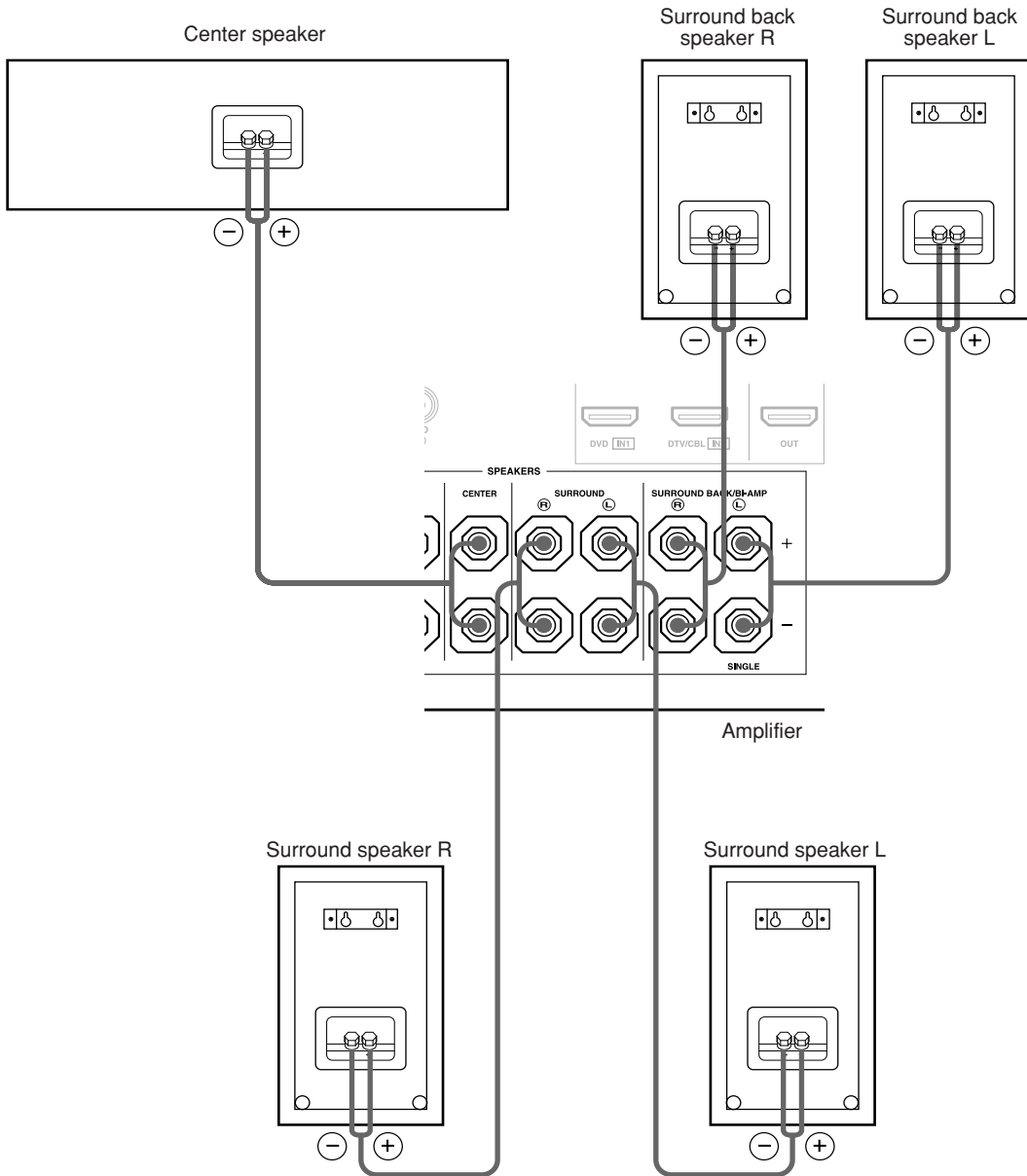

■ Connecting speaker cables

BEFORE MAKING CONNECTIONS, MAKE SURE THAT THE AMPLIFIER IS SWITCHED OFF.

■ CONNECTIONS

- Connect the screw-type input terminals at the rear of the speakers to the speaker output terminals of the amplifier (or receiver) with the provided speaker cables.
- One side of the speaker cable is red and the other side is black. Connect the (+) terminals on the amplifier (or receiver) and speakers using the red side. Connect the (-) terminals on both components using the black side of the cable.
- Connect each speaker making sure not to reverse the polarity (+, -). If the speaker is connected with reversed polarity, the sound will be unnatural and lack bass.
- Be sure to connect the left channel (L) and right channel (R) properly.

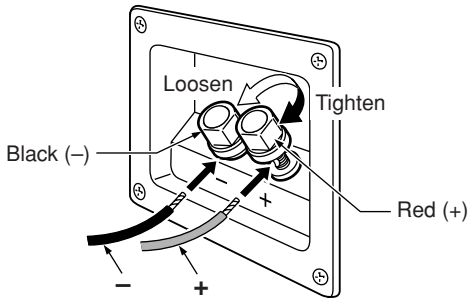

Red: positive (+)
Black: negative (-)

How to connect:

- ① Loosen the knob.
- ② Remove the insulation coating at the extremity of each speaker cable by twisting the coating off.
- ③ Insert the bare wire.

Good



No good



- ④ Tighten the knob and secure the cable.
Test the firmness of the connection by pulling lightly on the cable at the terminal.

Note

Do not let the bare speaker wires touch each other as this could damage the speaker or the amplifier, or both of them.

SPECIFICATIONS

■ NS-E56

Type 2-way acoustic-suspension speaker system
Magnetic shielding type

Driver 10 cm (4") cone woofer
2.2 cm (3/4") dome tweeter

Impedance 6 Ω

Frequency Response 80 Hz to 30 kHz

Nominal Input Power 50 W

Maximum Input Power 150 W

Sensitivity 90 dB/2.83 V/m

Crossover Frequency 5 kHz

Dimensions (W×H×D) 150×265×156.3 mm
(5-7/8"×10-3/8"×6-3/16")

Weight 2.3 kg (5 lbs. 2 oz.)×4

■ NS-C55

Type 2-way acoustic-suspension speaker system
Magnetic shielding type

Driver 10 cm (4") cone woofer×2
2.2 cm (3/4") dome tweeter

Impedance 6 Ω

Frequency Response 70 Hz to 30 kHz

Nominal Input Power 60 W

Maximum Input Power 180 W

Sensitivity 91 dB/2.83 V/m

Crossover Frequency 5 kHz

Dimensions (W×H×D) 465×135×173.5 mm
(18-5/16"×5-5/16"×6-13/16")

Weight 3.5 kg (7 lbs. 11 oz.)

* Specifications are subject to change without notice due to product improvements.



© 2008 YAMAHA CORPORATION. All rights reserved.

YAMAHA ELECTRONICS CORPORATION, USA 6660 ORANGETHORPE AVE., BUENA PARK, CALIF. 90620, U.S.A.
YAMAHA CANADA MUSIC LTD. 135 MILNER AVE., SCARBOROUGH, ONTARIO M1S 3R1, CANADA
YAMAHA ELECTRONIK EUROPA G.m.b.H. SIEMENSSTR. 22-34, 25462 RELLINGEN BEI HAMBURG, GERMANY
YAMAHA ELECTRONIQUE FRANCE S.A. RUE AMBROISE CROIZAT BP70 CROISSY-BEAUBOURG 77312 MARNE-LA-VALLEE CEDEX02, FRANCE
YAMAHA ELECTRONICS (UK) LTD. YAMAHA HOUSE, 200 RICKMANSWORTH ROAD WATFORD, HERTS WD18 7GQ, ENGLAND
YAMAHA SCANDINAVIA A.B. J A WETTERGRENS GATA 1, BOX 30053, 400 43 VÄSTRA FRÖLUNDA, SWEDEN
YAMAHA MUSIC AUSTRALIA PTY. LTD. LEVEL 1, 99 QUEENSBRIDGE STREET, SOUTHBANK, VIC 3006, AUSTRALIA

YAMAHA CORPORATION
Printed in Indonesia © WN66980