



ペダルティンパニ / PEDAL TIMPANI / PEDALPAUKE /
TIMBALES / TIMBAL DE PEDAL / TÍMPANO COM PEDAL /
ЛИТАВРА ПЕДАЛЬНАЯ / 踏板式定音鼓 / 페달 팀파니

TP-8300R series / TP-7300R series
TP-6300R series / TP-4300R series

取扱説明書

Owner's Manual

Bedienungsanleitung

Mode d'emploi

Manual de instrucciones

Manual do Proprietário

Руководство пользователя

用户手册

사용설명서

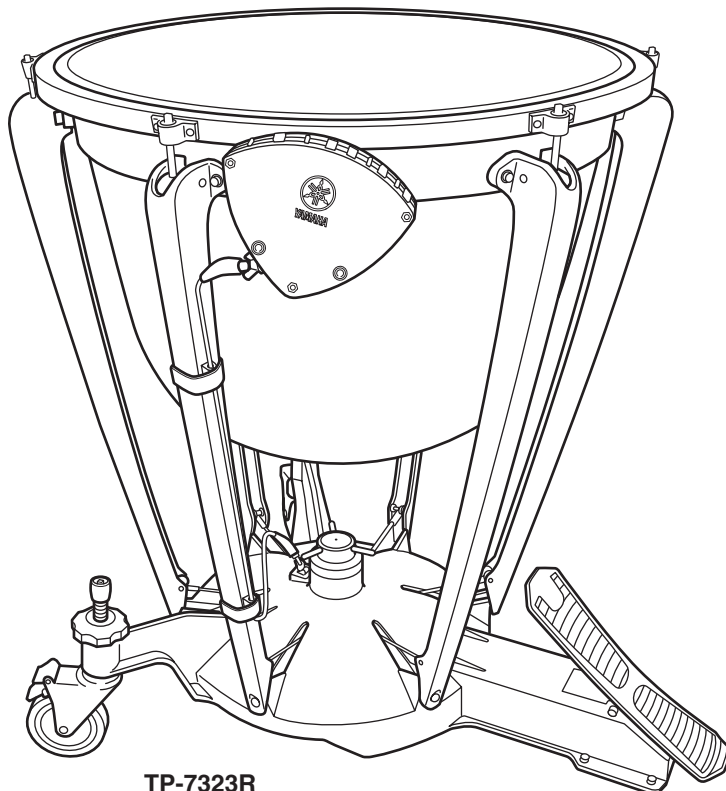

日本語

English

Deutsch

Français

Español

Português

Русский

中文

한국어

PEDAL TIMPANI

TP-8300R series / TP-7300R series
TP-6300R series / TP-4300R series

Owner's Manual

English

Thank you for purchasing Yamaha Timpani.

Please keep this manual in a safe and convenient place for future reference.

Before using your timpani for the first time be sure to carefully read the instructions on “Initial Preparation” pages 18 and 19.

Contents

PRECAUTIONS.....	14
Daily Maintenance	15
Nomenclature & Lubrication.....	16
Setting Up the Timpani.....	17
Initial Preparation	18
Adjusting the Pitch	20
Tuning Indicator Adjustment	22
Pedal Adjustment.....	23
Replacing the Head	24

PRECAUTIONS

PLEASE READ CAREFULLY BEFORE PROCEEDING

Please keep this manual in a safe and convenient place for future reference.

WARNING

Always follow the basic precautions listed below to avoid the possibility of serious injury or even death from damages or other hazards. These precautions include, but are not limited to, the following:

Handling caution

- Never lean on or climb on the instrument. It may overturn resulting in damage or injury.
- Be careful around the instrument. Bumping into it may result in injury or cause it to overturn. Keep small children away from the instrument.
- Never place your fingers or feet into the spaces underneath the pedal, the base portion of the instrument, or between moving parts such as the casters. Serious injury can result if fingers or feet become pinched.

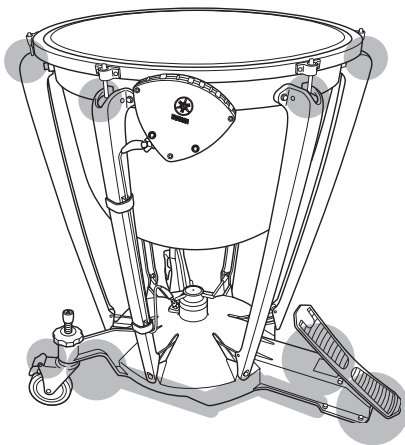

Transporting/Setup

- Never place the timpani on unstable surfaces such as an unstable riser or sloped surface. The timpani may tip over or fall resulting in damage or injury.
- When rolling the timpani on its casters, grip it by its frame and move it only on smooth, flat surfaces.
 1. Do not move on sloping, rough, or gravel surfaces.
 2. Do not run with the timpani. It may be difficult to stop the instrument which can cause injury or damage.
- If the timpani must be carried, do so with two or more people, make sure to grip the timpani by its frame.

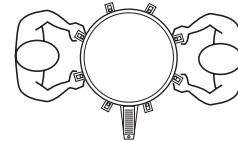

- Except for when moving the instrument, always engage the brakes on both main casters and the auxiliary brake on the pedal caster. Not engaging the brakes can result in the instrument falling over or moving resulting in injury.

Main caster

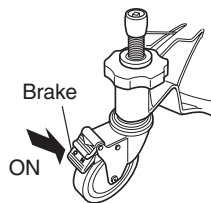

Pedal caster

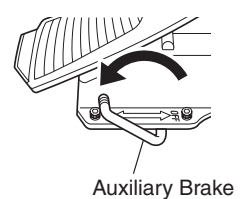

- Stop using the instrument immediately if you notice any abnormality in the pedal caster auxiliary brake. The instrument can move or fall over causing injury.
- The pedal caster and main casters are consumable parts. If you notice any abnormalities stop using the instrument and replace the casters with new ones. The instrument can move or fall over causing injury.

CAUTION

Always follow the basic precautions listed below to avoid the possibility of physical injury to you or others, or damage to the instrument or other property. These precautions include, but are not limited to, the following:

Handling caution

- When operating the pedal, do not touch the hoop, head, tuning indicator, or tension rods. Fingers may become caught or pinched resulting in injury.

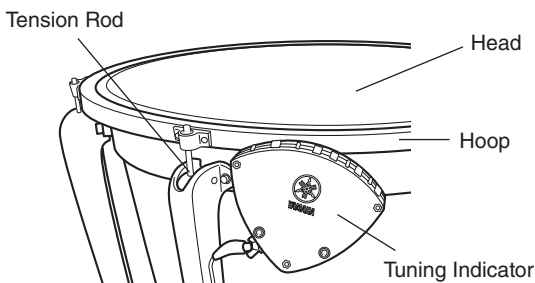

- Replace torn heads as soon as possible. The torn edge of the head is sharp and can cut hands or fingers.
- Do not put your hands inside any of the parts of the timpani (inside the tuning indicator, base, frame, etc.)
- Do not use the mallet for anything besides playing the instrument. Do not allow children to strike others with the mallet as it can cause injury or become damaged.
- The instrument may move forward slightly when engaging the pedal caster auxiliary brake. Please take note of the main caster floor positions.
- Do not tune the instrument to a pitch outside of its available range. Doing so can damage the instrument.
- Do not loosen the spring adjustment bolt more than three rotations when adjusting pedal balance. The toe end of the pedal may suddenly drop.

Yamaha cannot be held responsible for damage caused by improper use or modifications to the instrument.

Daily Maintenance

- After you have finished playing, fully lower the heel side of the pedal tuning the timpani to its lowest note. If the instrument is not to be used for an extended period, slightly loosen the head as well to extend the life of the head.
- Always place the cover on the instrument when storing to protect it from dust. Use a soft cloth to clean the head and use the head protector to protect the head from impacts, etc. Regularly wipe the entire instrument with a cloth to keep the instrument in good condition.
- The bowl has the most influence on the instrument's pitch, so never dent or strike it.
- Never hold on to anything other than the frame when moving the instrument. Doing so will cause the instrument to go out of tune and distort the shape of the hoop.
- Instruments shifting and bumping into each while transporting the timpani by truck can cause the head or hoop position to shift. To reduce the chance of position shifting, press the toe end of the pedal to increase tension on the head.

Please use Yamaha care products for daily maintenance.

Nomenclature & Lubrication

■ Nomenclature

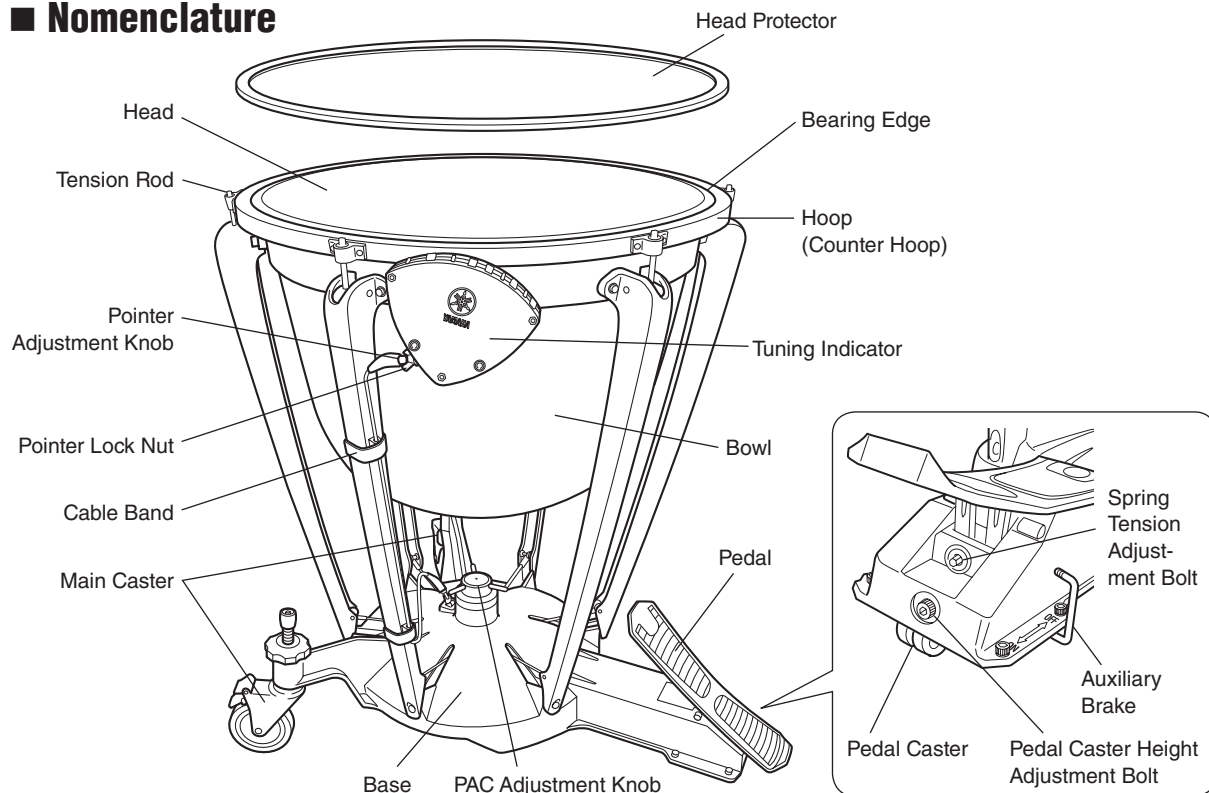

* The TP-7300R series is used for all illustrations in this manual.

Supplied Accessories

- Timpani Tuning Key 1
- Allen Wrench 1
- Note Name Marker 1

! Caution

Never place your fingers or feet into the spaces underneath the pedal, the base portion of the instrument, or between moving parts such as the casters. Serious injury can result if fingers or feet become pinched.

■ Lubrication

Lubricate the moving parts indicated in the diagram. This should be done at least once a year, or as needed.

- * **Spray type lubricant is recommended.**
- * **Do not touch the lubricated parts.**
- * **Please use Yamaha care products for daily maintenance.**

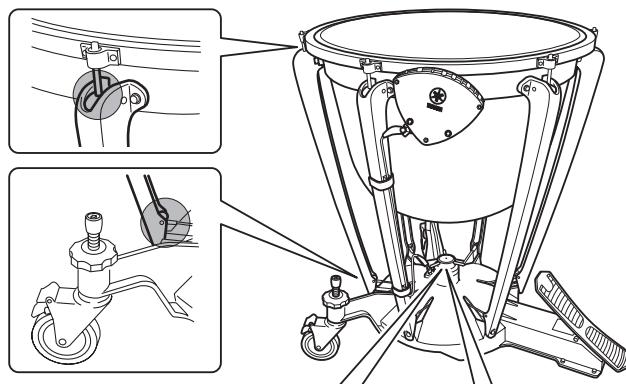

TP-8300R/7300R series



TP-6300R/4300R series



Setting Up the Timpani

■ Using the Casters

The instrument is equipped with three casters.

- ① Main caster x2
- ② Pedal caster x1

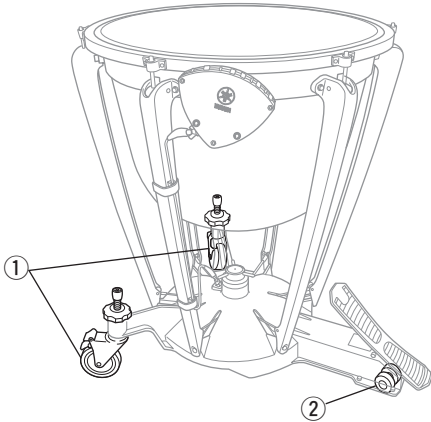

Caution

Except for when moving the instrument, always engage the brakes on both main casters and the auxiliary brake on the pedal caster.

Main caster

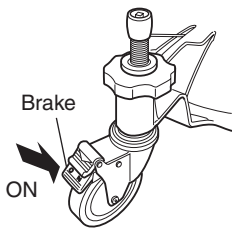

Pedal caster

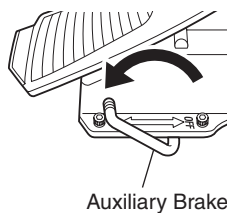

Playing the instrument without the main and auxiliary brakes engaged can result in the instrument moving about during the performance. It can also be a source of noise. Adjusting the pedal, tuning, and adjusting the PAC system can also be very dangerous if done without the brakes engaged. The instrument unexpectedly moving or falling over can lead to injury.

Stop using the instrument immediately if you notice any abnormality in the auxiliary brake. Also, release the main and auxiliary brakes before moving the instrument.

■ Adjusting the Playing Angle

All three casters offer independent height adjustment letting you adjust the height and angle of the playing surface.

[Main Caster]

- 1 Release the main caster brakes.
- 2 Turn the lock nut counter-clockwise (left) to release the lock nut on the top of the caster.
- 3 Turn the caster axle cap using a timpani tuning key to adjust the height.
Turn counter-clockwise (left) to lower and clockwise (right) to raise the height.
- 4 Turn the lock nut clockwise (right) to lock.

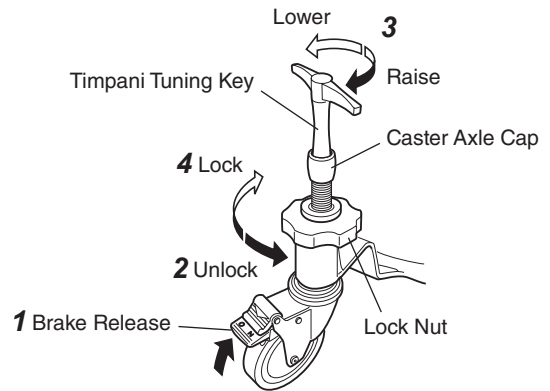

[Pedal Caster]

Using the supplied Allen wrench, turn the pedal caster height adjustment bolt clockwise (right) to raise the pedal, increasing its distance from the floor, or counter-clockwise (left) to lower its height.

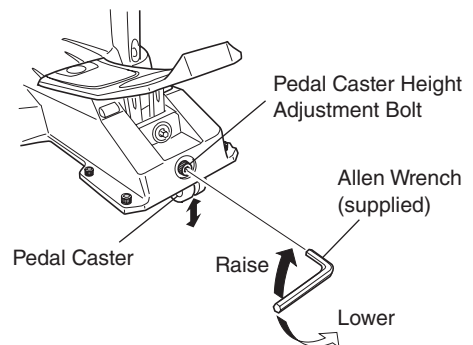

Initial Preparation

Your Yamaha timpani are equipped with a plastic head carefully mounted and adjusted at the factory. However, new heads tend to stretch during shipping and storage, so it may be necessary to re-tune the instrument before using. Before playing the pedal timpani for the first time after purchase, please follow the procedure below and make sure that the head is properly adjusted.

- 1 The area between the bearing edge and the inner circle of the counter hoop is called the collar. Please make sure that the width of this collar is uniform, as shown in the illustration titled "Correct".

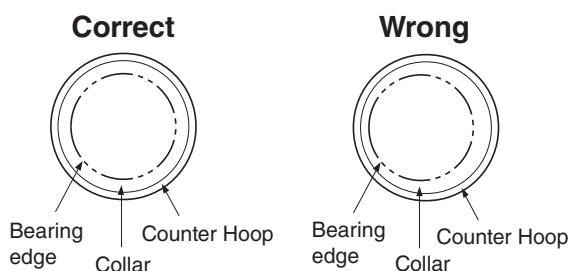

If collar width is not uniform, fully depress the heel end of the pedal. While holding the pedal in this position, realign the head and hoop as shown in the "Correct" illustration.

- 2 Fully depress the heel end of the pedal. While holding the pedal in this position, use the supplied timpani tuning key to tighten the tension rods one by one $\frac{1}{4}$ of a turn (90°) in the order shown in the illustration below.

It is very important that all tension rods be turned the same amount.

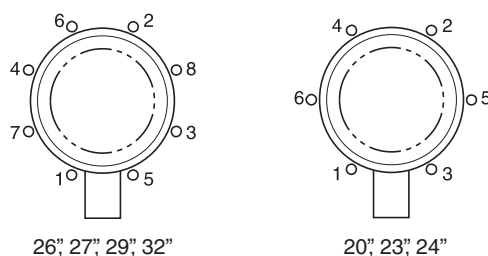
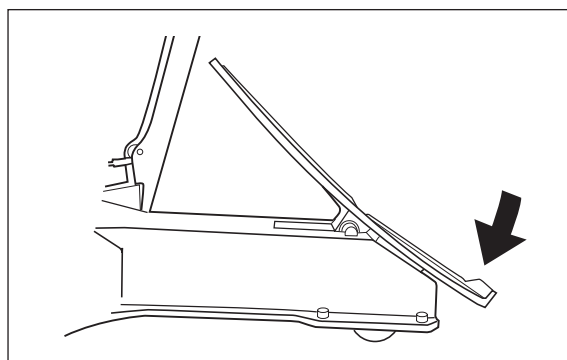

Caution

Never place your fingers or feet into the spaces underneath the pedal, the base portion of the instrument, or between moving parts such as the casters. Serious injury can result if fingers or feet become pinched.

Attaching the Key/Wrench Holder

The attachment plate located on the side of the timpani opposite of the tuning indicator is for attaching the key/wrench holder, which holds the timpani tuning key and hex wrench. When relocating the key/wrench holder to the opposite side of the timpani, remove the four bolts using the supplied hex wrench, then attach using the bolts as shown in the figure on the right.

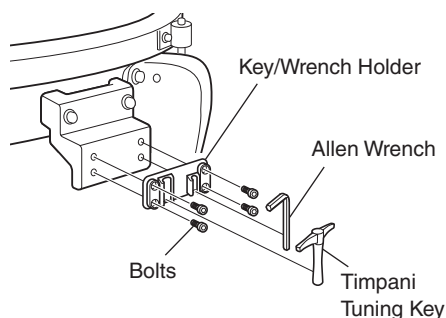

3 Take your foot off the pedal.

- **Heel still moves up**
→ Repeat steps **2** through **3**.
- **Heel stays down**
→ Go to step **4**.

4 Put your foot on the pedal and fully depress it in either direction (toe and heel).

- **Toe and heel feel equal**
→ Go to step **5**.
- **Heel feels lighter than toe (*)**
→ Head is too tight and should be loosened. Keeping the heel of the pedal depressed, loosen the first tension rod by 1/2 turn and then re-tighten it by 1/4 of a turn. Perform this operation for all other tension rods in the order shown in step **2**. Repeat this procedure until proper head tension is obtained then go to step **5**.

- **Heel feels heavier than toe**
→ Head is not tight enough. Keeping the heel end of the pedal depressed, tighten each of the tension rods another 1/8 (45°) turn in the same order as in step **3**. Repeat this procedure until proper head tension is obtained then go to step **5**.

5 Move the pedal into an intermediate position, as shown below, and remove your foot from the pedal. Confirm that the pedal stays in this position and does not move.

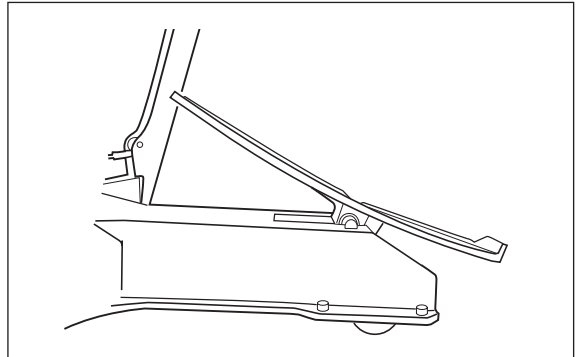

- **If the pedal remains in the same position adjustment is complete. Go to step 6.**
- **If the toe of the pedal moves downward**
→ The head is too tight. Loosen the head using the procedure described in step **4 (*)**.

6 Tap the head lightly with the mallet. The standard striking point is shown below.

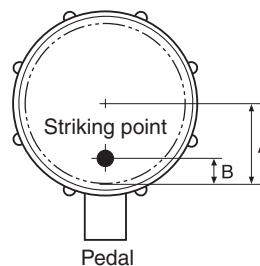

The standard striking point lies at distance B from the bearing edge, which corresponds approximately to 1/4 to 1/3 of the distance between the bearing edge and the center of the head.

As the toe of the pedal is pressed down, the pitch is raised.

For details on precise tuning refer to “**Adjusting the Pitch**” on the following page.

As the head will stretch over time, readjustment should be performed periodically (starting with step 4).

Adjusting the Pitch

Before playing the pedal timpani for the first time after purchase, make sure you properly adjust the head following the procedure in the “Initial Preparation” section on pages 18-19.

■ Head Tuning

1 Tuning is adjusted on the lowest note of the timpani. For this reason, the heel of the pedal must stay fully lowered during the tuning procedure. The pitch of the lowest note (and the tonal range) depends on the size of your timpani. For example, as shown in the chart below, the lowest sound of a 29" timpani should be tuned to F. When tuned properly, your Yamaha timpani will play throughout its full tonal range with balanced tension in the pedal.

● Usable Tonal Ranges for Yamaha Timpani

32" (81cm) 29" (74cm) 27" (69cm) 26" (66cm) 24" (61cm) 23" (58cm) 20" (51cm)

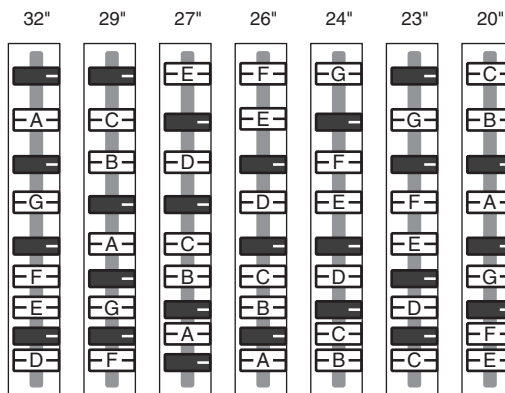

Note

Do not tune the timpani to a pitch outside of its usable range. Doing so can damage the instrument.

Keep the heel of the pedal fully lowered during the tuning procedure (steps 2 through 7 below) if not specified otherwise.

2 Strike the head and check the sound.
The standard striking point is shown below.

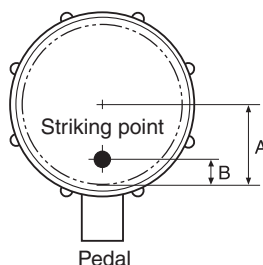

The standard striking point lies at distance B from the bearing edge, which corresponds approximately to 1/4 to 1/3 of the distance between the bearing edge and the center of the head.

• **Sound is lower than the tuning note**

→ Go to step 3.

• **Sound is higher than the tuning note**

→ Loosen the tension rods by an equal amount in the order shown in the figure of step 2 on page 18.

When loosening the tension rods, always loosen them by twice the desired amount, and then return (re-tighten) them by half. When the sound lies within 1 semitone below the desired pitch after loosening the tension rods (repeatedly, if necessary), proceed with step 3.

3 Lightly strike the head with the mallet about 2 inches (5 cm) from the bearing edge at each tension rod. Check which tension rod has the highest sound.

- **Pitch of the highest sound is higher than the tuning note (*)**

→ Loosen the corresponding tension rod by about 1/16 to 1/8 of a turn. First loosen the bolt by twice the desired amount, and then return (re-tighten) it by half. After loosening the tension rod, repeat from the beginning of step **3**.

- **Pitch of the highest sound is lower than the tuning note**

→ Go to step **4**.

4 Tighten the other bolts little by little (by about 1/16 to 1/8 of a turn) until the sounds at the corresponding striking points match the pitch of the highest sound. Please note that tightening one bolt also raises the pitch of the neighboring and opposite tension rods. Thus, after tightening the tension rod with the lowest sound, again check the pitch at the other tension rods before tightening the tension rod with the next lowest pitch. While alternately tightening the other bolts, do not touch the tension rod with the highest pitch (reference pitch).

5 Loosen all over-tightened bolts according to the procedure described in step **3 (*)**. When the pitch is approximately the same at each bolt, repeatedly depress the toe and heel of the pedal several times.

6 Repeat steps **3** through **5** until the pitch at each bolt is exactly the same.

7 Check the sound by striking the head as described in step **2**.

- **Sound is lower than the tuning note**

→ Tune the instrument by tightening all tension rods by an equal amount (max. 1/16 of a turn).

- **Sound is higher than the tuning note**

→ Tune the instrument by loosening all tension rods by an equal amount (max. 1/16 of a turn) according to the procedure described in step **3 (*)**.

8 Operate the pedal as described in step **5**. If the pitch does not change, the instrument is tuned properly.

(If the pitch changes, repeat from step **7**.)

The instrument is now tuned to the lowest note of its tonal range. Depress the toe of the pedal to change to a higher note.

9 After tuning, perform “**Tuning Indicator Adjustment**” and then “**Pedal Adjustment**”.

Tuning Indicator Adjustment

The tuning indicator shows where to set the pedal for each note. After tuning the instrument, you must set each note on the indicator to its proper position.

1 After you have tuned your timpani to the lowest note of its tonal range, make sure that the pointer is located within 1/16" – 1/8" from the pedal-side end of the indicator rail.

* If not, refer to "Adjusting the Pointer Position".

2 Slide the lowest note name marker on the indicator ("C" in the case of a 23" timpano*) to the position where its center line coincides with the pointer.

* "Usable Tonal Ranges for Yamaha Timpani" on page 20.

3 Tune the instrument to the next highest pitch (note) by moving the pedal, and then slide the corresponding note name marker on the rail to the respective pointer position. Repeat for each remaining note.

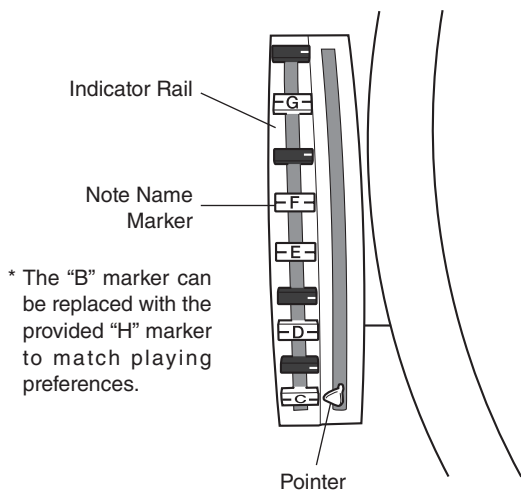

■ Adjusting the Pointer Position

First loosen the pointer lock nut and then turn the adjuster as follows:

- **Pointer is located beyond the lower rail end when the heel of the pedal is lowered fully (lowest note).**

→ Turn the adjuster to the left (counter clockwise) until the pointer is aligned with the lowest note of the indicator.

- **Pointer moves beyond the upper rail end before the toe of the pedal reaches the end of its stroke, or pointer does not reach the lower rail end when the heel of the pedal is lowered fully (lowest sound).**

→ Turn the adjuster to the right (clockwise) to correct the pointer position as required.

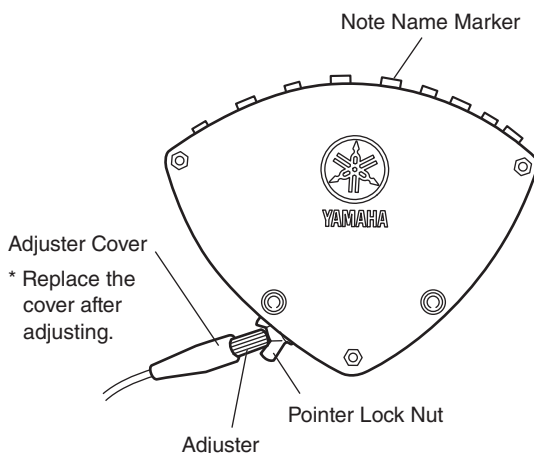

Relocating the Tuning Indicator

The timpani is shipped with a universal style tuning indicator already attached however, the tuning indicator can be relocated for German style tuning. Using the supplied hex wrench, remove the two bolts holding the tuning indicator in place as shown in the diagram (right), then slide the bolts through the holes on the tuning indicator from the opposite side. In either position, make sure that the note indicator bridge is easily viewable.

Universal Style Attachment

German Style Attachment

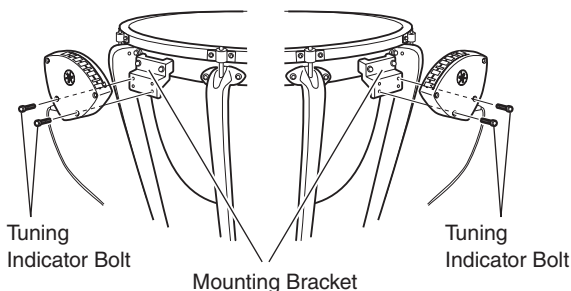

Pedal Adjustment

Make sure the timpani is properly tuned before making adjustment to the spring or PAC.

■ Pedal Balance Adjustment

After depressing the toe and heel of the pedal, turn the spring tension adjustment bolt as described below.

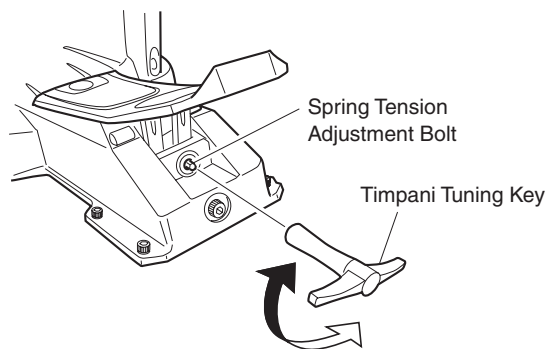

- **Heel moves up when releasing the foot from the pedal after depressing the heel, or the heel feels heavier than the toe.**

→ Turn the spring tension adjustment bolt to the left (counterclockwise).

- **Toe moves up when releasing the foot from the pedal after depressing the toe, or the toe feels heavier than the heel.**

→ Turn the spring tension adjustment bolt to the right (clockwise).

Use the supplied timpani tuning key to turn the spring tension adjustment bolt. Do not turn too many full rotations at once, and re-check the adjustment every 2 turns by pressing the toe and heel of the pedal.

⚠ **Caution**

Never place your fingers or feet into the spaces underneath the pedal, the base portion of the instrument, or between moving parts such as the casters. Serious injury can result if fingers or feet become pinched.

⚠ **Note**

Do not loosen the spring tension adjustment bolt by more than 3 rotations at a time, as the toe of the pedal tends to drop abruptly after a specific point.

■ Pedal Adjustment Clutch (TP-8300R/7300R series only)

The pedal mechanism of this instrument is equipped with the PAC (Pedal Adjustment Clutch) system. This Yamaha original mechanism lets you adjust pedal torque (pedal weight) while maintaining pedal balance.

[PAC Adjustment]

- 1 Turn the lock nut located below the PAC adjustment knob counter-clockwise (left) to release the lock.

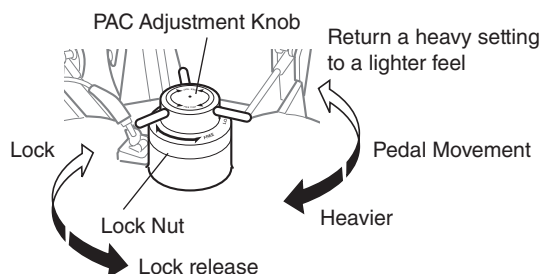

- 2 To give the pedal a heavier feel turn the PAC adjustment knob clockwise. To return a heavy setting to a lighter feel, turn the PAC adjustment knob counter-clockwise.

* **Please make adjustments with one hand. Never attempt turning the adjuster with both hands or with tools (doing so will damage the PAC system).**

- 3 After completing adjustment, engage the lock by turning the lock nut clockwise.

■ PAC Handling Precautions ■

- Even with the PAC system adjusted to its heaviest setting, the pedal is not “locked” in place so do not use a heavy setting to prevent the pedal from jumping when removing the head.
- There is a limit to how far the PAC adjustment knob can be turned clockwise. Do not force the knob if it becomes difficult to turn. Doing so may damage the mechanism.

Replacing the Head

- 1** To prevent the pedal from suddenly dropping due to spring tension, hold the heel end of the pedal all the way down and place a block of wood between the pedal and the base.

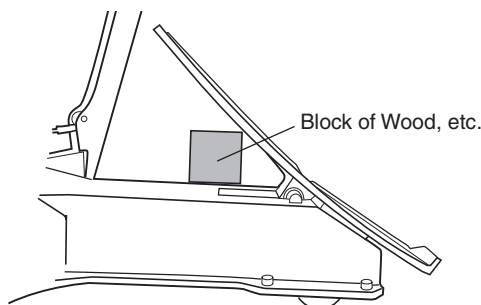

Caution

Never touch the pedal assembly when loosening the tension rods (when loosening the head). Also, never place your fingers or feet in the space under the pedal, around the base, or the moving parts. Spring tension may cause the pedal to suddenly move posing a great danger.

- 2** Loosen the tension rods on opposite sides of the timpani and remove the head. We recommend that you mark the pedal side of the hoop with a piece of tape, etc. so that the hoop can be reattached to the same position.

* **Avoid touching the tension rod threads, as they are greased.**

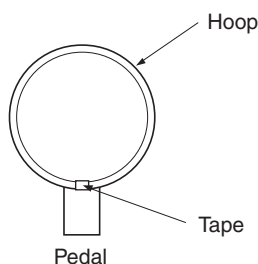

- 3** Remove the hoop and head together.

* **Do not let the hoop come in contact with the bearing edge, etc.**

- 4** Edge tape is applied to the bearing edge. The tape provides a smooth edge, which is very important to the operation of the timpani. To prevent damage to the tape, please remove any dust or dirt.

* **If the tape is peeling or badly damaged, it must be replaced with "Timpani Teflon Tape".**

- 5** Place the new head with the hoop on the bowl. When using a Yamaha timpani head, make sure its YAMAHA logo is on the side opposite the pedal.

The hoop must be re-mounted in the same position as marked with a piece of tape in step 2. In the proper order, tighten the tension rods alternately by hand until the head is tensioned slightly. At this time, make sure that the head and hoop are centered on the bowl.

Tighten each tension rod an additional 1/4 of a turn using the timpani key. Repeat at least 4 times.

- 6** Adjust the timpani as described on page 18 "Initial Preparation" starting with step 2. For precise tuning, refer to the section "Adjusting the Pitch" on page 20.

Interval for head replacement

When the head is slightly tensioned and its surface looks wavy or shows dents, it is time to replace the head with a new one.

The maximum head life normally is approximately 2 years and depends on the frequency and duration of use. However, the head should always be replaced before the sound quality deteriorates dramatically. If a head is left on and used more than two years, the following problems may occur:

- **It may become difficult to tune the head to the proper pitch range.**
- **It may become difficult to balance the pedal.**
- **The main unit mechanisms themselves may become damaged.**

Yamaha recommends replacing the head every year.



ヤマハ株式会社

〒 430-8650 静岡県浜松市中区中沢町 10-1