



RX-V365

AV Receiver

OWNER'S MANUAL

Caution: Read this before operating your unit.

- 1 To assure the finest performance, please read this manual carefully. Keep it in a safe place for future reference.
- 2 Install this sound system in a well ventilated, cool, dry, clean place – away from direct sunlight, heat sources, vibration, dust, moisture, and/or cold. Allow ventilation space of at least 30 cm on the top, 20 cm on the left and right, and 20 cm on the back of this unit.
- 3 Locate this unit away from other electrical appliances, motors, or transformers to avoid humming sounds.
- 4 Do not expose this unit to sudden temperature changes from cold to hot, and do not locate this unit in an environment with high humidity (i.e. a room with a humidifier) to prevent condensation inside this unit, which may cause an electrical shock, fire, damage to this unit, and/or personal injury.
- 5 Avoid installing this unit where foreign objects may fall onto this unit and/or this unit may be exposed to liquid dripping or splashing. On the top of this unit, do not place:
 - Other components, as they may cause damage and/or discoloration on the surface of this unit.
 - Burning objects (i.e. candles), as they may cause fire, damage to this unit, and/or personal injury.
 - Containers with liquid in them, as they may fall and liquid may cause electrical shock to the user and/or damage to this unit.
- 6 Do not cover this unit with a newspaper, tablecloth, curtain, etc. in order not to obstruct heat radiation. If the temperature inside this unit rises, it may cause fire, damage to this unit, and/or personal injury.
- 7 Do not plug in this unit to a wall outlet until all connections are complete.
- 8 Do not operate this unit upside-down. It may overheat, possibly causing damage.
- 9 Do not use force on switches, knobs and/or cords.
- 10 When disconnecting the power cable from the wall outlet, grasp the plug; do not pull the cable.
- 11 Do not clean this unit with chemical solvents; this might damage the finish. Use a clean, dry cloth.
- 12 Only voltage specified on this unit must be used. Using this unit with a higher voltage than specified is dangerous and may cause fire, damage to this unit, and/or personal injury. Yamaha will not be held responsible for any damage resulting from use of this unit with a voltage other than specified.
- 13 To prevent damage by lightning, keep the power cord and outdoor antennas disconnected from a wall outlet or the unit during a lightning storm.
- 14 Do not attempt to modify or fix this unit. Contact qualified Yamaha service personnel when any service is needed. The cabinet should never be opened for any reasons.
- 15 When not planning to use this unit for long periods of time (i.e. vacation), disconnect the AC power plug from the wall outlet.
- 16 Install this unit near the AC outlet and where the AC power plug can be reached easily.
- 17 Be sure to read the “Troubleshooting” section on common operating errors before concluding that this unit is faulty.
- 18 Before moving this unit, press **(A) STANDBY/ON** to set this unit in the standby mode, and disconnect the AC power plug from the wall outlet.
- 19 **VOLTAGE SELECTOR** (Asia and General models only)
The **VOLTAGE SELECTOR** on the rear panel of this unit must be set for your local main voltage **BEFORE** plugging into the AC wall outlet. Voltages are:
..... AC 110–120/220–240 V, 50/60 Hz
- 20 The batteries shall not be exposed to excessive heat such as sunshine, fire or like.
- 21 Excessive sound pressure from earphones and headphones can cause hearing loss.
- 22 When replacing the batteries, be sure to use batteries of the same type. Danger of explosion may happen if batteries are incorrectly replaced.

WARNING

TO REDUCE THE RISK OF FIRE OR ELECTRIC SHOCK, DO NOT EXPOSE THIS UNIT TO RAIN OR MOISTURE.

As long as this unit is connected to the AC wall outlet, it is not disconnected from the AC power source even if you turn off this unit by **(A) STANDBY/ON**. In this state, this unit is designed to consume a very small quantity of power.

Contents

INTRODUCTION

| | |
|----------------------------------|---|
| Features | 2 |
| Supplied accessories | 2 |
| Functional overview | 3 |
| Front panel | 3 |
| Front panel display..... | 4 |
| Remote control..... | 5 |
| Rear panel | 6 |
| Quick start guide | 7 |

PREPARATION

| | |
|--|----|
| Preparation of remote control | 8 |
| Connections | 9 |
| Placing speakers..... | 9 |
| Connecting speakers | 9 |
| Connecting video components..... | 11 |
| Connecting other components | 13 |
| Using the VIDEO AUX jacks on the front panel | 14 |
| Connecting the FM and AM antennas | 15 |
| Connecting the power cable..... | 15 |
| Turning on and off the power | 15 |
| Optimizing the speaker setting for your listening room (YPAO) | 16 |
| Using AUTO SETUP..... | 16 |

BASIC OPERATION

| | |
|---|----|
| Playback | 18 |
| Basic procedure..... | 18 |
| Additional operations..... | 19 |
| Selecting the SCENE templates | 22 |
| Selecting the desired SCENE template..... | 22 |
| Creating your original SCENE templates | 24 |
| Using remote control on the SCENE feature | 25 |
| Sound field programs | 26 |
| Selecting sound field programs..... | 26 |
| FM/AM tuning | 28 |
| Overview..... | 28 |
| FM/AM tuning operations | 28 |
| Preset FM/AM stations | 28 |

ADVANCED OPERATION

| | |
|---|----|
| Set menu | 30 |
| Using set menu..... | 31 |
| 1 SOUND MENU | 31 |
| 2 INPUT MENU | 33 |
| 3 OPTION MENU | 34 |
| Remote control features | 36 |
| Controlling this unit, a TV, or other components | 36 |
| Setting remote control codes..... | 38 |
| Advanced setup | 39 |

ADDITIONAL INFORMATION

| | |
|------------------------------|----|
| Troubleshooting | 40 |
| Glossary | 45 |
| Specifications | 46 |
| Index | 47 |

APPENDIX

(at the end of this manual)

| | |
|---|---|
| List of remote control codes | i |
|---|---|

About this manual

- * indicates a tip for your operation.
- Some operations can be performed by using either the buttons on the front panel or the ones on the remote control. In case the button names differ between the front panel and the remote control, the button name on the remote control is given in parentheses.
- This manual is printed prior to production. Design and specifications are subject to change in part as a result of improvements, etc. In case of differences between the manual and product, the product has priority.
- “**ⓐ**STANDBY/ON” or “**ⓑ**DVD” (example) indicates the name of the parts on the front panel or the remote control. Refer to the “Functional overview” on page 3.

INTRODUCTION

PREPARATION

BASIC OPERATION

ADVANCED OPERATION

ADDITIONAL INFORMATION

APPENDIX

English

INTRODUCTION

Features

Built-in 5-channel power amplifier

(1 kHz, 0.9% THD, 6 Ω)

Front: 100 W/ch

Center: 100 W

Surround: 100 W/ch

Various input/output connectors

- ◆ HDMI (IN x 2, OUT x 1), Component video (IN x 3, OUT x 1), Composite video (IN x 3, OUT x 2), Coaxial digital audio (IN x 1), Optical digital audio (IN x 2), Analog audio (IN x 9, OUT x 2)
- ◆ Speaker out (5-channel), Subwoofer out
- ◆ Discrete multi-channel input (6-channel)

SCENE select function

- ◆ Preset SCENE templates for various situations
- ◆ SCENE template customizing capability

Sound field programs

- ◆ Proprietary Yamaha technology for the creation of surround field
- ◆ Compressed Music Enhancer mode
- ◆ SILENT CINEMA™

Decoders and DSP circuits

- ◆ Dolby Digital decoder
- ◆ Dolby Pro Logic/Dolby Pro Logic II decoder
- ◆ DTS decoder
- ◆ Virtual CINEMA DSP
- ◆ SILENT CINEMA™

Sophisticated FM/AM tuner

- ◆ 40-station random and direct preset tuning
- ◆ Automatic preset tuning

HDMI™ (High-Definition Multimedia Interface)

- ◆ HDMI interface for standard, enhanced or high-definition video (includes 1080p video signal transmission)

Other features

- ◆ 192-kHz/24-bit D/A converter
- ◆ Sleep timer
- ◆ Cinema and music night listening modes
- ◆ Remote control with preset remote control codes



Manufactured under license from Dolby Laboratories. "Dolby," "Pro Logic," and the double-D symbol are trademarks of Dolby Laboratories.



Manufactured under license under U.S. Patent No's: 5,451,942;5,956,674;5,974,380;5,978,762;6,487,535 and other U.S. and worldwide patents issued and pending. DTS is a registered trademark and the DTS logos and symbol are trademarks of DTS, Inc. © 1996-2007 DTS, Inc. All Rights Reserved.

HDMI

"HDMI," the "HDMI" logo and "High-Definition Multimedia Interface" are trademarks, or registered trademarks of HDMI Licensing LLC.

SILENT™
CINEMA

"SILENT CINEMA" is a trademark of Yamaha Corporation.

Supplied accessories

Check that you received all of the following parts.

- Remote control
- Batteries (2) (AAA, R03, UM-4)
- AM loop antenna
- Indoor FM antenna
- Optimizer microphone

Functional overview

Front panel

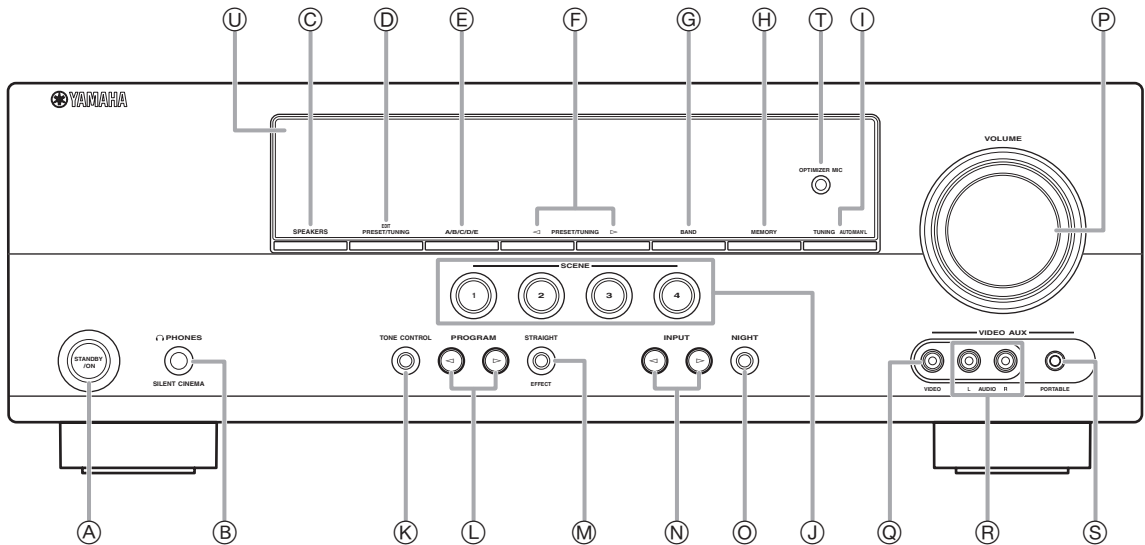

- (A) STANDBY/ON**
Turns on this unit, or sets it to standby mode (see page 15).
- (B) PHONES jack**
Connect to a pair of headphones (see page 20).
- (C) SPEAKERS**
Turns on or off the set of front speakers connected to the FRONT A or FRONT B speaker terminals (see page 19).
- (D) EDIT PRESET/TUNING**
Switches the tuning mode (see page 28).
- (E) A/B/C/D/E**
Selects the preset station group (A to E) (see page 29).
- (F) PRESET/TUNING </>**
Tunes into radio stations manually or automatically and selects a preset station group (see page 28).
- (G) BAND**
Selects the reception band from FM and AM (see page 28).
- (H) MEMORY**
Stores a station that you tuned into as a preset station (see page 28).
- (I) TUNING AUTO/MAN'L**
Selects a tuning method from automatic or manual tuning (see page 28).
- (J) SCENE 1/2/3/4**
Recalls an input source and a sound field program assigned to each SCENE button (see page 22).
- (K) TONE CONTROL**
Selects "BASS" and "TREBLE" to adjust frequency response (see page 20).
- (L) PROGRAM </>**
Selects a sound field program (see page 26).
- (M) STRAIGHT**
Activates the "STRAIGHT" mode (see page 27).
- (N) INPUT </>**
Selects an input source (see page 18).
- (O) NIGHT**
Selects a night listening mode (see page 20).
- (P) VOLUME control**
Adjusts the volume level of this unit (see page 18).
- (Q) VIDEO (VIDEO AUX) jack**
Connects to a game console or a video camera using a composite video cable (see page 14).
- (R) AUDIO L/R (VIDEO AUX) jacks**
Connects to a game console or a video camera using analog audio cables (see page 14).
- (S) PORTABLE (VIDEO AUX) jack**
Connects to an audio component (such as iPod) (see page 14).
- (T) OPTIMIZER MIC jack**
Connect to the supplied optimizer microphone (see page 16).
- (U) Front panel display**
Shows information about the operational status of this unit (see page 18).

Front panel display

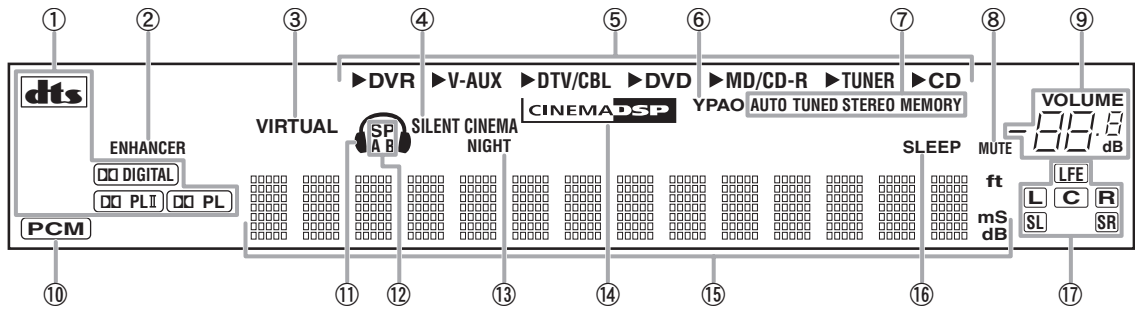

① Decoder indicator

Lights up when any of the decoders of this unit functions.

② ENHANCER indicator

Lights up when the Compressed Music Enhancer mode is selected (see page 26).

③ VIRTUAL indicator

Lights up when Virtual CINEMA DSP is active (see page 27).

④ SILENT CINEMA indicator

Lights up when headphones are connected and a sound field program is selected (see page 27).

⑤ Input source indicators

The corresponding cursor lights up to show the currently selected input source.

⑥ YPAO indicator

Lights up when you run "AUTO SETUP" and when the speaker settings set in "AUTO SETUP" are used without any modifications (see page 16).

⑦ Tuner indicators

Lights up when this unit is in the FM or AM tuning mode (see page 28).

⑧ MUTE indicator

Flashes while the MUTE function is on (see page 20).

⑨ VOLUME level indicator

Indicates the current volume level.

⑩ PCM indicator

Lights up when this unit is reproducing PCM (Pulse Code Modulation) digital audio signals.

⑪ Headphones indicator

Lights up when headphones are connected (see page 20).

⑫ SP A B indicators

Lights up according to the set of front speakers selected (see page 18).

⑬ NIGHT indicator

Lights up when you select a night listening mode (see page 20).

⑭ CINEMA DSP indicator

Lights up when you select a sound filed program (see page 27).

⑮ Multi-information display

Shows the name of the current sound field program and other information when adjusting or changing settings.

⑯ SLEEP indicator

Lights up while the sleep timer is on (see page 21).

⑰ Input channel and speaker indicators

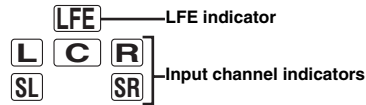

• LFE indicator

Lights up when the input signal contains the LFE signal.

• Input channel indicators

Indicates the channel components of the current digital input signal.

Remote control

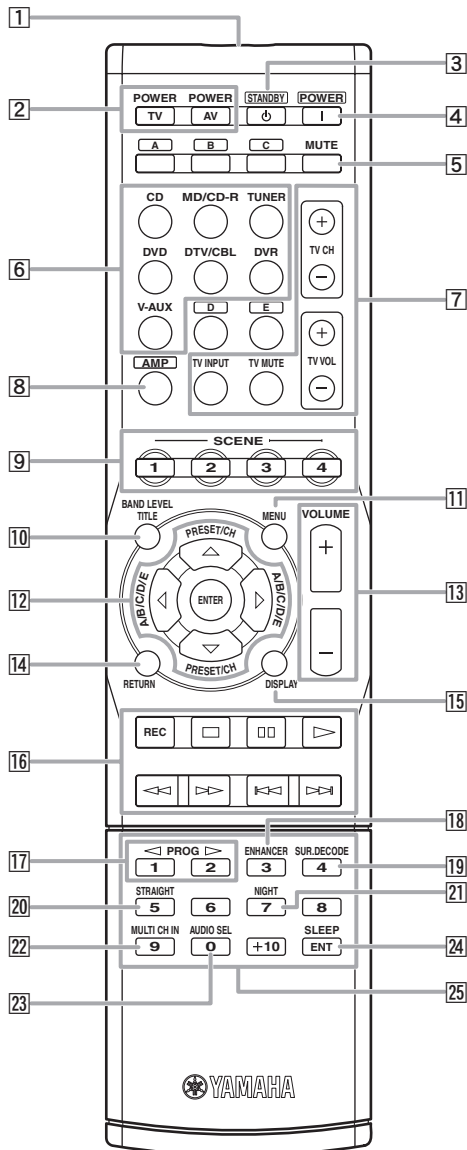
**1 Infrared window**

Outputs infrared control signals (see page 8).

2 TV/AV POWER

Turns your TV or other components on or off (see page 37).

3 STANDBY (⏻)

Sets this unit to the standby mode (see page 15).

4 POWER (⏻)

Turns this unit on (see page 15).

5 MUTE

Mutes audio output (see page 20).

6 Input selector buttons

Switches the input source to each source (see page 18).

7 TV control buttons

Controls your TV (see page 36).

8 AMP

Press this button before you control this unit (see page 18).

9 SCENE 1/2/3/4

Recalls an input source and a sound field program assigned to each SCENE button (see page 22).

10 BAND LEVEL TITLE

Selects the speaker that you want to adjust (see page 20).

11 MENU

Displays the set menu on the front panel display (see page 31).

12 Cursors (</>/⏮/⏭) / ENTER

- Press cursors to navigate the set menu (see page 31).
- Press ENTER to confirm a selection in the set menu (see page 31).

13 VOLUME +/-

Adjusts the volume level of this unit (see page 18).

14 RETURN

Returns the previous menu level when the set menu is displayed (see page 31).

15 DISPLAY

Displays the information of external components (such as a DVD player) (see page 37).

16 Control buttons

Control external components (such as a DVD player) connected to this unit (see page 37).

17 PROG </>

Selects the sound field program (see page 26).

18 ENHANCER

Sets the sound field program to the “Music Enh. 2ch” or “Music Enh. 5ch” (see page 26).

19 SUR.DECODE

Selects a decoder from four decoders (see page 27).

20 STRAIGHT

Activates the “STRAIGHT” mode (see page 27).

21 NIGHT

Selects a night listening mode (see page 20).

22 MULTI CH IN

Sets the input source to MULTI CH IN (see page 19).

23 AUDIO SEL

Selects an audio input select setting for each input source (see page 19).

24 SLEEP

Sets the sleep timer (see page 21).

25 Numeric buttons

Enter remote control codes or preset station number (see page 38).

Rear panel

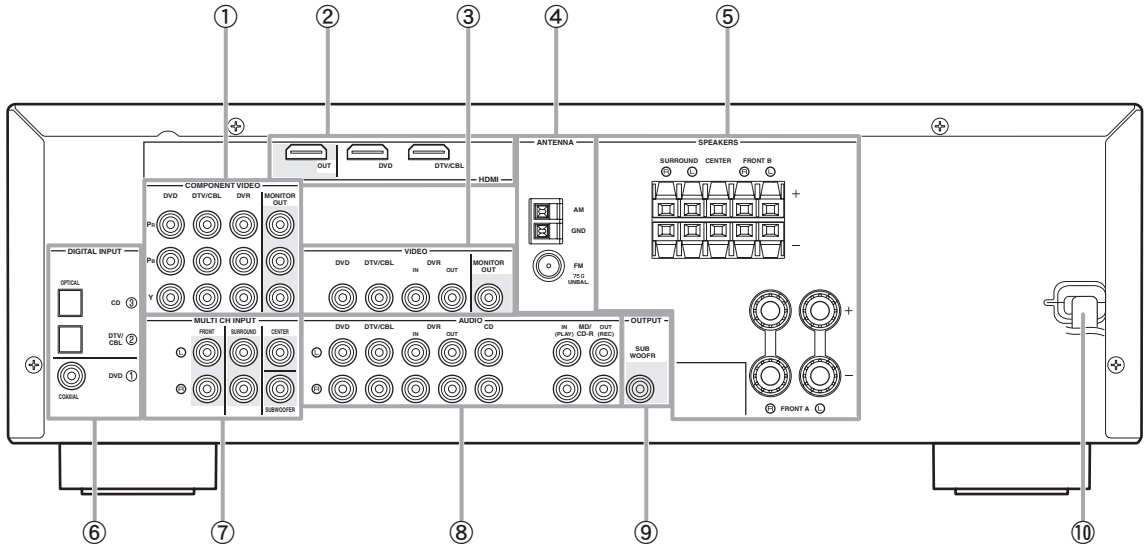

① COMPONENT VIDEO jacks

Connect to Y, PB/CB and PR/CR jacks on your video components with component video cables (see page 11).

- DVD input jacks
- DTV/CBL input jacks
- DVR input jacks
- MONITOR OUT output jacks

② HDMI terminals

Connect to HDMI output/input terminals on your external components with HDMI cables (see page 11).

- HDMI DVD terminal
- HDMI DTV/CBL terminal
- HDMI OUT output terminal

③ VIDEO jacks

Connect to video jacks on your video components with composite video cables (see page 11).

- DVD input jack
- DTV/CBL input jack
- DVR IN jack
- DVR OUT jack
- MONITOR OUT jack

④ ANTENNA terminals

Connect to the supplied FM and AM antennas (see page 15).

⑤ SPEAKERS terminals

Connect to each speakers (see page 9).

- FRONT A L/R
- FRONT B L/R
- SURROUND L/R
- CENTER

⑥ DIGITAL INPUT jacks

Connect to the DIGITAL output jacks on your digital audio components with Coaxial/Optical digital audio cables. This input jacks support PCM, Dolby Digital and DTS bitstream (see page 11).

- COAXIAL (DVD)
- OPTICAL (DTV/CBL)
- OPTICAL (CD)

⑦ MULTI CH INPUT jacks

Connect to the output jacks on your multi-format player or external decoder with analog audio cables (see page 14).

- FRONT L/R jack
- SURROUND L/R jack
- CENTER jack
- SUBWOOFER jack

⑧ AUDIO jacks

Connect to the audio output/input jacks on your components with analog audio cables (see page 11).

- DVD L/R jack
- DTV/CBL L/R jack
- DVR IN L/R jack
- DVR OUT L/R jack
- CD L/R jack
- IN (PLAY) L/R jack
- OUT (REC) L/R jack

⑨ SUBWOOFER OUTPUT jack

Connect to a Subwoofer with an analog audio cable (see page 9).

⑩ Power cable

Connect to a standard AC outlet (see page 15).

Quick start guide

The following steps describe the easiest way to operate this unit. See the related pages for details on the operation and settings.

Step 1: Check the items

In these steps, you need the following items which are not included in the package of this unit.

❑ Speakers

We recommend magnetically shielded speakers.

- ❑ **Front speaker** x 2
At least two front speakers are required to start playback.
- ❑ **Center speaker** x 1
- ❑ **Surround speaker** x 2
- ❑ **Active subwoofer** x 1
Select an active subwoofer equipped with an RCA input jack.
- ❑ **Speaker cable** x 5
- ❑ **Subwoofer cable** x 1
Select a monaural RCA cable.
- ❑ **DVD player** x 1
Select DVD player equipped with coaxial digital audio output jack and composite video output jack.
- ❑ **Video monitor** x 1
Select a TV monitor, video monitor or projector equipped with a composite video input jack.
- ❑ **Video cable** x 2
Select an RCA composite video cable.
- ❑ **Digital coaxial audio cable** x 1

Step 2: Set up your speakers

Place your speakers in the room and connect them to this unit.

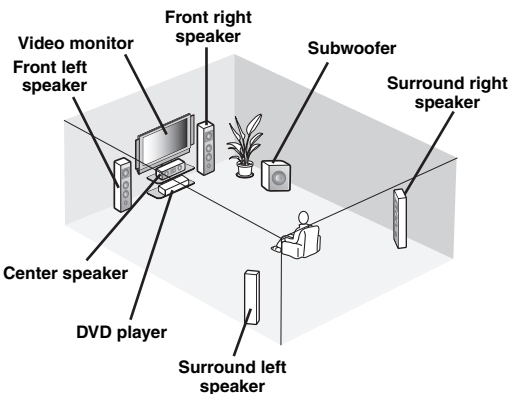

- Placing speakers P. 9
- Connecting speakers P. 9

Step 3: Connect your components

Connect your TV, DVD player or other components.

- Connecting a TV monitor or projector P. 12
- Connecting audio and video components P. 13
- Connecting a multi-format player or an external decoder P. 14
- Using the VIDEO AUX jacks on the front panel P. 14
- Connecting the FM and AM antennas P. 15

Step 4: Turn on the power

Connect the power cable and turn on this unit.

- Connecting the power cable P. 15
- Turning on and off the power P. 15

Step 5: Select the input source and start playback

Select the component connected in the step 3 as an input source and start playback.

- Basic procedure P. 18
- Selecting the SCENE templates P. 22
- Adjusting the sound field programs P. 26

PREPARATION

Preparation of remote control

Installing batteries in the remote control

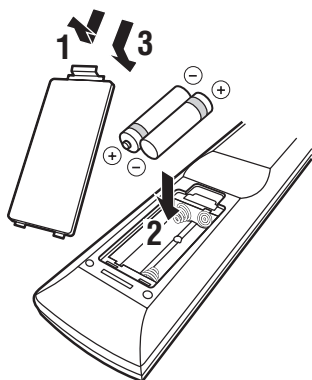

- 1 Take off the battery compartment cover.**
- 2 Insert the four supplied batteries (AAA, R03, UM-4) according to the polarity markings (+ and -) on the inside of the battery compartment.**
- 3 Snap the battery compartment cover back into place.**

Notes

- Change all of the batteries if you notice the following conditions:
 - the operation range of the remote control decreases.
- Do not use old batteries together with new ones.
- Do not use different types of batteries (such as alkaline and manganese batteries) together. Read the packaging carefully as these different types of batteries may have the same shape and color.
- If the batteries have leaked, dispose of them immediately. Avoid touching the leaked material or letting it come into contact with clothing, etc. Clean the battery compartment thoroughly before installing new batteries.
- Do not throw away batteries with general house waste; dispose of them correctly in accordance with your local regulations.
- If the remote control is without batteries for more than 2 minutes, or if exhausted batteries remain in the remote control, the contents of the memory may be cleared. When the memory is cleared, insert new batteries and set up the remote control code.

Using the remote control

The remote control transmits a directional infrared ray. Be sure to aim the remote control directly at the remote control sensor on this unit during operation.

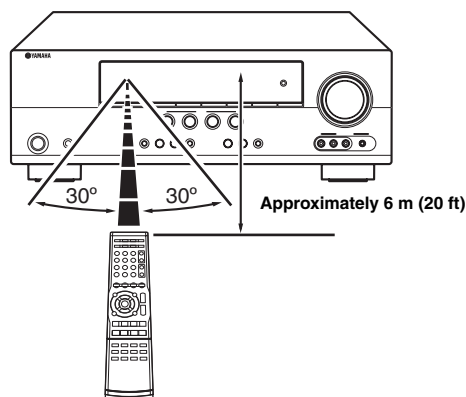

1 Infrared window

Outputs infrared control signals. Aim this window at the component you want to operate.



- To set the remote control codes for other components, see page 38.

Notes

- Do not spill water or other liquids on the remote control.
- Do not drop the remote control.
- Do not leave or store the remote control in the following types of conditions:
 - places of high humidity, such as near a bath
 - places of high temperature, such as near a heater or stove
 - places of extremely low temperatures
 - dusty places
- To set the remote control codes for other components, see page 38.

Connections

Placing speakers

The speaker layout below shows the speaker setting we recommend. You can use it to enjoy CINEMA DSP and multi-channel audio sources.

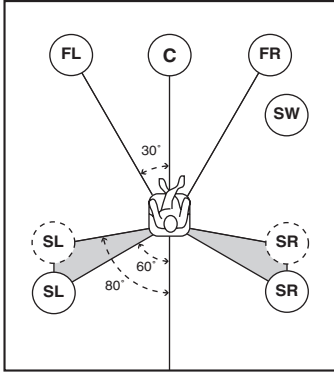

Front left and right speakers (FL and FR)

The front speakers are used for the main source sound plus effect sounds. Place these speakers at an equal distance from the ideal listening position. The distance of each speaker from each side of the video monitor should be the same.

Center speaker (C)

The center speaker is for the center channel sounds (dialog, vocals, etc.). If for some reason it is not practical to use a center speaker, you can do without it. Best results, however, are obtained with the full system.

Surround left and right speakers (SL and SR)

The surround speakers are used for effect and surround sounds.

Subwoofer (SW)

The use of a subwoofer with a built-in amplifier, such as the Yamaha Active Servo Processing Subwoofer System, is effective not only for reinforcing bass frequencies from any or all channels, but also for high fidelity sound reproduction of the LFE (low-frequency effect) channel included in Dolby Digital and DTS sources. The position of the subwoofer is not so critical, because low bass sounds are not highly directional. But it is better to place the subwoofer near the front speakers. Turn it slightly toward the center of the room to reduce wall reflections.

Connecting speakers

Be sure to connect the left channel (L), right channel (R), “+” (red) and “-” (black) properly. If the connections are faulty, this unit cannot reproduce the input sources accurately.

Caution

- Use speakers with the specified impedance shown on the rear panel of this unit.
- Before connecting the speakers, make sure that this the AC power plug is disconnected from the AC wall outlet.
- Do not let the bare speakers wires touch each other or do not let them touch any metal part of this unit. This could damage this unit and/or speakers.
- Use magnetically shielded speakers. If this type of speaker still creates interference with the monitor, place the speakers away from the monitor.

■ 5.1-channel speaker connection

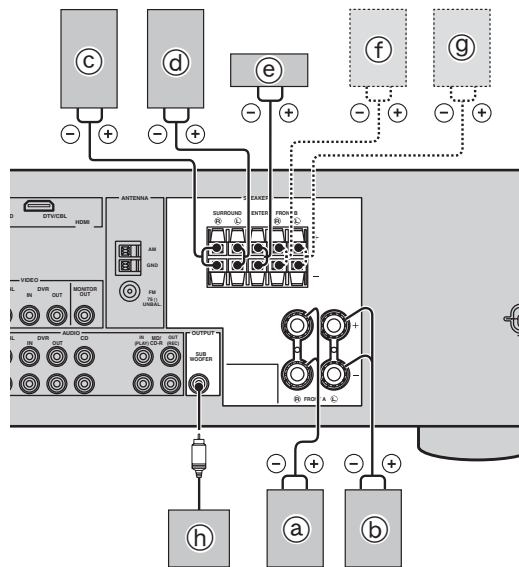

| Speakers | Jacks on this unit |
|----------------------------|--------------------|
| Ⓐ Front speaker (A) Right* | FRONT A (R) |
| Ⓑ Front speaker (A) Left* | FRONT A (L) |
| Ⓒ Surround speaker Right | SURROUND (R) |
| Ⓓ Surround speaker Left | SURROUND (L) |
| Ⓔ Center speaker | CENTER |
| Ⓕ Front speaker (B) Right* | FRONT B (R) |
| Ⓖ Front speaker (B) Left* | FRONT B (L) |
| Ⓗ Subwoofer | SUBWOOFER |

* You can select the front speaker set from Front speakers (A) and Front speakers (B) by pressing **Ⓒ SPEAKERS** repeatedly. See page 19 for details.

■ **Connect speaker cables to each speaker**

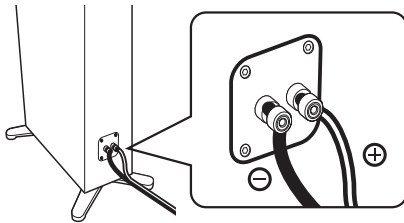

Cables are colored or shaped differently, perhaps with a stripe, groove or ridge. Connect the striped (grooved, etc.) cable to the “+” (red) terminals of your speaker. Connect the plain cable to the “-” (black) terminals.

■ **Before connecting to the SPEAKERS terminal**

A speaker cord is actually a pair of insulated cables running side by side. Cables are colored or shaped differently, perhaps with a stripe, groove or ridges. Connect the striped (grooved, etc.) cable to the “+” (red) terminals of this unit and your speaker. Connect the plain cable to the “-” (black) terminals.

Remove approximately 10 mm (3/8”) of insulation from the end of each speaker cable and then twist the bare wires of the cable together to prevent short circuits.

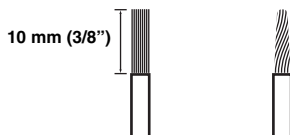

■ **Connecting to the FRONT A terminals**

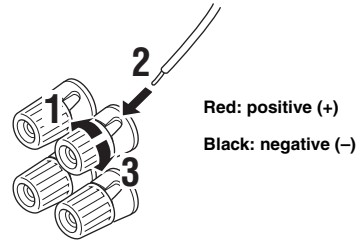

- 1 Loosen the knob.
- 2 Insert the bare end of the speaker wire into the slit on the terminal.
- 3 Tighten the knob to secure the wire.

■ **Connecting to the FRONT B, CENTER, and SURROUND terminals**

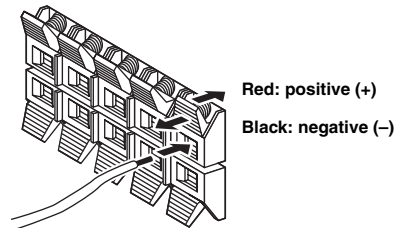

- 1 Press down the tab.
- 2 Insert the bare end of the speaker wire into the hole on the terminal.
- 3 Release the tab to secure the wire.

Connecting video components

Information on jacks and cable plugs

Audio jacks and cable plugs

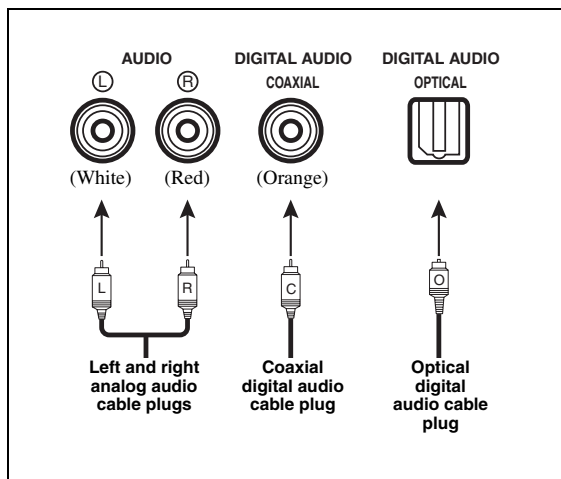

AUDIO jacks

For conventional analog audio signals transmitted via left and right analog audio cables. Connect red plugs to the right jacks and white plugs to the left jacks.

COAXIAL jack

For digital audio signals transmitted via coaxial digital audio cable.

OPTICAL jacks

For digital audio signals transmitted via optical digital audio cables.

Notes

- You can use the digital jacks to input PCM, Dolby Digital, and DTS bitstreams. All digital input jacks are compatible with digital signals with up to 96 kHz of sampling frequency.
- This unit handles digital and analog signals independently. Thus audio signals input at the digital jacks are not output at the analog AUDIO OUT (REC) jack.

Video jacks and cable plugs

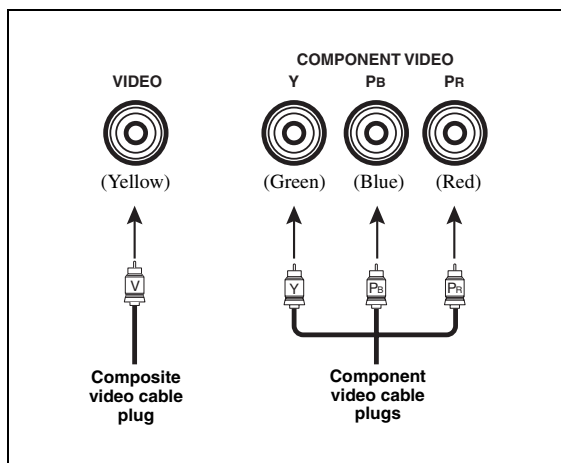

VIDEO jacks

For conventional composite video signals transmitted via composite video cables.

COMPONENT VIDEO jacks

For component signals, separated into the luminance (Y) and chrominance (PB, PR) video signals transmitted on separate wires of component video cables.

Video signal flow for MONITOR OUT

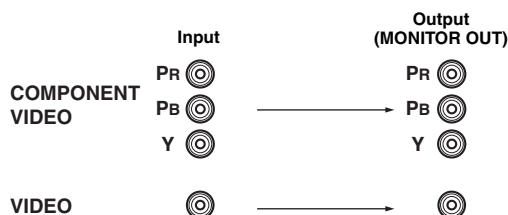

Information on HDMI™

Audio signals input at the HDMI jack are not output from any speaker terminals but output from the connected video monitor. To enjoy the sound from speakers connected to this unit,

- make an analog or digital connection besides the HDMI connection (see page 13).
- mute the volume of the connected video monitor.

You can play back pictures by connecting your video monitor and video source component to this unit using HDMI connections.

At that time, audio/video signals output from the connected component (such as DVD player etc.) are output to the connected video monitor only when this unit is turned on and set to the input source (DVD or DTV/CBL).

Furthermore, available audio/video signals depend on the specification of the connected video monitor. Refer to the instruction manual of each connected component.

HDMI jack and cable plug

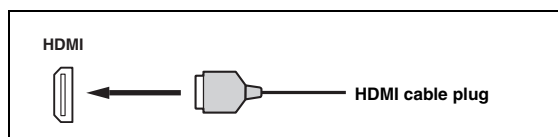

- We recommend using an HDMI cable shorter than 5 meters (16 feet) with the HDMI logo printed on it.
- Use a conversion cable (HDMI jack ↔ DVI-D jack) to connect this unit to other DVI components.

Using the AUDIO OUT REC jack

You can record the audio signal output at the AUDIO OUT (REC) jack by using the recording components.

Note

- Check the copyright laws in your country to record from CDs, radio, etc. Recording of copyrighted material may infringe copyright laws.

Connecting a TV monitor or projector



Make sure that this unit and other components are unplugged from the AC wall outlets.

Note

- If you turn off the video monitor connected to the HDMI OUT jack via a DVI connection, the connection may fail. In this case, the HDMI indicator flashes irregularly.

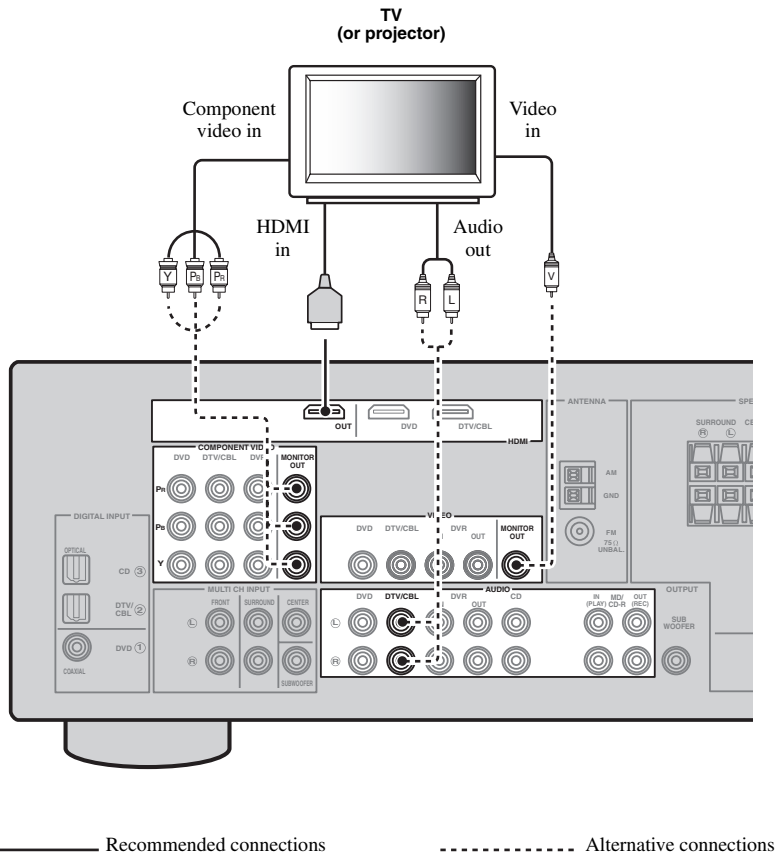

Connecting other components

Connecting audio and video components

This unit has three types of audio jacks, two types of video jacks and HDMI jacks. You can choose the connection method depending on the component to be connected.

■ Connecting example (connecting a DVD player)

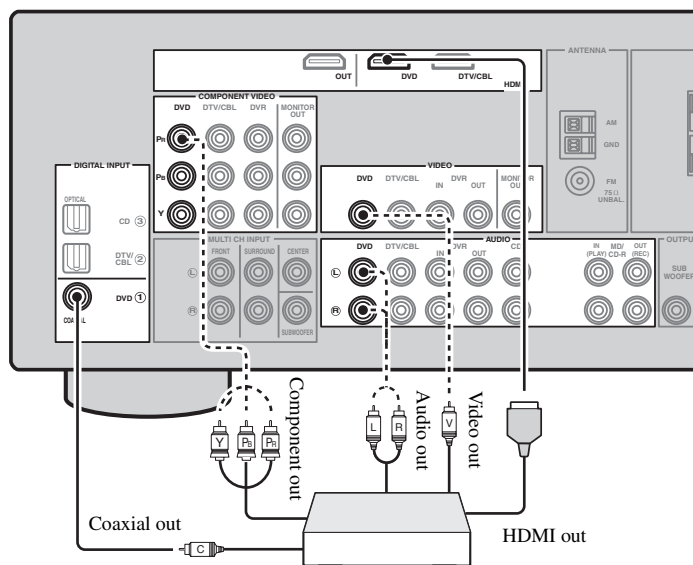

————— Recommended connections

----- Alternative connections

■ Jacks used for audio and video connections

Recommended connections are indicated by (*). When connecting a recording component, you need to make additional connections for recording (signal transmission from this unit to the recording component).



Make sure that this unit and other components are unplugged from the AC wall outlets.



- You can also use the VIDEO AUX jacks (see page 14) on the front panel to connect an additional component.
- To confirm the positions of “jacks on this unit” in the following table, refer to “Rear panel” in “Functional overview” on page 6.

| Component | Signal type | Jacks on component | Jacks on this unit |
|-----------------------------------|-------------|-----------------------|---------------------------|
| DVD player or Blu-ray Disc player | Video | HDMI out* | HDMI (DVD)* |
| | | Component out | COMPONENT VIDEO (DVD) |
| | | Video out (composite) | VIDEO (DVD) |
| | Audio | Optical out* | COAXIAL (DVD)* |
| Audio out (analog) | | AUDIO (DVD) | |
| Set-top box | Video | HDMI out* | HDMI (DTV/CBL)* |
| | | Component out | COMPONENT VIDEO (DTV/CBL) |
| | | Video out (composite) | VIDEO (DTV/CBL) |
| | Audio | Optical out* | OPTICAL (DTV/CBL)* |
| | | Analog out (analog) | AUDIO (DTV/CBL) |

| Component | Signal type | Jacks on component | Jacks on this unit |
|-------------------|-----------------|-----------------------|--------------------|
| DVD recorder | Video | HDMI out* | HDMI (DVR)* |
| | | Video out (composite) | VIDEO (DVR IN) |
| | Audio | Audio out (analog)* | AUDIO (IN (PLAY))* |
| | Audio recording | Audio in (analog)* | AUDIO (OUT (REC))* |
| | Video recording | Video in (composite)* | VIDEO (DVR OUT)* |
| | CD player | Coaxial out* | OPTICAL (CD)* |
| | | Audio out (analog) | AUDIO (CD) |
| MD or CD recorder | Audio | Audio out (analog)* | AUDIO (IN (PLAY))* |
| | Audio recording | Audio in (analog)* | AUDIO (OUT (REC))* |

Notes

- Be sure to make the same type of video connections as those made for your TV if the video conversion is disabled. For example, if you connected your TV to the VIDEO MONITOR OUT jack of this unit, connect other components to the VIDEO jacks.
- Check the copyright laws in your country to record from CDs, radio, etc. Recording of copyrighted material may infringe copyright laws.
- To make a digital connection to a component other than the default one assigned to each DIGITAL INPUT or DIGITAL OUTPUT jack, configure the "INPUT ASSIGN" setting (see page 33).
- Only analog audio signals output at AUDIO OUT (REC) jack can be recorded using the recording components. Therefore Digital signals input at the DIGITAL INPUT jacks or analog signals input at MULTI CH IN jacks can be output at the analog AUDIO OUT (REC) jack for recording.

Connecting a multi-format player or an external decoder

This unit is equipped with 6 additional input jacks (FRONT L/R, SURROUND L/R, CENTER and SUBWOOFER) for discrete multi-channel input from a multi-format player, external decoder or sound processor. Connect the output jacks on your multi-format player or external decoder to the MULTI CH INPUT jacks. Be sure to match the left and right output jacks to the left and right input jacks for the front and surround channels.

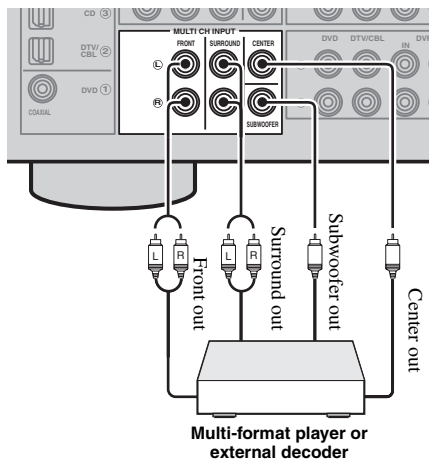

Notes

- When you select the component connected to the MULTI CH INPUT jacks as the input source (see page 19), this unit automatically turns off the digital sound field processor, and you cannot select sound field programs.
- This unit does not redirect signals input at the MULTI CH INPUT jacks to accommodate for missing speakers. We recommend that you connect a 5.1-channel speaker system before using this feature.
- The source connected to the MULTI CH INPUT jacks on this unit cannot be recorded.

Using the VIDEO AUX jacks on the front panel

Use the VIDEO AUX jacks on the front panel to connect a game console or a video camera to this unit. To reproduce the source signals input at these jacks, select "V-AUX" as the input source.

Caution

Be sure to turn down the volume of this unit and other components before making connections.

Note

- The audio signals input at the PORTABLE mini jack take priority over the ones input at the AUDIO L/R jacks.

Connecting the FM and AM antennas

Both FM and AM indoor antennas are supplied with this unit. In general, these antennas should provide sufficient signal strength. Connect each antenna correctly to the designated terminals.

Notes

- The AM loop antenna should be placed away from this unit.
- A properly installed outdoor antenna provides clearer reception than an indoor one. If you experience poor reception quality, install an outdoor antenna. Consult the nearest authorized Yamaha dealer or service center about outdoor antennas.
- The AM loop antenna should always be connected, even if an outdoor AM antenna is connected to this unit.

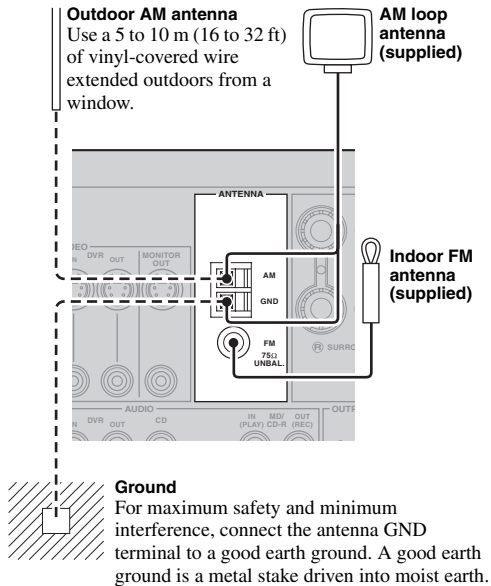

Connecting the wire of the AM loop antenna

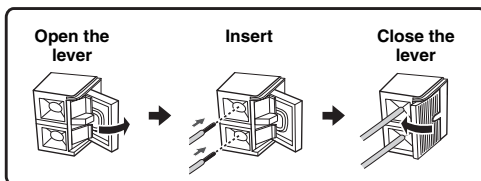

Assembling the supplied AM loop antenna

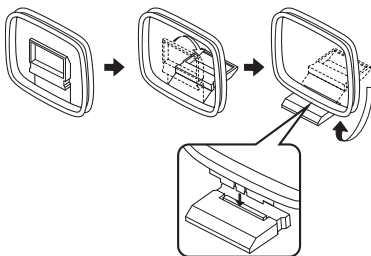

Note

- The types of the supplied AM loop antenna is different depending on the models.

Connecting the power cable

Once all connections are complete, plug the power cable into the AC wall outlet.

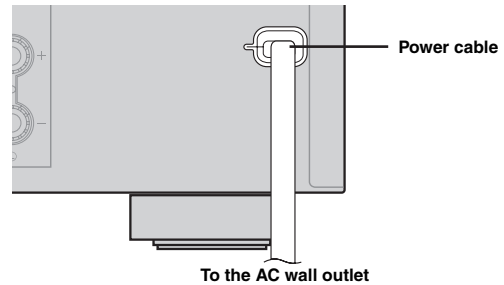

Turning on and off the power

Turning on this unit

Press **(A) STANDBY/ON** (or **[4] POWER**) to turn on this unit.



- When you turn on this unit, there will be a 4 to 5-second delay before this unit can reproduce sound.

Set this unit to the standby mode

Press **(A) STANDBY/ON** (or **[3] STANDBY**) to turn off this unit.

Note

- In the standby mode, this unit consumes a small amount of power in order to receive infrared signals from the remote control.

Optimizing the speaker setting for your listening room (YPAO)

This unit has the Yamaha Parametric Acoustic Optimizer (YPAO). With the YPAO, this unit automatically adjusts output characteristics of your speakers based on speaker positions, speaker performances, and acoustic characteristics of the room. We recommend that you first adjust the output characteristics with the YPAO when you use this unit.

Caution

- Be advised that it is normal for loud test tones to be output during the “AUTO SETUP” procedure. Do not allow small children to enter the room during the procedure.
- To achieve the best results, make sure that the room is as quiet as possible while the “AUTO SETUP” procedure is in progress. If there is too much ambient noise, the results may not be satisfactory.

Using AUTO SETUP



- Initial settings are indicated by (*) in the following each parameter.

1 Make sure of the following check points.

Before starting the automatic setup, check the following check points.

- All speakers and subwoofer are connected appropriately.
- Headphones are disconnected from this unit.
- This unit is turned on.
- The connected subwoofer is tuned on and the volume level is set to about half way (or slightly less).
- FRONT A speakers are selected as the front speaker system (see page 19).
- The room is sufficiently quiet.
- The crossover frequency control of the connected subwoofer is set to the maximum.

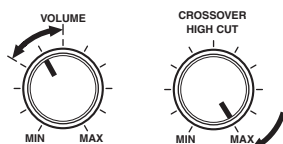

Controls of a subwoofer (example)

2 Connect the supplied optimizer microphone to the OPTIMIZER MIC jack on the front panel.

“SETUP•••••AUTO” appears on the front panel display.

3 Place the optimizer microphone at your normal listening position on a flat level surface with the omni-directional microphone heading upward.

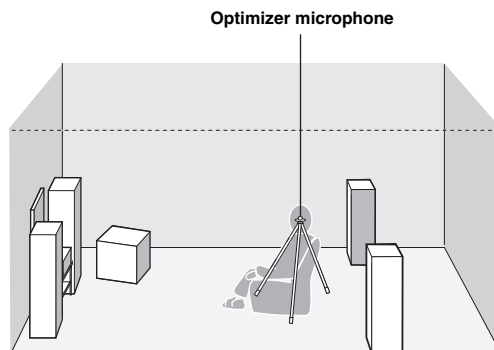

- We recommend that you use a tripod (etc.) to affix the optimizer microphone at the same height as your ears would be when you are seated in your listening position. You can use the attached screw of a tripod (etc.) to fix the optimizer microphone to the tripod (etc.).

4 Press $\boxed{12}$ < / > to select “AUTO.”

| Choice | Function |
|---------|---|
| AUTO* | Automatically runs the entire “AUTO SETUP” procedure. |
| RELOAD | Reloads the last “AUTO SETUP” settings and overrides the previous settings. |
| UNDO | Undoes the last “AUTO SETUP” settings and restores the previous settings. |
| DEFAULT | Resets the “AUTO SETUP” parameters to the initial factory settings. |

Note

- “RELOAD” or “UNDO” is available only when you have previously run “AUTO SETUP” and confirmed the results.

5 Press $\boxed{12}$ ENTER to start the setup procedure.

This unit starts the automatic setup procedure. Loud test tones are output from each speaker during the audio setup procedure. After all settings (“INITIALIZING,” “WIRING/LEVEL,” “DISTANCE,” “SIZE”) are sequentially completed, “FINISH” appears on the front panel display.



- To cancel the automatic setup, press $\boxed{12}$ Δ.

Notes

- During the automatic setup procedure, do not perform any operation on this unit.
- We recommend that you get out of the room while this unit is in the auto setup procedure. It takes approximately 3 minutes for this unit to complete the auto setup procedure.

6 When all measurements are completed successfully, “FINISH” appears on the front panel display.

The result of the automatic setup for each speaker appears in order on the front panel display.

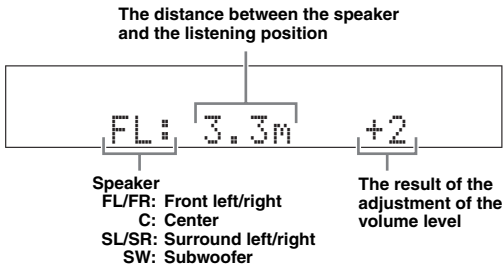

- To display the result of the automatic setup again, press [12]△ / ▽ repeatedly.

Notes

- If you select “RELOAD” in step 4, no test tones are output.
- If an error occurs during the “AUTO:CHECK” procedure, the setup procedure is canceled and an error screen appears. For details, see “If an error screen appears” on page 17.
- When this unit detects potential problems during the “AUTO SETUP” procedure, “WARNING” and the warning messages appear after this unit displays the result of the automatic setup. For details, refer to the “AUTO SETUP” section in “Troubleshooting” on page 43.
- The distance measurement result may be longer than the actual distance depending on the characteristics of your subwoofer.

7 Press [12]◀ / ▶ to select “SET” or “CANCEL.”

| Choice | Function |
|--------|------------------------------------|
| SET* | Confirms the “AUTO SETUP” results. |
| CANCEL | Cancels the “AUTO SETUP” results. |

8 Press [12]ENTER to confirm your selection.
“AUTO SETUP” appears on the front panel display.

9 Press [11]MENU to exit from “SET MENU.”

10 Disconnect the optimizer microphone from this unit.

The optimizer microphone is sensitive to heat. Keep it away from direct sunlight and do not place it on top of this unit.



- If you change speakers, speaker positions, or the layout of your listening environment, run “AUTO SETUP” again to recalibrate your system.
- When you want to check the result of the automatic setup in detail or manually adjust the parameters, use “MANUAL SETUP” (see page 31).

■ If an error screen appears

If this unit detects the potential problems, an error message appears on the front panel display during the automatic setup.

For details about each error message, see the “AUTO SETUP” section in “Troubleshooting” on page 43.

After a few seconds later, the following choices appear. Press [12]◀ / ▶ to select “RETRY” or “EXIT” and then press [12]ENTER.

| Choice | Function |
|--------|--|
| RETRY* | Starts the “AUTO SETUP” again. |
| EXIT | Exits from the “AUTO SETUP” procedure. |

■ If “WARNING” appears

When this unit detects potential problems during the automatic setup procedure, “WARNING” appears on the front panel display after result of each speaker. Check the warning messages to correct your speaker settings.

Note

- Warnings differ from errors in that warnings do not cancel the automatic setup procedure.

Press [12]▽ to display the detailed information about the warning.

The detailed information about the warning is displayed and the indicators of inapplicable speakers blink on the front panel display.



- For details about each warning message, see the “AUTO SETUP” section in “Troubleshooting” on page 43.

BASIC OPERATION

Playback

Caution

Extreme caution should be exercised when you play back CDs encoded in DTS. If you play back a CD encoded in DTS on a DTS-incompatible CD player, you will only hear some unwanted noise that may damage your speakers. Check whether your CD player supports CDs encoded in DTS. Also, check the sound output level of your CD player before you play back a CD encoded in DTS.

Basic procedure

- 1 Turn on external components (TV, DVD player, etc.) connected to this unit.
- 2 Press **Ⓢ** **SPEAKERS** repeatedly to select the front speakers you want to use.
The respective speaker indicators lights up on the front panel display.
- 3 Press **Ⓜ** **INPUT** **◀/▶** repeatedly (or press one of the input selector buttons (**Ⓜ**)) to select the desired input source.
The name of the currently selected input source appears on the front panel display for a few seconds.

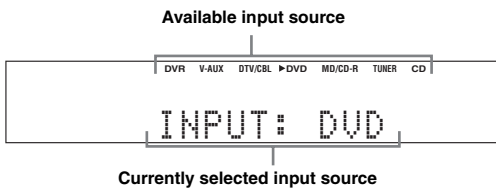

- 4 Start playback on the selected component or select a broadcast station.

Notes

- Refer to the operating instructions for the source component.
- See page 28 for details about FM or AM tuning instructions.



- To adjust the level of each speaker, see page 20.

- 5 Rotate **Ⓢ** **VOLUME** (or press **Ⓢ** **VOLUME +/-**) to adjust the volume to the desired output level.

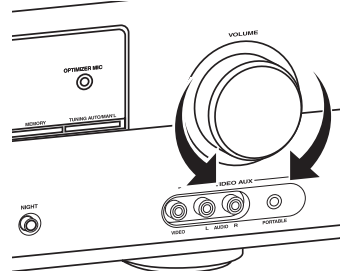

- See page 20 to adjust the level of each speaker.
- This does not affect the AUDIO OUT (REC) level.
- You can set the initial volume level and maximum volume level (see page 33).

- 6 Press **Ⓢ** **PROGRAM** **◀/▶** (or press **Ⓢ** **AMP** and then **Ⓢ** **PROG** **◀/▶**) repeatedly to select the desired sound field program.

The name of the selected sound field program appears on the front panel display.

See page 22 for details about sound field programs.

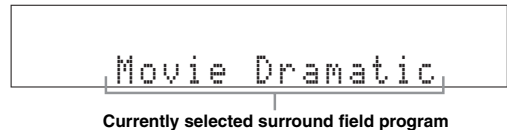

Notes

- Choose a sound field program based on your listening preference, not merely on the name of the program.
- When you select an input source, this unit automatically selects the last sound field program used with the corresponding input source.
- Sound field programs cannot be selected when the component connected to the MULTI CH INPUT jacks is selected as the input source (see page 19).
- When PCM signals with a sampling frequency higher than 48 kHz are input, this unit is automatically set to the "STRAIGHT" mode (see page 27).
- To display information about the currently selected input source on the front panel display, see page 21 for details.

Guide to contents

| When you want... | See page |
|--|----------|
| Adjust the tonal quality of the front speakers | 20 |
| Edit parameters of sound field programs | 27 |
| Enjoy the sources which have wide dynamic range at night | 20 |
| Use headphones | 20 |
| Select a decoder to play back sources with | 27 |
| Set this unit to the standby mode automatically | 21 |

Additional operations

Using input setting features

Use the following features to select input jack or input source.

■ Selecting the front speaker set

Press **Ⓢ****SPEAKERS** repeatedly change the active front speaker set that is connected to the **FRONT A** or **FRONT B** speaker terminals or turn off the front speakers.

The active front speaker set changes as follows:

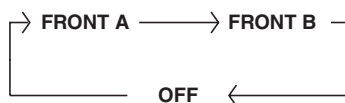

Note

- Turn off the volume level of this unit before you switch the front speaker setting.

■ Using the Zone B feature

When you set “FRONT B” to “ZONE B” (see page 31), you can use the speakers connected to FRONT B speaker terminals in another room (Zone B).

Press **Ⓢ****SPEAKERS** on the front panel repeatedly to turn on or off the Zone B speakers.

When you activate the Zone B speakers, all the speakers in the main room are muted.

Notes

- You cannot activate both the main room and Zone B speakers simultaneously.
- If you select CINEMA DSP sound field program and activate the Zone B speakers, Virtual CINEMA DSP is activated automatically (see page 27).

■ Selecting the component connected to the MULTI CH INPUT jacks as the input source

Use this feature to select the component connected to the MULTI CH INPUT jacks (see page 14) as the input source.

Press **Ⓢ****INPUT** **◀/▶** repeatedly (or press **Ⓢ****AMP** and then press **Ⓢ****MULTI CH IN**) to select “MULTI CH.”

“MULTI CH” appears on the front panel display.



- You can configure the multi channel input settings in “MULTI CH” (see page 34).

Notes

- Sound field programs, or the night listening mode, etc. cannot be selected when “MULTI CH” is selected as the input source.
- When headphones are used, signals are output only from the front left and right channels.

■ Selecting audio input jacks (AUDIO SELECT)

Use this feature (audio input jack select) to switch the input jack assigned to an input source when two or more jacks are assigned to an input source.



- We recommend that you set the audio input jack select to “AUTO” in most cases.
- You can adjust the default audio input jack select of this unit by using “AUDIO SELECT” in “OPTION MENU” (see page 35).

1 Press **Ⓢ****INPUT** **◀/▶** repeatedly (or press one of the input selector buttons (**Ⓢ**)) to select the desired input source.

2 Press **Ⓢ****AMP** and then **Ⓢ****AUDIO SEL** repeatedly to select the desired Audio input jack select setting.



Audio input jack select setting

| Choice | Function |
|--------|--|
| AUTO | Automatically selects input signals in the following order: (1) Digital signals (2) Analog signals |
| ANALOG | Selects only analog signals. If no analog signals are input, no sound is output. |



- You can configure the audio input jack select setting in “AUDIO SELECT.”

Note

- This feature is not available if no digital input jack is assigned to the selected input source in “INPUT ASSIGN” (see page 33).

Using audio features

Use the following features to adjust the audio output or speaker level.

■ Muting the audio output

Press **[5] MUTE** on the remote control to mute the audio output. Press **[5] MUTE** again to resume the audio output.



- You can also rotate **[P] VOLUME** (or press **[13] VOLUME +/-**) to resume the audio output.
- You can configure the muting level by using “MUTE TYP.” in “SOUND MENU” (see page 33).
- The MUTE indicator flashes on the front panel display when the audio output is muted and disappears from the front panel display when the audio output is resumed.

■ Adjusting the tonal quality

Use this feature to adjust the balance of bass and treble for the front left and right speaker channels.

Press **[K] TONE CONTROL** repeatedly to select “BASS” or “TREBLE” and then press **[L] PROGRAM </>** to adjust the corresponding frequency response level.

Control range: -10 dB to +10 dB

Each choice is defined as follows.

| Choice | Function |
|--------|--------------------------------------|
| BASS | Adjusts the low-frequency response. |
| TREBLE | Adjusts the high-frequency response. |

Notes

- Speaker and headphone adjustments are stored independently.
- If you increase or decrease the high-frequency or low-frequency sound to an extreme level, the tonal quality of the surround speakers may not match that of the front left and right speakers.
- This does not affect recorded material.

■ Adjusting the speaker level

You can adjust the output level of each speaker while listening to a music source. This is also possible when playing sources input at the MULTI CH INPUT jacks.

Note

- This operation will override the level adjustment made in “SP LEVEL” (see page 32).

1 Press [8] AMP and then press [10] BAND LEVEL TITLE repeatedly to select the speaker you want to adjust.

| Choice | Description |
|---------|------------------------|
| FRONT L | Front left speaker |
| FRONT R | Front right speaker |
| CENTER | Center speaker |
| SWFR | Subwoofer |
| SUR. L | Surround left speaker |
| SUR. R | Surround right speaker |



- Once you press **[10] BAND LEVEL TITLE** on the remote control, you can also select the speaker by pressing **[12] Δ / ▽**.
- The available speaker channels differ depending on the speaker settings.

2 Press [12] </> on the remote control (or press [F] PRESET/TUNING </>) to adjust the speaker output level.

Control range: -10.0 dB to +10.0 dB

Using optional features

Use the following features to utilize various useful functions equipped on this unit.



- Initial settings are indicated by (*) in this following each parameter.

■ Using your headphones

Connect a pair of headphones with a stereo analog audio cable plug to the PHONES jack on the front panel.



- When you select a sound field program, SILENT CINEMA mode is automatically activated (see page 27).

Notes

- When you connect headphones, no signals are output at the speaker terminals.
- All Dolby Digital and DTS audio signals are mixed down to the left and right headphone channels.

■ Selecting the night listening mode

The night listening modes are designed to improve listenability at lower volumes or at night.

1 Press [O] NIGHT (or press [8] AMP and then [21] NIGHT) repeatedly to select “NIGHT:CINEMA” or “NIGHT:MUSIC.”

Each choice is defined as follows.

| Choice | Function |
|--------------|---|
| NIGHT:CINEMA | Narrows the dynamic range of film soundtracks and makes dialog easier to hear at lower volumes. |
| NIGHT:MUSIC | Preserves ease-of-listening for all sounds. |
| NIGHT OFF | Disables this feature. |



- When a night listening mode is selected, the NIGHT indicator lights up on the front panel display.

2 Press **[12]** </> to adjust the effect level while “NIGHT:CINEMA” or “NIGHT:MUSIC” is displayed on the front panel display.

Each choice is defined as follows.

| Choice | Function |
|--------|---------------------------------------|
| MIN | Slightly lowers the effect level. |
| MID* | Moderately lowers the effect level. |
| MAX | Considerably lowers the effect level. |



- “NIGHT:CINEMA” and “NIGHT:MUSIC” adjustments are stored independently.

Notes

- You cannot use the night listening modes in the following cases:
 - when the component connected to the MULTI CH INPUT jacks is selected as the input source.
 - when headphones are connected to the PHONES jack.
 - when the sampling frequency of the input sources are higher than 48 kHz.
- The effect of night listening modes may vary depending on the input source and surround sound settings you use.

■ Displaying the input source information (SIGNAL INFO)

You can display the format, sampling frequency, channel, bit rate and flag data of the current input signal.

1 Press **[8]** AMP and then press **[11]** MENU on the remote control.

“AUTO SETUP” appears on the front panel display.

• AUTO SETUP

2 Press **[12]** Δ / ▽ repeatedly to select “SIGNAL INFO” and then press **[12]** ENTER.

3 Press **[12]** Δ / ▽ to switch the displayed information.

The following information about the input source appears on the front panel display.

| Choice | Description |
|----------|--|
| FORMAT | Signal format. |
| SAMPLING | The number of samples per second taken from a continuous signal to make discrete signals. |
| CHANNEL | The number of source channels in the input signal (front/surround/LFE). |
| BITRATE | The number of bits passing a given point per second. |
| FLAG | Flag data encoded in DTS, Dolby Digital, or PCM signals that cue this unit to automatically switch decoders. |

4 Press **[11]** MENU on the remote control again to exit from “SET MENU.”

■ Using the sleep timer

Use this feature to automatically set this unit to the standby mode after a certain amount of time. The sleep timer is useful when you are going to sleep while this unit is playing or recording from a source.

Press **[8]** AMP and then press **[24]** SLEEP repeatedly to set the amount of time.

The sleep timer setting changes as follows.

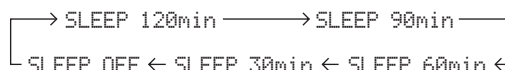

Once the sleep timer is set, the SLEEP indicator lights up on the front panel display, and the display returns to the selected sound field program.

To cancel the sleep timer

Press **[24]** SLEEP on the remote control repeatedly to select “SLEEP OFF.”



- If you set the main zone to the standby mode, the sleep timer is automatically canceled.

■ Playing video sources in the background

You can combine a video image from a video source with sound from an audio source. For example, you can enjoy listening to classical music while viewing beautiful scenery from the video source on the video monitor.

Press the input selector buttons (**[6]**) on the remote control to select a video source and then an audio source.

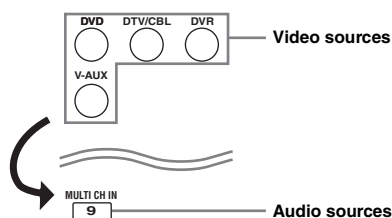
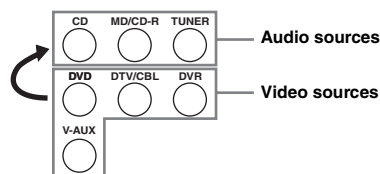

Selecting the SCENE templates

Just by pressing one SCENE button, you can recall your favorite input source and sound field program according to the SCENE template that has been assigned to the SCENE button. The SCENE templates are built combinations of input sources and sound field programs.

This unit is equipped with 12 preset SCENE templates for various situations. The following SCENE templates are assigned to respective SCENE buttons in the default settings.

| Default SCENE button | The name of the SCENE template and its description |
|----------------------|--|
| SCENE 1 | DVD Movie Viewing – input source: DVD – sound field program: STRAIGHT For when you want to enjoy a DVD playback. |
| SCENE 2 | Music Disc Listening – input source: DVD – sound field program: 2ch Stereo For when you want to listen to a music disc from the connected DVD player. |
| SCENE 3 | TV Viewing *1 – input source: DTV/CBL – sound field program: STRAIGHT For when you want to watch a TV program. |
| SCENE 4 | Radio Listening *2, *3, *4 – input source: TUNER – sound field program: Music Enh. 5ch For when you want to listen to a music program from the FM radio station. |

Notes

- *1 You must connect a cable TV or a satellite tuner to this unit in advance. See page 13 for details.
- *2 You need to connect the supplied FM and AM antennas to this unit in advance. See page 15 for details.
- *3 You have to tune into the desired radio station. See pages 28 to 29 for the tuning information.
- *4 To achieve the best possible reception, orient the connected AM loop antenna, or adjust the position of the end of the indoor FM antenna.

If you want to use other SCENE templates, you can select the desired SCENE templates from the SCENE template library and assign the templates to the selected SCENE buttons on the front panel and the remote control.

Select the desired SCENE template

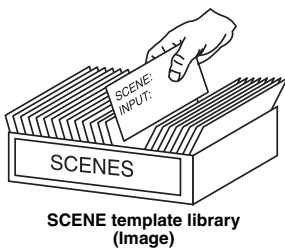

Assign the SCENE template to the SCENE button

Selecting the desired SCENE template

- 1 Press and hold the desired **⏮SCENE** (or **⏭SCENE**) button for 3 seconds.

The MEMORY indicator on the front panel starts to flash, and the name of currently assigned SCENE template appears on the front panel display.

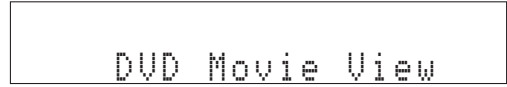

- 2 Press **⏮INPUT** </> (or press **⏮AMP** and then **⏮</>**) to select the desired template.



- 3 Press the **⏮SCENE** (or **⏭SCENE**) button again to confirm the selection.

The MEMORY indicator stops flashing and the select SCENE template is assigned to the button.



- To cancel the procedure, press **⏮AMP** and then **⏮RETURN**.

Note

- Once the desired SCENE templates are assigned to the corresponding SCENE buttons, you may need to set the input source of the SCENE template on the remote control. See page 25 for details.

Which SCENE template would you like to select?

The following tables indicate preset SCENE template descriptions. Select the corresponding SCENE templates for the desired source. The illustrations of the SCENE button in the following table indicate that the SCENE templates in those cells are assigned to the SCENE buttons, respectively.

You can also create your original SCENE templates by editing the preset SCENE templates. See page 24 for details.

■ Video sources (DVD video, Recorded video)

| SCENE template | Input source | Playback mode | Features |
|---|--------------|----------------|--|
| DVD Viewing | DVD | STRAIGHT | Select this SCENE template when you play back general contents on your DVD player. |
|  DVD Movie Viewing | DVD | Movie Dramatic | Select this SCENE template when you play back movies on your DVD player. |
| DVD Live Viewing | DVD | Pop/Rock | Select this SCENE template when you enjoy music live video on your DVD player. |
| DVR Viewing | DVR | Movie Dramatic | Select this SCENE template when you play back movies on your digital video recorder. |

■ Music discs (CD, SA-CD or DVD-Audio)

| SCENE template | Input source | Playback mode | Features |
|--|--------------|---------------|--|
|  Music Disc Listening | DVD | 2ch Stereo | Select this SCENE template when you play back music discs on your DVD player. |
| Disc Listening | DVD | 5ch Stereo | Select this SCENE template when you play back music sources as the back ground music on your DVD player. |
| CD Listening | CD | 5ch Stereo | Select this SCENE template when you play back music source as the back ground music on your CD player. |
| CD Music Listening | CD | 2ch Stereo | Select this SCENE template when you play back music discs on your CD player. |

■ Radio programs

| SCENE template | Input source | Playback mode | Features |
|---|--------------|----------------|--|
|  Radio Listening | TUNER | Music Enh. 5ch | Select this SCENE template when you enjoy FM or AM radio programs. |

■ TV programs

| SCENE template | Input source | Playback mode | Features |
|--|--------------|---------------|--|
|  TV Viewing | DTV/CBL | STRAIGHT | Select this SCENE template when you enjoy TV programs. |
| TV Sports Viewing | DTV/CBL | TV Sports | Select this SCENE template when you enjoy sports programs on TV. |

■ Video games

| SCENE template | Input source | Playback mode | Features |
|----------------|--------------|---------------|---|
| Game Playing | V-AUX | Game | Select this SCENE template when you play video games. |

Creating your original SCENE templates

You can create your original SCENE templates for each SCENE button. Refer to the preset 12 SCENE templates to create the original SCENE templates.

Customizing the preset SCENE templates

Use this feature to customize the preset SCENE templates.

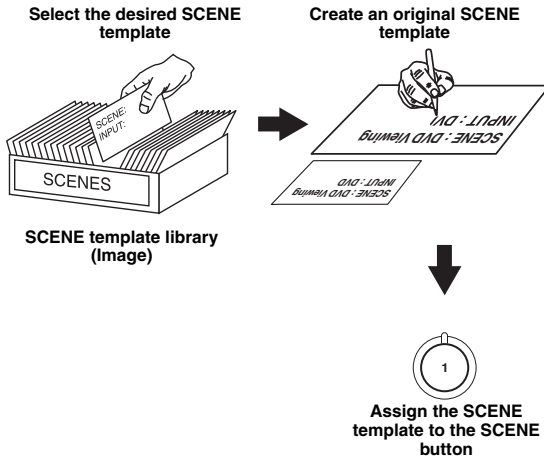

1 Press and hold the desired **[9] SCENE** button for 3 seconds and then press **[8] AMP**.

The MEMORY indicator on the front panel starts to flash.



Note

- When the SCENE template you want to customize is not assigned to any of the **[9] SCENE** button, press **[12] </>** repeatedly to recall the desired SCENE template (see page 22).

2 Press **[12] Δ / ▽** to select the desired parameter of the SCENE template and then **[12] </>** to select the desired value of the selected parameter.

You can adjust the following parameters for a SCENE template:

- The input source component
- The active sound field programs or STRAIGHT mode
- The night listening mode setting (see page 20)
 - SYSTEM: Keeps the current night listening mode.
 - CINEMA: Sets the night listening mode to the CINEMA mode.
 - MUSIC: Sets the night listening mode to the MUSIC mode.

3 Press the **[9] SCENE** button again to confirm the edit.



- An asterisk mark (*) appears by the name of the original SCENE template.
- To cancel the procedure, press **[8] AMP** and then **[14] RETURN**.

Notes

- After changing the assignment of the SCENE template to the **[9] SCENE** buttons, you may need to set the input source of the SCENE template on the remote control. See page 25 for details.
- You can create a customized SCENE template for each **[9] SCENE** button, and if you create another customized SCENE template, this unit overwrites the old customized SCENE template with the new one.
- The customized SCENE template is only available for the assigned **[9] SCENE** button.

Using remote control on the SCENE feature

Controlling the input source components in the SCENE mode

You can operate both this unit and the input source component by using the remote control. You must set the appropriate remote control code for each input source in advance (see page 38).

- 1 Press the desired **[9] SCENE** button on the remote control.
- 2 Press the desired buttons in the * area below to control the input source component of the selected SCENE template.

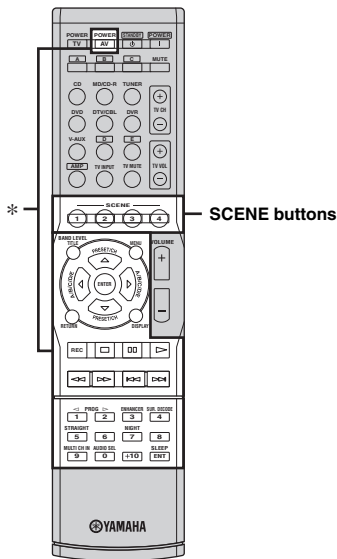

Note

- These buttons control the input source component. See page 36 for details of the function of each button.

Setting input source of the customized SCENE template on the remote control

If you customize the input source of the selected SCENE template, you must set the input source of the SCENE template on the remote control to operate the input source component correctly.

Press and hold the **[9] SCENE** button and the desired input selector button (**[6]**) for 3 seconds.



- Press the **[9] SCENE** button again to operate the input source component.

Sound field programs

This unit is equipped with a variety of precise digital decoders that allow you to enjoy multi-channel playback from almost any stereo or multi-channel sound source. This unit is also equipped with a Yamaha digital sound field processing (DSP) chip containing several sound field programs which you can use to enhance your playback experience.

Selecting sound field programs

Press **L** **PROGRAM** **</>** (or press **8** **AMP** and then press **17** **PROG** **</>** repeatedly).

The name of the selected sound field program appears on the front panel display and on the OSD.

Notes

- When you select an input source, this unit automatically selects the last sound field program used with corresponding input source.
- Sound field programs cannot be selected when the component connected to the MULTI CH INPUT jacks is selected as the input source (see page 19).
- When PCM signals with a sampling frequency higher than 48 kHz are input, this unit is automatically set to the "STRAIGHT" mode (see page 27).



- Choose a sound field program based on your listening preference, not merely on the name of the program itself.
- You can select "Music Enh. 2ch" and "Music Enh. 5ch" by pressing **18** **ENHANCER** repeatedly.

Sound field program descriptions



- Select a sound field program based on your listening preference, not merely on the name of the program, etc.
- The available sound field parameters differ depending on the settings of the speakers.

| Category | Program | Features |
|-----------|----------------------------------|---|
| MUSIC | Pop/Rock | CINEMA DSP processing. This program presents an image of pop, rock, or jazz live concert. The sound field reproduces the spaciousness of a massive pavilion with an emphasis on the vividness of vocals on the stage and solo instruments and the beats of rhythm instruments. |
| | Hall | CINEMA DSP processing. This sound field is suitable for classic and orchestral music. The program uses data collected in a large concert hall in Munich. You can enjoy delicate and beautiful reverberation and a majestic atmosphere. |
| | Jazz | CINEMA DSP processing. The sound field is suitable for jazz and fusion music. It uses data collected in a famous jazz club in New York. You can enjoy clear reverberation. |
| ENTERTAIN | Game | CINEMA DSP processing. You can enjoy dynamic and thrilling sound effects as you play games. The program lets you feel the depth and three-dimensional surrounding sounds of the field where you are playing, and offers cinema-like surrounding sound effects for the scenes of movies. |
| | TV Sports | CINEMA DSP processing. You can enjoy sports relays broadcast in stereo and variety shows with a live sound environment. For sports relays, the voices of commentators and announcers come clearly from the center; the cheers and atmosphere in the stadium spread around within a comfortable range, and you can feel like as if you are in the stadium. |
| MOVIE | Movie Spacious | CINEMA DSP processing. The sound field is suitable for movies with an emphasis on spectacular sound effects, and is a perfect fit with a wide screen. The program reproduces a wide dynamic range from minimum sound effects to powerful sounds. |
| | Movie Dramatic | CINEMA DSP processing. This sound field is also suitable for movies with an emphasis on three-dimensional sound effects. It restrains reverberation to an moderate extent, but reproduces sound effects and background music in a soft, three-dimensional manner with clarity and center orientation of voices as pivots. |
| STEREO | 2ch Stereo | Downmixes multi-channel sources to 2 channel or plays back 2-channel sources as they are. |
| | 5ch Stereo | CINEMA DSP processing. Using this program increases the listening position range. This is a sound field suitable for background music at parties. |
| ENHANCER | Music Enh. 2ch Music Enh. 5ch | Select these programs to play back compression artifacts (such as the MP3 format) in 2-channel or 5-channel stereo. This program enhances your listening experience by regenerating the missing harmonics in a compression artifact. |

■ Selecting decoders for 2-channel sources (surround decode mode)

Signals input from 2-channel sources can also be played back on multi-channels.

Press **[8]AMP** and then press **[19]SUR. DECODE** repeatedly to select a decoder.

You can select from the following decoders depending on the type of source you are playing and your personal preference.

| STANDARD | Function |
|------------|---|
| PRO LOGIC | Dolby Pro Logic processing for any sources |
| PLII Movie | Dolby Pro Logic II processing for movie sources |
| PLII Music | Dolby Pro Logic II processing for music sources |
| PLII Game | Dolby Pro Logic II processing for game sources |

■ Editing sound field parameters

Although you can enjoy good quality sound with the factory default parameters, you can change some of the parameters to better suit the input source or your listening room.

1 While listening to a source, press **[8]AMP** and then press **[12]▲ / ▼** to select desired parameter.

2 Press **[12]◀ / ▶** to change the parameter value.

Note

- You cannot change parameter values when "MEM.GUARD" in "OPTION MENU" is set to "ON" (see page 34).



- Initial settings are indicated by (*) in the following each parameter.

For Pop/Rock, Hall, Jazz, Game, TV Sports, Movie Spacious and Movie Dramatic:

DSP level DSP LEVEL

| | |
|-----------|---------------------------|
| Function: | Adjusts the effect level. |
| Choices: | MIN, MID*, MAX |

For PRO LOGIC II Music:

Panorama PANORAMA

| | |
|-----------|--|
| Function: | Sends stereo signals to the surround speakers as well as the front speakers for a wraparound effect. |
| Choices: | OFF*, ON |

Dimension DIMENSION

| | |
|----------------|---|
| Function: | Gradually adjusts the sound field either towards the front or towards the rear. |
| Control range: | -3 (towards the rear) to +3 (towards the front), initial setting is STD (standard). |

Center width CT WIDTH

| | |
|----------------|--|
| Function: | Adjusts the center image from all three front speakers to varying degrees. A larger value adjusts the center image towards the front left and right speakers. |
| Control range: | 0 (center channel sound is output only from center speaker) to 7 (center channel sound is output only from front left and right speakers), initial setting is 3. |

For Music Enh. 2ch and Music Enh. 5ch

Effect level

| | |
|-----------|---------------------------|
| Function: | Adjusts the effect level. |
| Choices: | LOW, HIGH* |

■ Using sound field programs without surround speakers (Virtual CINEMA DSP)

Virtual CINEMA DSP allows you to enjoy the CINEMA DSP sound field programs without surround speakers.

When you set "SUR. L/R" to "NONE" (see page 32), Virtual CINEMA DSP is activated automatically whenever you select a CINEMA DSP sound field program (see page 26).

■ Enjoying multi-channel sources and sound field programs with headphones (SILENT CINEMA)

SILENT CINEMA allows you to enjoy multi-channel music or movie sound through ordinary headphones. SILENT CINEMA is activated automatically whenever you connect headphones to the PHONES jack while listening to CINEMA DSP sound field programs (see page 26).



- When it is activated, the SILENT CINEMA indicator lights up on the front panel display.

■ Enjoying unprocessed input sources (Straight decoding mode)

When this unit is in the "STRAIGHT" mode, 2-channel stereo sources are output from only the front left and right speakers. Multi-channel sources are decoded straight into the appropriate channels without any additional effect processing.

Press **[M]STRAIGHT** (or press **[8]AMP** and then **[20]STRAIGHT**) to select "STRAIGHT."

"STRAIGHT" appears on the front panel display.

To deactivate the "STRAIGHT" mode

Press **[M]STRAIGHT** (or **[20]STRAIGHT**) again so that "STRAIGHT" disappears from the front panel display.

FM/AM tuning

Overview

You can use two tuning modes to tune into a desired FM/AM station:

■ Frequency tuning mode

You can search or specify the frequency of the desired FM/AM station automatically or manually (see “FM/AM tuning operations” on this page).

■ Preset tuning mode

You can preset the desired FM/AM station in advance, and then recall the station by specifying the preset group and number (see “Selecting preset stations” on page 29).

Note

- Orient the connected AM loop antenna, or adjust the position of the end of the indoor FM antenna for the best reception.

FM/AM tuning operations

- 1 Press **INPUT** $\triangleleft/\triangleright$ repeatedly so that “TUNER” is displayed on the front panel display.
- 2 Press **BAND** to select the reception band (FM or AM).
- 3 To search the station automatically, press **TUNING AUTO/MAN'L** so that the **AUTO** indicator lights up on the front panel display. To search the station manually, press **TUNING AUTO/MAN'L** again so that the **AUTO** indicator disappears from the front panel display.

Lights up during automatic tuning

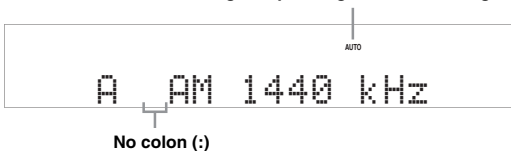

If a colon (:) appears on the front panel display, automatic/manual tuning is not possible. Press **EDIT PRESET/TUNING** to turn the colon (:) off.

- 4 To begin automatic tuning, press **PRESET/TUNING** $\triangleleft/\triangleright$ once. To tune into the desired station manually, press **PRESET/TUNING** $\triangleleft/\triangleright$ repeatedly. When this unit is tuned into a station, the **TUNED** indicator lights up and the frequency of the received station is shown on the front panel display.

Lights up



- To tune into a higher frequency, press **PRESET/TUNING** \triangleright .
- To tune into a lower frequency, press **PRESET/TUNING** \triangleleft .

Note

- If the signal from the station you want to select is weak, tune into it manually.

Preset FM/AM stations

Use this feature to store up to 40 stations (A1 to E8: 8 preset station numbers in each of 5 preset station groups). Preset the desired stations to this unit by using the automatic or manual station preset.

Automatic station preset

You can use the automatic preset tuning feature to store up to 40 FM stations with strong signals in order.

- 1 Press **INPUT** $\triangleleft/\triangleright$ repeatedly so that “TUNER” is displayed on the front panel display.
- 2 Press **BAND** to select “FM” as the reception band.
- 3 Press and hold **MEMORY** for more than 3 seconds. The preset station number as well as the **MEMORY** and **AUTO** indicators flashes. After approximately 5 seconds, automatic presetting status from the current frequency and proceeds toward the higher frequencies.

Flashes

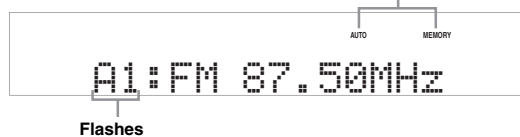

When automatic preset tuning is completed, the front panel display shows the frequency of the last preset station.



- You can select the preset station group and the preset station number where the first received station will be stored by pressing **A/B/C/D/E** and then **PRESET/TUNING** $\triangleleft/\triangleright$.

Notes

- Any stored station data existing under a preset station number is cleared when you store a new station under the same preset station number.
- Only FM stations with sufficient signal strength are stored automatically by automatic preset tuning. If the station you want to store is weak in signal strength, tune it manually and store it as described in “Manual station preset” on this page.

Manual station preset

Use this feature to store the FM or AM stations manually.

1 Tune into a station.

See page 28 for using instructions.

2 Press **MEMORY**.

The MEMORY indicator flashes on the front panel display for approximately 30 seconds.

3 Press **A/B/C/D/E** and **PRESET/TUNING** $\triangleleft/\triangleright$ repeatedly to select a preset station group and number (A1 to E8) while the MEMORY indicator is flashing.

Check that the colon (:) appears on the front panel display.

- To select a higher preset station group and number, press **PRESET/TUNING** \triangleright .
- To select a lower preset station group and number, press **PRESET/TUNING** \triangleleft .

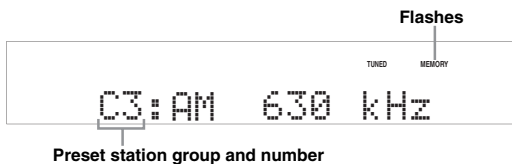

4 Press **MEMORY** while the MEMORY indicator is flashing.

The station band and frequency appear on the front panel display with the preset station group and number you have selected.



Selecting preset stations

You can tune into any desired station simply by selecting the preset station group and number under which it is stored.

When performing this operation with the remote control, press **TUNER** to select “TUNER” as the input source.

1 Press **A/B/C/D/E** (or **12** $\triangleleft/\triangleright$) repeatedly to select the desired preset station group (A to E).

The preset station group letter appears on the front panel display and changes each time you press the button.

2 Press **PRESET/TUNING** $\triangleleft/\triangleright$ (or **12** $\triangleleft/\triangleright$) to select the desired preset station number (1 to 8).

The preset station group and number, along with station band and frequency, appear on the front panel display.



- You can select the desired preset station number (1 to 8) directly by pressing the numeric buttons (25).

Exchanging preset stations

You can exchange the assignments of two preset stations between the two. The example below describes the procedure to exchange preset station “E1” and “A5.”

1 Select preset station “E1” using **A/B/C/D/E** and **PRESET/TUNING** $\triangleleft/\triangleright$.

See “Selecting preset stations” on this page.

2 Press and hold **EDIT PRESET/TUNING** for more than 3 seconds.

“E1” and the MEMORY indicator flash on the front panel display.

3 Select preset station “A5” using **A/B/C/D/E** and **PRESET/TUNING** $\triangleleft/\triangleright$.

“A5” and the MEMORY indicator flash on the front panel display.

See “Selecting preset stations” on this page.



4 Press **EDIT PRESET/TUNING** again.

“EXCHANGE E1-A5” appears on the front panel display and the assignments of the two preset stations are exchanged.

ADVANCED OPERATION

Set menu

You can use the following parameters in the set menu to adjust a variety of system settings and customize the way this unit operates. Change the initial settings to reflect the needs of your listening environment.

Auto setup AUTO SETUP

Use this feature to automatically adjust speaker and system parameters (see page 16).

Manual setup MANUAL SETUP

Use this feature to manually adjust speaker and system parameters.

■ Sound menu 1 SOUND MENU

Use this menu to manually adjust any speaker settings, alter the quality and tone of the sound output by the system or compensate for video signal processing delays when using LCD monitors or projectors.

| Parameter | Features | Page |
|---------------|---|------|
| A>SPEAKER SET | Selects the size of each speaker, the speakers for low-frequency signal output, the crossover frequency, and the location of the front speakers connected to the FRONT B terminals. | 31 |
| B>SP LEVEL | Adjusts the output level of each speaker. | 32 |
| C>SP DISTANCE | Adjusts the distance of each speaker. | 32 |
| D>CENTER GEQ | Adjusts the tonal quality of the center speaker. | 32 |
| E>LFE LEVEL | Adjusts the output level of the LFE channel for Dolby Digital or DTS signals. | 33 |
| F>D. RANGE | Adjusts the dynamic range of Dolby Digital or DTS signals. | 33 |
| G>AUDIO SET | Adjusts the muting level, audio delay settings, maximum volume level and initial volume level. | 33 |

■ Input menu 2 INPUT MENU

Use this menu to manually reassign the input jacks, select the input mode or rename the input source.

| Parameter | Features | Page |
|----------------|---|------|
| A>INPUT ASSIGN | Assigns the input jacks on this unit according to the component to be used. | 33 |
| B>INPUT RENAME | Changes the name of the input source. | 34 |
| C>VOLUME TRIM | Adjusts the output volume of each jack. | 34 |
| D>DECODER MODE | Selects the decoder mode for the sources connected to the DIGITAL INPUT jacks on the rear panel of this unit. | 34 |
| E>MULTI CH SET | Select the video source played in the background of the sources input from the MULTI CH INPUT jacks. | 34 |

■ Option menu 3 OPTION MENU

Use this menu to manually adjust the optional system parameters.

| Parameter | Features | Page |
|----------------|---|------|
| A>DISPLAY SET | Adjusts the brightness of the front panel display. | 34 |
| B>MEMORY GUARD | Locks sound field program parameters and other set menu settings. | 34 |
| C>AUDIO SELECT | Designates the default audio input jack select setting mode for the input sources connected to the DIGITAL INPUT jacks when you turn on the power of this unit. | 35 |
| D>PARAM. INI | Sets all the parameters of the sound field programs to the initial factory settings. | 35 |

Signal information SIGNAL INFO

Use this feature to check audio signal information (see page 21).

Using set menu

Use the remote control to access and adjust each parameter.



- You can change the set menu parameters while this unit is reproducing sound.

1 Press **[8]AMP** and then press **[11]MENU** on the remote control.
“AUTO SETUP” appears on the front panel display.

2 Press **[12]Δ / ▽** to select “MANUAL SETUP.”

▪ MANUAL SETUP

3 Press **[12]ENTER** to enter “MANUAL SETUP.”
“1 SOUND MENU” appears on the front panel display.

1 SOUND MENU

4 Press **[12]Δ / ▽** repeatedly and then press **[12]ENTER** to select and enter the desired menu.

The following menus appear on the front panel display as you press **[12]Δ / ▽** repeatedly.

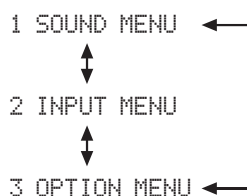

5 Press **[12]Δ / ▽** repeatedly and then press **[12]ENTER** to select and enter the desired submenu.

- Repeat this step to navigate to and enter the items you want to adjust.
- To return to the previous menu level, press **[14]RETURN**.

6 Press **[12]Δ / ▽** to select the desired parameter and then **[12]</>** to change the parameter value.

- Press **[12]▷** to increase the value.
- Press **[12]◁** to decrease the value.

7 Press **[11]MENU** to exit from set menu.

1 SOUND MENU

Use this menu to manually adjust any speaker settings or compensate for video signal processing delays when using LCD monitors or projectors.



- Initial settings are indicated by (*) in this following each parameter.

Speaker settings A)SPEAKER SET

Use this feature to manually adjust any speaker settings.

■ FRONT B speaker setting FRONT B

Use this feature to select the location of the front speakers connected to the FRONT B terminals.

| Choice | Condition |
|--------|--|
| FRONT* | When FRONT B speakers are set in the main zone. |
| ZONE B | When FRONT B speakers are set in another zone. This setting mutes all the speakers in the main room when FRONT B is selected by [C]SPEAKERS . |

Notes

- If you connect headphones to the PHONES jack on this unit, the sound is output from both headphones and the FRONT B terminals while “FRONT B” is set to “ZONE B.”
- If a DSP program is selected when “FRONT B” is set to “ZONE B,” this unit automatically enters the Virtual CINEMA DSP mode (see page 27).

■ Front speakers, Center speaker, Surround left/right speakers

FRONT, CENTER, SUR. LR

Select “LARGE (LRG)” or “SMALL (SML)” depending on the size of your each speaker. When Center speaker or Surround speakers is not connected, select “NONE.”

Initial setting:

FRONT: “LARGE”

CENTER: “SML”

SUR. LR: “SML”

Woofers diameter of a speaker is 16 cm (6.5 in) or larger: LARGE (LRG)
Woofers diameter of a speaker is smaller than 16 cm (6.5 in): SMALL (SML)

Notes

- When “BASS OUT” is set to “FRONT” on this page, you can select only “LARGE” in “FRONT.” If “FRONT” is set to a setting other than “LARGE” in advance, this unit automatically changes the value to “LARGE.”
- When you select “NONE” in “CENTER,” the center channel signals are directed to the front left and right speakers.
- When you select “NONE” in “SUR. LR,” this unit is automatically enters the Virtual CINEMA DSP mode (see page 27).

■ LFE/Bass out BASS OUT

Use this feature to select the speakers that output the LFE (low-frequency effect) and the low-frequency signals.



- If you are not satisfied with the bass sounds from your speakers, you can change these settings according to your preference.

LFE signals output

| Choice | Subwoofer | Front speakers | Other speakers |
|--------|-----------|----------------|----------------|
| BOTH* | Output | No output | No output |
| SWFR | Output | No output | No output |
| FRONT | No output | Output | No output |

Low-frequency signals output

| Choice | Subwoofer | Front speakers | Other speakers |
|--------|-----------|----------------|----------------|
| BOTH* | *1 | *2 | *3 |
| SWFR | *4 | *3 | *3 |
| FRONT | No output | *1 | *3 |

Notes

- *1 Outputs the low-frequency signals of the front channels and other speakers to “SML” or “NONE.”
- *2 Always output the low-frequency signals of the front channels.
- *3 Output the low-frequency signals if the sizes of speakers are set to “LARGE” (or “LRG”).
- *4 Output the low-frequency signals of the speakers set to “SML.”

■ Crossover CROSSOVER

Use this feature to select a crossover frequency of all the speakers set to “SML” (or “SMALL”) or to “NONE” in “SPEAKER SET” (see pages 30 and 31).

Choices: 40Hz, 60Hz, 80Hz*, 90Hz, 100Hz, 110Hz, 120Hz, 160Hz, 200Hz

Note

- All frequencies below the selected frequency will be sent to the subwoofer or to the speakers set to “LRG” (or “LARGE”) in “SPEAKER SET” (see pages 30 and 31).

■ Subwoofer phase SWFR PHASE

Use this feature to switch the phase of your subwoofer if bass sounds are lacking or unclear.

| Choice | Function |
|--------|---|
| NRM* | Does not reverse the phase of your subwoofer. |
| REV | Sets the phase of your subwoofer to reverse. |

Speaker level B)SP LEVEL

Use this feature to manually adjust the output level of each speaker.

Control range: -10 dB to 0 dB* to +10 dB

Control step: 1 dB

| SP LEVEL | Adjusted speaker |
|----------|------------------------|
| FL | Front left speaker |
| FR | Front right speaker |
| C | Center speaker |
| SL | Surround left speaker |
| SR | Surround right speaker |
| SWFR | Subwoofer |

Notes

- The available speaker channels differ depending on the setting of the speakers.
- This does not affect recorded material.

Speaker distance C)SP DISTANCE

Use this feature to manually adjust the distance of each speaker and the delay applied to the respective channel. All sounds would be adjusted to arrive at the listening position at the same time regardless of distance from each speaker.

■ Unit UNIT

| Choice | Condition |
|---------|--|
| meters* | When you adjust speaker distances in meters. |
| feet | When you adjust speaker distances in feet. |

■ Speaker distances

Control range: 0.30 to 24.00 m (1.0 to 80.0 ft)

Control step: 0.10 m (0.5 ft)

Initial setting:

FRONT L/FRONT R/SWFR: 3.00 m (10.0 ft)

CENTER: 2.60 m (8.5 ft)

SUR. L/SUR. R: 2.40 m (8.0 ft)

| SP DISTANCE | Adjusted speaker |
|-------------|------------------------|
| FRONT L | Front left speaker |
| FRONT R | Front right speaker |
| CENTER | Center speaker |
| SUR. L | Surround left speaker |
| SUR. R | Surround right speaker |
| SWFR | Subwoofer |

Note

- The available speaker channels differ depending on the setting of the speakers.

Center graphic equalizer D)CENTER GEO

Use this feature to adjust the built-in 5-frequency band (100Hz, 300Hz, 1kHz, 3kHz and 10kHz) graphic equalizer for the center channel so that the tonal quality of the center speaker matches that of the front speakers.

Control range: -6.0 dB to 0 dB* to +6.0 dB

Control step: 0.5 dB



- Press \square/∇ to select a frequency band and $\square</>$ to adjust the selected frequency band.
- You can make adjustment while listening to the currently source or a test tone.

Following is an example where “100Hz” is selected as the frequency band.

100Hz ---|--- 0

■ Test tone TEST

Use this feature to make adjustments for “CENTER GEQ” while listening to a test tone.

| Choice | Function |
|--------|--|
| OFF* | Stops test tones and output the currently. |
| ON | Outputs test tones from the center and from left speakers. |

Low-frequency effect level E)LFE LEVEL

Use this feature to adjust the output level of the LFE (low-frequency effect) channel according to the capacity of your subwoofer or headphones.

Control range: -20 dB to 0 dB*

Control step: 1 dB

■ Speaker LFE SP LFE

Adjusts the speaker LFE level.

■ Headphone LFE HP LFE

Adjusts the headphone LFE level.

Notes

- Depending on the settings of “BASS OUT” (see page 31), some signals may not be output at the SUBWOOFER OUTPUT jack.
- The LFE channel carries low-frequency special effects which are only added to certain scenes.
- This setting is effective when the input signal contains the LFE channel.

Dynamic range F)D. RANGE

Use this feature to select the amount of dynamic range compression to be applied to your speakers or headphones. This setting is effective only when this unit is decoding Dolby Digital and DTS signals.

| Choice | Function |
|--------|---|
| MIN | Adjusts the dynamic range to narrow. |
| STD | Adjusts the dynamic range to medium. |
| MAX* | Preserves the greatest amount of dynamic range. |

■ Speaker dynamic range SP D.R

Adjusts the speaker compression.

■ Headphone dynamic range HP D.R

Adjusts the headphone compression.

Audio settings G)AUDIO SET

Use this feature to adjust the overall audio settings of this unit.

■ Mute type MUTE TYP.

Use this feature to adjust how much the mute function reduces the output volume (see page 20).

| Choice | Function |
|--------|--|
| FULL* | Completely mutes all the audio output. |
| -20dB | Reduces the current volume by 20 dB. |

■ Audio delay A.DELAY

Use this feature to delay the sound output and synchronize it with the video image. This may be necessary for certain LCD monitors or projectors.

Control range: 0 ms* to 160 ms

Control step: 1 ms

■ Maximum volume MAX VOL.

Use this feature to set the maximum volume level regardless of the original volume range. This feature is useful to avoid the unexpected loud sound.

Control range: +16 dB*, +10 dB to -30 dB

Control step: 5 dB

Note

- The “MAX VOL.” setting takes priority over the “INI.VOL.” setting. For example, if “INI.VOL.” is set to -20 dB and “MAX VOL.” is set to -30 dB, the volume level is automatically set to -30 dB when you turn on the power of this unit next time.

■ Initial volume INI.VOL.

Use this feature to set the volume level when the power of this unit is turned on.

Choices: Off*, -80 dB to +16 dB

Control step: 1 dB

Note

- The “MAX VOL.” setting takes priority over the “INI.VOL.” setting.

2 INPUT MENU

Use this menu to reassign the input jacks, select the input mode or rename the input source.



- Initial settings are indicated by (*) in this following each parameter.

Input assignment A)INPUT ASSIGN

Use this feature to assign the input jacks according to the component to be used if the initial settings of this unit do not correspond to your needs.

Choices: CD, MD/CD-R, DVD, DTV/CBL, V-AUX, DVR

Initial setting:

IN (1) (COAXIAL jack): DVD

IN (2) (OPTICAL (DTV/CBL) jack): DTV/CBL

IN (3) (OPTICAL (CD) jack): CD

Notes

- You cannot select a specific item more than once.
- You cannot assign the same input source to both “IN (2)” and “IN (3).” For example, you assign “CD” to “IN (2),” “----” appears in “IN (3).”
- Once the input jacks are reassigned, you can select the corresponding component by using **INPUT** <|/> (or the input selector buttons (6)) on the remote control).

Input rename B)INPUT RENAME

Use this feature to change the name of the input source that appears on the front panel display.

The following is an example where “DVD” is renamed “My DVD.”



- 1 Press one of the input selector buttons (6) or 22 **MULTI CH IN** to select the input source you want to change the name of.
- 2 Press 8 **AMP** and then press 12 </> on the remote control to place the “_” (underscore) under the space or the character you want to edit.
- 3 Press 12 Δ / ∇ to select the character you want to use and then press 12 </> to move to the next space.

Notes

 - You can use up to 8 characters for each input.
 - Press 12 ∇ to change the character in the following order, or press 12 Δ to go in the reverse order:
A to Z, a space, 0 to 9, a space, a to z, a space, symbols (#, *, -, +, etc.)
- 4 Repeat steps 1 through 3 to rename each input source.
- 5 Press 11 **MENU** to exit from “INPUT RENAME.”

Volume trim C)VOLUME TRIM

Use this feature to adjust the level of the signal input at each jack. This is useful if you want to balance the level of each input source to avoid sudden changes in volume when switching between input sources.

Press one of the input selector buttons (6) or 22 **MULTI CH IN** to select the input source you want to adjust the level.

Choices: CD, TUNER, MD/CD-R, DVD, DTV/CBL, V-AUX, DVR, MULTI CH IN

Control range: -6.0 dB to 0.0 dB* to +6.0 dB

Control step: 1.0 dB

Decoder mode D)DECODER MODE

Decoder select mode

Use this feature to designate the default decoder mode for the input sources connected to the DIGITAL INPUT jacks.

| Choice | Function |
|--------|--|
| AUTO* | Automatically detect the type of input signals and selects the appropriate decoder mode. |
| LAST | Automatically select the last decoder mode used the connected input source. |

DTS decoder prioritize setting

| Choice | Function |
|--------|--|
| AUTO* | Automatically detect the type of input signals and selects the appropriate input mode. |
| DTS | Enables to playback a DTS-CD. |

Multi channel input setup**E)MULTI CH SET**

BGV BGV

Use this feature to select the video source played in the background of the sources input from the MULTI CH INPUT jacks.

Choices: LAST*, DVR, V-AUX, DTV/CBL, DVD



- Select “LAST” to set this unit to automatically select the last selected video source as the background video source.

3 OPTION MENU

Use this menu to adjust the optional system parameters.



- Initial settings are indicated by (*) in this following each parameter.

Display settings A)DISPLAY SET

Dimmer DIMMER

Use this feature to adjust the brightness of the front panel display.

Control range: -4 to 0*

Control step: 1

- Press 12 < to make the front panel display dimmer.
- Press 12 > to make the front panel display brighter.

Memory guard B)MEMORY GUARD

Memory guard MEM.GUARD

Use this feature to prevent accidental changes to DSP program parameter values and other system settings.

| Choice | Function |
|--------|---|
| OFF* | Turns off the “MEM.GUARD” feature. |
| ON | Protects: <ul style="list-style-type: none"> - sound field program parameters - all set menu items - SCENE template parameters |

Note

- When “MEM.GUARD” is set to “ON,” you cannot select and adjust any other set menu items.

Audio select C)AUDIO SELECT

Use this feature to designate the default audio input jack select setting for the input sources.

| Choice | Function |
|--------|---|
| AUTO* | Automatically detect the type of input signals and select the appropriate input mode. |
| LAST | Automatically select the last input mode used for the connected input source (see page 19). |

Parameter initialization D)PARAM. INI

Use this feature to set all the parameters of the sound field programs to the initial factory settings.

| Choice | Function |
|--------|--|
| NO* | Cancels the parameter initialization and returns to the previous menu level. |
| YES | Sets all the sound field parameters to the initial factory settings. |

Notes

- You cannot automatically revert to the previous parameter settings once you initialize the sound field program parameters.
- You cannot separately initialize individual sound field programs.

Remote control features

In addition to controlling this unit, the remote control can also operate other audiovisual components made by Yamaha and other manufacturers. To control your TV or other components, you must set up the appropriate remote control code for each input source (see page 38).

Controlling this unit, a TV, or other components

■ Controlling this unit

Press **[8]AMP** to control this unit.

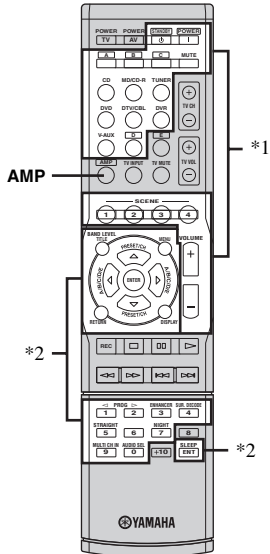

■ Controlling a TV

Press **[6]DTV/CBL** to control your TV. To control your TV, set the appropriate remote control code for **[6]DTV/CBL** (see page 38).

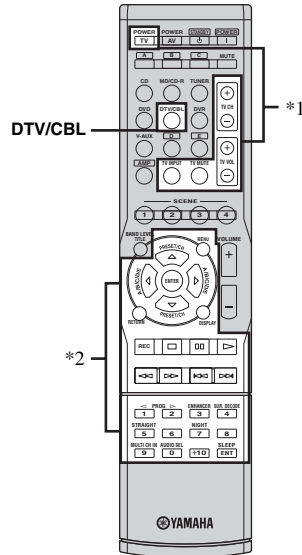

Notes

- *1 These buttons always control this unit.
- *2 These buttons control this unit only when **[8]AMP** is pressed.

Notes

- *1 These buttons always control your TV regardless of whether you press **[6]DTV/CBL** or not.

| Remote control | Digital TV/Cable TV |
|----------------|--|
| TV POWER | Turns on or off the power. |
| TV CH +/- | Changes the channel number. |
| TV VOL +/- | Increases or decreases the volume level. |
| TV INPUT | Changes the input source. |
| TV MUTE | Mutes the audio output. |

- *2 These buttons control your TV only when **[6]DTV/CBL** is pressed. For details, see the “Digital TV/Cable TV” column on page 37.



- You can control more than one TV by setting the appropriate remote control code for any input source selector buttons other than **[6]DTV/CBL**. In such a case, you can control the buttons highlighted above (*1 and *2) when you press the input source selector button.

■ Controlling other components

Press one of the input selector buttons ([6]) or A to E buttons to control other components. You must set the appropriate remote control code for each input source in advance (see page 38). The following table shows the function of each control button used to control other components assigned to each input selector button. Be advised that some buttons may not correctly operate the selected component.



- The remote control has 13 modes (input areas) to control components so that the remote control can operate up to 13 different components.
- When you press one of the optional component control area buttons (A to E), you can control the desired component without changing the input source of this unit.

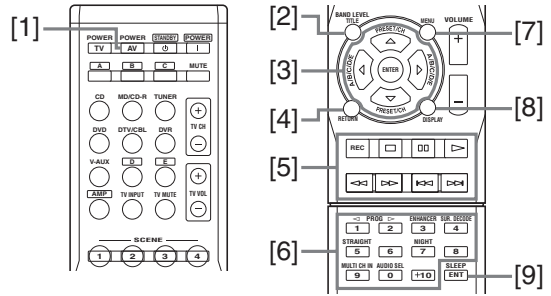

| Remote control | DVD player/ recorder | VCR | Digital TV/ Cable TV | LD player | CD player | MD/CD recorder | Tuner |
|-----------------|---|---------------------|-------------------------|--------------------|--------------------|--------------------|--------------------------|
| [1] AV POWER | Power *1 | Power *1 | Power *2 | Power *1 | Power *1 | Power *1 | |
| [2] TITLE | Title | | | | | | Band |
| [3] PRESET/CH Δ | Up | VCR channel up | Up | | | | Preset up (1-8) |
| PRESET/CH ∇ | Down | VCR channel down | Down | | | | Preset down (1-8) |
| A/B/C/D/E ◀ | Left | | Left | | | | Preset down (A-E) |
| A/B/C/D/E ▶ | Right | | Right | | | | Preset up (A-E) |
| ENTER | Enter | | Enter | | | | |
| [4] RETURN | Return | | Return | | | | |
| [5] REC | Disc skip (player) Rec (recorder) | Rec | Rec *2 | | Disc skip | Rec | |
| ▷ | Play | Play | Play *2 | Play | Play | Play | |
| ◀◀ | Search backward | Search backward | Search backward *2 | Search backward | Search backward | Search backward | |
| ▶▶ | Search forward | Search forward | Search forward *2 | Search forward | Search forward | Search forward | |
| ⏸ | Pause | Pause | Pause *2 | Pause | Pause | Pause | |
| ◀◀ | Skip backward | Skip backward | Skip backward *2 | Skip backward | Skip backward | Skip backward | |
| ▶▶ | Skip forward | Skip forward | Skip forward *2 | Skip forward | Skip forward | Skip forward | |
| ◻ | Stop | Stop | Stop *2 | Stop | Stop | Stop | |
| [6] 1-9, 0, +10 | Numeric buttons | Numeric buttons | Numeric buttons | Numeric buttons | Numeric buttons | Numeric buttons | Preset stations (1-8) |
| [7] MENU | Menu | | Menu | | | | |
| [8] DISPLAY | Display | Display | Display | Display | Display | Display | |
| [9] ENT | Title/Index | Enter | Enter | Chapter/Time | Index | Index | |

Notes

- *1 This button is operational only when the original remote control supplied with the component has a POWER button.
*2 These buttons operate your DVD recorder only when you set the appropriate remote control code for DVR (see page 38).

Setting remote control codes

You can control other components by setting the appropriate remote control codes. For a complete list of available remote control codes, refer to “List of remote control codes” at the end of this manual.

Remote control code default settings

| Input source | Component category | Manufacturer | Default code |
|--------------|--------------------|--------------|--------------|
| CD | CD | Yamaha | 5013 |
| MD/CD-R | CD-R | Yamaha | 5001 |
| TUNER | TUNER | Yamaha | 5007 |
| DVD | DVD | Yamaha | 2000 |
| DTV/CBL | — | — | — |
| V-AUX | TUNER | Yamaha | 5011 |
| DVR | DVR | Yamaha | 2011 |
| A | TUNER | Yamaha | 5012 |
| B | TUNER | Yamaha | 5009 |
| C | TUNER | Yamaha | 5017 |
| D | — | — | — |
| E | — | — | — |

Note

- You may not be able to operate your Yamaha component even if a Yamaha remote control code is preset as listed above. In this case, try setting another Yamaha remote control code.

- While pressing and holding one of the input selector buttons (A-E) on the remote control to select the input area you want to set up, press **AV POWER** for more than 3 seconds.

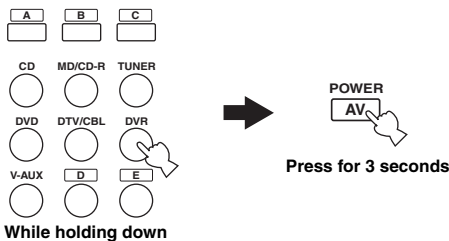

- Press the numeric buttons (0 to 9) (25) to enter the four-digit remote control code for the component to be used.

When the setting succeeds, “RemoteSetup OK” appears; however, when it does not, “RemoteSetup NG” appears on the front panel display.

Notes

- If the manufacturer of your component has more than one code, try each of them until you find the correct one.
- If you do not press any buttons within 30 seconds in step 2, the setup process is canceled. If this happens, repeat the setup procedure.

Resetting all remote control codes

Use this feature to clear all the remote control codes previously set and reset all of them to the initial factory settings.

- While pressing and holding **AMP**, press **AV POWER** for more than 3 seconds.

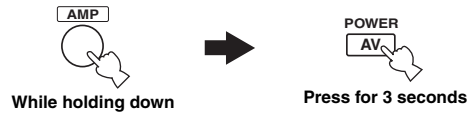

- Press the numeric buttons (25) to enter the code number “9981.”

“RemoteSetup OK” appears on the front panel display, and the remote control codes previously set are cleared and reset to the initial factory settings.



- If you do not press any buttons within 30 seconds after step 1, the clearing process is canceled. In this case, repeat the clearing procedure.

Advanced setup

This unit has additional menus that are displayed on the front panel display. The advanced setup menu offers additional operations to adjust and customize the way this unit operates. Change the initial settings (indicated by (*) in this following parameter) to reflect the needs of your listening environment.

Notes

- Only **STANDBY/ON**, **PROGRAM** $\triangleleft/\triangleright$ and **STRAIGHT** are effective while you are using the advanced setup menu.
- No other operations can be made while you are using the advanced setup menu.
- The advanced setup menu is only available on the front panel display.

1 Press **STANDBY/ON** on the front panel to set this unit to the standby mode.

2 Press and hold **TONE CONTROL** and then press **STANDBY/ON** to turn on this unit.

This unit turns on, and the advanced setup menu appears on the front panel display.

3 Press **PROGRAM** $\triangleleft/\triangleright$ to select the parameter you want to adjust.

The name of the selected parameter appears on the front panel display.

4 Press **STRAIGHT** repeatedly to change the selected parameter setting.

5 Press **STANDBY/ON** to confirm your selection and set this unit to the standby mode.



- The settings you made are reflected next time you turn on this unit.

■ Initializing PRESET

Use this feature to reset all the parameters of this unit to the initial factory settings.

Choices: CANCEL*, RESET

- Select “CANCEL” not to reset any parameters of this unit.
- Select “RESET” to reset the parameters of this unit.

Note

- The initial factory settings are activated next time you turn on this unit.

ADDITIONAL INFORMATION

Troubleshooting

Refer to the table below when this unit does not function properly. If the problem you are experiencing is not listed below or if the instruction below does not help, turn off this unit, disconnect the power cable, and contact the nearest authorized Yamaha dealer or service center.

■ General

| Problem | Cause | Remedy | See page |
|---|--|---|----------|
| This unit fails to turn on or enters the standby mode soon after the power is turned on. | The power cable is not connected or the plug is not completely inserted. | Connect the power cable firmly. | — |
| | The protection circuitry has been activated. | Make sure that all speaker wire connections on this unit and on all speakers are secure and that the wire for each connection does not touch anything other than its respective connection. | 9 |
| | This unit has been exposed to a strong external electric shock (such as lightning or strong static electricity). | Set this unit to the standby mode, disconnect the power cable, plug it back in after 30 seconds and then use it normally. | — |
| No sound | Incorrect input or output cable connections. | Connect the cables properly. If the problem persists, the cables may be defective. | 11-13 |
| | No appropriate Audio input jack select has been set. | Set an appropriate Audio input jack select. | 35 |
| | No appropriate input source has been selected. | Select an appropriate input source with ⓂINPUT <◁/▷> on the front panel (or the input selector buttons (Ⓜ) on the remote control). | 18, 19 |
| | Speaker connections are not secure. | Secure the connections. | 9 |
| | The front speakers to be used have not been selected properly. | Select the front speakers with ⓂSPEAKERS . | 19 |
| | The volume is turned down. | Turn up the volume. | — |
| | The sound is muted. | Press ⓂMUTE or ⓂVOLUME +/- on the remote control to resume audio output and then adjust the volume. | 20 |
| | Signals this unit cannot reproduce are being input from a source component, such as a CD-ROM. | Play a source whose signals can be reproduced by this unit. | — |
| | Audio signals input at the HDMI jack are not output from any speaker terminals. | Make an analog or digital connection beside the HDMI connection. | — |
| | The setting of the connected component is improper. | Make an appropriate setting following the instruction manual of the connected component. | — |
| The sound suddenly goes off. | The protection circuitry has been activated because of a short circuit, etc. | Check that the speaker wires are not touching each other and then turn this unit back on. | — |
| | The sleep timer has turned off this unit. | Turn on this unit, and play the source again. | — |
| | The sound is muted. | Press ⓂMUTE or ⓂVOLUME +/- on the remote control to resume audio output. | 20 |
| Sound is heard from the speaker on one side only. | Incorrect cable connections. | Connect the cables properly. If the problem persists, the cables may be defective. | 11-14 |
| | Incorrect settings in “SP LEVEL.” | Adjust the “SP LEVEL” settings. | 32 |

| Problem | Cause | Remedy | See page |
|--|--|--|----------|
| Only the center speaker outputs substantial sound. | When playing a monaural source with a CINEMA DSP program, the source signal is directed to the center channel, and the front and surround speakers output effect sounds. | | |
| No sound is heard from the center speaker. | “CENTER” in “SPEAKER SET” is set to “NONE.” | Set “CENTER” to “SML” or “LRG.” | 31 |
| | Some sound field programs do not output sounds from the center speaker. | Try another sound field program. | 26 |
| No sound is heard from the surround speakers. | “SUR. LR” in “SPEAKER SET” is set to “NONE.” | Set “SUR. LR” to “SML” or “LRG.” | 31 |
| | This unit is in the “STRAIGHT” mode and a monaural source is being played back. | Press STRAIGHT on the front panel so that “STRAIGHT” disappears from the front panel display. | 27 |
| No sound is heard from the subwoofer. | “BASS OUT” in “SPEAKER SET” is set to “FRONT” when a Dolby Digital or DTS signal is being played. | Set “BASS OUT” to “SWFR” or “BOTH.” | 31 |
| | “BASS OUT” in “SPEAKER SET” is set to “SWFR” or “FRONT” when a 2-channel source is being played. | Set “BASS OUT” to “BOTH.” | 31 |
| | The source does not contain low-frequency bass signals. | | |
| Dolby Digital or DTS sources cannot be played. (Dolby Digital or DTS indicator on the front panel display does not light up.) | The connected component is not set to output Dolby Digital or DTS digital signals. | Make an appropriate setting following the operating instructions for your component. | — |
| | Audio input jack select is set to “ANALOG.” | Set Audio input jack select to “AUTO.” | 19 |
| A humming sound is heard. | Incorrect cable connections. | Connect the audio cables firmly. If the problem persists, the cables may be defective. | — |
| The volume level cannot be increased, or the sound is distorted. | You are attempting to set the volume level higher than the maximum volume level. | Adjust “MAX VOL.” setting. | 33 |
| | The component connected to the AUDIO OUT (REC) jack on this unit is turned off. | Turn on the power of the component. | — |
| The sound effect cannot be recorded. | It is not possible to record the sound effect with a recording component. | | |
| A source cannot be recorded by an analog component connected to the AUDIO OUT (REC) jack. | The source component is not connected to the analog AUDIO IN jacks on this unit. | Connect the source component to the analog AUDIO IN jacks. | 13 |
| The sound field parameters and some other settings of this unit cannot be changed. | “MEM.GUARD” in “OPTION MENU” is set to “ON.” | Set “MEM.GUARD” to “OFF.” | 34 |

| Problem | Cause | Remedy | See page |
|---|---|--|----------|
| This unit does not operate properly. | The internal microcomputer has been frozen by an external electric shock (such as lightning or excessive static electricity) or by a power supply with low voltage. | Disconnect the power cable from the AC wall outlet and then plug it in again after about 30 seconds. | — |
| “CHECK SP WIRES” appears on the front panel display. | Speaker cables are short-circuited. | Make sure all speaker cables are connected correctly. | 9 |
| There is noise interference from digital or radio frequency equipment. | This unit is too close to the digital or high-frequency equipment. | Move this unit further away from such equipment. | — |
| The picture is disturbed. | The video source uses scrambled or encoded signals to prevent dubbing. | | |
| This unit suddenly enters the standby mode. | The internal temperature is too high and the overheat protection circuitry has been activated. | Wait about 1 hour for this unit to cool down and then turn it back on. | — |
| Virtual CINEMA DSP is not activated. | “MULTI CH” is selected as the input source. | Select an input source other than “MULTI CH.” | 18 |
| | Headphones are connected to the PHONES jack. | Disconnect the headphone plug from the PHONES jack. | — |
| | This unit is in the “5ch Stereo” mode. | Exit from the “5ch Stereo” mode. | 26 |
| SILENT CINEMA is not activated. | “MULTI CH” is selected as the input source. | Select an input source other than “MULTI CH.” | 18 |
| | The unit is in the “2ch Stereo,” “STRAIGHT” or “Music Enh.2ch” mode. | Exit from the “2ch Stereo,” “STRAIGHT” or “Music Enh2ch” mode. | 26 |

■ Tuner

| Problem | Cause | Remedy | See page |
|--|---|---|-------------------------|
| FM stereo reception is noisy. | The characteristics of FM stereo broadcasts may cause this problem when the transmitter is too far away or the antenna input is poor. | Check the antenna connections. | 15 |
| | | Try using a high-quality directional FM antenna. | — |
| | | Use the manual tuning method. | 28 |
| FM There is distortion, and clear reception cannot be obtained even with a good FM antenna. | There is multi-path interference. | Adjust the antenna position to eliminate multi-path interference. | — |
| | | The desired station cannot be tuned into with the automatic tuning method. | The signal is too weak. |
| | | Use the manual tuning method. | 28 |
| Previously preset stations can no longer be tuned into. | This unit has been disconnected for a long period. | Set preset stations. | 28 |

| Problem | Cause | Remedy | See page |
|---|--|--|----------|
| The desired station cannot be tuned into with the automatic tuning method. | The signal is weak or the antenna connections are loose. | Tighten the AM loop antenna connections and orient it for the best reception. | — |
| | | Use the manual tuning method. | 28 |
| AM There are continuous crackling and hissing noises. | Noises result from lightning, fluorescent lamps, motors, thermostats and other electrical equipment. | Use an outdoor antenna and a ground wire. This will help somewhat, but it is difficult to eliminate all noise. | — |
| There are buzzing and whining noises. | A TV set is being used nearby. | Move this unit away from the TV set. | — |

■ **AUTO SETUP**

Before AUTO SETUP

| Error message | Cause | Remedy | See page |
|---------------|--|---|----------|
| Connect MIC! | Optimizer microphone is not connected. | Connect the supplied optimizer microphone to the OPTIMIZER MIC jack on the front panel. | 16 |
| Unplug HP! | Headphones are connected. | Unplug the headphones. | — |

During AUTO SETUP

| Error message | Cause | Remedy | See page |
|--------------------------------|---|--|----------|
| NO FRONT L SP NO FRONT R SP | Front L/R channel signals are not detected. | Check the front L/R speaker connections. | 9 |
| NO SUR. L SP NO SUR. R SP | A surround channel signal is not detected. | Check the surround speaker connections. | 9 |
| NOISY | Background noise is too loud. | Try running "AUTO SETUP" in a quiet environment. | — |
| | | Turn off noisy electric equipment like air conditioners or move them away from the optimizer microphone. | — |
| NO MIC | The optimizer microphone was unplugged during the "AUTO SETUP" procedure. | Connect the supplied optimizer microphone to OPTIMIZER MIC jack on the front panel. | 16 |
| USER CANCEL | The "AUTO SETUP" procedure was cancelled due to user activity. | Run "AUTO SETUP" again. | 16 |

After AUTO SETUP

| Warning message | Cause | Remedy | See page |
|-----------------|--|--|----------|
| PHASE REVERSED | Speaker polarity is not correct. This message may appear depending on the speakers even when the speakers are connected correctly. | Check the speaker connections for proper polarity (+ or -). | 9 |
| DISTANCE ERROR | The distance between the nearest speaker and the furthest speaker is out of adjustable range. | Bring the speaker closer to the listening position. | — |
| LEVEL ERROR | The difference of volume level among speakers is excessive. (No level correction is made.) | If “SWFR:TOO LOUD” or “SWFR:TOO LOW” appears, adjust the output volume of the subwoofer. | 16 |
| | | Readjust the speaker installation so that all speakers are set in locations with similar conditions. | — |
| | | Check the speaker connections. | 9 |
| | | Use speakers of similar quality. | — |

Notes

- If the “ERROR” or “WARNING” screens appears, check the cause of the problem, then run “AUTO SETUP” again.
- If a warning message “PHASE REVERSED” appears, corrections are made, but they may not be optimal.
- If a warning message “DISTANCE ERROR” or “LEVEL ERROR” appears, no corrections are made.

■ Remote control

| Problem | Cause | Remedy | See page |
|--|---|---|----------|
| The remote control does not work nor function properly. | Wrong distance or angle. | The remote control functions within a maximum range of 6 m (20 ft) and no more than 30 degrees off-axis from the front panel. | 8 |
| | Direct sunlight or lighting (from an inverter type of fluorescent lamp, etc.) is striking the remote control sensor of this unit. | Reposition this unit. | — |
| | The batteries are weak. | Replace all batteries. | 8 |
| | The remote control code is not correctly set. | Set the remote control code correctly using “List of remote control codes” at the end of this manual. | 38 |
| | | Try setting another code for the same manufacturer using “List of remote control codes” at the end of this manual. | 38 |
| Even if the remote control code is correctly set, there are some models that do not respond to the remote control. | | | |

■ Resetting the system

Use this feature to reset all the parameters of this unit to the initial factory settings. For details about the procedure of resetting the system, see “Initializing” in “Advanced setup” on page 39.

■ Audio information

Dolby Digital

Dolby Digital is a digital surround sound system that gives you completely independent multi-channel audio. With 3 front channels (front L/R and center), and 2 surround stereo channels, Dolby Digital provides 5 full-range audio channels. With an additional channel especially for bass effects, called LFE (Low Frequency Effect), the system has a total of 5.1-channels (LFE is counted as 0.1 channel). By using 2-channel stereo for the surround speakers, more accurate moving sound effects and surround sound environment are possible than with Dolby Surround. The wide dynamic range from maximum to minimum volume reproduced by the 5 full-range channels and the precise sound orientation generated using digital sound processing provide listeners with unprecedented excitement and realism. With this unit, any sound environment from monaural up to a 5.1-channel configuration can be freely selected for your enjoyment.

Dolby Pro Logic II

Dolby Pro Logic II is an improved technique used to decode vast numbers of existing Dolby Surround sources. This new technology enables a discrete 5-channel playback with 2 front left and right channels, 1 center channel, and 2 surround left and right channels instead of only 1 surround channel for conventional Pro Logic technology. There are three modes available: "Music mode" for music sources, "Movie mode" for movie sources and "Game mode" for game sources.

Dolby Surround

Dolby Surround uses a 4-channel analog recording system to reproduce realistic and dynamic sound effects: 2 front left and right channels (stereo), a center channel for dialog (monaural), and a surround channel for special sound effects (monaural). The surround channel reproduces sound within a narrow frequency range. Dolby Surround is widely used with nearly all video tapes and laser discs, and in many TV and cable broadcasts as well. The Dolby Pro Logic decoder built into this unit employs a digital signal processing system that automatically stabilizes the volume on each channel to enhance moving sound effects and directionality.

DTS Digital Surround

DTS digital surround was developed to replace the analog soundtracks of movies with a 5.1-channel digital sound track, and is now rapidly gaining popularity in movie theaters around the world. DTS, Inc. has developed a home theater system so that you can enjoy the depth of sound and natural spatial representation of DTS digital surround in your home. This system produces practically distortion-free 5.1-channel sound (technically, left, right and center channels, 2 surround channels, plus an LFE 0.1 channel as a subwoofer, for a total of 5.1-channels).

LFE 0.1 channel

This channel reproduces low-frequency bass signals. The frequency range of this channel is from 20 Hz to 120 Hz. This channel is counted as 0.1 because it only enforces a low-frequency range compared to the full-range reproduced by the other 5 channels in Dolby Digital or DTS 5.1-channel systems.

PCM (Linear PCM)

Linear PCM is a signal format under which an analog audio signal is digitized, recorded and transmitted without using any compression. This is used as a method of recording CDs and DVD audio. The PCM system uses a technique for sampling the size of the analog signal per very small unit of time. Standing for "Pulse Code Modulation," the analog signal is encoded as pulses and then modulated for recording.

■ Sampling frequency and number of quantized bits

When digitizing an analog audio signal, the number of times the signal is sampled per second is called the sampling frequency, while the degree of fineness when converting the sound level into a numeric value is called the number of quantized bits. The range of rates that can be played back is determined based on the sampling rate, while the dynamic range representing the sound level difference is determined by the number of quantized bits. In principle, the higher the sampling frequency, the wider the range of frequencies that can be played back, and the higher the number of quantized bits, the more finely the sound level can be reproduced.

■ Sound field program information

CINEMA DSP

Since the Dolby Surround and DTS systems were originally designed for use in movie theaters, their effect is best felt in a theater having many speakers designed for acoustic effects. Since home conditions, such as room size, wall material, number of speakers, and so on, can differ so widely, it is inevitable that there are differences in the sound heard. Based on a wealth of actually measured data, Yamaha CINEMA DSP uses Yamaha original DSP technology to combine Dolby Pro Logic, Dolby Digital and DTS systems to provide the audiovisual experience of movie theater in the listening room of your own home.

SILENT CINEMA

Yamaha has developed a natural, realistic sound effect DSP algorithm for headphones. Parameters for headphones have been set for each sound field program so that accurate representations of all the sound field programs can be enjoyed on headphones.

Virtual CINEMA DSP

Yamaha has developed a Virtual CINEMA DSP algorithm that allows you to enjoy DSP surround effects even without any surround speakers by using virtual surround speakers. It is even possible to enjoy Virtual CINEMA DSP using a minimal two-speaker system that does not include a center speaker.

■ Video information

Component video signal

With the component video signal system, the video signal is separated into the Y signal for the luminance and the PB and PR signals for the chrominance. Color can be reproduced more faithfully with this system because each of these signals is independent. The component signal is also called the "color difference signal" because the luminance signal is subtracted from the color signal. A monitor with component input jacks is required in order to output component signals.

Composite video signal

With the composite video signal system, the video signal is composed of three basic elements of a video picture: color, brightness and synchronization data. A composite video jack on a video component transmits these three elements combined.

Specifications

AUDIO SECTION

- Minimum RMS Output Power for Front, Center, Surround
 [U.S.A. and Canada models]
 1 kHz, 0.9% THD, 8 Ω 100 W/ch
 [Other models]
 1 kHz, 0.9% THD, 6 Ω 100 W/ch
- Maximum Power (JEITA)
 [U.S.A. and Canada models]
 1 kHz, 10% THD, 8 Ω 135 W/ch
 [Asia, China, Korea and General models]
 1 kHz, 10% THD, 6 Ω 135 W/ch
- MAX Power Per Channel
 [U.K., Russia, and Europe models]
 1 kHz, 0.7% THD, 4 Ω 105 W or more
- IEC Power
 [U.K., Russia, and Europe models]
 1 kHz, 0.1% THD, 6 Ω 90 W or more
- Dynamic Power
 [U.S.A. and Canada models] (Impedance Selector: 8 Ω)
 (IHF, 8/6/4/2 Ω) 110/130/160/180 W
 [Other models]
 (IHF, 6/4/2 Ω) 105/130/150 W
- Dynamic Headroom [U.S.A. and Canada models]
 8 Ω 0.41 dB
- Frequency Response
 CD, etc. to Front 10 Hz to 100 kHz, 0/-3 dB
 V-AUX to Front 10 Hz to 20 kHz, 0/-3 dB
- Total Harmonic Distortion
 CD, etc. (2ch stereo) to Front SP OUT,
 [U.S.A. and Canada models]
 1 kHz, 50 W/8 Ω 0.06% or less
 [Other models]
 1 kHz, 50 W/6 Ω 0.06% or less
- Signal to Noise Ratio (IHF-A Network)
 CD, etc. (STEREO) Input shorted
 250 mV 100 dB or more
 200 mV 98 dB or more
- Residual Noise (IHF-A Network)
 Front L/R 170 μV or less
- Channel Separation
 CD, etc. Input 5.1 kΩ shorted (1 kHz/10 kHz)
 60 dB/45 dB or more
- Tone Control
 BASS Boost/Cut ±10 dB/100 Hz
 TREBLE Boost/Cut ±10 dB/20 kHz
- Headphone Jack Rated Output/Impedance
 CD, etc. (1 kHz, 200 mV, 8 Ω) 0.4 V/470 Ω
- Input Sensitivity/Input Impedance
 CD, etc. 200 mV/47 kΩ
 MULTI CH INPUT 200 mV/47 kΩ
- Maximum Input Signal
 CD, etc. 1 kHz, 0.5%THD (EFFECT ON) 2.0 V or more
- Output Level/Output Impedance
 AUDIO OUT (REC) 200 mV/1.2 kΩ
 SUBWOOFER OUTPUT
 (2ch Stereo and FRONT SP: SMALL) 4 V/1.2 kΩ
- Filter Characteristics (fc=40/60/80/90/100/110/120/160/200 Hz)
 H.P.F. (Front, Center, Surround) 12 dB/oct.
 L.P.F. (Subwoofer) 24 dB/oct.

VIDEO SECTION

- Signal Level
 Composite 1 V_{p-p}/75 Ω
 Component 1 V_{p-p}/75 Ω (Y), 0.7 V_{p-p}/75 Ω (PB/PR)
- Video Maximum Input Level 1.5 V_{p-p} or more
- Signal to Noise Ratio 50 dB or more
- Frequency Response (MONITOR OUT)
 Component Signal 5 Hz to 60 MHz, -3 dB

FM SECTION

- Tuning Range
 [U.S.A. and Canada models] 87.5 to 107.9 MHz
 [Asia and General models] 87.5/87.50 to 108.0/108.00 MHz
 [Other models] 87.50 to 108.00 MHz
- 50 dB Quieting Sensitivity (IHF, 100% mod.)
 Mono 2.8 μV (20.2 dBf)
- Signal to Noise Ratio (IHF)
 Mono/Stereo 73 dB/70 dB
- Harmonic Distortion (1 kHz)
 Mono/Stereo 0.5%/0.5%

AM SECTION

- Tuning Range
 [U.S.A. and Canada models] 530 to 1710 kHz
 [Asia and General models] 530/531 to 1710/1611 kHz
 [Other models] 531 to 1611 kHz

GENERAL

- Power Supply
 [U.S.A. and Canada models] 120 V AC, 60 Hz
 [Australia model] 240 V AC, 50 Hz
 [Korea model] 220 V AC, 60 Hz
 [China model] 220 V AC, 50 Hz
 [U.K., Russia, and Europe models] 230 V AC, 50 Hz
 [Asia and General models]
 110-120/220-240 V AC, 50/60 Hz
- Power Consumption
 [U.S.A. and Canada models] 240 W/320 VA
 [Other models] 240 W
- Standby Power Consumption
 [Except Asia and General models] 0.8 W
- Maximum Power Consumption
 [Asia and General models]
 5ch, 10%/THD 530 W
- Dimensions (W x H x D) 435 x 151 x 318 mm
 (17-1/8" x 5-15/16" x 12-1/2")
- Weight 8.0 kg (17 lbs 10 oz)

* Specifications are subject to change without notice.

Index

■ Numerics

| | |
|---------------------|--------|
| 1 SOUND MENU | 30, 31 |
| 2 INPUT MENU | 30, 33 |
| 2ch Stereo | 26 |
| 3 OPTION MENU | 30, 34 |
| 5ch Stereo | 26 |

■ A

| | |
|---|--------|
| A)DISPLAY SET | 34 |
| A)INPUT ASSIGN | 33 |
| A)SPEAKER SET | 31 |
| A.DELAY | 33 |
| A/B/C/D/E, front panel | 3 |
| Adjusting the speaker level | 20 |
| Adjusting the tonal quality | 20 |
| AM tuning | 28 |
| AMP, remote control | 5 |
| ANTENNA terminals | 6 |
| Audio cable plugs | 11 |
| Audio delay | 33 |
| AUDIO jacks | 6, 11 |
| Audio jacks | 11 |
| AUDIO L/R (VIDEO AUX) jacks, front panel | 3 |
| AUDIO SEL, remote control | 5 |
| AUDIO SELECT | 19 |
| Audio select | 35 |
| Audio settings | 33 |
| AUTO SETUP | 16, 30 |
| Auto setup | 30 |
| AUTO SETUP, Error message | 43 |
| Automatic preset tuning | 28 |
| Automatic tuning | 28 |

■ B

| | |
|--|----|
| B)INPUT RENAME | 34 |
| B)MEMORY GUARD | 34 |
| B)SP LEVEL | 32 |
| BAND LEVEL TITLE, remote control | 5 |
| BAND, front panel | 3 |
| BASS OUT | 31 |
| BGV | 34 |

■ C

| | |
|--|-------|
| C)AUDIO SELECT | 35 |
| C)SP DISTANCE | 32 |
| C)VOLUME TRIM | 34 |
| CD Listening | 23 |
| CD Music Listening | 23 |
| CENTER | 31 |
| Center graphic equalizer | 32 |
| Center speaker | 31 |
| Center width | 27 |
| CINEMA DSP indicator | 4 |
| COMPONENT VIDEO jacks | 6, 11 |
| Connect MIC!, Auto setup error message | 43 |
| Connecting a DVD player | 13 |
| Connecting a TV | 12 |
| Connecting audio components | 13 |
| Connecting speakers | 9 |
| Connecting the AM antennas | 15 |
| Connecting the FM antennas | 15 |
| Connecting the power cable | 15 |
| Connecting to CD player | 13 |
| Connecting to DVD recorder | 13 |
| Connecting to MD recorder/CD recorder | 13 |
| Connecting to the CENTER terminals | 10 |
| Connecting to the COMPONENT VIDEO jacks | 11 |
| Connecting to the FRONT A terminals | 10 |
| Connecting to the FRONT B terminals | 10 |
| Connecting to the HDMI jacks | 11 |
| Connecting to the MULTI CH INPUT jacks | 14 |
| Connecting to the SURROUND terminals | 10 |
| Connecting video components | 13 |

| | |
|---|----|
| Control buttons, remote control | 5 |
| Creating original SCENE templates | 24 |
| CROSSOVER | 32 |
| Crossover | 32 |
| CT WIDTH | 27 |
| Cursors/ENTER, remote control | 5 |

■ D

| | |
|---|----|
| D)CENTER GEO | 32 |
| D)DECODER MODE | 34 |
| D)PARAM. INI | 35 |
| Decoder indicator | 4 |
| Decoder mode | 34 |
| Decoder select mode | 34 |
| DIGITAL AUDIO COAXIAL jack | 11 |
| DIGITAL AUDIO OPTICAL jacks | 11 |
| DIGITAL INPUT COAXIAL assignment | 33 |
| DIGITAL INPUT jacks | 6 |
| DIMENSION | 27 |
| Dimension | 27 |
| DIMMER | 34 |
| Dimmer | 34 |
| Disc Listening | 23 |
| Display settings | 34 |
| DISPLAY, remote control | 5 |
| DISTANCE ERROR, Auto setup error message | 44 |
| DSP LEVEL | 27 |
| DSP level | 27 |
| DTS decoder prioritize setting | 34 |
| DVD Live Viewing | 23 |
| DVD Movie Viewing | 23 |
| DVD Viewing | 23 |
| DVR Viewing | 23 |
| Dynamic range | 33 |

■ E

| | |
|---|----|
| E)LFE LEVEL | 33 |
| E)MULTI CH SET | 34 |
| EDIT PRESET/TUNING, front panel | 3 |
| Editing sound field parameters | 27 |
| ENHANCER indicator | 4 |
| ENHANCER, remote control | 5 |
| Enjoying 2-channel sources using the standard decoders | 27 |
| Exchanging preset stations | 29 |

■ F

| | |
|-------------------------------|------|
| F)D.RANGE | 33 |
| FM tuning | 28 |
| FRONT | 31 |
| FRONT B | 31 |
| FRONT B speaker setting | 31 |
| Front panel | 3 |
| Front panel display | 3, 4 |
| Front speakers | 31 |

■ G

| | |
|--------------------|----|
| G)AUDIO SET | 33 |
| Game Playing | 23 |

■ H

| | |
|----------------------------------|----|
| Hall | 26 |
| HDMI | 11 |
| HDMI jack, HDMI cable plug | 11 |
| HDMI terminals | 6 |
| Headphone dynamic range | 33 |
| Headphone LFE | 33 |
| Headphones indicator | 4 |
| HP D.R | 33 |
| HP LFE | 33 |

■ I

| | |
|---------------------------------------|----|
| Infrared window | 8 |
| Infrared window, remote control | 5 |
| INI.VOL. | 33 |

| | |
|--|----|
| Initial volume | 33 |
| Initializing | 39 |
| Input assignment | 33 |
| Input channel and speaker indicators | 4 |
| Input channel indicators | 4 |
| Input menu | 30 |
| Input rename | 34 |
| Input selector buttons, remote control | 5 |
| Input source indicators | 4 |
| Input source information | 21 |
| INPUT, front panel | 3 |
| Installing batteries in the remote control | 8 |

■ J

| | |
|------------|----|
| Jazz | 26 |
|------------|----|

■ L

| | |
|--|----|
| LEVEL ERROR, Auto setup error message | 44 |
| LFE indicator | 4 |
| LFE/Bass out | 31 |
| Listening to unprocessed input signals | 27 |
| Low-frequency effect level | 33 |

■ M

| | |
|---|----|
| Manual preset tuning | 29 |
| MANUAL SETUP | 30 |
| Manual setup | 30 |
| Manual tuning | 28 |
| MAX VOL. | 33 |
| Maximum volume | 33 |
| MEM.GUARD | 34 |
| Memory guard | 34 |
| MEMORY, front panel | 3 |
| MENU, remote control | 5 |
| Movie Dramatic | 26 |
| Movie Spacious | 26 |
| MULTI CH IN, remote control | 5 |
| MULTI CH INPUT jacks | 6 |
| Multi channel input setup | 34 |
| Multi-channel sources and sound field programs with headphones | 27 |
| Multi-information display | 4 |
| Music Disc Listening | 23 |
| Music Enh. 2ch | 26 |
| Music Enh. 5ch | 26 |
| MUTE indicator | 4 |
| MUTE TYP. | 33 |
| Mute type | 33 |
| MUTE, remote control | 5 |
| Muting the audio output | 20 |

■ N

| | |
|--|----|
| NIGHT indicator | 4 |
| Night listening mode | 20 |
| NIGHT, front panel | 3 |
| NIGHT, remote control | 5 |
| NO FRONT L SP, Auto setup error message | 43 |
| NO FRONT R SP, Auto setup error message | 43 |
| NO MIC, Auto setup error message | 43 |
| NO SUR.L SP, Auto setup error message | 43 |
| NO SUR.R SP, Auto setup error message | 43 |
| NOISY, Auto setup error message | 43 |
| Numeric buttons, remote control | 5 |

■ O

| | |
|--|----|
| OPTIMIZER MIC jack, Auto setup | 16 |
| OPTIMIZER MIC jack, front panel | 3 |
| Optimizer microphone | 16 |
| Optimizer microphone, Auto setup | 16 |
| Optimizing speaker setting | 16 |
| Option menu | 30 |

■ P

| | |
|---|----|
| PANORAMA | 27 |
| Panorama | 27 |
| Parameter initialization | 35 |
| PCM indicator | 4 |
| PHASE REVERSED, Auto setup error message | 44 |
| PHONES jack, front panel | 3 |
| Placing speakers | 9 |
| Playing video sources in the background | 21 |
| Pop/Rock | 26 |
| PORTABLE (VIDEO AUX) jack, front panel | 3 |
| Power cable | 6 |
| POWER, remote control | 5 |
| PRESET | 39 |
| Preset SCENE templates | 23 |
| PRESET/TUNING, front panel | 3 |
| PROG, remote control | 5 |
| PROGRAM, front panel | 3 |

■ R

| | |
|------------------------------|----|
| Radio Listening | 23 |
| Rear panel | 6 |
| Remote control | 5 |
| Resetting the system | 39 |
| RETURN, remote control | 5 |

■ S

| | |
|--|----|
| SCENE | 22 |
| SCENE 1/2/3/4, front panel | 3 |
| SCENE 1/2/3/4, remote control | 5 |
| Selecting audio input jacks | 19 |
| Selecting preset stations | 29 |
| Selecting the MULTI CH INPUT component as the input source | 19 |
| Selecting the night listening mode | 20 |
| Selecting the SCENE templates | 22 |
| Set menu | 30 |
| Set this unit to the standby mode | 15 |
| Setting input source of the customized SCENE template on the remote control | 25 |
| Setting remote control codes | 38 |
| SIGNAL INFO | 21 |
| Signal information | 30 |
| SILENT CINEMA | 27 |
| SILENT CINEMA indicator | 4 |
| SLEEP indicator | 4 |
| Sleep timer | 21 |
| SLEEP, remote control | 5 |
| Sound field programs | 26 |
| Sound menu | 30 |
| SP A B indicators | 4 |
| SP D.R | 33 |
| SP LFE | 33 |
| Speaker distance | 32 |
| Speaker distances | 32 |
| Speaker dynamic range | 33 |
| Speaker level | 32 |
| Speaker LFE | 33 |
| Speaker settings | 31 |
| SPEAKERS terminals | 6 |
| SPEAKERS, front panel | 3 |
| Specifications | 46 |
| STANDBY, remote control | 5 |
| STANDBY/ON, front panel | 3 |
| Straight decoding mode | 27 |
| STRAIGHT, front panel | 3 |
| STRAIGHT, remote control | 5 |
| SUBWOOFER OUTPUT jack | 6 |
| Subwoofer phase | 32 |
| Supplied accessories | 2 |
| SUR. LR | 31 |
| SUR.DECODE, remote control | 5 |
| Surround left/right speakers | 31 |
| SWFR PHASE | 32 |

■ T

| | |
|--|----|
| TEST | 33 |
| Test tone | 33 |
| TONE CONTROL, front panel | 3 |
| Troubleshooting | 40 |
| Tuner indicators | 4 |
| TUNING AUTO/MAN'L, front panel | 3 |
| Turning off the power | 15 |
| Turning on the power | 15 |
| TV control buttons, remote control | 5 |
| TV Sports | 26 |
| TV Sports Viewing | 23 |
| TV Viewing | 23 |
| TV/AV POWER, remote control | 5 |

■ U

| | |
|--|----|
| UNIT | 32 |
| Unit | 32 |
| Unplug HP!, Auto setup error message | 43 |
| USER CANCEL, Auto setup error message | 43 |
| Using the remote control | 8 |
| Using the VIDEO AUX jacks | 14 |
| Using your headphones | 20 |

■ V

| | |
|---|-------|
| VIDEO (VIDEO AUX) jack, front panel | 3 |
| Video cable plugs | 11 |
| VIDEO jacks | 6, 11 |
| Video jacks | 11 |
| Virtual CINEMA DSP | 27 |
| VIRTUAL indicator | 4 |
| VOLUME +/-, remote control | 5 |
| VOLUME control, front panel | 3 |
| VOLUME level indicator | 4 |
| Volume Trim | 34 |

■ Y

| | |
|---|----|
| Yamaha Parametric Room Acoustic Optimizer | 16 |
| YPAO | 16 |
| YPAO (Yamaha Parametric Room Acoustic Optimizer) | 16 |
| YPAO indicator | 4 |

■ Z

| | |
|--------------|----|
| Zone B | 19 |
|--------------|----|

“(A) **STANDBY/ON**” or
“(6) **DVD**” (example) indicates the
name of the parts on the front panel
or the remote control. Refer to
“Functional overview” on page 3.

List of remote control codes

Blu-ray Player

Samsung 2137

CD Player

Yamaha 5000, 5013

CD Recorder

Yamaha 5001

DVD

Acoustic Solutions

2078
 Aiwa 2055, 2100
 Akai 2096
 Akura 2076
 Alba 2078, 2086
 Apex 2027, 2049
 Awa 2078
 Axion 2078
 Brainwave 2096
 Brandt 2073, 2085
 Broksonic 2060
 Bush 2075, 2078, 2112
 Centrex 2077
 Classic 2078
 Clatronic 2075
 Coby 2078
 C-Tech 2074
 CyberHome 2025, 2079, 2091
 Daewoo 2092, 2098
 Dansai 2096
 Daytek 2080, 2089
 DEC 2075
 Denon 2030, 2102, 2103
 Denver 2075, 2076
 Diamond 2074
 DK Digital 2094
 Dual 2078
 D-Vision 2096
 DVX 2074
 Elta 2096
 Euroline 2096
 Funai 2052, 2058
 Global Solutions 2074
 Global Sphere 2074
 Goodmans 2075, 2077, 2078
 Grundig 2077, 2098
 H&B 2075
 Haaz 2074
 HE 2078
 Hitachi 2032, 2072
 Home Electronics 2078
 Innovation 2072
 Irradio 2134
 JDB 2078
 JVC 2033, 2045, 2053, 2073, 2099
 Kenwood 2030, 2097
 Kingavon 2075
 Koda 2075
 Lawson 2074
 Lenco 2075
 LG 2084, 2087
 Lifetec 2072
 Limit 2074
 LogicLab 2074
 Luxor 2077
 Magnavox 2037, 2073, 2075
 Magnum 2072

MBO 2078
 Medion 2072
 Micromaxx 2072
 Micromedia 2073
 Microstar 2072
 Mitsubishi 2035
 Mizuda 2075
 Mustek 2078
 Naiko 2077
 Onkyo 2073, 2135
 Orava 2075
 P&B 2075
 Pacific 2074
 Panasonic 2030, 2040, 2054, 2057, 2105, 2110
 Philips 2019, 2026, 2046, 2073, 2081, 2090
 Pioneer 2036, 2082
 Proline 2077
 Provision 2075
 RCA 2031, 2042, 2050, 2051
 Red Star 2076
 Reoc 2074
 Roadstar 2075, 2078, 2086
 Rowa 2077
 Saba 2085
 Sabaki 2074
 Samsung 2032, 2041, 2104, 2113
 Sansui 2074
 Sanyo 2095
 ScanMagic 2078
 Scientific Labs 2074
 Scott 2088
 SEG 2074, 2086
 Sharp 2034, 2043, 2059, 2093, 2106
 Silva 2076
 Singer 2074
 Skymaster 2074, 2078
 Skyworth 2076
 SM Electronic 2074, 2078
 Sony 2028, 2029, 2039, 2083, 2107
 Soundmaster 2074
 Soundmax 2074
 Standard 2074
 Star Cluster 2074
 Starmedia 2075
 Supervision 2074, 2078
 Sylvania 2052, 2058
 Synn 2074
 TCM 2072
 Teac 2074
 Tec 2076
 Technics 2030
 Technika 2096
 Technosonic 2096
 Tevion 2072, 2074
 Thomson 2085, 2109
 Tokai 2076
 Toshiba 2026, 2044, 2048, 2056, 2073, 2108, 2111
 United 2078
 Voxson 2078
 Wharfedale 2074
 Xlogic 2074
 Yakumo 2077
 Yamada 2077

Yamaha 2000, 2001, 2003, 2030, 2101
 Yukai 2078
 Zenith 2038, 2047, 2073

DVD Recorder

Apex 2024
 JVC 2070
 LG 2071
 Panasonic 2020, 2065, 2066, 2067
 Philips 2019, 2061, 2062, 2063
 Pioneer 2021
 RCA 2018
 Sony 2022, 2064
 Toshiba 2068
 Yamaha 2023
 Yukai 2069

DVD/LD

Pioneer 2036

DVD/VCR

JVC 1017, 2045
 LG 1071, 2087
 Panasonic 1020, 1072, 2040, 2105
 Philips 1025
 RCA 1022, 2042
 Samsung 1021, 2041, 2104
 Sharp 1023, 1073, 2043, 2106
 Sony 1019, 1074, 2039, 2107
 Toshiba 1024, 1075, 2044, 2108
 Zenith 1026, 2047

DVD/DVR

Panasonic 2067
 Pioneer 2114
 Samsung 2115
 Toshiba 2068

DVR

ABS 2132
 Alienware 2132
 CyberPower 2132
 Dell 2132
 DIRECTV 2123, 2128, 2129, 2133
 DISH Network 2126, 2127
 Dishpro 2126
 Echostar 2126, 2127
 Expressvu 2126
 Gateway 2132
 GOI 2126
 Hewlett Packard 2132
 Hitachi 2008
 Howard Computers 2132
 HTS 2126
 Hughes 2123, 2128
 Humax 2123
 Hush 2132
 iBUYPOWER 2132
 JVC 2126, 2127
 Linksys 2132
 Media Center PC 2132

Microsoft 2132
 Mind 2132
 Niveus Media 2132
 Northgate 2132
 Panasonic 2015, 2016, 2017, 2120
 Philips 2117, 2121, 2123, 2128
 Pioneer 2012, 2013, 2014
 Proscan 2129
 RCA 2116, 2124, 2129, 2133
 ReplayTV 2118, 2119, 2120
 Sharp 2009, 2010
 Sonic Blue 2119, 2120
 Sony 2005, 2006, 2007, 2122, 2130, 2131, 2132
 Stack 10 2132
 Stack 9 2132
 Systemax 2132
 Tagar Systems 2132
 Tivo 2116, 2121, 2122, 2123, 2130, 2131
 Toshiba 2004, 2125, 2132
 Touch 2132
 UltimateTV 2133
 Viewsonic 2132
 Voodoo 2132
 Yamaha 2011
 ZT Group 2132

HD DVD

Toshiba 2136

iPod

Yamaha 5011

LD Player

Yamaha 2002

MD

Yamaha 5002, 5003, 5004

Tape Deck

Yamaha 5005, 5006

Tuner

Yamaha 5007, 5008, 5009, 5010, 5012, 5014, 5015, 5016, 5017, 5018

TV

Acer 0093
 Acme 0207
 Acura 0208
 ADA 0255
 ADC 0206
 Admiral 0058, 0205, 0206, 0210, 0211
 Adyson 0200, 0207
 Agashi 0200
 Agazi 0206
 AGB 0204
 Aiko 0127, 0200, 0207, 0208
 Aiwa 0028, 0139, 0229, 0237

| | | | | | | | |
|----------------|--|--------------------|--|------------------|------------------------------------|----------------|--|
| Akai | 0059, 0065, 0127, 0129, 0130, 0200, 0204, 0208, 0209, 0213, 0217, 0218, 0255 | Cascade | 0208 | Envision | 0060, 0061 | Hisawa | 0209, 0218 |
| Akiba | 0209, 0218 | Cathay | 0213, 0217 | Erres | 0213, 0217 | Hitachi | 0006, 0014, 0015, 0016, 0042, 0060, 0061, 0095, 0105, 0127, 0156, 0179, 0180, 0204, 0207, 0210, 0211, 0215, 0216, 0251 |
| Akura | 0206, 0209, 0218 | CCE | 0127 | ESA | 0080 | | |
| Alaron | 0200 | Celebrity | 0059 | Etron | 0208 | | |
| Alba | 0200, 0207, 0208, 0209, 0217, 0218 | Centurion | 0213, 0217 | Euro-Feel | 0206 | Hornophon | 0213 |
| ALBIRAL | 0212 | Century | 0205 | Euroline | 0217 | Hoshai | 0209, 0218 |
| Allstar | 0213 | CGE | 0214, 0215 | Euroman | 0200 | Huanyu | 0200, 0207 |
| Amplivision | 0207 | Cimline | 0208, 0218 | Euromann | 0206, 0207, 0213 | Hygashi | 0200, 0207 |
| Amstrad | 0204, 0206, 0208, 0209, 0218 | Citizen | 0060, 0061, 0062, 0064 | Europhon | 0200, 0204, 0207, 0213, 0215 | Hyper | 0200, 0207, 0208, 0214, 0215 |
| Amtron | 0062 | City | 0208 | Fenner | 0208 | Hypson | 0206, 0207, 0213, 0217 |
| Anam | 0208 | Clarivox | 0212, 0217 | Ferguson | 0212, 0217, 0226 | ICE | 0127, 0200, 0206, 0207, 0208, 0209, 0213, 0218 |
| Anam National | 0062 | Clatronic | 0206, 0207, 0208, 0209, 0213, 0214, 0218 | Fidelity | 0200, 0207, 0210 | ICeS | 0200, 0218 |
| Anglo | 0208 | CMS | 0200 | Finlandia | 0210 | IMA | 0062 |
| Anitech | 0206, 0208 | Colorlyme | 0060, 0061 | Finlux | 0204, 0205, 0207, 0213, 0215, 0217 | Imperial | 0211, 0213, 0214, 0215 |
| Ansonic | 0203, 0208 | Concerto | 0060, 0061 | Firstline | 0200, 0207, 0208, 0213, 0214 | Indiana | 0213, 0217 |
| AOC | 0060, 0061 | Concorde | 0208 | Fisher | 0064, 0127, 0128, 0205, 0207, 0215 | Infinity | 0063 |
| Apex | 0118, 0122, 0132 | Condor | 0200, 0207, 0213 | Flint | 0213, 0218 | Ingelen | 0211 |
| Arc en Ciel | 0216 | Contec | 0200, 0207, 0208 | Formenti | 0200, 0205, 0207, 0215, 0217 | Ingersol | 0208 |
| Arcam | 0200 | Contec/Cony | 0062 | Formenti-Phoenix | | Inno Hit | 0201, 0204, 0207, 0208, 0209, 0213, 0217, 0218 |
| Arcam Delta | 0207 | Continental Edison | | | | Innovation | 0206, 0208 |
| Aristona | 0213, 0217 | | 0216 | | | Interbuy | 0208, 0214 |
| ASA | 0205, 0211 | Cosmel | 0208 | | | Interfunk | 0205, 0211, 0213, 0214, 0216, 0217 |
| Asberg | 0213 | Craig | 0062 | | | International | 0200 |
| Astra | 0208 | Crosley | 0205, 0214, 0215 | | | Intervision | 0206, 0207, 0218 |
| Asuka | 0200, 0206, 0207, 0209, 0218 | Crown | 0062, 0063, 0128, 0208, 0213, 0217 | | | Irradio | 0201, 0208, 0209, 0213, 0217, 0218 |
| Atlantic | 0200, 0207, 0213, 0217 | Crown | 0062, 0063, 0128, 0208, 0213, 0217 | | | Isukai | 0209, 0218 |
| Atori | 0208 | CS Electronics | 0200, 0207, 0209, 0214, 0218 | | | ITC | 0207, 0215 |
| Audiosonic | 0207, 0208, 0209, 0213, 0216, 0217, 0218 | CTC | 0214 | | | ITS | 0200, 0209, 0213, 0218 |
| AudioTon | 0207 | Curtis Mathes | 0057, 0060, 0061, 0064, 0065 | | | ITT | 0129, 0208, 0211 |
| Audiovox | 0062 | CXC | 0062 | | | ITV | 0208, 0217 |
| Autovox | 0205, 0206, 0207 | Cybertron | 0209, 0218 | | | JBL | 0063 |
| Awa | 0200 | Daewoo | 0060, 0061, 0120, 0127, 0155, 0193, 0200, 0207, 0208, 0213, 0218, 0238 | | | JC Penney | 0057, 0060, 0061 |
| Baird | 0216 | Dainichi | 0200, 0209, 0218 | | | JCB | 0059 |
| Bang & Olufsen | 0205 | Dansai | 0200, 0206, 0213, 0217 | | | Jensen | 0060, 0061 |
| Basic Line | 0208, 0209, 0213, 0218 | Dantax | 0217 | | | JVC | 0017, 0018, 0019, 0108, 0136, 0153, 0178, 0190, 0213, 0218 |
| Bastide | 0207 | Daytron | 0060, 0061, 0208 | | | Kaisui | 0200, 0207, 0208, 0209, 0218 |
| Baur | 0217 | De Graaf | 0210 | | | Kamosonic | 0207 |
| Beko | 0228 | Decca | 0204, 0207, 0213, 0217 | | | Kamp | 0200, 0207 |
| Belcor | 0060 | Desmet | 0213, 0217 | | | Kapsch | 0211 |
| Bell & Howell | 0058, 0064 | Diamond | 0200 | | | Karcher | 0207, 0208, 0212, 0217 |
| Benq | 0081 | Dimensia | 0057 | | | Kawasho | 0059, 0060, 0061, 0200 |
| Beon | 0213, 0217 | Dixi | 0208, 0213, 0217 | | | Kendo | 0128, 0210 |
| Bestar | 0213 | DTS | 0208 | | | Kennedy | 0215 |
| Binatone | 0207 | Dual | 0207, 0215, 0216 | | | Kenwood | 0060, 0061 |
| Black Star | 0214 | Dual-Tec | 0207, 0208, 0215 | | | Kingsley | 0200, 0207 |
| Blaupunkt | 0255 | Dumont | 0060, 0127, 0205, 0207 | | | Kloss Novabeam | |
| Blue Sky | 0209, 0218 | Durabrand | 0126 | | | | 0062 |
| Bondstec | 0214 | Dux | 0217 | | | Kneissel | 0203 |
| Boots | 0207 | Dynatron | 0213, 0217 | | | Kolster | 0213 |
| Bradford | 0062 | Elbe | 0203, 0204, 0212, 0218 | | | Konka | 0209, 0218 |
| Brandt | 0216, 0226 | Elbe-Sharp | 0204 | | | Korpel | 0213, 0217 |
| Brionvega | 0205, 0213, 0217 | Elicit | 0204, 0205 | | | Korting | 0205 |
| Britannia | 0200, 0207 | ELECTRO TECH | | | | Koyoda | 0208 |
| Brockwood | 0060 | | 0208 | | | KTV | 0062, 0127, 0207 |
| Broksonic | 0138 | | 0059 | | | Kyoto | 0200, 0212 |
| Bruns | 0205 | Electroband | 0059, 0060, 0061 | | | | |
| BSR | 0215 | Electrohome | 0200, 0207, 0213, 0217 | | | | |
| BTC | 0209, 0218 | Elin | 0200, 0207, 0213, 0217 | | | | |
| Bush | 0177, 0208, 0209, 0210, 0213, 0215, 0216, 0217, 0218, 0230, 0237 | Elite | 0209, 0213, 0218 | | | | |
| Candle | 0060, 0061 | Elman | 0215 | | | | |
| Capsonic | 0206 | Elta | 0200, 0208 | | | | |
| | | Emerson | 0060, 0061, 0062, 0064, 0128, 0205 | | | | |

| | | | | | | | |
|-----------------|-------------------|------------------|-------------------|-----------------------|-------------------|-------------------|-------------------|
| Lenco | 0208 | NEC | 0026, 0053, 0060, | 0182, 0194, 0195, | Sanyo | 0020, 0021, 0022, | |
| Lenoir | 0207, 0208 | | 0061, 0096, 0127 | 0211, 0213, 0216, | | 0049, 0060, 0064, | |
| Lesa | 0214 | Neckermann | 0205, 0207, 0210, | 0217, 0250 | | 0127, 0128, 0200, | |
| Leyco | 0206, 0213, 0217 | | 0213, 0217, 0255 | 0206, 0213 | | 0203, 0207, 0215 | |
| LG | 0016, 0038, 0039, | NEI | 0213, 0217 | Plantron | | | |
| | 0127, 0128, 0157, | Nesco | 0214 | Polaroid | 0075 | SBR | 0217 |
| | 0158, 0163, 0164, | NET-TV | 0082, 0101 | Poppy | 0208 | SCHAUB LORENTZ | 0211 |
| | 0166, 0188, 0189, | New Tech | 0208, 0213 | Portland | 0060, 0061 | | |
| | 0200, 0201, 0207, | New World | 0209, 0218 | Prandoni-Prince | 0204, 0210 | Schneider | 0207, 0209, 0213, |
| | 0208, 0210, 0213, | Nicamagic | 0200, 0207 | Precision | 0207 | | 0215, 0216, 0217, |
| | 0214, 0215, 0217 | Nikkai | 0200, 0206, 0207, | Prima | 0208, 0211 | | 0218 |
| Liesenk | 0217 | | 0209, 0213, 0217, | Profex | 0208 | Scotch | 0061 |
| Life | 0206, 0208 | | 0218 | Profi-Tronic | 0213 | Scott | 0060, 0061, 0062 |
| Lifetec | 0206, 0208, 0218 | Nikko | 0061 | Proline | 0213 | Sears | 0057, 0060, 0061, |
| Loewe | 0063, 0128, 0203, | Nobliko | 0200, 0207 | Proscan | 0057 | | 0064 |
| | 0204, 0223, 0227 | Nogamatic | 0216 | Prosonic | 0200, 0207, 0217 | SEG | 0200, 0206, 0207, |
| Loewe Opta | 0205, 0213, 0217 | Nokia | 0129, 0211 | Protech | 0206, 0207, 0208, | | 0214, 0215, 0217 |
| Logik | 0058 | Nordmende | 0205, 0211, 0213, | | 0213, 0214, 0215, | SEI | 0204 |
| Luma | 0210, 0217 | | 0216 | Proton | 0060, 0061 | SEI-Sinudyne | 0204, 0205, 0211 |
| Lumatron | 0210, 0213, 0217 | Nordvision | 0217 | Provision | 0217 | Seleco | 0210, 0211, 0215 |
| Lux May | 0213 | Oceanic | 0211 | Pulsar | 0060 | Sencora | 0208 |
| Luxman | 0060, 0061 | Olevia | 0084 | Pye | 0213, 0217 | Sentra | 0218 |
| Luxor | 0201, 0207, 0210 | ONCEAS | 0207 | Pymi | 0208 | Serino | 0200 |
| LXI | 0057, 0061, 0063, | Onwa | 0062, 0218 | Quasar | 0152, 0214 | Sharp | 0009, 0010, 0011, |
| | 0064 | Orbit | 0213 | Quelle | 0201, 0206, 0207, | | 0060, 0061, 0066, |
| Magnadyne | 0204, 0205, 0214, | Orion | 0126, 0204, 0208, | | 0213, 0214, 0215, | | 0070, 0087, 0111, |
| | 0215, 0217 | | 0213, 0217, 0235 | | 0217 | | 0143, 0145, 0167, |
| Magnafon | 0200, 0204, 0207 | Orline | 0218 | Radialva | 0218 | | 0168, 0169, 0198, |
| Magnavox | 0060, 0061, 0063, | Orsowe | 0204 | Radio Shack | 0064 | | 0204, 0224, 0247, |
| | 0102, 0103, 0150 | Osaki | 0127, 0206, 0207, | Radio Shack/Realistic | | Shogun | 0248, 0249 |
| | 0206, 0208 | | 0209, 0218 | | 0057, 0060, 0061, | | 0060 |
| Magnum | 0206, 0208 | Osio | 0201 | | 0062, 0064 | Siarem | 0204, 0205, 0215 |
| Majestic | 0058 | Oso | 0209, 0218 | Radiola | 0213, 0217 | Sicatel | 0212 |
| Mandor | 0206 | Osume | 0218 | Radiomarelli | 0204, 0205, 0214 | Siemens | 0255 |
| Manesth | 0206, 0207, 0213, | Otto Versand | 0204, 0207, 0213, | Radiotone | 0213 | Sierra | 0213 |
| | 0217 | | 0215, 0216, 0217, | RCA | 0057, 0060, 0061, | Signature | 0058 |
| Marantz | 0060, 0061, 0063, | | 0255 | | 0091, 0133, 0135, | Silva | 0200 |
| | 0090, 0213, 0217 | Pael | 0200, 0207 | | 0147, 0149 | Singer | 0205, 0214, 0215 |
| Marelli | 0205 | Palladium | 0207 | Realistic | 0064 | Sinudyne | 0204, 0205, 0215, |
| Mark | 0200, 0213, 0217 | Panama | 0200, 0206, 0207, | | 0213, 0217 | | 0217 |
| Matsui | 0204, 0207, 0208, | | 0208 | Revox | 0213, 0217 | Skantic | 0211 |
| | 0210, 0213, 0217 | Panasonic | 0006, 0007, 0063, | Rex | 0206, 0210, 0211 | Solavox | 0211 |
| Mediator | 0213, 0217 | | 0073, 0074, 0097, | RFT | 0203, 0205 | Sonoko | 0206, 0207, 0208, |
| Medion | 0206, 0208 | | 0110, 0114, 0137, | Rhapsody | 0200 | | 0213, 0217 |
| Megatron | 0061 | | 0141, 0151, 0162, | R-Line | 0213, 0217 | Sonolor | 0211 |
| Melectronic | 0200, 0207, 0208, | | 0165, 0186, 0204, | Roadstar | 0206, 0208, 0209, | Sontec | 0213, 0217 |
| | 0211, 0213, 0216, | | 0211, 0244, 0245, | | 0218, 0237 | Sony | 0041, 0059, 0067, |
| | 0217 | | 0246, 0254 | Robotron | 0205 | | 0085, 0086, 0174, |
| Memorex | 0058, 0061, 0064, | Pathe Cinema | 0200, 0203, 0207, | Rowa | 0200 | | 0196, 0199, 0208, |
| | 0208 | | 0212, 0215 | RTF | 0205 | | 0219, 0234 |
| Memphis | 0208 | | 0212, 0215 | Saba | 0204, 0205, 0211, | Sound & Vision | 0209, 0218 |
| Metz | 0205 | Pathe Marconi | 0212, 0216 | | 0216 | Soundesign | 0060, 0061, 0062 |
| MGA | 0060, 0061 | Pausa | 0208 | saccs | 0212 | Soundwave | 0213, 0217 |
| Micromaxx | 0206, 0208 | Perdio | 0200 | Saisho | 0204, 0206, 0207, | SSS | 0060, 0062 |
| Microstar | 0206, 0208 | Philco | 0060, 0061, 0063, | | 0208 | Standard | 0207, 0208, 0209, |
| Minerva | 0204 | | 0128, 0205, 0214, | Salora | 0201, 0204, 0210, | | 0213, 0218 |
| Minoka | 0213 | | 0215 | | 0211, 0215 | Starlight | 0217 |
| Mitsubishi | 0006, 0015, 0016, | Philharmonic | 0207 | Sambers | 0204 | Starlite | 0062 |
| | 0048, 0060, 0061, | Philips | 0040, 0060, 0063, | Sampo | 0060, 0061, 0083, | Stenway | 0218 |
| | 0104, 0112, 0113, | | 0072, 0115, 0116, | | 0101 | Stern | 0210, 0211 |
| | 0125, 0205, 0213 | | 0124, 0130, 0150, | Samsung | 0029, 0030, 0031, | Sunkai | 0208, 0218 |
| Mivar | 0200, 0201, 0202, | | 0175, 0184, 0187, | | 0032, 0044, 0045, | Sunwood | 0208, 0213 |
| | 0203, 0204, 0207 | | 0205, 0207, 0213, | | 0046, 0047, 0060, | Superla | 0200, 0204, 0207 |
| Montgomery Ward | | | 0215, 0217, 0220, | | 0061, 0065, 0068, | SuperTech | 0200 |
| | 0058 | | 0221, 0232, 0233, | | 0069, 0071, 0079, | Supra | 0208 |
| MTC | 0060, 0061, 0128, | | 0252, 0253 | | 0087, 0127, 0128, | Supreme | 0059 |
| | 0200 | Philips Magnavox | | | 0130, 0144, 0160, | Susumu | 0209 |
| Multi System | 0217 | | 0124 | | 0161, 0170, 0176, | Sutron | 0208 |
| Multitech | 0062, 0127, 0128, | Phoenix | 0200, 0205, 0213, | | 0183, 0185, 0200, | Sydney | 0200, 0207 |
| | 0200, 0207, 0208, | | 0217 | | 0201, 0206, 0207, | Sylvania | 0060, 0061, 0063, |
| | 0210, 0214, 0215, | Phonola | 0200, 0205, 0213, | | 0208, 0213, 0217, | | 0080, 0134, 0142, |
| | 0217 | | 0217 | | 0239, 0241, 0242, | | 0148 |
| Murphy | 0200, 0207 | Pilot | 0060 | | 0243 | Symphonic | 0062, 0080 |
| NAD | 0061 | Pioneer | 0012, 0013, 0060, | Sandra | 0200, 0207 | Sysline | 0217 |
| Naonis | 0210 | | 0061, 0098, 0109, | Sansui | 0123, 0126, 0213 | Sytong | 0200 |
| | | | 0117, 0128, 0181, | | | | |

| | | | | | | | |
|--------------|--|--------------------|--|------------------|------------------------------|------------------------|--|
| Tandy | 0127, 0207, 0209, 0211, 0218 | Weltblick | 0213, 0217 | Alba | 1044, 1050 | GoldHand | 1050 |
| Tashiko | 0200, 0207, 0210 | Weston | 0215 | American High | 1004 | Goldstar | 1000, 1003, 1042, 1045 |
| Tatung | 0127, 0204, 0207, 0213, 0217, 0237 | White Westinghouse | 0200, 0207, 0217 | Amstrad | 1042 | Goodmans | 1042, 1045, 1050, 1069 |
| TCM | 0206, 0208 | Yamaha | 0000, 0001, 0002, 0003, 0004, 0005, 0060, 0061 | Anitech | 1050 | Gradiente | 1005 |
| Teac | 0127 | Yamishi | 0218 | ASA | 1045, 1046 | Graetz | 1043, 1047 |
| Tec | 0207, 0208, 0214, 0215 | Yoko | 0200, 0206, 0207, 0208, 0209, 0213, 0217, 0218 | Asha | 1002, 1014 | Granada | 1046, 1047, 1049 |
| Techwood | 0060, 0061 | Yorx | 0209, 0218 | Asuka | 1042, 1045, 1046, 1050 | Grandin | 1042, 1045, 1050 |
| Teknika | 0058, 0060, 0061, 0062 | Zanussi | 0210 | Audio Dynamics | 1000 | Grundig | 1046, 1050, 1062 |
| Teleavia | 0216 | Zenith | 0058, 0060, 0100, 0105, 0119, 0121, 0154 | Baird | 1042, 1043, 1047 | Hanseatic | 1045, 1046 |
| Telecor | 0218 | | | Basic Line | 1044, 1050 | Harley Davidson | 1005 |
| Telefunken | 0065, 0213, 0216 | | | Baur | 1046 | Harman/Kardon | 1000 |
| Telegazi | 0218 | | | Beaumarck | 1002, 1014 | Harwood | 1006 |
| Teletech | 0208, 0214, 0217 | | | Bell & Howell | 1001 | HCM | 1050 |
| Teleton | 0207 | | | Blaupunkt | 1046, 1048 | Headquarter | 1001 |
| Televideon | 0200 | | | Broksonic | 1012, 1013 | Hinari | 1044, 1050 |
| Tensai | 0208, 0209, 0213, 0218 | | | Bush | 1044, 1050, 1066 | Hisawa | 1044 |
| Tesmet | 0213 | | | Calix | 1003 | Hitachi | 1007, 1010, 1039, 1042, 1043, 1046, 1049 |
| Tevision | 0206, 0208 | | | Candle | 1002, 1003 | | |
| Texet | 0200, 0207 | | | Canon | 1004 | Hughes Network Systems | 1010 |
| Thomson | 0191, 0192, 0207, 0213, 0216, 0226 | | | CCE | 1006 | Hypson | 1044, 1050 |
| Thorn | 0212, 0217 | | | CGE | 1042, 1043 | Imperial | 1042 |
| TMK | 0060, 0061 | | | Cimline | 1044, 1050 | Inno Hit | 1046, 1050 |
| Tokai | 0213 | | | Citizen | 1002, 1003 | Innovation | 1044, 1048 |
| Tokyo | 0200, 0207 | | | Colortyme | 1000 | Instant Replay | 1004 |
| Toshiba | 0027, 0043, 0053, 0054, 0064, 0078, 0089, 0090, 0106, 0107, 0127, 0131, 0140, 0146, 0159, 0197, 0225, 0231, 0237 | | | Colt | 1006 | Interbuy | 1045 |
| Towada | 0211, 0215 | | | Craig | 1002, 1003, 1006, 1014 | Interfunk | 1046, 1047 |
| Transtec | 0200 | | | Crown | 1050 | Intervision | 1042 |
| Trident | 0204 | | | Curtis Mathes | 1000, 1002, 1004, 1009 | Irradio | 1045, 1050 |
| Tristar | 0218 | | | Cybernex | 1002, 1014 | ITT | 1043, 1047 |
| Triumph | 0204 | | | Daewoo | 1005, 1038, 1061, 1067 | ITV | 1045 |
| Uher | 0211, 0213 | | | Dansai | 1050 | JC Penney | 1000, 1001, 1002, 1003, 1004, 1006 |
| Ultravox | 0200, 0205, 0207, 0214, 0215 | | | Dantax | 1044 | JCL | 1004 |
| United | 0217 | | | DBX | 1000 | Jensen | 1007 |
| Universum | 0127, 0128, 0129, 0201, 0206, 0213, 0214, 0215, 0217 | | | De Graaf | 1046, 1049 | JVC | 1000, 1001, 1007, 1011, 1017, 1036, 1043 |
| Univox | 0212 | | | Decca | 1042, 1043, 1046 | | |
| Vestel | 0210, 0211, 0213, 0214, 0215, 0217 | | | Denon | 1010 | Kaisui | 1050 |
| Vexa | 0208, 0217 | | | Dimensia | 1009 | Karcher | 1046 |
| Victor | 0213 | | | Dual | 1043, 1046 | Kendo | 1044 |
| VIDEOLOGIC | 0200 | | | Dumont | 1042, 1046, 1047, 1049 | Kenwood | 1000, 1001, 1007, 1011, 1043 |
| Videologique | 0200, 0207, 0209, 0218 | | | Dynatech | 1005 | KLH | 1006 |
| Videosat | 0214 | | | Electrohome | 1003 | Kodak | 1003, 1004 |
| VideoSystem | 0213 | | | Electroponic | 1003 | Korpel | 1050 |
| Videotechnic | 0200 | | | Elta | 1050 | Leyco | 1050 |
| Vidtech | 0060, 0061 | | | Emerson | 1003, 1004, 1005, 1012, 1013 | LG | 1003, 1042, 1045, 1071 |
| Viewsonic | 0076, 0077, 0092, 0099, 0172, 0173 | | | Etzuko | 1050 | Lifetec | 1044, 1048 |
| Visiola | 0200, 0207 | | | Ferguson | 1043 | Lloyd's | 1005 |
| Vision | 0213 | | | Fidelity | 1042 | Loewe | 1048 |
| Vortec | 0213, 0217 | | | Finlandia | 1046, 1047, 1049 | Loewe Opta | 1045, 1046 |
| Voxson | 0205, 0210, 0211, 0213 | | | Finlux | 1042, 1043, 1046, 1047, 1049 | Logik | 1006, 1050 |
| Waltham | 0207, 0212 | | | FIRST LINE | 1044, 1045, 1049, 1050 | Luxor | 1047 |
| Wards | 0057, 0058, 0060, 0061, 0063 | | | Fisher | 1001, 1047 | LXI | 1003 |
| Watson | 0213, 0217, 0218 | | | Flint | 1044 | M Electronic | 1042 |
| Watt Radio | 0200, 0207, 0212, 0215 | | | Formenti/Phoenix | 1046 | Magnasonic | 1047 |
| Wega | 0205 | | | Fuji | 1004 | Magnavox | 1004, 1018, 1033 |
| | | | | Fujitsu | 1042 | Magnin | 1003, 1014 |
| | | | | Funai | 1005, 1042 | Manesth | 1050 |
| | | | | Galaxy | 1042 | Marantz | 1000, 1001, 1004, 1046, 1051 |
| | | | | Garrard | 1005 | Marta | 1003 |
| | | | | GBC | 1050 | Matsui | 1044, 1045 |
| | | | | GE | 1002, 1004, 1009, 1014, 1030 | Matsushita | 1004 |
| | | | | GEC | 1046 | Mediator | 1046 |
| | | | | Geloso | 1050 | Medion | 1044, 1048 |
| | | | | General Technic | 1044, 1048 | MEI | 1004 |
| | | | | Go Video | 1014 | | |

TV/DVD

| | |
|-----------|------------------------|
| Aiwa | 0139, 2055 |
| Apex | 0132, 2049 |
| Broksonic | 0138, 2060 |
| Bush | 0230, 2112 |
| JVC | 0136, 2053 |
| Panasonic | 0137, 0254, 2054, 2110 |
| RCA | 0133, 0135, 2050, 2051 |
| Sylvania | 0134, 2052 |
| Thomson | 0226, 2109 |
| Toshiba | 0131, 0231, 2048, 2111 |

TV/DVD/VCR

| | |
|-----------|------------------|
| Panasonic | 0141, 1040, 2057 |
| Samsung | 0241, 1070, 2113 |
| Sharp | 0143, 1028, 2059 |
| Sylvania | 0142, 1041, 2058 |
| Toshiba | 0140, 1029, 2056 |

TV/VCR

| | |
|-----------|------------------------------------|
| Aiwa | 0237, 1066 |
| Bush | 0237, 1066 |
| Daewoo | 0155, 0238, 1038, 1067 |
| GE | 0147, 1030 |
| Goodmans | 0240, 1069 |
| Grundig | 0236, 1062 |
| Hitachi | 0156, 1039 |
| JVC | 0153, 1036 |
| Magnavox | 0150, 1033 |
| Orion | 0235, 1065 |
| Panasonic | 0151, 1034 |
| Philips | 0150, 0232, 0233, 1033, 1062, 1063 |
| Quasar | 0152, 1035 |
| RCA | 0149, 1032 |
| Roadstar | 0237, 1066 |
| Samsung | 0144, 0239, 1027, 1068 |
| Sharp | 0145, 1028 |
| Sony | 0234, 1064 |
| Sylvania | 0148, 1031 |
| Tatung | 0237, 1066 |
| Toshiba | 0146, 0237, 1029, 1066 |
| Zenith | 0154, 1037 |

VCR

| | |
|-----------|------------------------------|
| Admiral | 1008, 1013 |
| Adventura | 1005 |
| Aiwa | 1005, 1042, 1043, 1044, 1066 |
| Akai | 1007, 1043 |
| Akiba | 1050 |
| Akura | 1043, 1050 |

List of remote control codes

The following remote control codes are available in addition to “List of remote control codes” at the end of the owner’s manual.

VCR

| | | | | | | | |
|-----------------|--|-----------------------|--|----------------|--|--------------------|--|
| Memorex | 1001, 1002, 1003, 1004, 1005, 1008, 1013, 1014, 1042, 1045, 1047 | Panasonic | 1004, 1020, 1034, 1040, 1048, 1054, 1072 | Saisho | 1044, 1050 | Tashiko | 1003, 1042 |
| Memphis | 1050 | Pathe Marconi | 1043 | Salora | 1047 | Tatung | 1007, 1042, 1043, 1046, 1066 |
| Metz | 1048 | Penney | 1010, 1014 | Samsung | 1002, 1014, 1021, 1027, 1052, 1068, 1070 | TCM | 1044, 1048 |
| MGA | 1014 | Pentax | 1010, 1049 | Sanky | 1008 | Teac | 1005, 1007 |
| MGN Technology | | Perdio | 1042 | Sansui | 1007, 1011, 1013, 1043 | Technics | 1004, 1048 |
| | 1002, 1014 | Philco | 1004, 1051 | Sanyo | 1001, 1002, 1014, 1047 | Teknika | 1003, 1004, 1005 |
| Micromaxx | 1044, 1048 | Philips | 1004, 1025, 1033, 1046, 1056, 1057, 1059, 1062, 1063 | SBR | 1046 | Teleavia | 1043 |
| Microstar | 1044, 1048 | Philips Magnavox | | Schaub Lorenz | 1042, 1043, 1047 | Telefunken | 1043 |
| Migros | 1042 | | 1018 | Schneider | 1042, 1044, 1045, 1046, 1050 | Tenosal | 1050 |
| Minolta | 1010 | Phonola | 1046 | Scott | 1012 | Tensai | 1042, 1045, 1050 |
| Mitsubishi | 1011, 1042, 1046 | Pilot | 1003 | Sears | 1001, 1003, 1004, 1010 | Tevion | 1044, 1048 |
| Montgomery Ward | | Pioneer | 1011, 1046 | SEI-Sinudyne | 1046 | Thomson | 1043, 1058 |
| | 1008 | Prinz | 1042 | Seleco | 1043 | Thorn | 1043, 1047 |
| Motorola | 1004, 1008 | Profex | 1050 | Sentron | 1050 | TMK | 1002, 1014 |
| MTC | 1002, 1014 | Profitronic | 1014 | Sharp | 1008, 1023, 1028, 1053, 1073 | Tokai | 1045, 1050 |
| Multitech | 1002, 1005, 1006, 1042, 1046, 1050 | Proline | 1042 | Shintom | 1006, 1047, 1050 | Tonsai | 1050 |
| Murphy | 1042 | Proscan | 1009 | Shivaki | 1045 | Toshiba | 1013, 1024, 1029, 1043, 1046, 1066, 1075 |
| National | 1048 | Prosonic | 1044 | Shogun | 1002, 1014 | Totevision | 1002, 1003, 1014 |
| NEC | 1000, 1001, 1007, 1011, 1043, 1051 | Protex | 1006 | Siemens | 1045, 1047 | Towada | 1050 |
| Neckermann | 1043, 1046 | Pye | 1046, 1056 | Signature 2000 | 1008 | Towika | 1050 |
| NEI | 1046 | Quarter | 1001 | Silva | 1045 | Uher | 1045 |
| Nesco | 1050 | Quartz | 1001, 1047 | Singer | 1004, 1006 | Unitech | 1002, 1014 |
| Nikko | 1003 | Quasar | 1004, 1035 | Sinudyne | 1046 | Universum | 1042, 1045, 1046 |
| Noblex | 1002, 1014 | Quelle | 1042, 1046, 1047 | Sontec | 1045 | Vector Research | 1000 |
| Nokia | 1043, 1047 | Radio Shack | 1003 | Sony | 1016, 1019, 1055, 1060, 1064, 1074 | Video Concepts | 1000 |
| Nordmende | 1043 | Radio Shack/Realistic | 1001, 1002, 1003, 1004, 1005, 1008 | STS | 1004, 1010 | Videon | 1044, 1048 |
| Oceanic | 1042, 1043 | Radiola | 1046 | Sunkai | 1044 | Videosonic | 1002, 1014 |
| Okano | 1044 | Radix | 1003 | Sunstar | 1042 | Wards | 1002, 1003, 1004, 1005, 1006, 1008, 1010, 1014 |
| Olympus | 1004 | Randex | 1003 | Suntronic | 1042 | Weltblick | 1045 |
| Optimus | 1003, 1008 | RCA | 1002, 1004, 1009, 1010, 1014, 1015, 1022, 1032 | Sunwood | 1050 | White Westinghouse | 1013 |
| Orion | 1012, 1013, 1044, 1065 | Realistic | 1001, 1002, 1003, 1004, 1005, 1008 | Sylvania | 1004, 1005, 1031, 1041 | XR-1000 | 1004, 1005, 1006 |
| Orson | 1042 | Rex | 1043 | Symphonic | 1005 | Yamaha | 1000, 1001, 1007 |
| Osaki | 1042, 1045, 1050 | RFT | 1046 | Taisho | 1044 | Yamishi | 1050 |
| Otto Versand | 1046 | Roadstar | 1045, 1050, 1066 | Tandy | 1001 | Yokan | 1050 |
| Palladium | 1043, 1045, 1050 | Saba | 1043 | | | Yoko | 1045, 1050 |
| | | | | | | Zenith | 1013, 1026, 1037 |



© 2009 Yamaha Corporation All rights reserved.

YAMAHA CORPORATION
Printed in China © WQ95900