

BLU-RAY DISC PLAYER

BD-A1010

OWNER'S MANUAL
MANUAL DE INSTRUCCIONES
사용 설명서

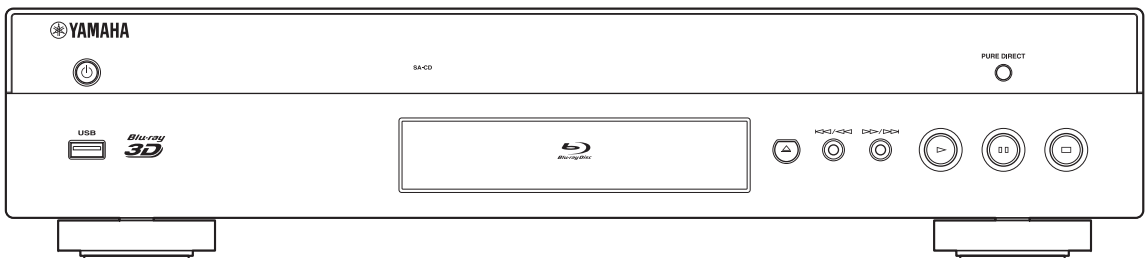

CAUTION: READ THIS BEFORE OPERATING YOUR UNIT.

- 1 To assure the finest performance, please read this manual carefully. Keep it in a safe place for future reference.
- 2 Install this unit in a well ventilated, cool, dry, clean place – away from direct sunlight, heat sources, vibration, dust, moisture, and/or cold. For proper ventilation, allow the following minimum clearances.
Top: 10 cm (4 in)
Rear: 10 cm (4 in)
Sides: 10 cm (4 in)
- 3 Locate this unit away from other electrical appliances, motors, or transformers to avoid humming sounds.
- 4 Do not expose this unit to sudden temperature changes from cold to hot, and do not locate this unit in an environment with high humidity (i.e. a room with a humidifier) to prevent condensation inside this unit, which may cause an electrical shock, fire, damage to this unit, and/or personal injury.
- 5 Avoid installing this unit where foreign object may fall onto this unit and/or this unit may be exposed to liquid dripping or splashing. On the top of this unit, do not place:
 - Other components, as they may cause damage and/or discoloration on the surface of this unit.
 - Burning objects (i.e. candles), as they may cause fire, damage to this unit, and/or personal injury.
 - Containers with liquid in them, as they may fall and liquid may cause electrical shock to the user and/or damage to this unit.
- 6 Do not cover this unit with a newspaper, tablecloth, curtain, etc. in order not to obstruct heat radiation. If the temperature inside this unit rises, it may cause fire, damage to this unit, and/or personal injury.
- 7 Do not plug in this unit to a wall outlet until all connections are complete.
- 8 Do not operate this unit upside-down. It may overheat, possibly causing damage.
- 9 Do not use force on switches, knobs and/or cords.
- 10 When disconnecting the power cable from the wall outlet, grasp the plug; do not pull the cable.
- 11 Do not clean this unit with chemical solvents; this might damage the finish. Use a clean, dry cloth.
- 12 Only voltage specified on this unit must be used. Using this unit with a higher voltage than specified is dangerous and may cause fire, damage to this unit, and/or personal injury. Yamaha will not be held responsible for any damage resulting from use of this unit with a voltage other than specified.
- 13 To prevent damage by lightning, keep the power cable disconnected from a wall outlet or this unit during a lightning storm.
- 14 Do not attempt to modify or fix this unit. Contact qualified Yamaha service personnel when any service is needed. The cabinet should never be opened for any reasons.
- 15 When not planning to use this unit for long periods of time (i.e. vacation), disconnect the AC power plug from the wall outlet.
- 16 Be sure to read the “TROUBLESHOOTING” section on common operating errors before concluding that this unit is faulty.

- 17 Before moving this unit, press  to set this unit to the standby mode, and disconnect the AC power plug from the wall outlet.
- 18 Condensation will form when the surrounding temperature changes suddenly. Disconnect the power cable from the outlet, then leave this unit alone.
- 19 When using this unit for a long time, this unit may become warm. Turn the power off, then leave this unit alone for cooling.
- 20 Install this unit near the AC outlet and where the AC power plug can be reached easily.
- 21 The batteries shall not be exposed to excessive heat such as sunshine, fire or the like.

This unit is not disconnected from the AC power source as long as it is connected to the wall outlet, even if this unit itself is turned off by . This state is called the standby mode. In this state, this unit is designed to consume a very small quantity of power.

WARNING

TO REDUCE THE RISK OF FIRE OR ELECTRIC SHOCK, DO NOT EXPOSE THIS UNIT TO RAIN OR MOISTURE.

The laser component in this product is capable of emitting radiation exceeding the limit for Class 1.

CAUTION

Use of controls or adjustments or performance of procedures other than those specified herein may result in hazardous radiation exposure.

LASER Specification:

Class 1 LASER Product

Wave length: 790 nm (CDs)/655 nm (DVDs)/405 nm (BDs)

Laser output: max. 1 mW

LASER SAFETY

This unit employs a laser. Due to possible eye injury, only a qualified service person should remove the cover or attempt to service this device.

DANGER

This unit emits visible laser radiation when open. Avoid direct eye exposure to beam. When this unit is plugged into the wall outlet, do not place your eyes close to the opening of the disc tray and other openings to look into inside.

CONTENTS

1

1. INTRODUCTION

WHAT YOU CAN DO WITH THIS PLAYER.....	2
SUPPLIED PARTS	2
ABOUT DISCS AND FILES.....	3
Types of discs/files that can be used with this Player	3
Loading a disc.....	4
Disc precautions	4
CONTROLS AND FUNCTIONS	5
Front panel	5
Remote control	6

2. CONNECTION

INTRODUCTION TO CONNECTIONS	10
Rear panel	10
HDMI CONNECTION	12
Connecting to the HDMI terminal.....	12
Connection for the playback of Blu-ray 3D discs	12
VIDEO CONNECTIONS	13
Connecting to the component/video jack	13
AUDIO CONNECTIONS	14
Connecting to the digital audio jack/terminal.....	14
Connecting to the audio jacks.....	15
NETWORK AND USB CONNECTION	16
Connecting to the NETWORK terminal and USB port....	16
OTHER CONNECTIONS	17
Connecting to the REMOTE CONTROL jacks	17
Connecting the power cable	17

3. PLAYBACK

INITIAL WIZARD/EASY SETUP.....	18
Setting with the Initial Wizard/Easy Setup.....	18
HOME/MEDIA MENU	19
Playing back photo/music/video.....	19
Using network content.....	21
USING NETWORK SERVICES	22
PLAYING VIDEOS FROM YouTube™	22
ADVANCED PLAYBACK OPERATION.....	23
On Screen menu.....	23
Status menu.....	24
Using Bookmark.....	25
Program play.....	25
Using search	25
Enjoying BONUSVIEW™ and BD-Live™.....	26
Using Picture in Picture function (secondary audio/video playback)	26
Using the feature of BD-Live™	26

4. SETTINGS

SETUP MENU.....	27
Example of SETUP menu operation	29
General Setting	30
Display Setting	32
Audio Setting	34
System Information	34
About the audio output formats	35
About the video output formats	36
SOFTWARE UPGRADE.....	37
Upgrading the software	37

5. ADDITIONAL INFORMATION

TROUBLESHOOTING	38
Power	38
Basic operation.....	38
Disc playback.....	38
Picture	39
Sound	39
Network.....	40
Messages on the screen.....	40
GLOSSARY	41
SPECIFICATIONS	42
General	42
Audio performance	42
Input/output	42
Copyright	43

(at the end of this manual)

Information about software	i
----------------------------------	---

2

3

4

5

■ About this manual

- This manual describes how to operate this Player using a remote control except when it is not available. Some of these operations are also available using the front panel buttons.
- Notes contain important information about safety and operating instructions. Hint(s) indicates a tip for your operation.
- This manual is printed prior to production. Design and specifications are subject to change in part as a result of improvements, etc. In case of differences between the manual and the product, the product has priority.

The icons used in this manual

Icons are used to indicate available buttons/functions for a particular format.

BD	: BD-Video
DVD	: DVD-Video, DVD-VR, DVD+VR, DVD-Audio
CD	: Audio CD, Super Audio CD
VIDEO	: AVCHD, WMV, DivX
MUSIC	: MP3, WMA, WAV
PHOTO	: JPEG

English

WHAT YOU CAN DO WITH THIS PLAYER

Easy setting for language, resolution, screen aspect ratio → p. 18

You can perform language and TV settings.

Play back commercially-released Blu-ray™/DVD/CD/SA-CD/DVD-Audio discs* → p. 23

In addition to Blu-ray Discs™ (BD discs), this Player also supports playback of a variety of other discs.

Play back BONUSVIEW™, BD-Live™, etc.* → p. 26

You can enjoy additional movies on the latest BD discs.

Play back Video, Music, Photo files on a disc* → p. 19

This Player can play back discs you recorded.

Play back Video, Music, Photo files on a disc/USB memory device* → p. 19

Files recorded on discs/USB memory devices can be played back with this Player.

Play back Video, Music, Photo files on a Home Network Server* ** → p. 21

PC contents can be played back with TV or AV receiver by connecting this Player to a network server.

Operation with the remote control of TV, AV receiver, etc. → p. 30

Connecting devices with an HDMI cable, you can control devices with a single remote control using the HDMI Control function.

Streaming Playback contents on the Network Services** → p. 22

You can instantly enjoy videos over the internet with this Player.

* For details on playable disc and format, see page 3.

** Network setting is needed to use this function.

SUPPLIED PARTS

Make sure the following accessories are provided with the product.

Remote control



Batteries (x2)
(AAA, R03, UM-4)

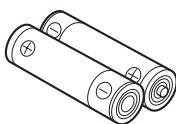

Audio pin cable

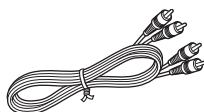

Video pin cable

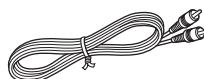



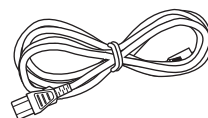







Power cable









Types of discs/files that can be used with this Player

- 12 cm (5") and 8 cm (3") discs can be played back in this Player. Do not use an 8 cm (3") to 12 cm (5") adapter.
- Use discs that conform to compatible standards as indicated by the presence of official logos on the disc label. Playback of discs not complying with these standards is not guaranteed. In addition, the image quality or sound quality is not guaranteed even if the discs can be played back.

Disc Type	Recording Format	Data Format
BD-ROM/BD-R/ BD-RE	BD-Video	--
DVD-ROM	DVD-Video/DVD-Audio	--
DVD-R/DVD-R DL/ DVD-RW	DVD-Video/DVD-VR/AVCHD/Data Disc	DivX/WMV/MP3/ WAV/WMA/JPEG
DVD+R/DVD+R DL/DVD+RW	DVD-Video/ DVD+VR/AVCHD/ Data Disc	DivX/WMV/MP3/ WAV/WMA/JPEG
CD-ROM	CDDA/HDCD	--
CD-R/CD-RW	CDDA/Data Disc	DivX/WMV/MP3/ WAV/WMA/JPEG
SA-CD	SA-CD	--
USB	--	DivX/WMV/MP3/ WAV/WMA/JPEG
Network	--	WMV/MP3/WMA/ WAV/JPEG

Region management information		
Destination	BD-Video	DVD-Video
Korea	Region code "A" or "ALL" 	Region number "3" or "ALL" 
Central and South America	Region code "A" or "ALL" 	Region number "4" or "ALL" 
Europe	Region code "B" or "ALL" 	Region number "2" or "ALL" 
Australia	Region code "B" or "ALL" 	Region number "4" or "ALL" 
Russia	Region code "C" or "ALL" 	Region number "5" or "ALL" 

Region management information		
Destination	BD-Video	DVD-Video
U.S.A. and Canada	Region code "A" or "ALL" 	Region number "1" or "ALL" 
Asia	Region code "A" or "ALL" 	Region number "3" or "ALL" 
Taiwan	Region code "A" or "ALL" 	Region number "3" or "ALL" 

- BD/DVD Video players and discs have region codes, which dictate the regions in which a disc can be played.
- BD/DVD Video operations and functions may be different from the explanations in this manual and some operations may be prohibited due to disc manufacturer's settings.
- If a menu screen or operating instructions are displayed during playback of a disc, follow the operating procedure displayed.

Notes

- Playback for some of the discs in the left side column tables may not be possible depending on the disc.
- Finalize all recording media that is played back in this Player.
- "Finalize" refers to a recorder processing a recorded disc so that it will play in other players/recorders as well as this Player. Only finalized discs will play back in this Player. (This Player does not have a function to finalize discs.)
- Playback of all files on the disc, USB memory device and network is not guaranteed.

- A copyright protected file cannot be played back via USB memory device and network.

MP3/WMA/WAV audio file requirement

- Sampling frequency: within 32 - 48 kHz (MP3/WMA), LPCM 44.1 kHz/16 bit/Stereo (WAV)
- Bitrate: within 8 - 320 kbps (MP3), 32 - 192 kbps (WMA)

WMV file requirement

- WMV9, maximum resolution is 1,920 × 1,080.

About Super Audio CD (SA-CD)

- Audio format based upon the current CD standards but includes a greater amount of information that provides higher quality sound. There are three types of discs: single layer, dual layer and hybrid discs. The hybrid disc can be played on existing CD players as well as Super Audio CD players since it contains both standard audio CD and Super Audio CD information.

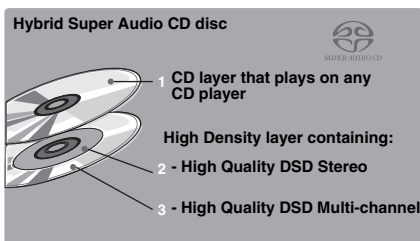
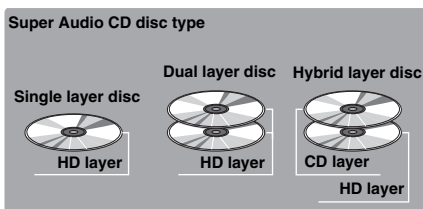

Hint

- This player supports DSD data transmission via HDMI using a compatible AV receiver.

Note

- This unit does not show the text data included in the discs on the front panel display.

Loading a disc

- Insert the disc with the label face up.
- In case of the disc recorded on both sides, face down the side to play back.

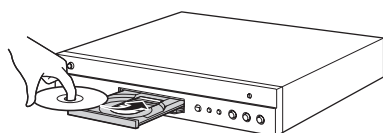

Notes

- Playback may begin automatically, depending on the disc and setting of this Player.
- The menu may be displayed first, depending on the disc.
- The disc load time may vary depending on the disc.

Disc precautions

Be careful of scratches and dust

- BD, DVD and CD discs are sensitive to dust, fingerprints and especially scratches. A scratched disc may not be able to be played back. Handle discs with care and store them in a safe place.

Proper disc storage

Place the disc in the center of the disc case and store the case and disc upright.	
Avoid storing discs in locations subject to direct sunlight, close to heating appliances or in locations of high humidity.	
Do not drop discs or subject them to strong vibrations or impacts.	
Avoid storing discs in locations where there are large amounts of dust or moisture.	

Handling precautions

- If the surface is soiled, wipe gently with a soft, damp (water only) cloth. When wiping discs, always move the cloth from the center hole toward the outer edge.
- Do not use record cleaning sprays, benzene, thinner, static electricity prevention liquids or any other solvent.
- Do not touch the surface.
- Do not stick paper or adhesive labels to the disc.
- If the playing surface of a disc is soiled or scratched, the Player may decide that the disc is incompatible and eject the disc tray, or it may fail to play the disc correctly. Wipe any dirt off the playing surface with a soft cloth.

Cleaning the pick up lens

- Never use commercially available cleaning discs. The use of these discs can damage the lens.
- Request the nearest service center approved by Yamaha to clean the lens.

■ Front panel

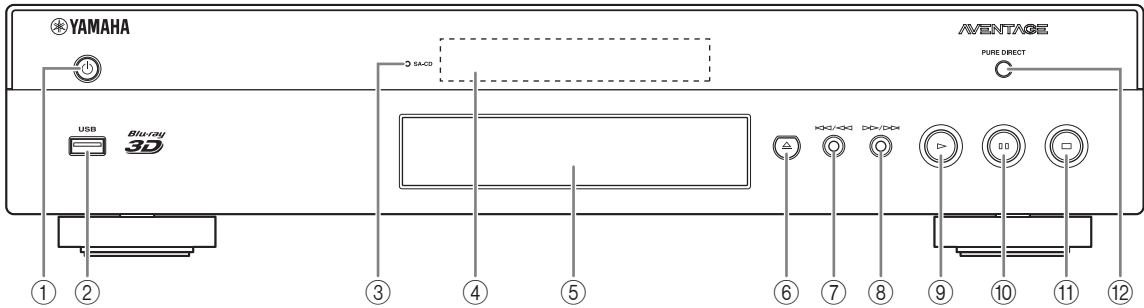

- ① **⏻ (On/Standby)**
- ② **USB port (p. 16)**
- ③ **SA-CD indicator:** Lights up when an SA-CD is loaded and the SA-CD layer (p. 4) is selected.
- ④ **Front panel display**
- ⑤ **Disc tray (p. 4)**
- ⑥ **▲ (Eject):** Opens/closes the disc tray.
- ⑦ **⏮/⏪ (Search backward/Skip backward):** Press to skip backward, and press and hold to search backward.
- ⑧ **⏩/⏭ (Search forward/Skip forward):** Press to skip forward, and press and hold to search forward.
- ⑨ **▶ (Play)**
- ⑩ **■ ■ (Pause)**
- ⑪ **■ (Stop)**
- ⑫ **PURE DIRECT:** Press to change the Pure Direct mode (p. 7) to mode 1/mode 2/off. This button lights up when Pure Direct mode is set to mode 1/mode 2.

Loading the batteries in the remote control

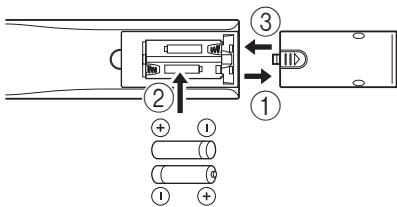

Notes

- Do not subject the remote control unit to shock, water or excessive humidity.
- The remote control unit may not function if the Player's remote sensor is in direct sunlight or any other strong light.
- Incorrect use of batteries may cause them to leak or burst. Read the battery warnings and use the batteries properly.
- Do not mix old and new batteries, or mix different brands.
- Remove the batteries if you will not use the remote control unit for an extended period of time.
- Dispose of batteries according to your regional regulations.

Approximate operating range of remote control

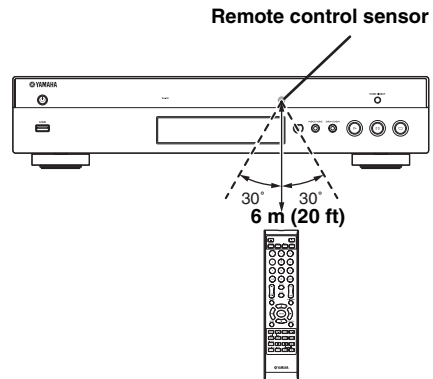



Remote control

Note

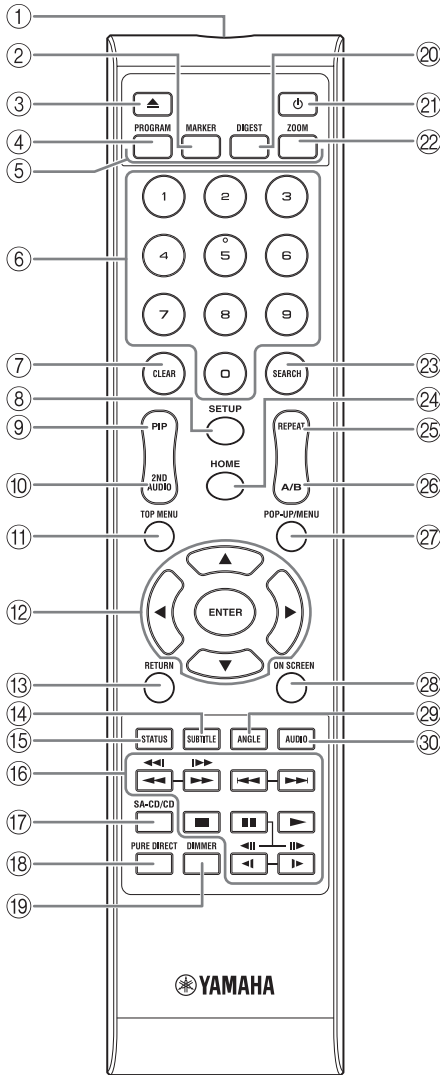
-  will appear on the top left corner of the screen when the pressed button is not available.



- ① **Infrared signal transmitter:** Outputs infrared signal. Aim this window to the remote control sensor (p. 5).
- ② **MARKER DVD VIDEO:** Sets Bookmark (p. 25) at a specified point of a movie. After Bookmark is set, to select the set point you want to jump to, press **DIGEST**. You can set up to 12 Bookmarks.
- ③ **▲:** Opens/closes the disc tray.
- ④ **PROGRAM DVD CD:** Sets the order of playback (p. 25). You can set up to 15 tracks (for an audio disc) or titles/chapters (DVD-Video).
- ⑤ **Color buttons BD:** Use these buttons according to on-screen instructions.
- ⑥ **Number buttons:** Enters numbers, or during playback, jumps to the track/chapter corresponding to the number you input. These buttons may not be available depending on the disc type and playback condition.
- ⑦ **CLEAR:** Clears entered number/set item.
- ⑧ **SETUP:** Displays SETUP menu screen (p. 27).
- ⑨ **PIP BD:** Turns on/off the Picture in Picture (p. 26). PIP Mark () is displayed on the screen when this function is available. You can also select this item from On Screen menu (p. 23).
- ⑩ **2ND AUDIO BD:** Selects the secondary audio of the Picture in Picture (p. 26) or audio commentaries. The Secondary Audio Mark () is displayed on the screen when this function is available (p. 34). You can also select this item from On Screen menu (p. 23).

Note

- PIP Mark is displayed only when the PIP Mark is set to on (p. 31).

Note

- Secondary Audio Mark is displayed only when Secondary Audio Mark is set to on (p. 31).

- ⑪ **TOP MENU** **BD** **DVD**: Displays the top menu screen (p. 42) if the disc contains a menu. Select the desired item using **▲/▼/◀/▶** and **ENTER**.

Note

– Specific operations may be different depending on the disc. Follow the instructions of each menu screen.

- ⑫ **Cursor buttons (▲/▼/◀/▶)**: Moves the focus in the menu screen.
ENTER: Selects the focused menu/item.
- ⑬ **RETURN**: Returns to the previous menu or screen, etc.
- ⑭ **SUBTITLE** **BD** **DVD** **VIDEO**: Changes subtitle languages (p. 42) if available. You can also select this item from On Screen menu (p. 23).
- ⑮ **STATUS**: Displays the playback information (p. 24).

⑯ **Control buttons****BD** **DVD** **CD** **VIDEO** **MUSIC** **PHOTO****BD** **DVD** **CD** **VIDEO** **MUSIC**:

Searches backward/forward. The search speed will change each time you press the button (search backward/forward: 5 steps each). Press **▶** to resume normal playback.

PHOTO: Changes the speed of a slide show (slower/faster: 3 steps).

◀◀/▶▶ **BD** **DVD** **CD** **VIDEO** **MUSIC**:

Press and hold for instant search/replay. Instant search skips the content 30 seconds. Instant replay replays the content from 10 seconds before.

◀◀/▶▶: Skips backward/forward.

■: Stops playback. To stop playback completely, press this button twice.

■: Pauses playback.

▶: Plays back contents.

◀ (**◀||**) / **▶** (**||▶**)

BD **DVD**: Performs slow backward/forward. Slow playback speed will change each time you press the button (slow backward/forward: 4 steps each). These buttons also perform frame advance/reverse playback during pause.

Press **▶** to resume normal playback.

Many DVD-Audio discs include slide show and page turn capabilities. Press **◀/▶** to move to a previous/next page. This function is only for DVD-Audio.

Notes

– Some BD/DVD discs are not compatible with frame advance/reverse playback.

– Depending on the disc, this Player resumes playback from the point that where the Player was previously stopped. To play back from the beginning, press **■** twice and then **▶**.

- ⑰ **SA-CD/CD**: Switches the playback layer of a hybrid SA-CD between SA-CD and CD (p. 4).

Hint

– The SA-CD/CD indicator (p. 5) on the front panel lights up when an SA-CD is loaded and the SA-CD layer is selected (p. 34).

Notes

– Audio signals are only output from the AUDIO OUT jacks (p. 11) while the SA-CD layer is selected.
– Audio signals recorded in DSD multi-channel format cannot be played on this Player.

- ⑱ **PURE DIRECT**: Changes Pure Direct mode. Pure Direct mode shown below will change each time you press the button. Pure Direct mode improves audio quality. PURE DIRECT on the front panel lights up when Pure Direct mode is set to mode 1/mode 2.

Mode 1: Front panel display is turned off, and video signals are not output. This mode is suitable listening audio.

Mode 2: Front panel display is turned off, and video signals from other than HDMI terminal are not output. This mode is suitable for watching movies with high quality sound.

off: Normal play back.

- ⑲ **DIMMER**: Changes brightness of the front panel display in 5 steps.
- ⑳ **DIGEST** **PHOTO**: Shows 12 photo thumbnails. When thumbnails are displayed, you can proceed to the next/previous page with **◀◀/▶▶**.
- DVD** **VIDEO**: Displays Bookmark select bar (p. 25).
- ㉑ **⏻**: Turns this Player on or sets it to the standby mode.
- ㉒ **ZOOM** **DVD** **VIDEO** **PHOTO**: Zooms in/out. The size of the screen will change each time you press the button (zoom in/out: 3 steps each).

Continued to the next page. ➔

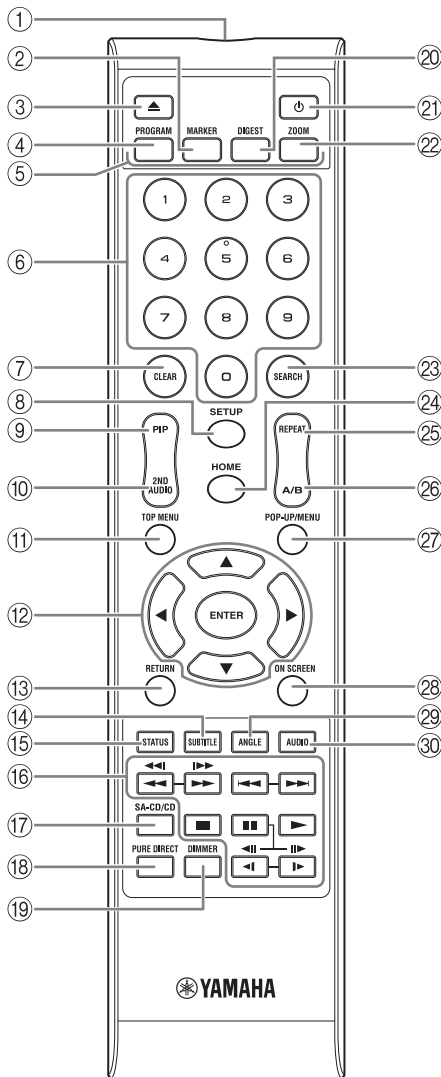

- 23 **SEARCH** [BD] [DVD] [CD] [VIDEO] [MUSIC]: Jumps to a specified point during playback. For details on this function, refer to “Using search” (p. 25). You can also select this item from status menu (p. 24).
 - 24 **HOME**: Displays the HOME menu screen (p. 19).
 - 25 **REPEAT** [BD] [DVD] [CD] [VIDEO] [MUSIC]
 - PHOTO**: Changes repeat mode. Repeat mode shown below will change each time you press the button.
 - : Repeats the title being played back.
 - : Repeats the chapter being played back.
 - : Repeats the folder being played back.
 - : Repeats all tracks/files on the disc.
 - : Repeats the track/file being played back.
 - 26 **A/B** [BD] [DVD] [CD] [VIDEO] [MUSIC]: Plays back a specific part you want to repeat.
 - 1 Press **A/B** at the scene where you want to set the start point. “A-” is displayed on the screen.
 - 2 Press **A/B** again at the scene where you want to set the end point. “A-B” is displayed on the screen. Repeat playback starts.
 - 3 To cancel the repeat playback, press **A/B**. “A-B” disappears and the repeat playback is finished.
- Note**
- This function cannot be performed depending on the specifications of the disc.
- 27 **POP-UP/MENU** [BD] [DVD]: Displays pop-up menu. The menu contents displayed vary depending on the disc. For details on how to see and operate the pop-up menu, refer to the manual for the disc. The top menu screen may be displayed by pressing **POP-UP/MENU** depending on the DVD.
 - 28 **ON SCREEN**: Displays On Screen menu (p. 23).
 - 29 **ANGLE** [BD] [DVD]: Changes the camera angle if video is recorded with multiple angles. The Angle Mark () is displayed on the screen when this function is available. You can also select this item from On Screen menu (p. 23).
- Note**
- Angle Mark is displayed only when the Angle Mark is set to on (p. 31).
- 30 **AUDIO** [BD] [DVD]: Changes the audio language or format. You can also select this item from On Screen menu (p. 23).

ID function

You can change the remote control ID to prevent unwanted operation of the other Yamaha player such as DVD player. If you have changed the remote control ID, make sure that you select the same ID for the main unit. The default setting is ID1.

1 Remote control setting

To change the ID from ID1 to ID2, press and hold the red color button and **2** of number button simultaneously for 7 seconds. To change the ID from ID2 to ID1, press and hold the red color button and **1** of number button simultaneously for 7 seconds.

2 Main unit setting

Press and hold **|◀◀/◀◀|** and **▶▶/▶▶|** on the front panel simultaneously for 2 seconds to display current ID when:

- No disc is inserted in this Player.
- The disc tray is closed.
- Playback is stopped.
- “NO DISC” is displayed on the front panel display.

Keep pressing and holding the keys for another 2 seconds to change the ID between ID1 and ID2.

Note

- If the remote control is without batteries for a few minutes or if exhausted batteries remain in the remote control, the remote control ID is automatically set to ID1. If you want to use the remote control in ID2 setting, install new batteries and set the remote control ID again.

INTRODUCTION TO CONNECTIONS

Find the corresponding connection method on your video/audio equipment. We recommend that you use the HDMI terminal which provides high quality digital audio and video on a single connection. If you use the other terminals/jacks, connect the video first. Then connect the audio.

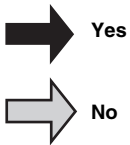
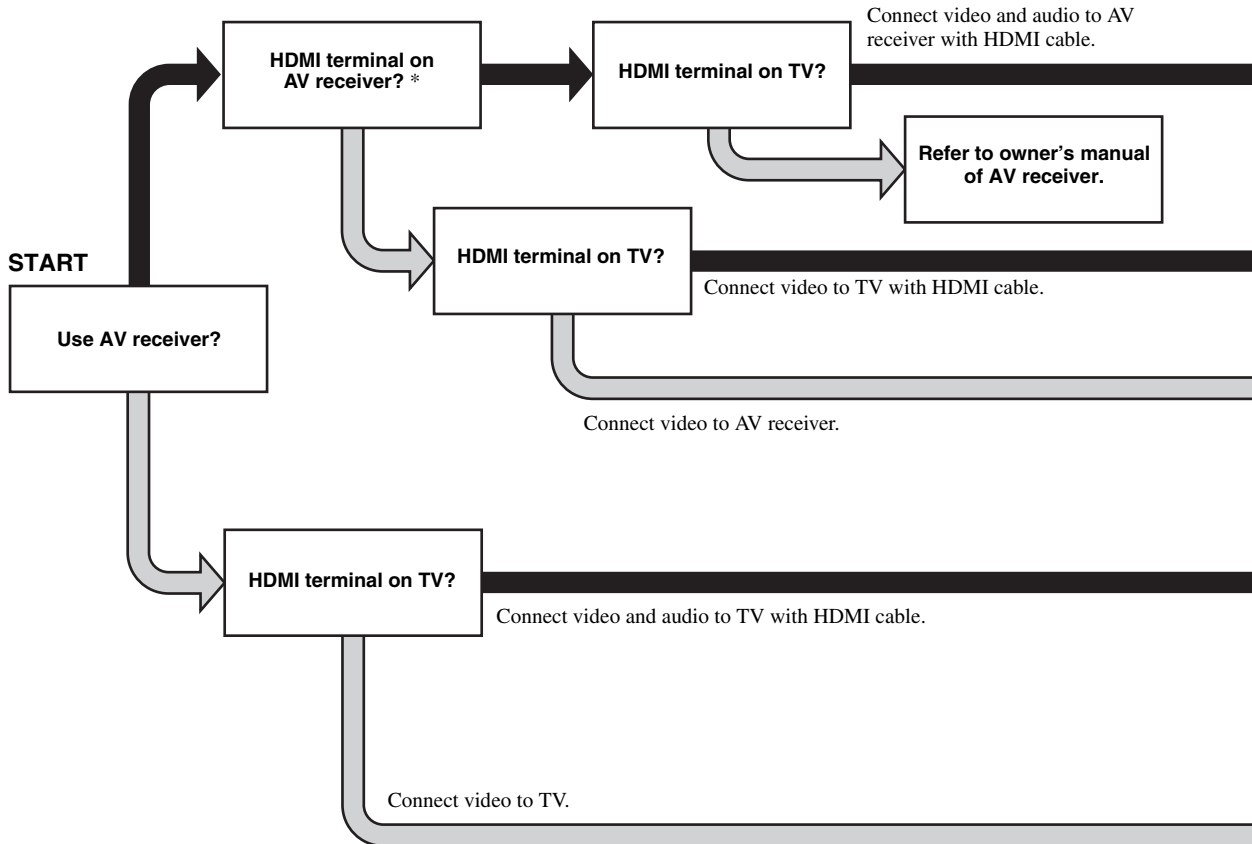

* When you connect to an AV receiver that cannot output the sound input via its HDMI terminal, refer to the owner's manual of your AV receiver.

■ Rear panel

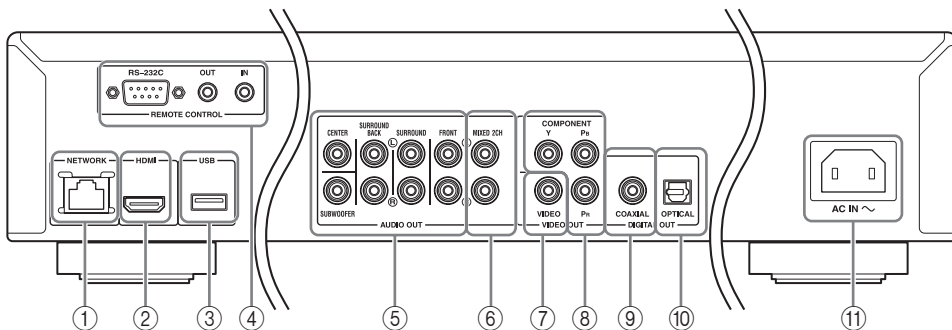

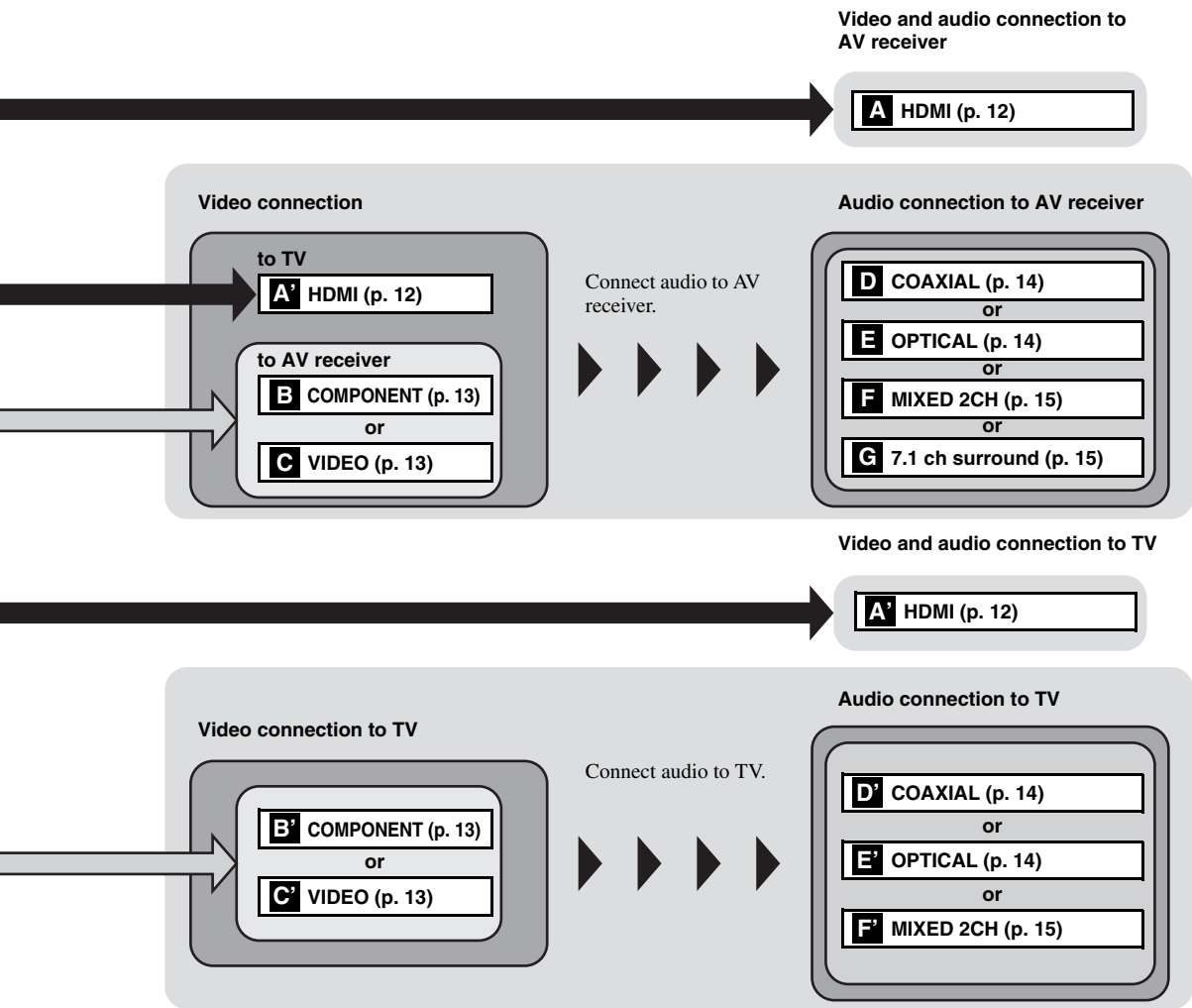

- ① NETWORK (p. 16)
- ② HDMI (p. 12)
- ③ USB port (p. 16)
- ④ REMOTE CONTROL (IN/OUT/RS-232C) (p. 17)
- ⑤ 7.1 ch surround (AUDIO OUT) (p. 15)

- ⑥ MIXED 2CH (AUDIO OUT) (p. 15)
- ⑦ VIDEO (p. 13)
- ⑧ COMPONENT (p. 13)
- ⑨ COAXIAL (p. 14)
- ⑩ OPTICAL (p. 14)
- ⑪ AC IN (p. 17)

HDMI CONNECTION

■ Connecting to the HDMI terminal

- You can enjoy high quality digital picture and sound through the HDMI terminal.
- Firmly connect an HDMI cable (commercially available) to the HDMI terminals.
- See page 35 for information on the audio/video output formats.
- Use HIGH SPEED HDMI cables that have the HDMI logo (as shown on the back cover).

Caution!

Do not connect the power cable of this Player until all connections are completed.

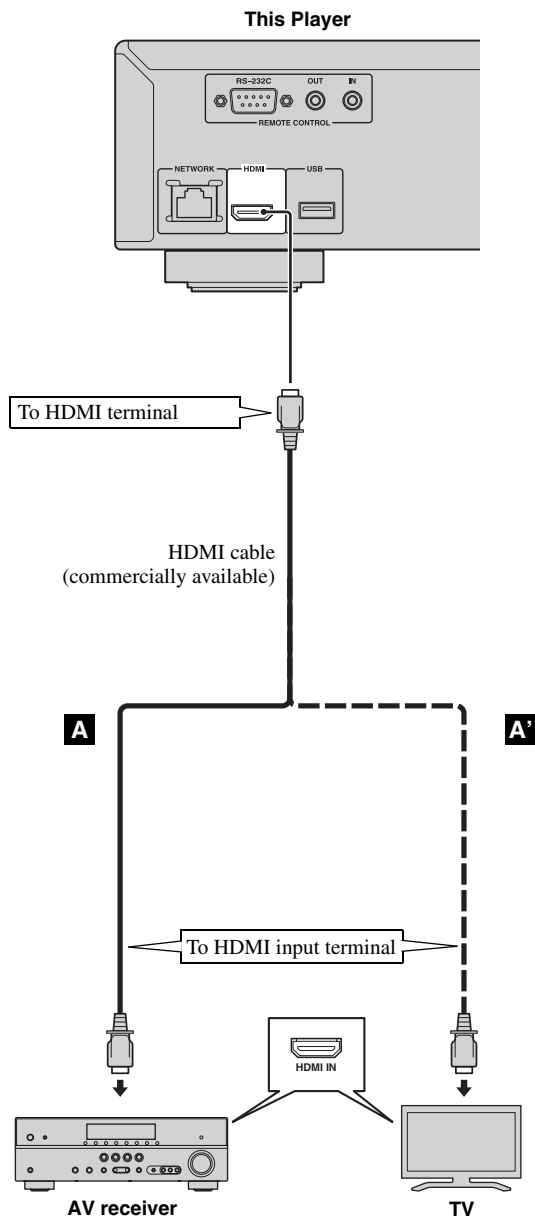

Hints

- When you use the HDMI Control function, refer to the "HDMI Control" (p. 30).
- For information on the output mode of HDMI terminal, refer to the "HDMI" (p. 34).
- When no picture is displayed, refer to "TROUBLESHOOTING" (p. 39).

■ Connection for the playback of Blu-ray 3D discs

To enjoy Blu-ray 3D discs on this Player, you need the following equipments and connections:

- You need a TV and an AV Receiver (if you need) that have 3D functionality.
- All the components must be connected with HDMI cables.
- Blu-ray disc should contain 3D images.

VIDEO CONNECTIONS

■ Connecting to the component/video jack

- You can enjoy accurate color reproduction and high quality images through the component jacks.
- Firmly connect a component video cable (commercially available) or a video pin cable to the COMPONENT jacks/ VIDEO jack.
- See page 36 for information on the video output formats.

Caution!

Do not connect the power cable of this Player until all connections are completed.

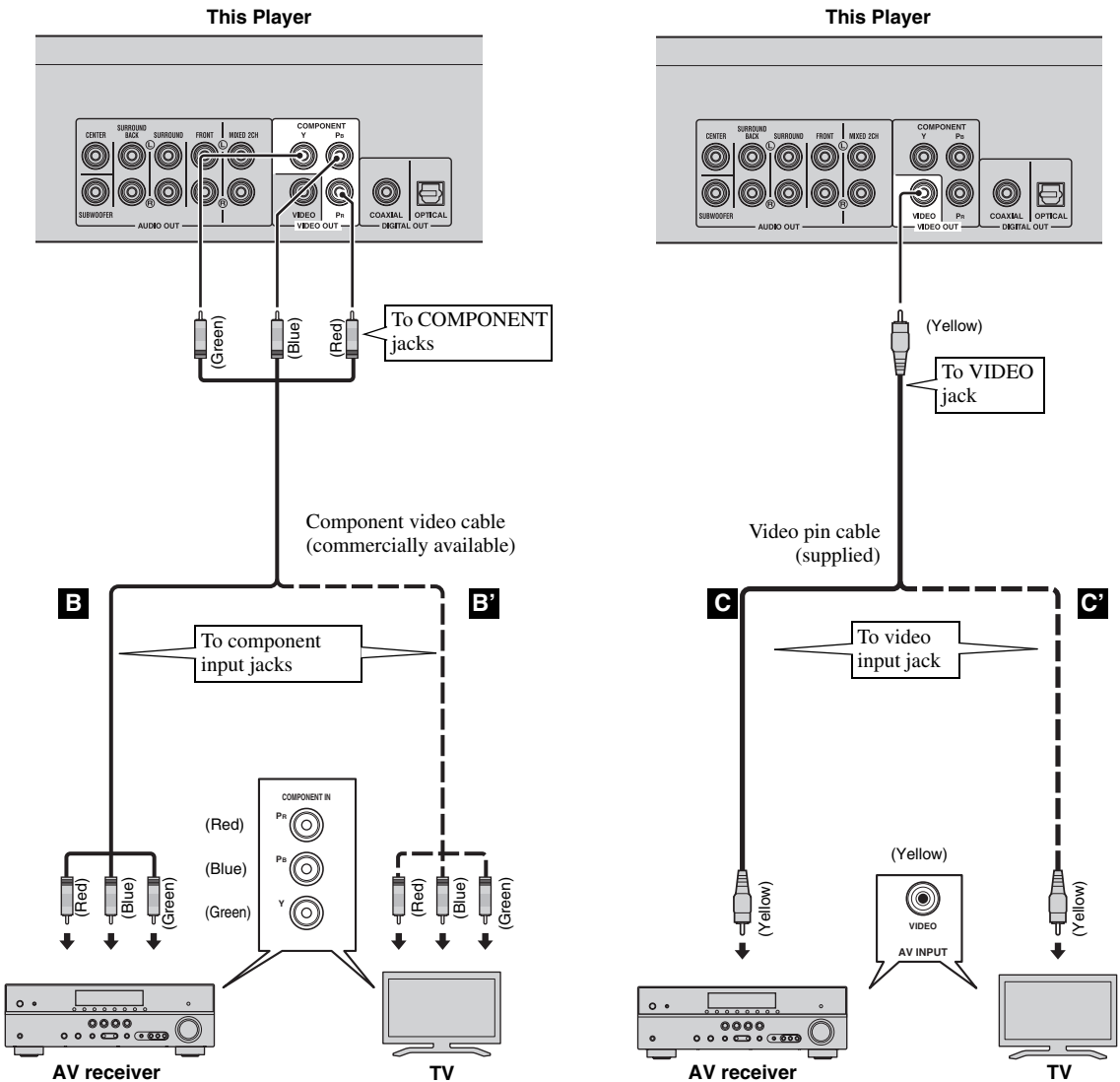

Notes

- If you play back the image via VCR, the image may deteriorate due to the copy guard function.
- To enjoy BD-3D discs on this Player, you need to connect an AV receiver, a TV, and this Player using HDMI cables. Refer to the previous page.

AUDIO CONNECTIONS

■ Connecting to the digital audio jack/terminal

- You can connect audio equipment or the TV to the COAXIAL jack/OPTICAL terminal.
- Firmly connect a Coaxial digital audio cable (commercially available) or optical cable (commercially available) to the coaxial digital audio jack or optical digital audio terminal.
- See page 35 for information on the audio output formats.

Caution!

Do not connect the power cable of this Player until all connections are completed.

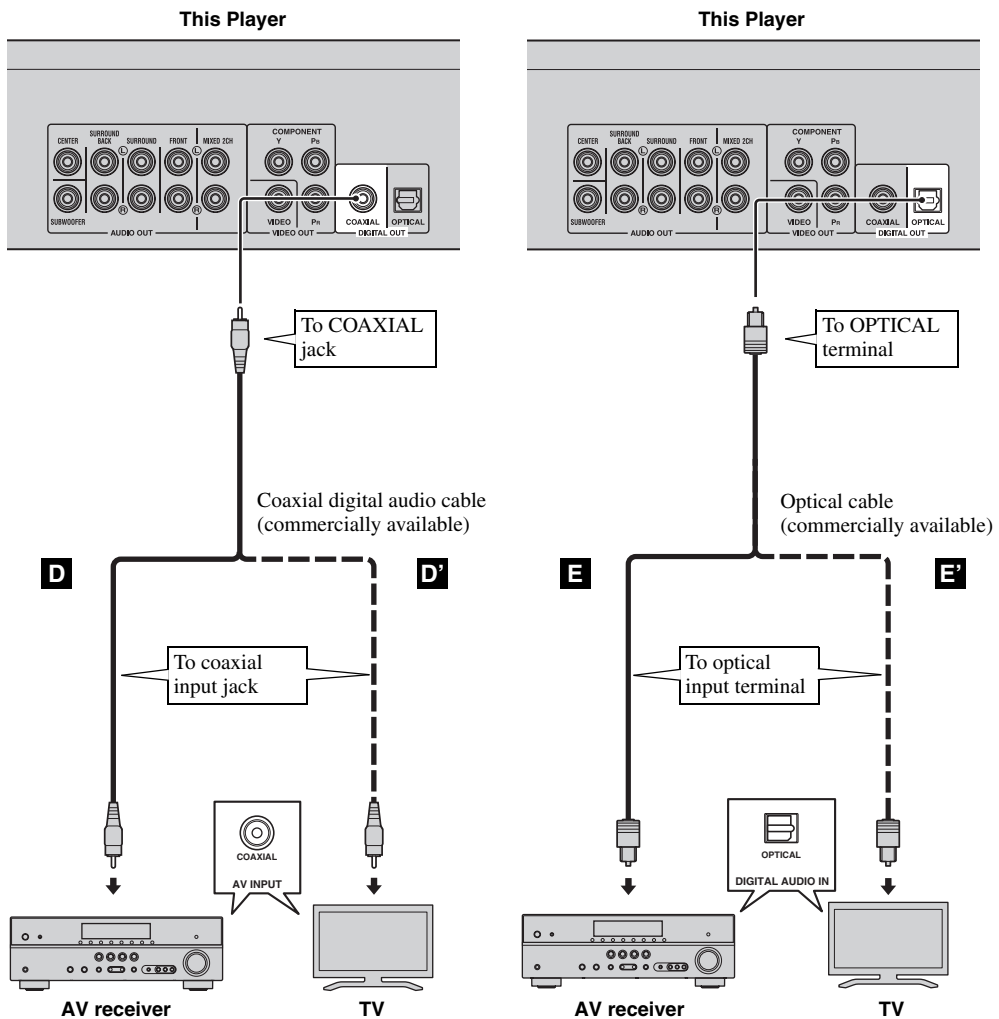

Hint

- For information on the output mode of COAXIAL jack/OPTICAL terminal, refer to the "Coaxial/Optical" (p. 34).

■ Connecting to the audio jacks

- You can connect audio equipment or the TV to the MIXED 2CH/7.1 ch surround jacks.
- Firmly connect audio pin cables (supplied and commercially available) to the MIXED 2CH jacks or 7.1 ch surround jacks.
- See page 35 for information on the audio output formats.
- If you want to reproduce multi-channel SA-CD and DVD-Audio, connect 7.1 ch surround jacks to the corresponding input jacks of your AV receiver using commercially available audio pin cables.

Caution!

Do not connect the power cable of this Player until all connections are completed.

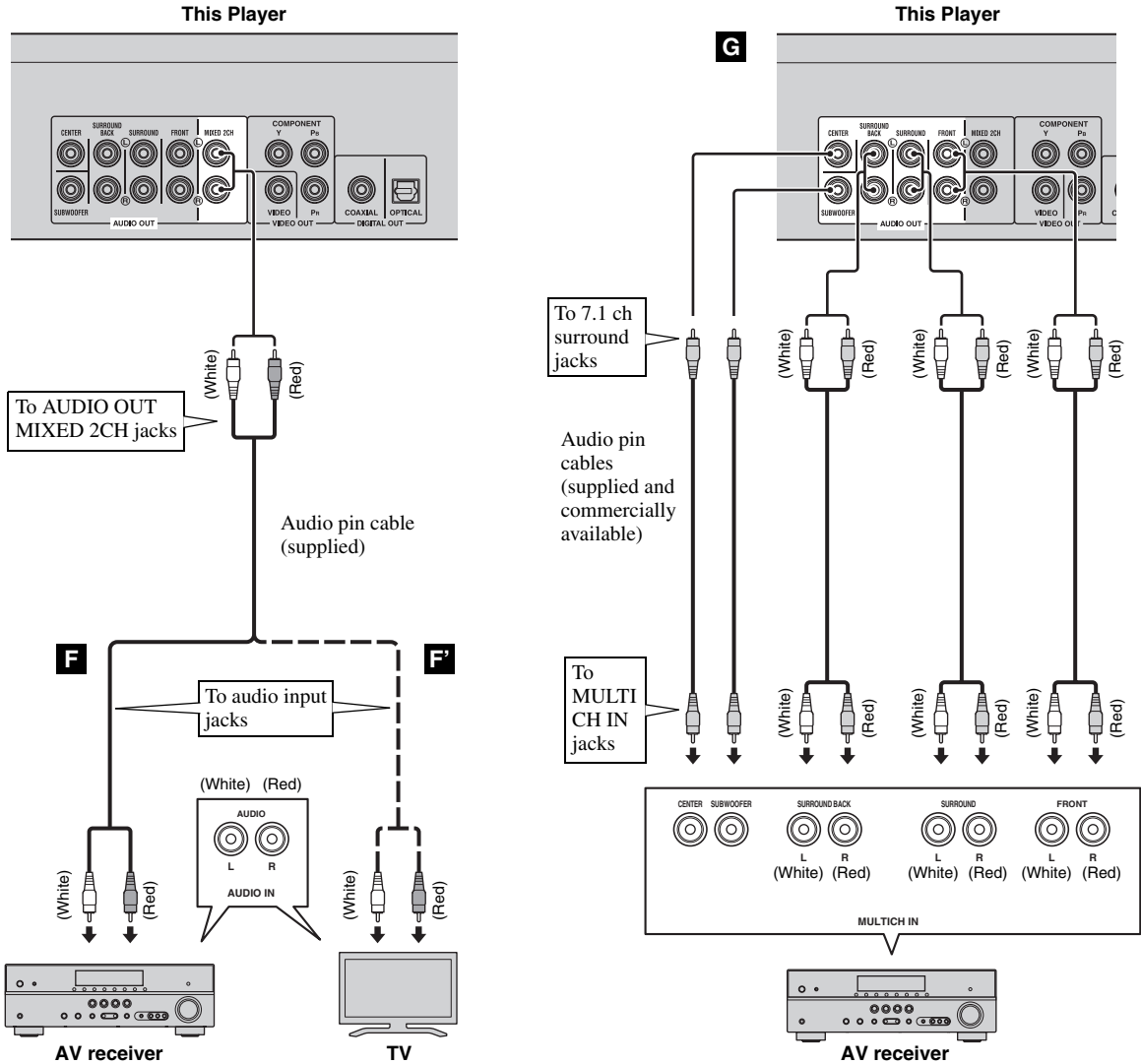

Hints

- You can connect a subwoofer to the SUBWOOFER jack directly. When you connect TV to this Player directly, connect an active subwoofer such as Yamaha Active Servo Processing Subwoofer System to this jack.
- To output the audio signal from the MIXED 2CH/7.1 ch surround jacks, refer to "Speaker Setting" (p. 34).

NETWORK AND USB CONNECTION

■ Connecting to the NETWORK terminal and USB port

- PC contents can be played back by connecting this Player to the network.
- You can enjoy a variety of contents with interactive functions by connecting to the internet when playing BD-Live compatible discs. Refer to page 26 regarding further information on BD-Live functions.
- You can connect a USB memory device (2 GB or greater and formatted with FAT 32/16) for BD Local Storage to the USB port on the rear panel (or front panel) of the player to save the BD-Live data or to upgrade the software of this Player.
- Firmly connect a network cable (commercially available) and a USB memory device (commercially available) to the NETWORK terminal and USB port.
- Use only an STP (shielded twisted pair) network cable.
- When using the internet, a broadband internet connection as shown below is required.
- Connect the other connector of the network cable to the hub/broadband router.

Before using the USB memory device

CAUTION:

- Do not remove the USB memory device or unplug the power cable while the operations for BD-Live (p. 26) or software upgrade are being performed.
- Do not use a USB extension cable when connecting a USB memory device to the USB port of the Player. Using a USB extension cable may prevent the Player from performing correctly.

Note

- Yamaha cannot guarantee that all brands' USB memory devices will operate with this Player.

Notes

- When using a broadband internet connection, a contract with an internet service provider is required. For more details, contact your nearest internet service provider.
- Refer to the operation manual of the equipment you have as the connected equipment and connection method may differ depending on your internet environment.
- Use a network cable/router supporting 10BASE-T/100BASE-TX.

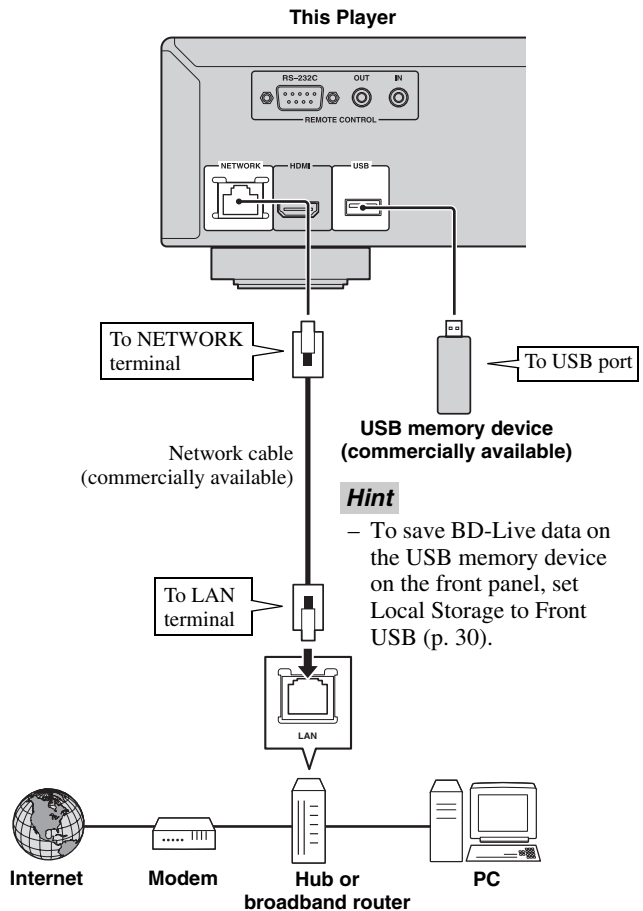

After connecting

- When you set the Network setting manually, refer to “Network” (p. 32).
- To play back the PC contents on your network, refer to “Using network content” (p. 21).

OTHER CONNECTIONS

■ Connecting to the REMOTE CONTROL jacks

- You can transmit and receive the remote control signals by connecting to the REMOTE CONTROL (OUT/IN) jacks.
- Firmly connect monaural 3.5 mm mini plug cables (commercially available) to the REMOTE CONTROL (OUT/IN) jacks.
- If your AV receiver is a Yamaha product and has the capability to transmit SCENE control signals, you can control the Player with the SCENE function.

Caution!

Do not connect the power cable of this Player until all connections are completed.

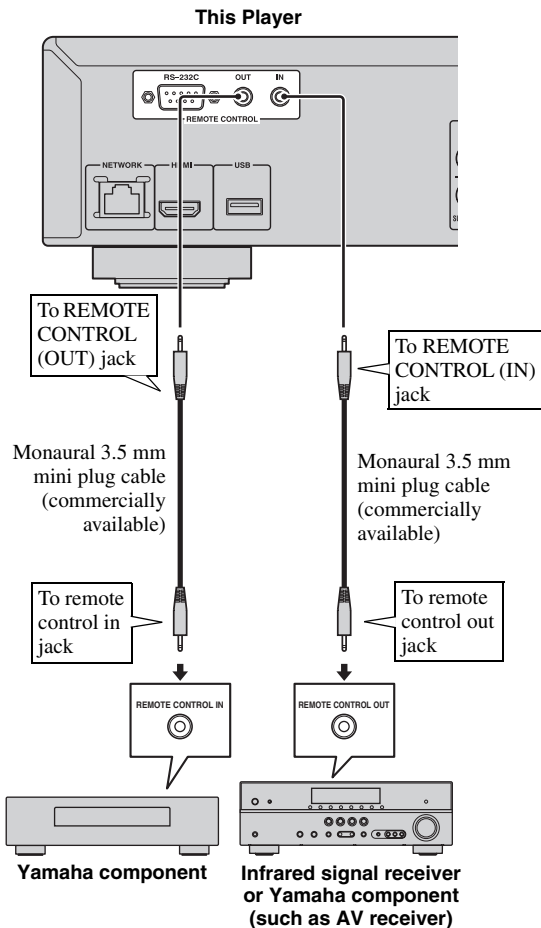

Hints

- For details about the SCENE function, refer to the owner's manual supplied with your Yamaha AV receiver.

- You can connect a Yamaha component (such as CD player) supports the SCENE function to the REMOTE CONTROL (OUT) jack of this Player.
- The RS-232C terminal is a control expansion terminal for commercial use. Consult your dealer for details.

■ Connecting the power cable

- After all connections are completed, plug the supplied power cable into the AC IN on the rear of the Player. Then plug into AC outlet.

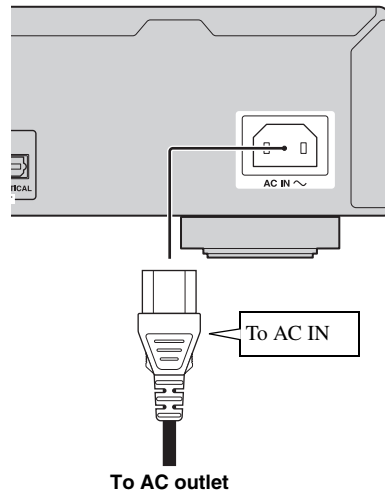

Note

- TO PREVENT RISK OF ELECTRIC SHOCK, DO NOT TOUCH THE UN-INSULATED PARTS OF ANY CABLES WHILE THE POWER CABLE IS CONNECTED.

INITIAL WIZARD/EASY SETUP

■ Setting with the Initial Wizard/ Easy Setup

Initial Wizard/Easy Setup allows you to set language, resolution, and screen aspect ratio easily. Initial Wizard screen is displayed when you turn this Player on for the first time after purchase or upgrade. Same setting can be performed from SETUP menu → System → Easy Setup.

- 1 When Easy Setup screen is displayed, Press **ENTER** to start Easy Setup.

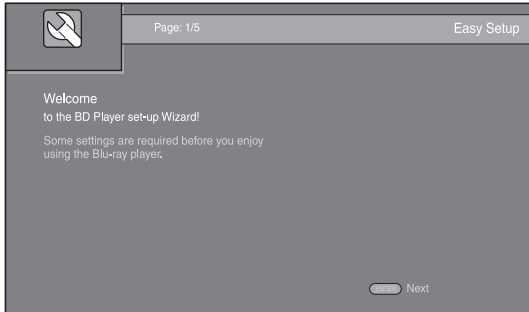

- 2 Press **▲/▼** to select the language you want to display on the screen, then press **ENTER**.

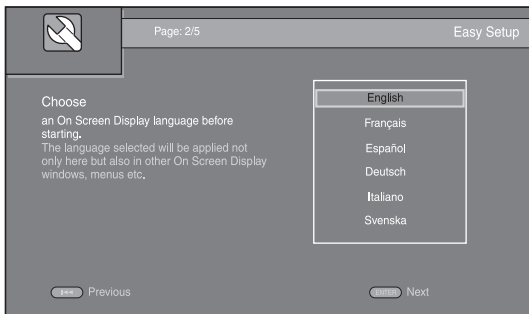

- 3 Press **▲/▼** to select the resolution, then press **ENTER**. For details on setting items, see “Resolution” (p. 33).

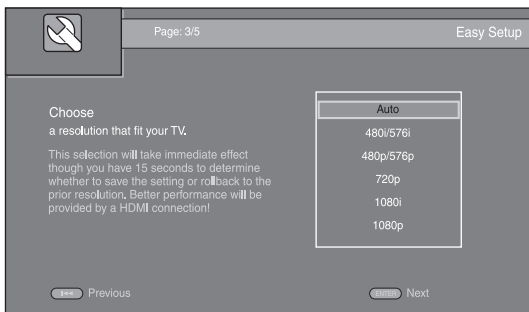

- 4 Press **▲/▼** to select the screen aspect ratio, then press **ENTER**. For details on setting items, see “TV Screen” (p. 32).

Easy Setup is completed.

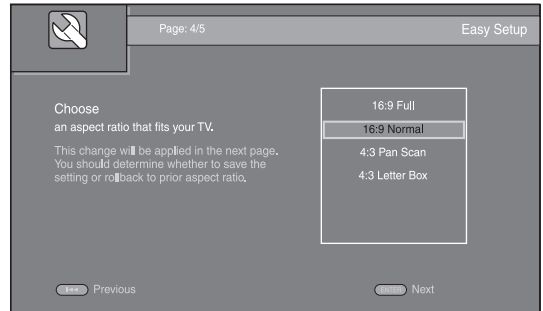

- 5 Press **ENTER** to exit Easy Setup.

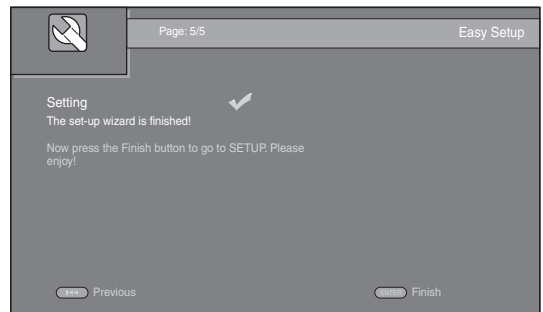

Notes

- When no picture is displayed after Initial Wizard/Easy Setup is completed, refer to “TROUBLESHOOTING” (p. 39).
- A warning message concerning 3D video playback appears when this Player is turned on. Press **ENTER** to dismiss the message or **CLEAR** to disable it (p. 30).

HOME/MEDIA MENU

HOME and MEDIA menus allow you to browse and play multi-media files on data discs, USB memory devices and your network.

Note

- For details on playable disc and format, see page 3.

■ Playing back photo/music/video

Basic operation

▲/▼: Moves the focus.

◀: Returns to the parent folder.

▶: Checks/unchecks single folder/file.

HOME: Moves to/exits HOME menu screen.

ENTER: Confirms the folder/file.

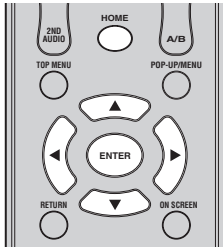

Icons on the top of MEDIA menu

Ⓚ: Plays back the disc on the tray, or displays contents in the data disc.

🗑️: Displays contents in the USB memory device connected to the USB port.

🌐: Searches for a DLNA (p. 21) server on the network.

🖥️: Displays contents on the connected DLNA server.

Common operations for playing back files in a selected folder

Example: Selecting a movie file on a USB memory device

Note

- Stop the playback of the video before you move to MEDIA menu screen.

- 1 Press **HOME** to move to HOME menu screen. Press **◀▶** to select MEDIA, then press **ENTER**.

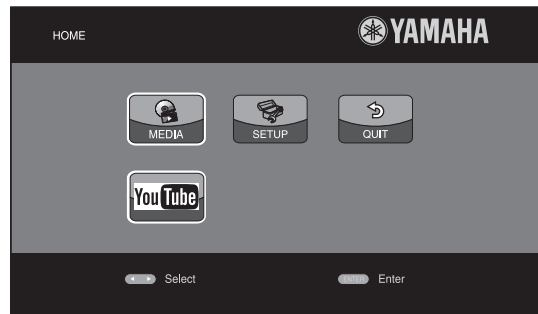

- 2 MEDIA screen appears.

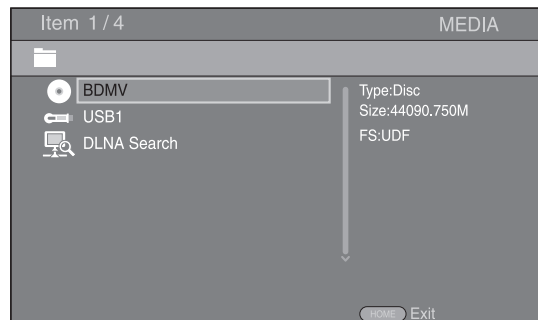

- 3 Select the item which contains the file you want to play back, then press **ENTER**.

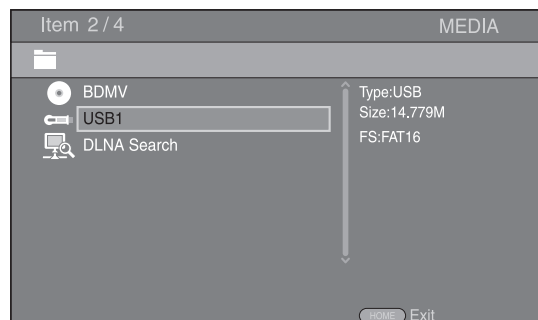

- 4 Select the Photo, Music, Video or AVCHD folder you want to play back, then press **ENTER**.

To return to the parent folder, press ◀ or select .

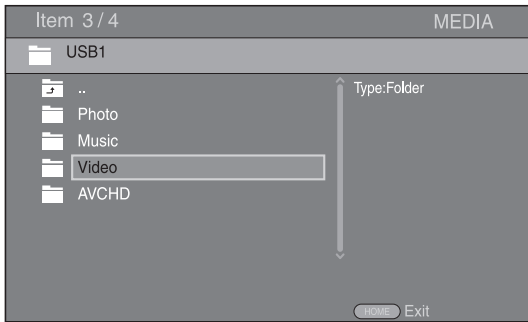

Note

- Note that the only the file type selected on this step will be displayed in the following step. For example, if you selected Photo folder in this step, only photo files are displayed after this step. When you play back other than photo, return to this hierarchy and select file type again.

- 5 Select the folder(s) containing the file you want to play back.

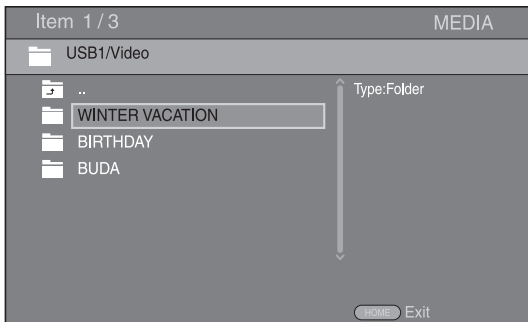

- 6 Select the file you want to play back, then press **ENTER**.

When a video file is selected, playback starts.

When a music file is selected, status screen is displayed and playback starts.

When a photo file is selected, slide show starts.

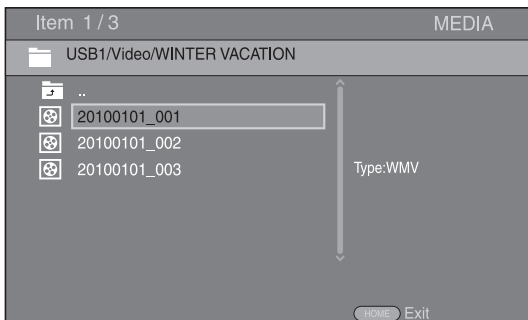

Hint

















- To enjoy slide show with music, press **HOME** to return to the HOME menu screen while music is played back, and select photo file.

Note

- The displayed file may not be played back depending on the content.

Operations for viewing photos

While viewing photos, the buttons on the remote control work as shown below.

- : Stops slide show and returns to the file browser.
- : Pauses a slide show.
- : Plays a slide show.
- : Moves to a next photo.
- : Moves to a previous photo.
- : Makes a slide show faster in 3 steps.
- : Makes a slide show slower in 3 steps.
- : Inverts a photo.
- : Reflects a photo.
- : Rotates a photo counterclockwise.
- : Rotates a photo clockwise.
- ZOOM:** Zooms in/out a photo (zoom in/out: 3 steps each).
 - //: Pan in zoom mode when a photo is larger than the screen.
- DIGEST:** Switches to thumbnail mode (p. 7). When thumbnails are displayed, you can proceed to the next/previous page with /.

■ Using network content

This Player is a DLNA certified digital media player. You can manage photo, music and video contents stored on DLNA servers on your home network.

About DLNA

DLNA (Digital Living Network Alliance) provides easy sharing of digital media through network in the home, and you can enjoy digital contents stored on your DLNA-server-software-installed PC or other DLNA compatible device with your TV via this Player. To connect this Player to your DLNA servers, some settings for the DLNA server or device are required. For details, refer to your DLNA server software or DLNA device.

Playing back shared contents

- 1 To play back files on your PC, install a DLNA server software, such as Windows Media Player 12, and share files you want to play back.
- 2 Turn on the PC with DLNA server software installed or the DLNA device connected to your home network.
- 3 Press **HOME** to display HOME menu screen. Then select **MEDIA** to move to MEDIA menu. The DLNA servers connected to the network are listed on the screen.

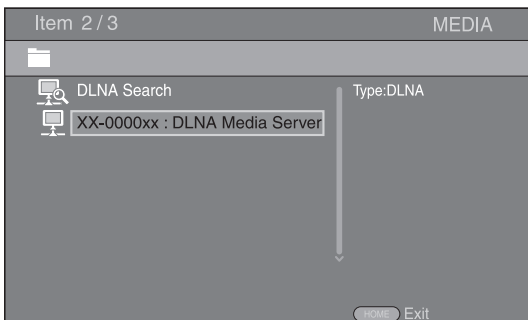

Notes

- If your DLNA server is not listed, select DLNA Search to find it.
 - Depending on the DLNA server, this Player may need to be permitted from the server.
 - To play the file on the DLNA server, this Player and the server must be connected to the same access point.
 - The file requirements may not always be compatible. There may be some restrictions depending on file features and DLNA sever capability.
- 4 Select the file you want to play back.

Notes

- The playback and operating quality may be affected by your home network condition.
- The files from removable media such as USB memory devices or DVD-drive on your media server, may not be shared properly.

USING NETWORK SERVICES

You can instantly watch the videos that the following network services provide.

- YouTube

Notes

- Access to content provided by third parties requires a high speed internet connection and may also require account registration and a paid subscription.
- Third party content services may be changed, suspended, interrupted, or discontinued at any time without notice, and Yamaha disclaims any liability in connection with such occurrences.
- Some content may only be available for specific countries and may be presented in specific languages.
- Yamaha does not represent or warrant that content services will continue to be provided or available for a particular period of time, and any such warranty, express or implied, is disclaimed.

PLAYING VIDEOS FROM YouTube™

You can watch movies from YouTube over the internet using this Player.

The services may be changed without notice.

- 1 Press **HOME** to display HOME menu screen.

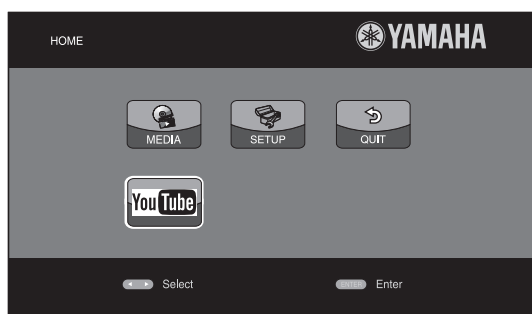

Hint

- The HOME menu screen may differ depending on the model.

- 2 Press **▲/▼/◀/▶** to select YouTube, then press **ENTER**.

Hint

- To return to the HOME menu screen, press **RETURN**.

ADVANCED PLAYBACK OPERATION

This chapter explains playback of commercially available BD and DVD discs, SA-CDs, CDs, and recorded DVD-RW/R discs.

Note

- For the basic playback operation, see page 6.

■ On Screen menu

To display On Screen menu, press **ON SCREEN**. After that, press **▲/▼/◀/▶** to select an item, then press **ENTER** to operate the desired function.

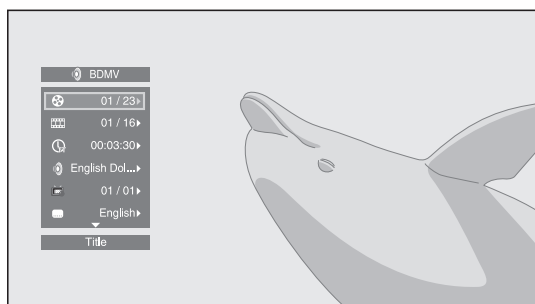

On Screen menu contains following items.

Title **BD** **DVD** **VIDEO** : Shows the title number being played back. You can skip to the desired title by selecting it from this item.

Chapter **BD** **DVD** **VIDEO** : Shows the chapter number being played back. You can skip to the desired chapter by selecting it from this item.

Track/File **CD** **VIDEO** **MUSIC** **PHOTO** : Shows track/file number being played back. You can skip to the desired track/file by selecting it from this item.

Time **BD** **DVD** **CD** **VIDEO** **MUSIC** : Shows the playback time. Select display type from the following:

- Elapsed playback time of the title, chapter, disc, track or file
- Remaining playback time of the title, chapter, disc, track or file

Mode/Play Mode

DVD **CD** **VIDEO** **MUSIC** **PHOTO** : Shows current playback mode. You can select playback mode from the following:

- CD**
 - Normal: Normal playback.
 - Shuffle: Random playback without repetition.
 - Random: Random playback with repetition.

DVD

- Normal
- Shuffle CH (chapter)
- Shuffle TT (title)
- Shuffle All
- Random CH (chapter)
- Random TT (title)
- Random All

VIDEO MUSIC PHOTO

- Normal
- Shuffle F (folder)
- Shuffle All
- Random F (folder)
- Random All

Audio **BD** **DVD** **VIDEO** : Shows audio language/signal of BD/DVD disc currently selected. You can select the desired type of audio.

Angle **BD** **DVD** : Shows the currently-selected angle number. If the video is recorded with multiple angles, you can change the angle.

Subtitle **BD** **DVD** **VIDEO** : Shows the currently-selected subtitle language when the subtitle is provided.

Subtitle Style **BD** : Shows the currently-selected subtitle style. This function is available only for Video-file external subtitle. You can select the desired text style of subtitle.

Bitrate **BD** **DVD** **CD** **VIDEO** **MUSIC** : Shows bitrate of the audio/video signal.

Second Video **BD** : Turns the PIP on/off (p. 6).

Second Audio **BD** : Turns the secondary audio on/off (p. 6).

Ins Search

BD **DVD** **CD** **VIDEO** **MUSIC** : Skips 30 seconds.

Ins Replay

BD **DVD** **CD** **VIDEO** **MUSIC** : Replays the content from 10 seconds before.

Slide Show PHOTO :

Shows slide show speed. You can select the slide show speed from Slow/Medium/Fast.

Transition **PHOTO** : Shows how photo appears on the screen. You can select the transition type.

Code Page **VIDEO** : Selects character code of subtitle you added to DivX video (p. 41).

■ Status menu

This shows various settings, such as subtitles, angle settings and the title/chapter/track number currently played back. To display status menu, press **STATUS**. Status menu contains following menus.

BD DVD VIDEO

Example: Icons when playing BD

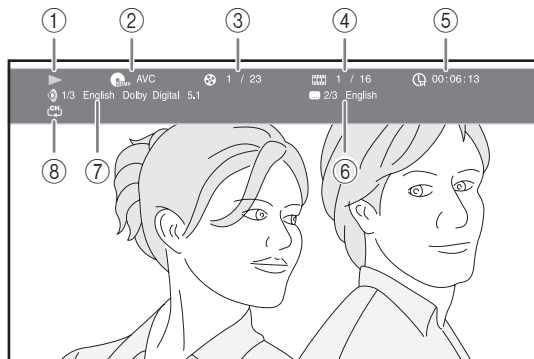

- ① **(Playback status)**
- ② **(Disc type/video file icon)**
- ③ **(Title number being played):** You can jump to specified title with **SEARCH** button (p. 8).
- ④ **(Chapter number being played):** You can jump to specified chapter with **SEARCH** button (p. 8).
- ⑤ **(Elapsed playback time):** You can jump to specified point with **SEARCH** button (p. 8).
- ⑥ **(Subtitle currently selected):** You can change the subtitle language with **SUBTITLE** button.
- ⑦ **(Audio currently selected):** You can change the audio language or format with **AUDIO** button.
- ⑧ **(Repeat mode):** Shows current repeat mode (p. 8).

DVD CD MUSIC

Example: Icons when playing music file

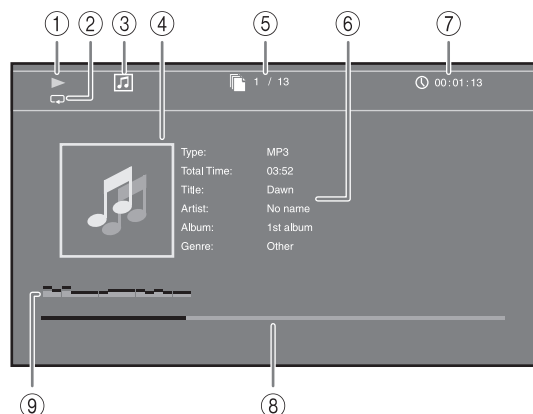

- ① **(Playback status)**
- ② **(Repeat mode):** Shows current repeat mode (p. 8).
- ③ **(Disc type/music file icon)**
- ④ **(Artwork) MUSIC:** Displays artwork if the file contains it.
- ⑤ **(Track/file number being played):** You can jump to specified track with **SEARCH** button (p. 8).
- ⑥ **(Information) MUSIC:** Displays music information if the file contains them.
- ⑦ **(Elapsed playback time):** You can jump to specified point with **SEARCH** button (p. 8).
- ⑧ **(Progress bar) MUSIC:** Shows progress status of current song.
- ⑨ **(Audio level meter):** displays current volume level.

PHOTO



- ① **(Playback status)**
- ② **(Photo file icon)**
- ③ **(File number being displayed)**
- ④ **(Repeat mode):** Shows current repeat mode (p. 8).
- ⑤ **(Slide show speed)**

■ Using Bookmark BD DVD VIDEO

This allows you to set Bookmark at the specified point of the video. After Bookmark is set, you can move to the point you set using this function. You can set up to 12 Bookmarks.

- 1 Press **MARKER** during playing back the movie to set Bookmark. Bookmark number, and the status are displayed.

Bookmark: 1/12 Title: 1 Chapter: 1 Time: 00:01:26

- 2 After Bookmark is set, press **DIGEST** to display Bookmark select bar.

Title:01 Chapter:01 Time:00:01:26 Bookmark
 01 02 03 04 05 06 07 08 09 10 11 12 Clear

- 3 Press **◀/▶** to select the Bookmark you want to play back, then press **ENTER**. Press **CLEAR** to delete the selected Bookmark.

Note

- When playback is finished (e.g., ejecting the disc, pressing **■** twice), Bookmarks are automatically deleted.

■ Program play BD DVD CD

This allows you to program playback order of audio disc tracks or DVD chapters.

Press **PROGRAM** during playback to display the PROGRAM window to program playback order. You can program up to 15 tracks/chapters.

Example: Programming the playback order of CD tracks

- 1 Press **PROGRAM** during playback.

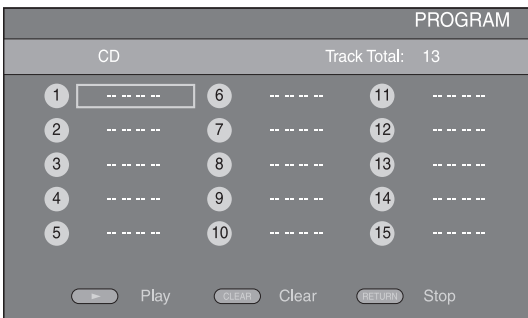

- 2 Press **ENTER** to program playback order. For audio disc, press **▲/▼** to select a desired track then press **ENTER**. For DVD-Video disc, select a desired title (shown as TT) and chapter (shown as CH) instead of a track. To clear a set track, select the track you want to clear, then press **CLEAR**. Press **RETURN** to cancel the Program play.

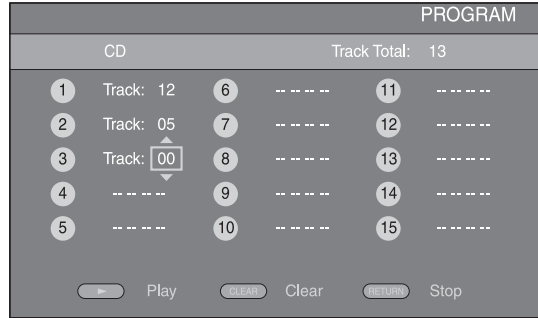

- 3 After programming is finished, press **▶** to set and start program playback.
- 4 To cancel program play, stop playback completely by pressing **■** twice.





■ Using search

BD DVD CD VIDEO MUSIC



This allows you to jump to the specified point during playback.

- 1 Press **SEARCH** during playback. Status bar appears.
- 2 Press **▲/▼/◀/▶** to select one of the item below, then press **ENTER**.



BD DVD :

- Title number (shown as )
- Chapter number (shown as )
- Elapsed title time (shown as )
- Elapsed chapter time (shown as )

CD :

- Track number (shown as )
- Elapsed track time (shown as )
- Elapsed disc time (shown as )

VIDEO MUSIC :

- File number (shown as )
- Elapsed file time (shown as )

- 3 Press **▲/▼** or number buttons to set/adjust the value of the focused item, and press **ENTER** to jump to the specified point.
- 4 To close the status bar, press **STATUS**.

■ Enjoying BONUSVIEW™ and BD-Live™

This player supports BONUSVIEW (p. 41) (BD-ROM Profile 1 Version 1.1) and BD-Live (p. 41) (BD-ROM Profile 2) playback functions.

Note

- Functions and playback method vary depending on the disc. See the guidance on the disc or the supplied user's manual.

■ Using Picture in Picture function (secondary audio/video playback)

BD-Video that includes secondary audio and video compatible with Picture in Picture can be played back with secondary audio and video simultaneously as a small video in the corner.

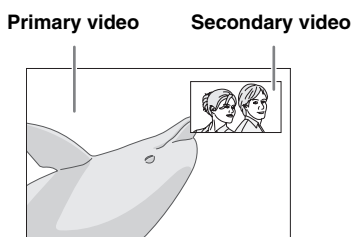

While PIP Mark (PIP) or Secondary Audio Mark (SA) is displayed, press PIP to turn the Picture in Picture function on/off.

Notes

- To listen to secondary audio, make sure that the Audio Output setting (Coaxial/Optical or HDMI) is set to PCM or Reencode (p. 34).
- Depending on the disc, to listen to secondary audio, you may need to set secondary audio to on on the top menu of the disc (p. 7).
- The secondary audio and video for Picture in Picture may automatically play back and be removed depending on the content. Also, playable areas may be restricted.

■ Using the feature of BD-Live™

1. Set the Network setting (p. 32).

2. Connect the USB memory device to this Player (p. 16).

BD-Live data is saved in a USB memory device connected to this Player. To enjoy these functions, connect a USB memory device (2 GB or greater and formatted with FAT 32/16) supporting USB 2.0 High Speed (480 Mbit/s) to the USB port that you select on Local Storage (p. 30). The default setting is the USB port on the rear panel.

- BUDA folder is created automatically in the USB memory device when necessary.
- If there is insufficient storage space, the data will not be copied/downloaded. Delete unneeded data or use a new USB memory device.
- Some time may be required for the data to load (read/write).

Notes

- Yamaha cannot guarantee that all brands' USB memory devices will operate with this Player.
- Do not use a USB extension cable when connecting a USB memory device to the USB port of the player. Using a USB extension cable may prevent the player from performing correctly.

3. Play back the disc.

4. Run BD-Live according to the instructions on the disc.



Notes

- Regarding playback method of BD-Live contents, etc., perform the operations in accordance with the instructions in the BD disc manual.
- To enjoy BD-Live functions, perform the network connection (p. 16) and Network settings (p. 32).
- Refer to "BD-Live Connection" (p. 32) regarding the setup to restrict access to BD-Live contents.
- The time required to download the provided programs into the USB memory device connected to this Player varies depending on the internet connection speeds and the data volume of the programs.
- BD-Live programs provided through the internet may not be able to display the connection depending on the status (upgrading) of the provider. In such cases, take out the disc and try again.
- If the BD-Live screen does not appear for a while after you select the BD-Live function in the BD disc menu, the USB memory device may not have enough free space. In such cases, eject the disc from the player, and then erase the data in the USB memory device using the "Format" menu in the "Local Storage" (p. 30).

SETUP MENU

The SETUP menu enables various audio/visual settings and adjustments for functions using the remote control unit.

Menu/Submenu	Item	Function	Page		
 General Setting	System	Screen Saver	Sets screen saver on/off.	30	
		Disc Auto Playback	Sets this Player to start disc playback automatically.	30	
		HDMI Control	Sets this Player to receive control signal from the remote control of your TV/AV receiver.	30	
		Network Control	Sets the control via Ethernet to on/off.	30	
		Load Default	Resets all settings to the default setting except Security setting.	30	
		Upgrade	Performs upgrade of this Player.	30	
		Easy Setup	Sets language, resolution, screen aspect ratio.	30	
		Local Storage	Displays status of Local Storage (p. 30), formats Local Storage and selects the front/rear USB port for Local Storage.	30	
		3D Playback Message	Displays a warning message concerning 3D video playback when this Player is turned on.	30	
		Language	OSD	Selects the language for On Screen Display.	31
			Menu	Prioritizes the language for disc menu.	31
			Audio	Prioritizes the language for audio.	31
			Subtitle	Prioritizes the language for subtitle.	31
		Playback	Closed Caption	Sets the closed caption to on/off.	31
			Angle Mark	Sets to display the Angle Mark when BD/DVD with multiple angles is played back.	31
			PIP Mark	Sets to display the PIP Mark when BD/DVD with Picture in Picture is played back.	31
			Secondary Audio Mark	Sets to display the Secondary Audio Mark when BD/DVD with secondary audio is played back.	31
			DivX(R) VOD DRM	Displays registration code for DivX(R) video.	31
			DVD-Audio Mode	Sets DVD-Audio mode to DVD-Audio/DVD-Video.	31
		Security	Change Password	Changes password for Parental Control and Country Code.	31
			Parental Control	Sets the Parental Control depending on the disc content.	31
			Country Code	Sets your Country Code.	31
		Network	Internet Connection	Sets the internet connection to Enable/Disable.	32
			Information	Displays network information screen.	32
			Connection Test	Performs the network connection test.	32
			IP Setting	Sets the IP setting to Auto/Manual.	32
			BD-Live Connection	Sets the BD-Live connection to Permitted/Partial Permitted/Prohibited.	32
			DLNA	Sets the DLNA to Enable/Disable.	32
			Proxy Setting	Sets the proxy setting.	32

Menu/Submenu	Item	Function	Page	
 Display Setting	TV	3D Output	Selects 3D or 2D videos.	32
	TV Screen	Sets the screen aspect ratio of the connected TV, and adjust the video output.	32	
	Resolution	Selects the resolution of output video.	33	
	TV System	Selects the TV System from NTSC/PAL/Multi.	33	
	Color Space	Selects Color Space from RGB/YCbCr 4:4:4/YCbCr 4:2:2/ Full RGB.	33	
	HDMI Deep Color	Selects HDMI Deep Color from 30 bits/36 bits/Off.	33	
	HDMI 1080p 24Hz	Sets HDMI 1080p 24Hz to auto/off.	33	
	Lip Sync	Adjusts the lag between video and audio, such as when the mouth movement is out of sync with the voice.	33	
	Video Process	Video Mode	Adjusts the visual image.	33
	Color Adjust	Adjusts Brightness/Saturation/Hue for each color.	33	
	Auto Contrast	Adjusts contrast to optimize the played back image.	33	
	Noise Reduction	Sets the level of Noise Reduction.	33	
	De-interlacing Mode	Sets how to detect the video signal.	34	
	 Audio Setting	Audio Output	Coaxial/Optical	Selects the output mode of COAXIAL jack/OPTICAL terminal from Bitstream/PCM/Reencode/Off.
HDMI		Selects the output mode of HDMI terminal from Bitstream/PCM/Reencode/Off.	34	
Downsampling		Selects the digital audio signal down sampling frequency from 48k/96k/192k.	34	
DRC		Sets the DRC (Dynamic Range Compression).	34	
SACD Output		SACD Priority	Selects a contents when Hybrid SA-CD is played back.	34
HDMI Output		Selects the output mode of HDMI terminal from DSD/PCM when SA-CD is played back.	34	
Speaker Setting		Configuration	Sets the audio output of 7.1 ch surround jack.	34
2ch Downmix		Selects down mix method to analog 2-ch.	34	
Post Process		Up Mix	Multi-channelizes the 2-channel audio signal.	34
 System Information		Displays software version and MAC address (p. 42).	34	

■ Example of SETUP menu operation

You need to call up the SETUP menu screen to perform settings for this Player. The following is the explanation for basic operations of the SETUP menu.



Example: Setting Parental Control

Note

- Some items cannot be set during playback. In this case, press **■** twice to stop playback completely before setting.

1. Display the SETUP menu screen.

Press **SETUP** to display the SETUP menu screen. Press **◀/▶** to select General Setting, then press **ENTER** or **▼**.

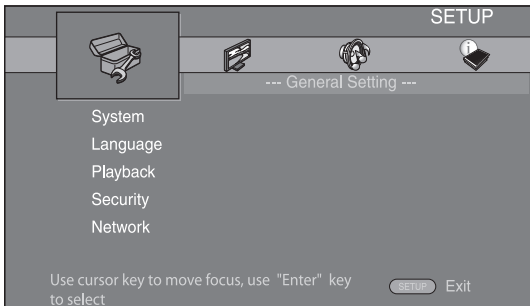

2. Select a Submenu.

Press **▲/▼** to select Security, then press **ENTER** or cursor **▶**.

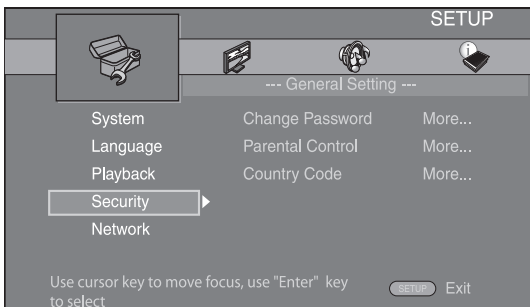

3. Select a menu item.

Press **▲/▼** to select Parental Control, then press **ENTER** or cursor **▶**.

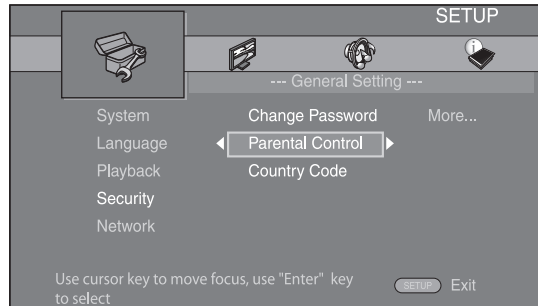

4. Enter password.

- Enter your password with number buttons.
- The default password is 0000.
- You cannot move to the next setting screen until you have input the correct password.
- To change the password, refer to “Change Password” (p. 31).

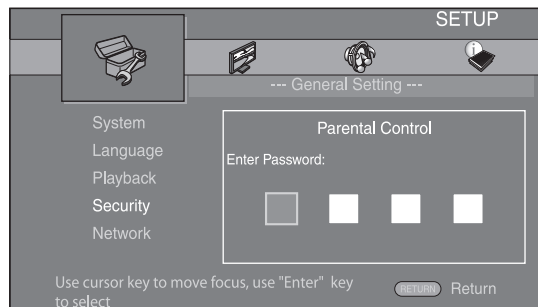

5. Select a next item.

Press **▲/▼** to select the Parental Control Level for BD/DVD, then press **ENTER**.

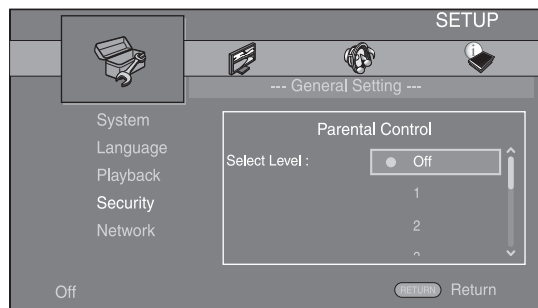

6. Exit the menu screen.

Press **◀** to return to the previous menu.

■ General Setting

The default settings are marked with “*”.

System

Screen Saver

You can set the screen saver to on/off.

When set to on, this Player will switch to screen saver mode if there is no operation for 3 minutes. After that, this Player will turn to standby mode when there is no operation for 6 minutes.

On*, Off

Disc Auto Playback

You can set Disc Auto Playback to on/off. When set to on, a disc will play back automatically after loading.

On*, Off

HDMI Control

You can set the Player to receive control signal from a TV/AV receiver compatible with the HDMI Control function via an HDMI cable (p. 12).

On, Off*

Using HDMI Control function

Using the HDMI Control function, you can interactively operate this Player with your TV (HDMI Control function supported).

When you connect this Player to the TV compatible with the HDMI Control function using an HDMI cable and set HDMI Control in the SETUP menu to on (p. 30), you can perform the function listed below.

- Automatic input select function
When you start playback of this Player, the input selector of the TV (and an AV receiver if this Player is connected to the TV via the AV receiver) is switched to this Player automatically. TV Power is turned on automatically depending on the TV.
- Automatic power off function
When you turn off the TV while this Player is in stop mode and the SETUP menu screen is not displayed, the power of this Player is also turned off automatically.

Notes

- HDMI Control function may not work properly depending on the TV.
- Functions other than ones shown above may work depending on the TV or AV receiver.
- In order to make the HDMI Control function available, set up settings for the HDMI Control function on ALL components (this Player, TV, and AV receiver). Certain operation may also be required.
- Each function may be set independently to activate/deactivate depending on the TV.
- Refer to the operation manuals supplied with the TV and/or AV receiver for details regarding setup.
- When set to on, power consumption during standby mode increases due to HDMI control function.

Network Control

You can set control via Ethernet to on/off. This player employs Yamaha Network Control protocol (YNC).

On, Off*

Notes

- When set to on, power consumption during standby mode increases due to network control function.
- When set to on, the system startup time is decreased.

Load Default

You can reset all settings of this Player to default setting except Security setting (p. 31). For details on default settings, see pages 27-34.

Upgrade

You can upgrade the software manually from Disc, USB Storage or Network. For details on software upgrade, refer to “SOFTWARE UPGRADE” (p. 37).

Easy Setup

You can perform Easy Setup (p. 18).

Local Storage

You can display Local Storage information, format Local Storage, and select Front USB/Rear USB to save the BD-Live data.

To format (empty) the “BUDA” folder in the USB memory device, select Information and press **ENTER** when “Format” is focused on the screen.

Front USB, Rear USB*

Hint

- Local Storage is used as an auxiliary memory when Blu-ray Disc is played back.

3D Playback Message

You can turn on or off a warning message concerning 3D video playback that appears on the TV when this Player is turned on.

On*, Off

Language

OSD

You can select the language for On Screen Display which is the messages or menu displayed on the screen such as SETUP menu.

English*, Français, Español, Deutsch, Italiano, Svenska, Nederlandse, Русский

Menu

You can prioritize the language for disc menu.

English*, Français, 中文, Español, Deutsch, Italiano, Nederlandse, Portuguese, Danish, Svenska, Finnish, Norwegian, Русский, Korean, Japanese, More

Audio

You can prioritize the audio language for BD/DVD playback. For details on setting items, see "Menu" (p. 31).

Subtitle

You can prioritize the language for Subtitle.

English, Français, 中文, Español, Deutsch, Italiano, Nederlandse, Portuguese, Danish, Svenska, Finnish, Norwegian, Русский, Korean, Japanese, More, Off*

Playback

Closed Caption

You can set to display the closed caption (p. 41) when BD/DVD with closed caption is played back.

On, Off*

Angle Mark

You can set to display the Angle Mark () when BD/DVD with multiple angles is played back.

On*, Off

PIP Mark

You can set to display the PIP Mark () when BD with picture in picture (p. 26) is played back.

On*, Off

Secondary Audio Mark

You can set to display the Secondary Audio Mark () when BD with secondary audio is played back.

On*, Off

DivX(R) VOD DRM

You can display registration code for DivX(R) video.

DVD-Audio Mode

Some DVD-Audio discs contain the DVD-Video content in addition to the DVD-Audio content. You can select DVD-Audio mode or DVD-Video mode.

DVD-AUDIO* Both DVD-Audio/Video contents are played back. Only the DVD-Audio content may be played back depending on the disc.

DVD-VIDEO Only the DVD-Video content is played back.

Note

– This setting is only available when no disc is loaded.

Security

Change Password

You can set the password for changing the Parental Control Level and Country Code. Refer to "Parental Control" (p. 31) and "Country Code" (p. 31).

Notes

- The default password is 0000.
- If you forget the password, refer to "TROUBLESHOOTING" (p. 38) and set all the Security settings to their default settings.

Parental Control

In some BD/DVD discs, a control level for disc viewing is set depending on the age of the viewer. You can set the Parental Control shown on the screen depending on the disc content.

The password (see "Change Password" on p. 31) needs to be entered before the Parental Control Levels is set.

After you set the Parental Control, when you play back a disc with level higher than current Parental Control Level, or you want to change the Parental Control Level, a dialog box will pop up to ask you to enter the password.

Off*, 1 to 8

Country Code

You can set the Country Code you live in. The password (see "Change Password" on p. 31) needs to be entered before the Country Code is set. This setting may be used for rating of Parental Control and disc playback.

Network

Internet Connection

Set this item to Enable when you use BD-Live (p. 26), DLNA (p. 21) and software upgrade from the network (p. 37).

Enable*, Disable

Information

You can display network information screen. On this screen, you can view the information of Interface (Ethernet), Address Type, IP Address, Subnet Mask, Default Gateway, and DNS.

Connection Test

You can perform an internet connection test. If the test is failed, please check "IP Setting" (p. 32) and perform the test again.

IP Setting

You can configure the network settings.

- Auto*** Select to automatically configure the network settings of this Player with the DHCP server.
- Manual** Select to configure the network settings (IP Address, Subnet Mask, Default Gateway, and DNS) manually.

Hints

- **Numeric keys** Enters characters.
- **◀▶** Moves the highlight.
- **CLEAR** Deletes a character.
- **ENTER** Saves the settings and exits from the menu.

BD-Live Connection

You can set access restriction to BD-Live contents.

- Permitted** Allows all BD-Live discs to connect the network.
- Partial Permitted*** Allows only discs with owner certification.
- Prohibited** Prohibits all BD-Live discs to connect the network.

DLNA

You can set the DLNA (p. 21) to Enable/Disable. When you do not use the DLNA function, set to Disable.

Enable*, Disable

Proxy Setting

You can set Proxy Setting. Set to Disable for normal use. Set to Enable to set the proxy setting.

- Enable** Enables proxy host and proxy port setting.
- Disable*** Sets proxy server to disable. Select this item when proxy server is not used.
- Proxy Host** Sets proxy host.
- Proxy Port** Sets proxy port.

Display Setting

The default settings are marked with "*".

TV

3D Output

You can select 3D or 2D video output from this Player.

- Auto*** This Player automatically selects 3D or 2D videos.
- Off** This Player always selects 2D videos.

Note

- Even if you set "3D Output" to "Auto" and play back a Blu-ray 3D disc, this Player selects 2D images depending on the connection and the setting of TV, etc (p. 12).



TV Screen

You can set the screen aspect ratio of the connected TV, and adjust the video output.

If you switch your TV (i.e. because you have bought a new one) and the screen aspect ratio of the connected TV changes, you will have to change the TV Screen setting.

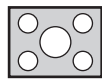
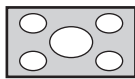
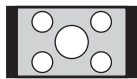
- 16:9 Full** Select this when this Player is connected to a TV with a 16:9 screen. When a 4:3 aspect ratio video is played back, the video is displayed as shown below.
- 16:9 Normal*** Select this when this Player is connected to a TV with a 16:9 screen. When a 4:3 aspect ratio video is played back, the video is displayed as shown below.
- 4:3 Pan Scan** Select this when this Player is connected to a TV with a 4:3 screen. When a 16:9 aspect ratio video is played back, the video is displayed as shown below.
- 4:3 Letterbox** Select this when this Player is connected to a TV with a 4:3 screen. When a 16:9 aspect ratio video is played back, the video is displayed as shown below.

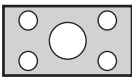
Original image size	On 16:9 (wide screen) TV	
	16:9 Full	16:9 Normal
 4:3		

Original image size	On 4:3 TV	
	4:3 Pan Scan	4:3 Letterbox
 16:9		

Resolution

You can select the video output resolution from Auto, 480i/576i, 480p/576p, 720p, 1080i, and 1080p. When set to Auto, resolution is set to the maximum resolution according to the connected TV. For more details on output formats, refer to “About the video output formats” (p. 36).

Auto*, 480i/576i, 480p/576p, 720p, 1080i, 1080p

Note

- To output HD audio (such as Dolby TrueHD or DTS-HD Master Audio) from HDMI terminal, set Resolution to Auto or more than 720p.

TV System

You can select TV System from PAL, NTSC and Multi. Set the same TV System as your TV set. For more details on output formats, refer to “About the video output formats” (p. 36).

NTSC, PAL*, Multi (Australia, Asia, U.K., Europe and Russia models)

NTSC*, PAL, Multi (U.S.A., Canada, Central and South America, Taiwan and Korea models)

Color Space

You can select the Color Space (p. 41) output from HDMI. This function is available when this Player is connected with an HDMI cable.

RGB Outputs video signal at normal signal range.

YCbCr 4:4:4* Sets Color Space to YCbCr 4:4:4.

YCbCr 4:2:2 Sets Color Space to YCbCr 4:2:2.

Full RGB When RGB is set and white and black on the screen are too faint, select this item. This setting is effective when a connected component supports RGB 0-255 range.

Note

- This function is only available on TVs that support this function.

HDMI Deep Color

When your TV and/or AV receiver is compatible with Deep Color (p. 41), set this item according to your TV/AV receiver. This function is available when this Player is connected with an HDMI cable.

30 bits, 36 bits, Off*

HDMI 1080p 24Hz

This outputs the BD-Video encoded in 24Hz frame rate in HDMI 1080p 24Hz. Smoother video playback may be available with this function. This function is available when your TV/AV receiver support this function, and this Player is connected with an HDMI cable. For more details on output formats, refer to “About the video output formats” (p. 36).

Auto*, Off

Note

- This setting is disabled when output resolution is other than 1080p.

Lip Sync

You can set/adjust the Lip Sync (p. 42) function.

Auto* This Player adjusts the Lip Sync function automatically.

Manual You can adjust the Lip Sync function manually. You can set the delay of the audio for 2D and 3D contents independently.

2D

3D

Off This Player does not adjust the Lip Sync function.

Video Process

Video Mode

You can select Video Mode below.

Standard* The image is most natural and well-balanced. This mode suits for normal use.

Vivid The image is more vivid and sharp.

Cinema The image suits for watching movie in dark room.

Custom You can adjust the visual image manually. Press ▲/▼ to select the parameter, then press ◀/▶ to adjust the figure.

Brightness

Adjusts the overall brightness of the image.

Sharpness

Adjusts the sharpness of objects in the video.

Hue

Adjusts the tint of the projected image.

Saturation

Adjusts the richness of the color in the projected image.

Contrast

Adjusts the bright areas (white levels) in the image.

CTI

Smooths out the edges of color images. Color images are rendered more distinct.

The default settings are 0.

Color Adjust

You can adjust Brightness/Saturation/Hue for each color (Red/Green/Blue/Yellow/Cyan/Magenta). To use this function, set Video Mode to Custom. For details on the setting items, see “Video Mode” (p. 33).

The default settings are 0.

Auto Contrast

Adjusts contrast to optimize the played back image. To use this function, set Video Mode to Custom.

Off*, On

Noise Reduction

You can set the Noise Reduction to a level of 0 to 3. 0 is off, and 3 is the maximum level.

0*, 1, 2, 3

De-interlacing Mode

You can select how to detect the video signal. Set to Auto for normal use. When horizontal stripping noise appears on the screen, set this to Film/Video to remove the noise.

Auto*, Film, Video

■ Audio Setting

The default settings are marked with “*”.

Audio Output

Coaxial/Optical

You can select the output mode of COAXIAL jack and OPTICAL terminal. For more details on output formats, refer to “About the audio output formats” (p. 35).

Bitstream	Outputs digital signal without any processing. Secondary Audio is not output.
PCM	Outputs 2-channel PCM.
Reencode*	Outputs Bitstream with Secondary Audio.
Off	Mutes sound.

HDMI

You can select the output mode of HDMI terminal. For details on setting items, see “Coaxial/Optical” (p. 34). For more details on output formats, refer to “About the audio output formats” (p. 35).

Bitstream*, PCM, Reencode, Off

Note

- To output HD audio (such as Dolby TrueHD or DTS-HD Master Audio) from HDMI terminal, set Resolution to Auto or more than 720p (p. 33).

Downsampling

You can select digital audio signal down-sample frequency. This function is effective for the audio signal output from the COAXIAL jack/OPTICAL terminal.

48k*	The highest sampling rate of digital PCM output is 48 kHz.
96k	The highest sampling rate of digital PCM output is 96 kHz.
192k	The highest sampling rate of digital PCM output is 192 kHz.

DRC

You can set the DRC (Dynamic Range Compression) (p. 41) to on/off/Auto. When set to Auto, DRC is automatically turned on for a source with DRC information in Dolby TrueHD format. DRC makes the strong sound such as plosive sound lower, and conversations more audible. It is useful when you watch movies in the night.

Off*, On, Auto

SACD Output

SACD Priority

You can select a content played back from multi-channel or stereo (2-channel) contents when a Hybrid SA-CD (p. 4) including both is loaded.

Multi-ch*, 2-ch

HDMI Output

You can select audio signal output from HDMI terminal when SA-CD is played back.

DSD*	Outputs DSD raw signal. When this Player is connected to DSD compatible AV receiver, this item is recommended.
PCM	Outputs PCM signal decoded by this Player.

Speaker Setting

Configuration

You can set the output of 7.1 ch surround depending on the connected speaker or amplifier.

- 1 Press **▲/▼** to select a speaker you want to configure, then press **ENTER**.
- 2 Adjust the figures below. Note that some of items are not displayed depend on the selected speaker.

Size	When the woofer section of a speaker is 16 cm (6-1/2 in) or larger, select Large. When smaller than 16 cm (6-1/2 in), select Small.
	Large*, Small
Trim	-12 to 0 dB (in 0.5 dB step)
	The default setting is 0 dB.
Delay	0.5 to 10 m (in 0.5 m step)
	The default setting is 3 m.
Disable	When selected speaker is not in use, select Yes.
	Yes, No*

- 3 Press **RETURN** to go back to speaker selection.

2ch Downmix

You can select down mix method to analog 2-ch from Stereo or Lt/Rt.

Stereo*	Changes channel output to stereo, which only delivers sound from the two front speakers.
Lt/Rt	Select this item if this unit is connected to a Dolby Pro Logic decoder. Sound from rear speakers is mixed to the 2 ch stereo sound.

Post Process

Up Mix

You can multi-channelize the 2-channel audio signal. To multi-channelize, select NEO6, then select Cinema or Music mode.

Off*, NEO6

■ System Information

Software version and MAC address (p. 42) are displayed.

■ About the audio output formats

Source format		HDMI			COAXIAL/OPTICAL			MIXED 2CH/ 7.1 ch surround
		Bitstream	PCM	Reencode	Bitstream	PCM	Reencode	
PCM 2ch		PCM 2ch			PCM 2ch			2ch
PCM 5.1ch		PCM 5.1ch			PCM 2ch			2ch/5.1ch
PCM 7.1ch		PCM 7.1ch			PCM 2ch			2ch/7.1ch
Dolby Digital	with SA* or BCS**	Dolby Digital	PCM up to 5.1ch	Dolby Digital	Dolby Digital	PCM 2ch	Dolby Digital	2ch/5.1ch
Dolby Digital Plus	with SA* or BCS**	Dolby Digital Plus	PCM up to 7.1ch	Dolby Digital Plus	Dolby Digital	PCM 2ch	Dolby Digital	2ch/7.1ch
				Dolby Digital				
Dolby TrueHD	with SA* or BCS**	Dolby TrueHD	PCM up to 7.1ch	Dolby TrueHD	Dolby Digital	PCM 2ch	Dolby Digital	
				Dolby Digital				
DTS	with SA* or BCS**	DTS	PCM up to 5.1ch	DTS	DTS	PCM 2ch	DTS	
DTS HD High Resolution	with SA* or BCS**	DTS HD High Resolution	PCM up to 7.1ch	DTS HD High Resolution	DTS	PCM 2ch	DTS	
				DTS				
DTS-HD Master Audio	with SA* or BCS**	DTS-HD Master Audio	PCM up to 7.1ch	DTS-HD Master Audio	DTS	PCM 2ch	DTS	
				DTS				

* “SA” is a Secondary Audio.

** “BCS” is a button click sound, the sound effect for pop-up menus, etc.

SA-CD output formats

SACD Output settings		HDMI	COAXIAL/OPTICAL	MIXED 2CH/7.1ch surround
SACD Priority	HDMI Output			
Multi-ch	DSD	DSD up to 5.1ch	No output	2ch/5.1ch
	PCM	PCM up to 5.1ch	No output	2ch/5.1ch
2-ch	DSD	DSD 2ch	No output	2ch/2ch
	PCM	PCM 2ch	No output	2ch/2ch

Notes

- When Coaxial/Optical or HDMI is set to Bitstream, secondary audio is not output. (p. 34)
- To output HD audio (such as Dolby TrueHD or DTS-HD Master Audio) from HDMI terminal, set Resolution to Auto or more than 720p (p. 33).
- For SA-CD playback, Configuration in Speaker Setting (p. 34) is effective only when HDMI Output is set to PCM.

■ About the video output formats

When TV System is set to NTSC

	Resolution	Auto	480i/576i	480p/576p	720p	1080i	1080p	
							24Hz	Others
HDMI	Playback BD	Max	Max	Max	720p 60 Hz	1080i 60 Hz	1080p 24 Hz	1080p 60 Hz
	others						1080p 60 Hz	
COMPONENT	Playback commercially-released DVD	480i	480i	480p	480p	480p	480p	
	Playback BD			480i	480i	480i	off	480i
	others			480p	720p 60 Hz *	1080i 60 Hz *	1080i 60 Hz *	
VIDEO	Playback BD	480i	480i	480i	480i	480i	off	480i
	others						480i	

* Depending on the disc or contents, this Player outputs 480p video signal.

When TV System is set to PAL

	Resolution	Auto	480i/576i	480p/576p	720p	1080i	1080p	
							24Hz	Others
HDMI	Playback BD	Max	Max	Max	720p 50 Hz	1080i 50 Hz	1080p 24 Hz	1080p 50 Hz
	others						1080p 50 Hz	
COMPONENT	Playback commercially-released DVD	576i	576i	576p	576p	576p	576p	
	Playback BD			576i	576i	576i	off	576i
	others			576p	720p 50 Hz *	1080i 50 Hz *	1080i 50 Hz *	
VIDEO	Playback BD	576i	576i	576i	576i	576i	off	576i
	others						576i	

* Depending on the disc or contents, this Player outputs 576p video signal.

When TV System is set to Multi

When TV System is set to Multi, video signal is output at the same frequency as the source. Refer to the tables above for details on the frequency setting of the TV and resolution of the output video signal.

While a menu screen such as SETUP menu is displayed, video signal is output at the same frequency as the source.

Notes

- “Max” in the table means that resolution is set to the maximum resolution supported by the connected TV.
- HDMI 1080p 24Hz setting is disabled when output resolution is other than 1080p.
- When this Player outputs the 1080p 24 Hz video signal from HDMI, no signals are output from the COMPONENT and VIDEO jacks.
- When commercially-released DVD is played back with component output, maximum resolution is 480p/576p.
- When TV System is set to NTSC and video source is not 60 Hz, the video output signal is converted to 60 Hz.
- When TV System is set to PAL and video source is not 50 Hz, the video output signal is converted to 50 Hz.

SOFTWARE UPGRADE

Some of the newly released BD discs cannot be played back unless you upgrade this Player software to the latest version. We recommend upgrading the software of this Player with software upgrade so that this Player is operated based on the latest software.

To check for the availability of a software upgrade, visit

<http://download.yamaha.com/downloads/service/top/?site=europe.yamaha.com&language=en>

Hint

- Software upgrade is automatically started after loading the disc which contains upgrade file package.

Note

- Do not remove the disc/USB memory device, set this Player to standby mode or unplug the power cable/LAN cable while the software upgrade is being performed.

■ Upgrading the software

1. Prepare for the software upgrade.

When you upgrade the software from Disc/USB Storage:

- ① Save the upgrade file package to the appropriate folder on the disc/USB memory device. For more details, refer to the procedure document attached with the upgrade file package.
- ② Load the disc or connect the USB memory device.
When the disc is loaded, software upgrade is started automatically. Skip step 2.

When you upgrade the software from Network:
Confirm that this Player is connected to the network.

2. Select the upgrade method and start upgrade from SETUP menu.

- ① Press **SETUP** to display SETUP menu screen.
- ② Select General Setting → System → Upgrade.

- ③ Select the item which contains the upgrade file package from Disc/USB Storage/Network.

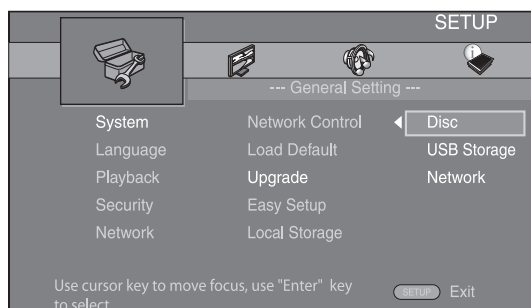

3. The system will search for upgrade file package.

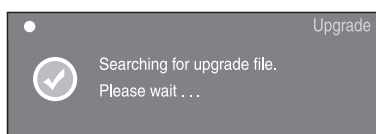

4. Press ENTER to start upgrade.

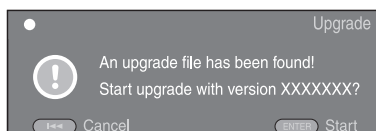

5. Upgrade is completed. The system will restart.





TROUBLESHOOTING

Refer to the table below when this Player does not function properly. If the problem you are experiencing is not listed below or if the instruction below does not help, turn off this Player, disconnect the power cable, and contact the nearest authorized Yamaha dealer or service center.

■ Power

Problem	Possible causes and solutions
No power.	<ul style="list-style-type: none"> – Connect the AC power cable properly. – Press  on the front panel to turn on the power.
The Player power is turned off.	<ul style="list-style-type: none"> – The power will be automatically turned off after 10 continuous minutes of inactivity (no playback).

■ Basic operation

Problem	Possible causes and solutions
The remote control does not work.	<ul style="list-style-type: none"> – Use the remote control within its operating range. (p. 5) – Replace the batteries. (p. 5) – Check the ID settings for the main unit and the remote control. (p. 9)
Buttons do not work.	<ul style="list-style-type: none"> – Press and hold  on the front panel for around 5 seconds to restart this Player. – To completely reset this Player, unplug the power cable from the AC outlet for 10 seconds or more, plug the power cable to the AC outlet again, and then turn on this Player.
Password is forgotten.	<ul style="list-style-type: none"> – Press and hold  and  on the front panel simultaneously when no disc is inserted and playback is stopped to set the Player to default setting (Security setting (p. 31) is also reset). After the power is turned off automatically, press  to turn on the power again.

■ Disc playback

Problem	Possible causes and solutions
The Player cannot play a disc.	<ul style="list-style-type: none"> – Take out the disc and clean it. (p. 4) – Make sure that the disc is loaded properly (aligned in disc tray and label-side up). (p. 4) – Use a disc supported by the Player. (p. 3) – Remove the disc and then check whether the Player supports the disc or not. (p. 3) – Check the region code. (p. 3) – Check whether the disc is defective by trying another disc. – The CD-R/RW, DVD+R/RW/R DL, and DVD-R/RW/R DL must be finalized. (p. 3)
Video stops.	<ul style="list-style-type: none"> – The Player will stop if it senses shock or vibration.
The Player makes a snapping sound when starting playback or loading a disc.	<ul style="list-style-type: none"> – These sounds are not malfunctions of the Player but are normal operating conditions.

■ Picture

Problem	Possible causes and solutions
No picture.	<ul style="list-style-type: none"> – Make sure that the cables are connected correctly. (p. 10) – Make sure that the connected TV or the AV receiver is set to the correct input. (p. 10) – Connect this Player to the TV with VIDEO jack (p. 13) using the supplied video pin cable and set Resolution properly. (p. 33) – TV System is set to the incorrect setting. Press and hold DIMMER on the remote control to reset TV System setting to default setting.
Screen freezes and operation buttons do not work.	<ul style="list-style-type: none"> – Press ■, then restart playback. – Turn off the power and turn on the power again. – Press and hold ⏻ on the front panel for around 5 seconds to restart this Player.
Video is not output with the desired resolution.	<ul style="list-style-type: none"> – Set to the desired resolution. (p. 33)
Widescreen video appears vertically stretched, or black bands appear at the top and bottom of the screen. Or 4:3 video appears horizontally stretched.	<ul style="list-style-type: none"> – Change the aspect ratio of your TV. (p. 32)
Square noise (mosaic) appears on the screen.	<ul style="list-style-type: none"> – Blocks in images may be visible in scenes with rapid movement due to the characteristics of digital image compression technology.
The playback screen will be disturbed if DVD video is recorded to a VCR, or played back through a VCR.	<ul style="list-style-type: none"> – This Player complies with analog copy protection. Some discs contain a copy prohibiting signal. If you try to play back such discs through a VCR, or record to a VCR and play back the signal, the copy protection will prevent normal playback.
Audio is not output, or images are not played back properly.	<ul style="list-style-type: none"> – The audio may not be output or the images may not be played back properly for some discs in which copyright-protected contents are recorded.

■ Sound

Problem	Possible causes and solutions
No sound, or sound is distorted.	<ul style="list-style-type: none"> – Check that the audio cable is connected correctly. (p. 10) – There is no sound during still mode, slow motion playback, fast forward and fast reverse. (p. 7) – Audio may not be output depending on the audio recording status, such as when audio other than an audio signal or non-standard audio is recorded for the audio content. (p. 3)
Left and right channels of audio are reversed, or sound comes out of only one side.	<ul style="list-style-type: none"> – Check the audio connection. (p. 10)
Audio is not output, or images are not played back properly.	<ul style="list-style-type: none"> – The audio may not be output or the images may not be played back properly for some discs in which copyright-protected contents are recorded.
Cannot hear the desired audio type and/ or number of channels.	<ul style="list-style-type: none"> – Refer to Audio Output setting and “About the audio output formats”. (p. 34, 35)
Cannot hear the sound of PIP (secondary audio).	<ul style="list-style-type: none"> – Set Coaxial/Optical or HDMI to PCM/Reencode. (p. 34) – To hear secondary audio, press 2ND AUDIO. (p. 6) – Depending on the disc, you may need to set secondary audio on the top menu of the disc. (p. 7)

■ Network

Problem	Possible causes and solutions
Cannot connect to the Internet.	<ul style="list-style-type: none"> – Connect the Network cable properly. – Turn on the connected equipment, such as broadband router or modem. – Connect the broadband router and/or modem properly. – Set the proper value(s) in the network setting. Check “Network”. (p. 32)
Cannot download BD-Live contents.	<ul style="list-style-type: none"> – Connect the Network cable properly. (p. 16) – Connect USB memory device properly. Check that the USB memory device is connected to the USB port of this Player. (p. 16) – Check if the BD disc supports BD-Live. – Check the setting for “Internet Connection”. (p. 32) – Connect the USB memory device formatted in FAT16 or FAT32. – It is recommended to connect the USB memory device with at least 2 GB of free space. If there is not enough free space, format the USB memory device. (p. 30) – Refer to the supplied user's manual of the disc or consult the disc manufacturer.
Cannot detect the DLNA server.	<ul style="list-style-type: none"> – Connect the network cable properly. – Turn on the connected equipment, such as broadband router or the server. – Confirm the Player and the server are connected to the same access point. – Set the proper value(s) in the network setting. Check “Network”. (p. 32) – Depending on the DLNA server, the Player may need to be permitted from the server.
Cannot a play the file on the home network server.	<ul style="list-style-type: none"> – Make sure the file is playable. (p. 3) – Check your DLNA server's setting. – The playback and operating quality may be affected by your home network condition.

■ Messages on the screen

- The following messages appear on the TV screen in case the disc you tried to play back is not appropriate or the operation is not correct.

Error message	Possible causes and solutions
Not Support This File!	– The file is not supported with this Player. See “Types of discs/files that can be used with this Player” (p. 3).
Wrong region code!	– The disc is an incompatible region code. See “Region management information” (p. 3).
Network has FAILED.	– This Player cannot be connected to the network. Check connection (p. 16) and Network setting (p. 32).
Network is OK, proxy has FAILED.	– This Player cannot be connected to the proxy server. See “Proxy Setting” (p. 32).
The Setting is prohibited, please setup again.	– BD-Live connection is prohibited. See “BD-Live Connection” (p. 32).
No valid upgrade file is found!	– Check if the upgrade file is in the appropriate folder.
Upgrade has failed for some reason!	– Upgrade is failed. Check if the upgrade file is corrupted or unreadable.

GLOSSARY

AVCHD

AVCHD is a new format (standard) for high definition video cameras that can be used to record and play high-resolution HD images.

BD-Live™

BD-Live is a BD standard that utilizes a network connection, enabling this Player to go online to download promotional videos and other data.

BDMV

BDMV (Blu-ray Disc Movie, BD-MV) refers to one of the application formats used for BD-ROM which is one of the Blu-ray Disc specifications. BDMV is a recording format equivalent to DVD-Video of the DVD specification.

Blu-ray 3D™

Blu-ray 3D enables you to view full high definition 3D images.

BONUSVIEW

BONUSVIEW compatible discs let you simultaneously enjoy video sub-channel for two screens, audio sub-channel and sub-titles. A small screen appears within the main screen during playback (Picture in Picture).

Closed caption

Closed captions are kind of subtitle, and the difference between subtitles and captions is that subtitles are intended for hearing persons and captions are for the hearing impaired. Subtitles rarely show all of the audio. For example, captions show sound effects (e.g., “phone ringing” and “footsteps”), while subtitles do not. Before you select this setting, please ensure that the disc contains closed caption information.

Color Space

Color Space is a color range that can be represented. RGB is a color space based on the RGB color model (red, green and blue) and is typically used for PC monitors. YCbCr is a color space based on a luminance signal (Y) and two color difference signals (Cb and Cr).

Deep Color

Deep Color refers to the use of various color depths in displays, up from the 24-bit depths in previous versions of the HDMI specification. This extra bit depth allows HDTVs and other displays go from millions of colors to billions of colors and eliminate on-screen color banding for smooth tonal transitions and subtle gradations between colors. The increased contrast ratio can represent many times more shades of gray between black and white. Also Deep Color increases the number of available colors within the boundaries defined by the RGB or YCbCr color space.

DivX®

DivX® is a popular media technology created by DivX, Inc. DivX® media files contain highly compressed video with high visual quality that maintains a relatively small file size. DivX® files can also include advanced media features like menus, subtitles, and alternate audio tracks. Many DivX® media files are available for download online, and you can create your own using your personal content and easy-to-use tools from DivX.com.

Dolby Digital

A sound system developed by Dolby Laboratories Inc. that gives movie theater ambience to audio output when the product is connected to a Dolby Digital processor or amplifier.

Dolby Digital Plus

A sound system developed as an extension to Dolby Digital. This audio coding technology supports 7.1 multi-channel surround sound.

Dolby TrueHD

Dolby TrueHD is a lossless coding technology that supports up to 8 channels of multi-channel surround sound for the next generation optical discs. The reproduced sound is true to the original source bit-for-bit.

DRC (Dynamic Range Control)

DRC lets you adjust the range between the loudest and softest sounds (dynamic range) for playback at average volume. Use this when it is hard to hear dialog, or during times when playback may disturb neighbors.

DSD (Direct Stream Digital)

DSD technology stores audio signals on digital storage media, such as Super Audio CDs. Using DSD, signals are stored as single bit values at a high-frequency sampling rate of 2.8224 MHz, while noise shaping and oversampling are used to reduce distortion, a common occurrence with very high quantization of audio signals. Due to the high sampling rate, better audio quality can be achieved than that offered by the PCM format used for normal audio CDs.

DTS

This is a digital sound system developed by DTS, Inc. for use in cinemas.

DTS-HD High Resolution Audio

DTS-HD High Resolution Audio is a new technology developed for the next generation high definition optical disc format.

DTS-HD Master Audio

DTS-HD Master Audio is a lossless audio compression technology developed for the next generation high definition optical disc format.

DTS-HD Master Audio | Essential

DTS-HD Master Audio | Essential is a lossless audio compression technology developed for the next generation high definition optical disc format.

HDMI

HDMI (High-Definition Multimedia Interface) is an interface that supports both video and audio on a single digital connection. The HDMI connection carries standard to high definition video signals and multi-channel audio signals to AV components such as HDMI equipped TVs, in digital form without degradation.

Letterbox (LB 4:3)

A screen size with black bars on the top and bottom of the image to allow viewing of wide-screen (16:9) material on a connected 4:3 TV.

Linear PCM Sound

Linear PCM is a signal recording format used for Audio CDs and on some DVD and Blu-ray discs. The sound on Audio CDs is recorded at 44.1 kHz with 16 bits. (Sound is recorded between 48 kHz with 16 bits and 96 kHz with 24 bits on DVD discs and between 48 kHz with 16 bits and 192 kHz with 24 bits on BD discs.)

Lip Sync

Lip Sync, an abbreviation for lip synchronization, is a technical term that involves both a problem and a capability of maintaining audio and video signals synchronized during post-production and transmission. Whereas the audio and video latency requires complex end-user adjustments, HDMI version 1.3 incorporates an automatic audio and video syncing capability that allows devices to perform this synchronization automatically and accurately without user interaction.

Mac address

The Mac address is a unique value assigned to a network device for identification purposes.

Pan Scan (PS 4:3)

A screen size that cuts off the sides of the image to allow viewing of wide-screen (16:9) material on a connected 4:3 TV.

Subtitles

These are the lines of text appearing at the bottom of the screen which translate or transcribe the dialog. They are recorded on many DVD and BD discs.

Top menu

In a BD-Video/DVD-Video, this is the menu for selecting things like the chapter to be played back and the subtitle language. In some DVD-Videos, the top menu may be called the "Title Menu".

x.v.Color

x.v.Color reproduces a greater range of color than before, showing almost all of the colors that the human eye can detect.

SPECIFICATIONS

■ General

Power supply	
[U.S.A. and Canada models].....	AC 110-240 V, 60 Hz
[Central and South America models].....	AC 110-240 V, 50/60 Hz
[Europe and Russia models]	AC 230 V, 50 Hz
[Australia model]	AC 110-240 V, 50 Hz
[Asia model].....	AC 220-240 V, 50/60 Hz
[Taiwan model].....	AC 110-120 V, 50/60 Hz
[Korea model]	AC 220 V, 60 Hz
Power consumption (Normal)	25 W
Power consumption (Standby)	0.5 W or less
Dimensions (W × H × D)	435 × 96 × 316 mm
	(17-1/8 × 3-3/4 × 12-1/2 in)
Weight	4.05 kg (8.93 lbs.)

■ Audio performance

Audio output level (1 kHz, 0 dB, BD/DVD/CD-DA).....	± 0.3 V
Signal to noise ratio (BD/DVD/CD-DA)	115 dB or more
Dynamic range	
BD/DVD	105 dB or more
CD-DA	100 dB or more
Harmonic distortion (1 kHz)	
BD/DVD	0.0028 % or less
CD-DA	0.003 % or less
Frequency response	
BD/DVD	2 Hz to 22 kHz (48 kHz Sampling)
	2 Hz to 44 kHz (96 kHz Sampling)
CD-DA	2 Hz to 20 kHz

■ Input/output

HDMI output	Type A connector × 1
	480i/576i/480p/576p/720p/1080i/1080p/1080p@24Hz,
	Deep Color, x.v. Color support
Component video output	Y: 1 Vp-p (75 ohms)
	Pb, Pr: 0.7 Vp-p (75 ohms)
Video output	1 Vp-p (75 ohms)
Digital output	Optical × 1, Coaxial × 1
Analog audio output	7.1 ch × 1,
	Mixed 2 ch × 1
USB	Type A connector × 2
Other equipments	Remote IN/OUT × 1,
	RS-232C × 1 (for custom installer),
	Ethernet × 1

Specifications are subject to change without notice.

■ Copyright

- Audio-visual material may consist of copyrighted works which must not be recorded without the authority of the owner of the copyright. Refer to relevant laws in your country.
- This item incorporates copy protection technology that is protected by U.S. patents and other intellectual property rights of Rovi Corporation. Reverse engineering and disassembly are prohibited.
- Manufactured under license from Dolby Laboratories. Dolby and the double-D symbol are trademarks of Dolby Laboratories.
- Manufactured under license under U.S. Patent #'s: 5,451,942; 5,956,674; 5,974,380; 5,978,762; 6,226,616; 6,487,535; 7,212,872; 7,333,929; 7,392,195; 7,272,567 & other U.S. and worldwide patents issued & pending. DTS and the Symbol are registered trademarks, & DTS-HD, DTS-HD Master Audio, and the DTS logos are trademarks of DTS, Inc. Product includes software. © DTS, Inc. All Rights Reserved.
- “Blu-ray Disc™”, “Blu-ray™”, “Blu-ray 3D™”, “BD-Live™”, “BONUSVIEW™”, and the logos are trademarks of the Blu-ray Disc Association.
-  is a trademark of DVD Format/Logo Licensing Corporation.
- HDMI, the HDMI logo and High-Definition Multimedia Interface are trademarks or registered trademarks of HDMI Licensing LLC.
- “x.v.Color” and “x.v.Color” logo are trademarks.
- “AVCHD” and the “AVCHD” logo are trademarks of Panasonic Corporation and Sony Corporation.
- Java and all Java-based trademarks and logos are trademarks or registered trademarks of Sun Microsystems, Inc. in the United States and/or other countries.
- This product is licensed under the AVC patent portfolio license and VC-1 patent portfolio license for the personal and non-commercial use of a consumer to (i) encode video in compliance with the AVC Standard and VC-1 Standard (“AVC/VC-1 Video”) and/or (ii) decode AVC/VC-1 Video that was encoded by a consumer engaged in a personal and non-commercial activity and/or was obtained from a video provider licensed to provide AVC/VC-1 Video. No license is granted or shall be implied for any other use. Additional information may be obtained from MPEG LA, LLC. See <http://www.mpegla.com>.
- Windows Media Player is a registered trademark or trademark of Microsoft corporation in the United States and/or other countries.
- DLNA and DLNA CERTIFIED are trademarks and/or service marks of Digital Living Network Alliance.
- YouTube and the YouTube logo are trademarks of Google. Inc.
- “DivX®, DivX Certified®, DivX Plus™ HD and associated logos are registered trademarks of DivX, Inc. and are used under license.”
- “DivX Certified® to play DivX® and DivX Plus™ HD (H.264/.MKV) video up to 1080p HD and premium content.”

ABOUT DIVX VIDEO: DivX® is a digital video format created by DivX, Inc. This is an official DivX Certified® device that plays DivX video. Visit divx.com for more information and software tools to convert your files into DivX video.

ABOUT DIVX VIDEO-ON-DEMAND: This DivX Certified® device must be registered in order to play purchased DivX Video-on-Demand (VOD) movies. To obtain your registration code, locate the DivX VOD section in your device setup menu. Go to vod.divx.com for more information on how to complete your registration.

PRECAUCIÓN: LEA LAS INDICACIONES SIGUIENTES ANTES DE UTILIZAR ESTE APARATO

- 1 Para asegurar el mejor rendimiento de este aparato, lea atentamente este manual. Y luego guárdelo en un lugar seguro para poder consultarlo en el futuro en caso de ser necesario.
- 2 Instale esta unidad en un lugar bien ventilado, fresco, seco y limpio, alejado de la luz directa del sol, fuentes de calor, vibración, polvo, humedad y/o frío. Para una adecuada ventilación, permita que el equipo tenga el siguiente espacio libre mínimo:
Superior: 10 cm
Posterior: 10 cm
Laterales: 10 cm
- 3 Coloque este aparato lejos de otros aparatos eléctricos, motores o transformadores, para evitar así los ruidos de zumbido.
- 4 No exponga este aparato a cambios bruscos de temperaturas, del frío al calor, ni lo coloque en lugares muy húmedos (una habitación con deshumidificador, por ejemplo), para impedir así que se forme condensación en su interior, lo que podría causar una descarga eléctrica, un incendio, daños en el aparato y/o lesiones a las personas.
- 5 Evite instalar este aparato en un lugar donde puedan caer encima objetos extraños y/o donde quede expuesto al goteo o a la salpicadura de líquidos. Encima de este aparato no ponga:
 - Otros componentes, porque pueden causar daños y/o decoloración en la superficie de este aparato.
 - Objetos con fuego (velas, por ejemplo), porque pueden causar un incendio, daños en el aparato y/o lesiones a las personas.
 - Recipientes con líquidos, porque pueden caer y derramar el líquido, causando descargas eléctricas al usuario y/o dañando el aparato.
- 6 No tape este aparato con un periódico, mantel, cortina, etc. para no impedir el escape del calor. Si aumenta la temperatura en el interior del aparato, esto puede causar un incendio, daños en el aparato y/o lesiones a las personas.
- 7 No enchufe este aparato a una toma de corriente hasta después de haber terminado todas las conexiones.
- 8 No ponga el aparato al revés. Podría recalentarse y posiblemente causar daños.
- 9 No utilice una fuerza excesiva con los conmutadores, los controles y/o los cables.
- 10 Cuando desconecte el cable de alimentación de la toma de corriente, sujete la clavija y tire de ella; no tire del propio cable.
- 11 No limpie este aparato con disolventes químicos porque podría estropear el acabado. Utilice un paño limpio y seco para limpiar el aparato.
- 12 Utilice solamente la tensión especificada en este aparato. Utilizar el aparato con una tensión superior a la especificada resulta peligroso y puede producir un incendio, daños en el aparato y/o lesiones a las personas. Yamaha no se hará responsable de ningún daño debido al uso de este aparato con una tensión diferente de la especificada.
- 13 Para impedir daños debidos a relámpagos, desconecte el cable de alimentación de la toma de corriente durante una tormenta eléctrica.
- 14 No intente modificar ni arreglar este aparato. Póngase en contacto con el personal de servicio Yamaha cualificado cuando necesite realizar alguna reparación. La caja no deberá abrirse nunca por ninguna razón.
- 15 Cuando no piense utilizar este aparato durante mucho tiempo (cuando se ausente de casa por vacaciones, por ejemplo) desconecte el cable de alimentación de la toma de corriente.
- 16 Asegúrese de leer la sección “RESOLUCIÓN DE PROBLEMAS” antes de dar por concluido que su aparato está averiado.
- 17 Antes de trasladar este aparato, pulse  para ponerlo en el modo de espera, y luego desconecte el cable de alimentación de CA de la toma de corriente.
- 18 La condensación se formará cuando cambie de repente la temperatura ambiental. Desconecte en este caso el cable de alimentación de la toma de corriente y no utilice el aparato.
- 19 El aparato se calentará cuando la utilice durante mucho tiempo. Desconecte en este caso la alimentación y luego no utilice el aparato para permitir que se enfríe.
- 20 Instale este aparato cerca de la toma de CA y donde se pueda alcanzar fácilmente la clavija de alimentación.
- 21 Las baterías no deberán exponerse a un calor excesivo como, por ejemplo, el que producen los rayos del sol, el fuego y similares.

Este aparato no se desconecta de la fuente de alimentación de CA si está conectada a una toma de corriente, aunque la propia aparato esté apagada con . A este estado se le llama modo de espera. En este estado, este aparato ha sido diseñada para que consuma una cantidad de corriente muy pequeña.

ADVERTENCIA
PARA REDUCIR EL RIESGO DE INCENDIO O DESCARGA ELÉCTRICA, NO EXPONGA ESTE APARATO A LA LLUVIA NI A LA HUMEDAD.

El componente láser de este producto es capaz de emitir radiación que sobrepasa el límite establecido para la clase 1.

PRECAUCIÓN
El uso de los controles, los ajustes o los procedimientos que no se especifican en este manual pueden causar una exposición peligrosa a la radiación.

Especificaciones LÁSER:
Producto LÁSER de Clase 1
Longitud de onda: 790 nm (CD)/655 nm (DVD)/405 nm (BD)
Salida de láser: máxima de 1 mW

SEGURIDAD CONTRA LA RADIACIÓN LÁSER
Este aparato utiliza rayos láser. Debido a la posibilidad de que se produzcan daños en los ojos, la extracción de la cubierta del aparato o las reparaciones solamente deberán ser realizadas por un técnico cualificado.

PELIGRO
Este aparato emite radiación láser visible cuando se abre. Evite la exposición directa a los rayos láser. Cuando se conecte este aparato a una toma de corriente no acerque sus ojos a la abertura de la bandeja del disco ni a otras aberturas para mirar al interior.

CONTENIDO

1

1. INTRODUCCIÓN

QUÉ PUEDE HACER CON ESTE REPRODUCTOR	2
PIEZAS INCLUIDAS	2
INFORMACIÓN SOBRE DISCOS Y ARCHIVOS	3
Tipos de discos/archivos que se pueden utilizar con este reproductor	3
Para cargar un disco	4
Precauciones con los discos	4
CONTROLES Y FUNCIONES	5
Panel delantero	5
Mando a distancia	6

2. CONEXIONES

INTRODUCCIÓN A LAS CONEXIONES	10
Panel trasero	10
HDMI CONEXIONES	12
Conexión con el terminal HDMI	12
Conexión para la reproducción de discos 3D de Blu-ray	12
CONEXIONES DE VÍDEO	13
Conexión a la toma de vídeo componente	13
CONEXIONES DE AUDIO	14
Conexión con el terminal/toma de audio digital	14
Conexión con las tomas de audio	15
CONEXIÓN DE RED Y USB	16
Conexión con el terminal NETWORK y el puerto USB	16
OTRAS CONEXIONES	17
Conexión a las tomas REMOTE CONTROL	17
Conexión del cable de alimentación	17

3. REPRODUCCIÓN

ASISTENTE INICIAL/CONFIGURACIÓN SENCILLA	18
Configuración con el Asistente inicial/Configuración Sencilla	18
MENÚ HOME/MEDIA	19
Reproducción de Foto/Música/Vídeo	19
Uso del contenido de red	21
USO DE SERVICIOS DE RED	22
REPRODUCCIÓN DE VÍDEOS DESDE YouTube™	22
FUNCIONAMIENTO DE REPRODUCCIÓN AVANZADO	23
Menú en pantalla	23
Menú de estado	24
Uso de Marcador	25
Reproducción de programa	25
Uso de la búsqueda	25
Disfrute de BONUSVIEW™ y BD-Live™	26
Utilización de la función Imagen en Imagen (reproducción de audio/vídeo secundario)	26
Utilización de la función de BD-Live™	26

4. AJUSTES

MENÚ SETUP	27
Ejemplo de funcionamiento del menú SETUP	29
Configuración General	30

Configuración de pantalla	32
Configuración de audio	34
Sistema de Información	34
Formatos de salida de audio	35
Acerca de los formatos de salida de vídeo	36
ACTUALIZACIÓN DE SOFTWARE	37
Actualización del software	37

5. INFORMACIÓN ADICIONAL

RESOLUCIÓN DE PROBLEMAS	38
Alimentación	38
Funcionamiento básico	38
Reproducción de disco	38
Imagen	39
Sonido	39
Red	40
Mensajes en pantalla	40
GLOSARIO	41
ESPECIFICACIONES	42
Generalidades	42
Rendimiento de audio	42
Entrada/salida	42
Propiedad intelectual	43

(al final de este manual)

Information about software	i
----------------------------------	---

2

3

4

5

■ Acerca de este manual

- Este manual describe cómo utilizar este reproductor con un mando a distancia, excepto cuando no esté disponible. También se puede acceder a algunas de estas operaciones mediante los botones del panel delantero.
- Las notas contienen información importante sobre seguridad e instrucciones de funcionamiento. Las indicaciones señalan consejos de funcionamiento.
- Este manual se ha impreso antes de la fabricación. El diseño y las especificaciones están sujetos a cambios en parte como resultado de mejoras, etc. En caso de diferencias entre el manual y el producto, este último tiene prioridad.

Iconos utilizados en este manual

Los iconos se utilizan para indicar botones/funciones disponibles para un formato particular.

BD	: Vídeo BD
DVD	: Vídeo DVD, DVD-VR, DVD+VR, DVD-Audio
CD	: Audio CD, Super Audio CD
VIDEO	: AVCHD, WMV, DivX
MUSIC	: MP3, WMA, WAV
PHOTO	: JPEG

Español

QUÉ PUEDE HACER CON ESTE REPRODUCTOR

Configuración sencilla de idioma, resolución, relación de aspecto de la pantalla → pág. 18

Puede ajustar la configuración de idioma y TV.

Reproducción de discos Blu-ray™/DVD/CD/SA-CD/DVD-Audio lanzados comercialmente* → pág. 23

Además de Blu-ray Discs™ (discos BD), este reproductor también admite la reproducción de otros discos diversos.

Reproducción de BONUSVIEW™, BD-Live™, etc.* → pág. 26

Puede disfrutar de películas adicionales en los discos BD más recientes.

Reproducción de archivos de Vídeo, Música, Foto de un disco* → pág. 19

Este reproductor puede reproducir los discos que usted grabe.

Reproducción de archivos de Vídeo, Música, Foto de un disco/ dispositivos de memoria USB* → pág. 19

Con este reproductor se pueden reproducir archivos grabados en discos/dispositivos de memoria USB.

Reproducción de archivos de Vídeo, Música, Foto de un servidor doméstico de red* ** → pág. 21

El contenido del PC se puede reproducir en el televisor o el receptor de A/V conectando este reproductor a un servidor de red.

Funcionamiento con el mando a distancia del televisor, receptor de A/V, etc. → pág. 30

Puede conectar dispositivos con un cable HDMI y controlarlos con un único mando a distancia utilizando la función Control HDMI.

Transferencia de contenidos de reproducción en los servicios de red** → pág. 22

Puede disfrutar instantáneamente de vídeos a través de Internet con este reproductor.

* Para conocer los detalles sobre los discos y formatos que se pueden reproducir, consulte la página 3.

** Para utilizar esta función es necesaria la configuración de red.

PIEZAS INCLUIDAS

Asegúrese de que con el producto se han suministrado los siguientes accesorios.

Mando a distancia



Pilas (x2)
(AAA, R03, UM-4)

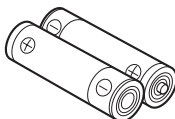

Cable de clavijas de audio

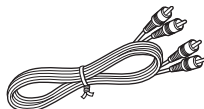

Cable de clavijas de vídeo

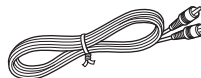



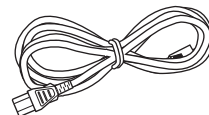







Cable de alimentación









Tipos de discos/archivos que se pueden utilizar con este reproductor

- En este reproductor se pueden reproducir discos de 12 cm y 8 cm. No utilice un adaptador de 8 cm a 12 cm.
- Utilice discos que sean compatibles con los estándares que se indican con la presencia de logotipos oficiales marcados en la etiqueta del disco. La reproducción de discos que no cumplan con estos estándares no está garantizada. Además, la calidad de imagen o sonido no está garantizada incluso si tales discos se pueden reproducir.

Tipo de disco	Formato de grabación	Formato de datos
BD-ROM/BD-R/ BD-RE	Vídeo BD	--
DVD-ROM	Vídeo DVD/DVD-Audio	--
DVD-R/DVD-R DL/ DVD-RW	Vídeo DVD/DVD-VR/AVCHD/disco de datos	DivX/WMV/MP3/ WAV/WMA/JPEG
DVD+R/DVD+R DL/DVD+RW	Vídeo DVD/ DVD+VR/AVCHD/ disco de datos	DivX/WMV/MP3/ WAV/WMA/JPEG
CD-ROM	CDDA/HDCD	--
CD-R/CD-RW	CDDA/disco de datos	DivX/WMV/MP3/ WAV/WMA/JPEG
SA-CD	SA-CD	--
USB	--	DivX/WMV/MP3/ WAV/WMA/JPEG
Red	--	WMV/MP3/WMA/ WAV/JPEG

Información de gestión de la región		
Destino	Vídeo BD	Vídeo DVD
Corea	Código de región "A" o "ALL" 	Número de región "3" o "ALL" 
América Central y del Sur	Código de región "A" o "ALL" 	Número de región "4" o "ALL" 
Europa	Código de región "B" o "ALL" 	Número de región "2" o "ALL" 
Australia	Código de región "B" o "ALL" 	Número de región "4" o "ALL" 
Rusia	Código de región "C" o "ALL" 	Número de región "5" o "ALL" 

Información de gestión de la región		
Destino	Vídeo BD	Vídeo DVD
EE.UU. y Canadá	Código de región "A" o "ALL" 	Número de región "1" o "ALL" 
Asia	Código de región "A" o "ALL" 	Número de región "3" o "ALL" 
Taiwán	Código de región "A" o "ALL" 	Número de región "3" o "ALL" 

- Los discos y los reproductores de vídeo BD/DVD tienen códigos de región que dictan las regiones en las que se puede reproducir un disco.
- Las operaciones y funciones de vídeo BD/DVD pueden ser diferentes de las explicaciones que aparecen en este manual y algunas operaciones pueden estar prohibidas debido a las configuraciones del fabricante del disco.
- Si se visualiza una pantalla de menú o instrucciones de funcionamiento durante la reproducción de un disco, siga el procedimiento de funcionamiento visualizado.

Notas

- Según el disco, puede que no sea posible la reproducción de algunos de los discos de las tablas de la columna izquierda.
- Finalice todos los medios de reproducción que se reproduzcan en este reproductor.
- "Finalizar" hace referencia a un procesamiento del grabador sobre un disco grabado para que se pueda reproducir en otros reproductores/grabadores, así como en este reproductor. Sólo se podrán reproducir en el reproductor los discos que se hayan finalizado. (Este reproductor no dispone de función para finalizar discos.)
- No se garantiza la reproducción de todos los archivos del disco, dispositivo de memoria USB y red.

- Un archivo con propiedad intelectual protegida no se puede reproducir a través de un dispositivo de memoria USB o red.

Requisitos de archivos de audio MP3/WMA/WAV

- Frecuencia de muestreo: entre 32 – 48 kHz (MP3/WMA), LPCM 44,1 kHz/16 bits/estéreo (WAV)
- Bitrate: entre 8 – 320 kbps (MP3), 32 – 192 kbps (WMA)

Requisitos de archivo WMV

- WMV9, la resolución máxima es 1.920 × 1.080.

Acerca de Super Audio CD (SA-CD)

- Formato de audio basado en los estándares actuales de CD pero con mayor cantidad de información, lo que se traduce en un sonido de una calidad superior. Existen tres tipos de discos: de una capa, de doble capa e híbridos. El disco híbrido puede reproducirse en los reproductores de CD existentes y en los reproductores de Super Audio CD, ya que contiene información de CD de audio estándar y de Super Audio CD.

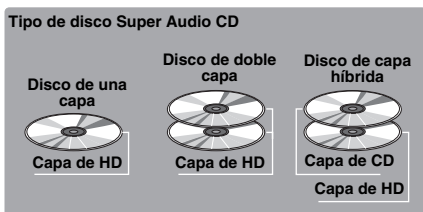

Consejo

- Este reproductor admite la transmisión de datos DSD a través de HDMI con un receptor A/V compatible.

Nota

- Esta unidad no muestra los datos de texto incluidos en los discos en el visor del panel delantero.

■ Para cargar un disco

- Inserte el disco con la etiqueta hacia arriba.
- En el caso de un disco grabado por ambos lados, ponga boca abajo el lado que va a reproducir.

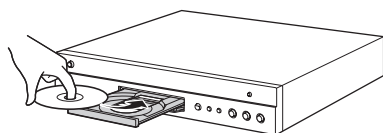

Notas





- La reproducción podría iniciarse automáticamente, dependiendo del disco y la configuración del reproductor.
- El menú podrá visualizarse primero, según el disco.
- El tiempo para cargar el disco puede variar dependiendo del disco.

■ Precauciones con los discos

Tenga cuidado con los arañazos y el polvo

- Los discos BD, DVD y CD son sensibles al polvo, a las huellas dactilares y especialmente, a los arañazos. Es posible que no se pueda reproducir un disco con arañazos. Maneje los discos con cuidado y almacénelos en un lugar seguro.

Almacenamiento apropiado de los discos

Ponga el disco en el centro de la caja y almacene la caja y el disco en posición vertical.	
Evite guardar los discos en lugares con luz solar directa, cerca de dispositivos de calefacción o en lugares con alta humedad.	
No deje caer los discos ni los someta a vibraciones o impactos fuertes.	
Evite almacenar los discos en lugares donde haya mucha cantidad de polvo o humedad.	

Precauciones para el manejo



- Si la superficie tiene manchas, límpiela suavemente con un paño suave humedecido (con agua solamente). Cuando limpie los discos, mueva siempre el paño desde el orificio central hacia el borde exterior.
- No utilice pulverizadores de limpieza de discos de vinilo, bencina, diluyente, líquidos para prevención de electricidad estática u otros disolventes.
- No toque la superficie.
- No adhiera papel ni etiquetas adhesivas en el disco.
- Si la superficie de reproducción de un disco está manchada o raspada, el reproductor podrá decidir que el disco es incompatible y expulsar la bandeja portadiscos, o podría no reproducir el disco correctamente. Limpie cualquier mancha de la superficie de reproducción con un paño suave.

Limpeza de la lente lectora

- No utilice nunca discos de limpieza de venta en el comercio. La utilización de esos discos podría dañar la lente.
- Solicite la limpieza de la lente en el centro de atención al cliente aprobado por Yamaha más cercano.

■ Panel delantero

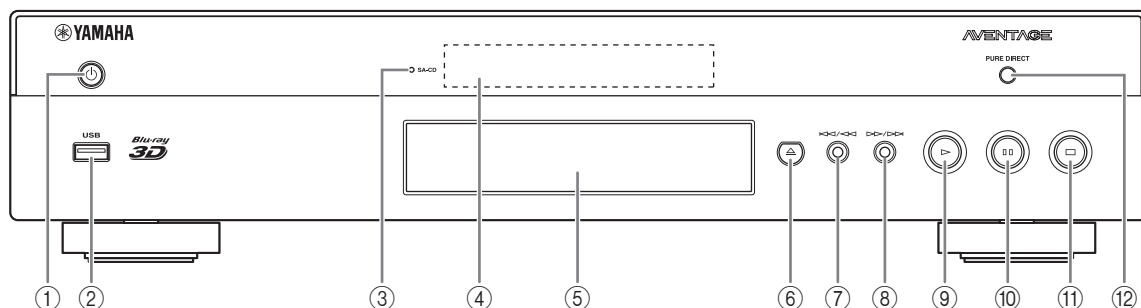

- ① (Encendido/En espera)
- ② Puerto USB (pág. 16)
- ③ **Indicador SA-CD:** Se enciende cuando se carga un SA-CD y se selecciona la capa SA-CD (pág. 4).
- ④ **Visor del panel delantero**
- ⑤ **Bandeja portadiscos (pág. 4)**
- ⑥ (Expulsar): Abre/cierra la bandeja portadiscos.
- ⑦ (Búsqueda hacia atrás/Salto hacia atrás): Pulse para saltar hacia atrás y mantenga pulsado para buscar hacia atrás.
- ⑧ (Búsqueda hacia adelante/Salto hacia adelante): Pulse para saltar hacia adelante y mantenga pulsado para buscar hacia adelante.
- ⑨ (Reproducción)
- ⑩ (Pausa)
- ⑪ (Detener)
- ⑫ **PURE DIRECT:** Pulse esta opción para cambiar el modo Pure Direct (pág. 7) a modo 1/modo 2/desactivado. Este botón se enciende cuando el modo Pure Direct se sitúa en modo 1/modo 2.

Instalación de las pilas en el mando a distancia

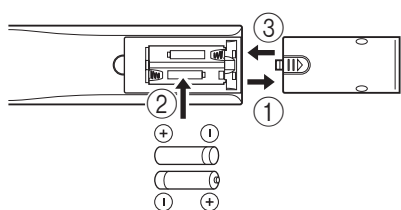

Notas

- No someta al mando a distancia a golpes, agua ni humedad excesiva.
- El mando a distancia podría no funcionar si el sensor del reproductor está expuesto a la luz solar directa o cualquier otra luz fuerte.
- El uso incorrecto de las pilas puede provocar que revienten o tengan fugas. Lea las advertencias para las pilas y utilícelas correctamente.
- No mezcle pilas viejas y nuevas, ni mezcle diferentes marcas.
- Extraiga las pilas si no va a utilizar el mando a distancia durante un periodo de tiempo prolongado.
- Deshágase de las pilas según la normativa de su región.

Alcance aproximado de funcionamiento del mando a distancia

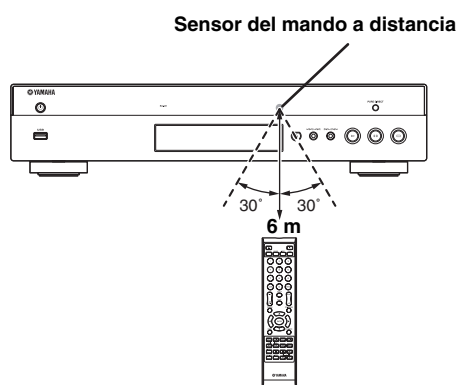

Mando a distancia

Nota

- En la esquina superior izquierda de la pantalla aparecerá  cuando la tecla pulsada no esté disponible.

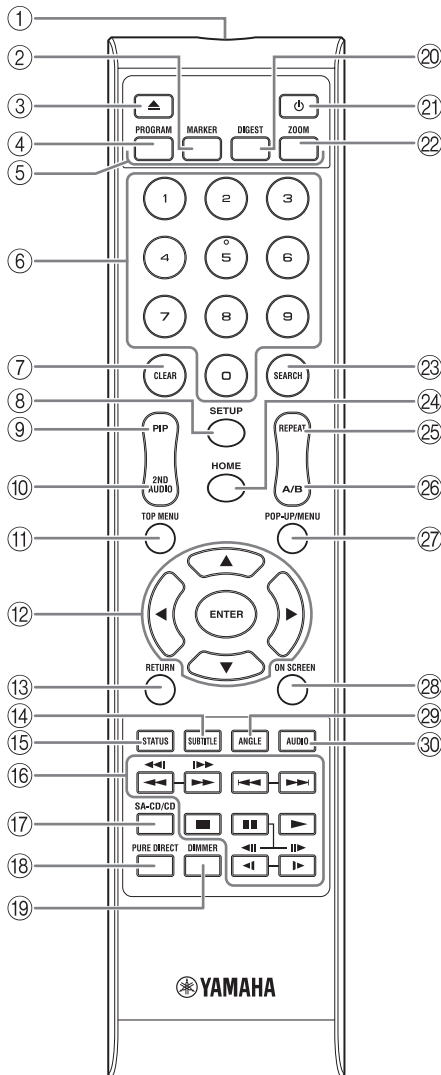

- 1 **Transmisor de señales infrarrojas:** Emite la señal infrarroja. Oriente esta ventana al sensor del mando a distancia (pág. 5).
- 2 **MARKER DVD VIDEO:** Establece un Marcador (pág. 25) en un punto especificado de una película. Tras definir un Marcador, para seleccionar el punto de ajuste al que desea saltar, pulse **DIGEST**. Puede definir hasta 12 marcadores.
- 3 **▲:** Abre/cierra la bandeja portadiscos.
- 4 **PROGRAM DVD CD:** Establece el orden de reproducción (pág. 25). Puede configurar hasta 15 pistas (para discos de audio) o títulos/capítulos (Vídeo DVD).
- 5 **Teclas de colores BD:** Utilice estas teclas según las instrucciones en pantalla.
- 6 **Teclas numéricas:** Permiten introducir números, o durante la reproducción, saltar a la pista/capítulo correspondiente al número introducido. Es posible que estos botones no estén disponibles en función del tipo de disco y la situación de reproducción.
- 7 **CLEAR:** Borra el número introducido o elemento establecido.
- 8 **SETUP:** Muestra la pantalla de menú SETUP (pág. 27).
- 9 **PIP BD:** Permite encender/apagar la función Imagen en imagen (pág. 26). Marca PIP () se muestra en pantalla cuando esta función está disponible. También puede seleccionar este elemento desde el menú en pantalla (pág. 23).

Nota

- Marca PIP se muestra sólo cuando la Marca PIP está encendida (pág. 31).

- 10 **2ND AUDIO BD:** Selecciona el audio secundario de la función Imagen en imagen (pág. 26) o los comentarios de audio. Cuando esta función está disponible se muestra en pantalla Marca Audio Secundario () (pág. 34). También puede seleccionar este elemento desde el menú en pantalla (pág. 23).

Nota

- Marca Audio Secundario se muestra sólo cuando la Marca Audio Secundario está encendida (pág. 31).

- ⑪ **TOP MENU** **BD** **DVD**: Muestra la pantalla de menú principal (pág. 42) si el disco contiene un menú. Seleccione el elemento deseado mediante ▲/▼/◀/▶ y **ENTER**.

Nota

– Las operaciones concretas pueden diferir dependiendo del disco. Siga las instrucciones de cada pantalla de menú.

- ⑫ **Teclas de cursor** (▲/▼/◀/▶): Permiten mover la selección en la pantalla de menú.
ENTER: Elige el menú/elemento seleccionado.
- ⑬ **RETURN**: Permite volver al menú o pantalla anterior, etc.
- ⑭ **SUBTITLE** **BD** **DVD** **VIDEO**: Permite cambiar el idioma de los subtítulos (pág. 42) si está disponible. También puede seleccionar este elemento desde el menú en pantalla (pág. 23).
- ⑮ **STATUS**: Muestra la información de reproducción (pág. 24).

⑯ **Teclas de control**

BD **DVD** **CD** **VIDEO** **MUSIC** **PHOTO**
◀◀/▶▶

BD **DVD** **CD** **VIDEO** **MUSIC**:

Permite buscar hacia atrás/hacia adelante. La velocidad de búsqueda cambiará cada vez que pulse la techa (buscar hacia atrás/adelante: 5 pasos cada una). Pulse ▶ para reanudar la reproducción normal.

PHOTO: Permite cambiar la velocidad de un pase de diapositivas (más lento/más rápido: 3 pasos).

◀◀/▶▶ **BD** **DVD** **CD** **VIDEO** **MUSIC**:

Manténgalo pulsado para realizar una búsqueda o una repetición instantánea. La búsqueda instantánea salta 30 segundos en el contenido. La repetición instantánea reproduce el contenido desde 10 segundos antes.

◀◀/▶▶: Permite saltar hacia atrás/hacia adelante.

■: Detiene la reproducción. Para detener la reproducción completamente, pulse este botón dos veces.

■: Pausa la reproducción.

▶: Reproduce el contenido.

◀ (◀◀)/▶ (▶▶)

BD **DVD**: Realiza una ejecución lenta hacia atrás/hacia adelante. La velocidad de reproducción lenta cambiará cada vez que pulse la tecla (reproducción lenta hacia atrás/adelante: 4 pasos cada una).

Estos botones también permiten la reproducción de avance/retroceso de fotograma durante la pausa.

Pulse ▶ para reanudar la reproducción normal.

Muchos discos de DVD-Audio permiten reproducir pases de diapositivas y girar páginas. Pulse ◀/▶ para pasar a una página anterior o siguiente. Esta función sirve solamente para los DVD-Audio.

Notas

- Algunos discos BD/DVD no son compatibles con la reproducción de avance/retroceso de fotograma.
- En función del disco, el reproductor reanuda la reproducción desde el punto en el que se paró anteriormente el reproductor. Para reproducir desde el principio, pulse ■ dos veces y después ▶.

- ⑰ **SA-CD/CD**: Cambia la capa de reproducción de un SA-CD híbrido entre SA-CD y CD (pág. 4).

Consejo

- El indicador SA-CD/CD (pág. 5), situado en el panel delantero, se enciende cuando se carga un SA-CD y se selecciona la capa SA-CD (pág. 34).

Notas

- Las señales de audio solamente se emiten desde las tomas AUDIO OUT (pág. 11) si la capa SA-CD está seleccionada.
- No es posible reproducir en este reproductor señales de audio grabadas en formato DSD multicanal.

- ⑱ **PURE DIRECT**: Permite cambiar el modo Pure Direct. El modo Pure Direct mostrado a continuación cambiará cada vez que se pulse el botón. El modo Pure Direct mejora la calidad del sonido. En el panel delantero, se enciende PURE DIRECT cuando el modo Pure Direct está en modo 1/modo 2.

Modo 1: el panel delantero se apaga y no se emiten señales de vídeo. Este modo es ideal para escuchar audio.

Modo 2: el visor del panel delantero se apaga y no se emiten las señales de vídeo que no sean del terminal HDMI. Este modo es adecuado para ver películas con sonido de alta calidad.

desactivado: Reproducción normal.

- ⑲ **DIMMER**: Cambia el brillo del visor del panel delantero en 5 pasos.

- ⑳ **DIGEST** **PHOTO**: Muestra 12 fotografías en miniatura. Cuando se muestran las miniaturas, puede continuar a la página siguiente o anterior con ◀◀/▶▶.

DVD **VIDEO**: Muestra la barra de selección Marcador (pág. 25).

- ㉑ **⏻**: Enciende el reproductor o lo pone en modo de espera.

- ㉒ **ZOOM** **DVD** **VIDEO** **PHOTO**: Ampliar/reducir zoom. El tamaño de la pantalla cambiará cada vez que pulse la tecla (ampliar/reducir zoom: 3 pasos cada uno).

Continúa en la página siguiente. ➔

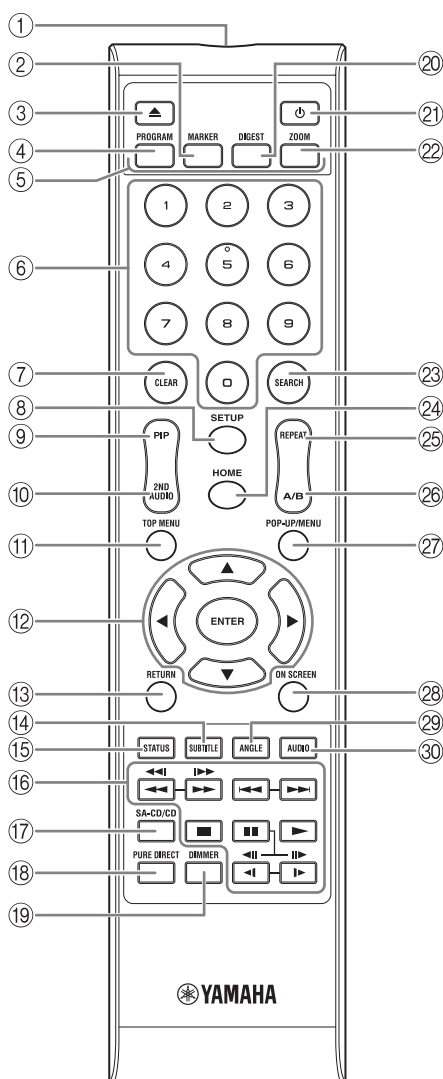

- 23 **SEARCH** **BD** **DVD** **CD** **VIDEO** **MUSIC** : Permite saltar a un punto especificado durante la reproducción. Para conocer los detalles sobre esta función, consulte “Uso de la búsqueda” (pág. 25). También puede seleccionar este elemento desde el menú de estado (pág. 24).
- 24 **HOME**: Muestra la pantalla de menú HOME (pág. 19).
- 25 **REPEAT** **BD** **DVD** **CD** **VIDEO** **MUSIC** **PHOTO** : Permite cambiar el modo de repetición. El modo de repetición mostrado a continuación cambiará cada vez que se pulse el botón.
 - : Permite repetir el título que se está reproduciendo.
 - : Permite repetir el capítulo que se está reproduciendo.
 - : Permite repetir la carpeta que se está reproduciendo.
 - : Permite repetir todas las pistas o los archivos del disco.
 - : Permite repetir la pista o el archivo que se está reproduciendo.
- 26 **A/B** **BD** **DVD** **CD** **VIDEO** **MUSIC** : Permite reproducir una parte específica que desee repetir.
 - 1 Pulse **A/B** en la escena donde desee establecer el punto inicial. En la pantalla se muestra “A-”.
 - 2 Vuelva a pulsar **A/B** en la escena donde desee establecer el punto final. En la pantalla se muestra “A-B”. Se inicia la reproducción de repetición.
 - 3 Para cancelar la reproducción de repetición, pulse **A/B**. “A-B” desaparece y finaliza la reproducción de repetición.

Nota

- Es posible que esta función no se pueda realizar dependiendo de las especificaciones del disco.
- 27 **POP-UP/MENU** **BD** **DVD** : Muestra el menú emergente. Los contenidos del menú que se visualiza varían en función del disco. Consulte los detalles sobre cómo ver y operar el menú emergente en el manual del disco. La pantalla del menú principal se puede mostrar pulsando **POP-UP/MENU**, dependiendo del DVD.
- 28 **ON SCREEN**: Muestra el menú en pantalla (pág. 23).
- 29 **ANGLE** **BD** **DVD** : Permite cambiar el ángulo de la cámara si el vídeo se ha grabado con varios ángulos. Cuando esta función está disponible se muestra en pantalla Marca de Ángulo (). También puede seleccionar este elemento desde el menú en pantalla (pág. 23).

Nota

- Marca de Angulo se muestra sólo cuando la Marca de Angulo está encendida (pág. 31).
- ③ **AUDIO** **BD** **DVD**: Permite cambiar el idioma o formato de audio. También puede seleccionar este elemento desde el menú en pantalla (pág. 23).

Función ID

Puede modificar el ID del mando a distancia para evitar una utilización no deseada de otro reproductor Yamaha, como un reproductor de DVD. Si modifica el ID del mando a distancia, seleccione el mismo ID para la unidad principal. La configuración predeterminada es ID1.

1 Configuración del mando a distancia

Para modificar el ID de ID1 a ID2, mantenga pulsado el botón de color rojo y el botón **2** de los botones numéricos simultáneamente durante 7 segundos. Para modificar el ID de ID2 a ID1, mantenga pulsado el botón de color rojo y el botón **1** de los botones numéricos simultáneamente durante 7 segundos.

2 Configuración de la unidad principal

Mantenga pulsado **◀◀/◀◀** y **▶▶/▶▶** en el panel delantero simultáneamente durante 2 segundos para mostrar el ID actual si:

- No hay ningún disco en el reproductor.
- La bandeja portadiscos está cerrada.
- Se detiene la reproducción.
- “NO DISC” aparece en el visor del panel delantero.

Mantenga pulsadas las teclas durante 2 segundos más para cambiar el ID de ID1 a ID2.

Nota

- Si el mando a distancia está sin pilas durante unos minutos o si se dejan pilas agotadas en el mando a distancia, el ID del mando a distancia se ajusta automáticamente en ID1. Si desea utilizar el mando a distancia con el ajuste ID2, coloque pilas nuevas y vuelva a configurar el ID del mando a distancia.

INTRODUCCIÓN A LAS CONEXIONES

Encuentre el método de conexión que corresponde a su equipo de vídeo/audio. Le recomendamos que utilice el terminal HDMI que ofrece audio y vídeo digital de alta calidad en una única conexión. Si utiliza los demás terminales/conectores, conecte el vídeo en primer lugar. A continuación, conecte el audio.

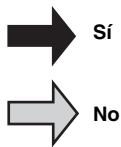
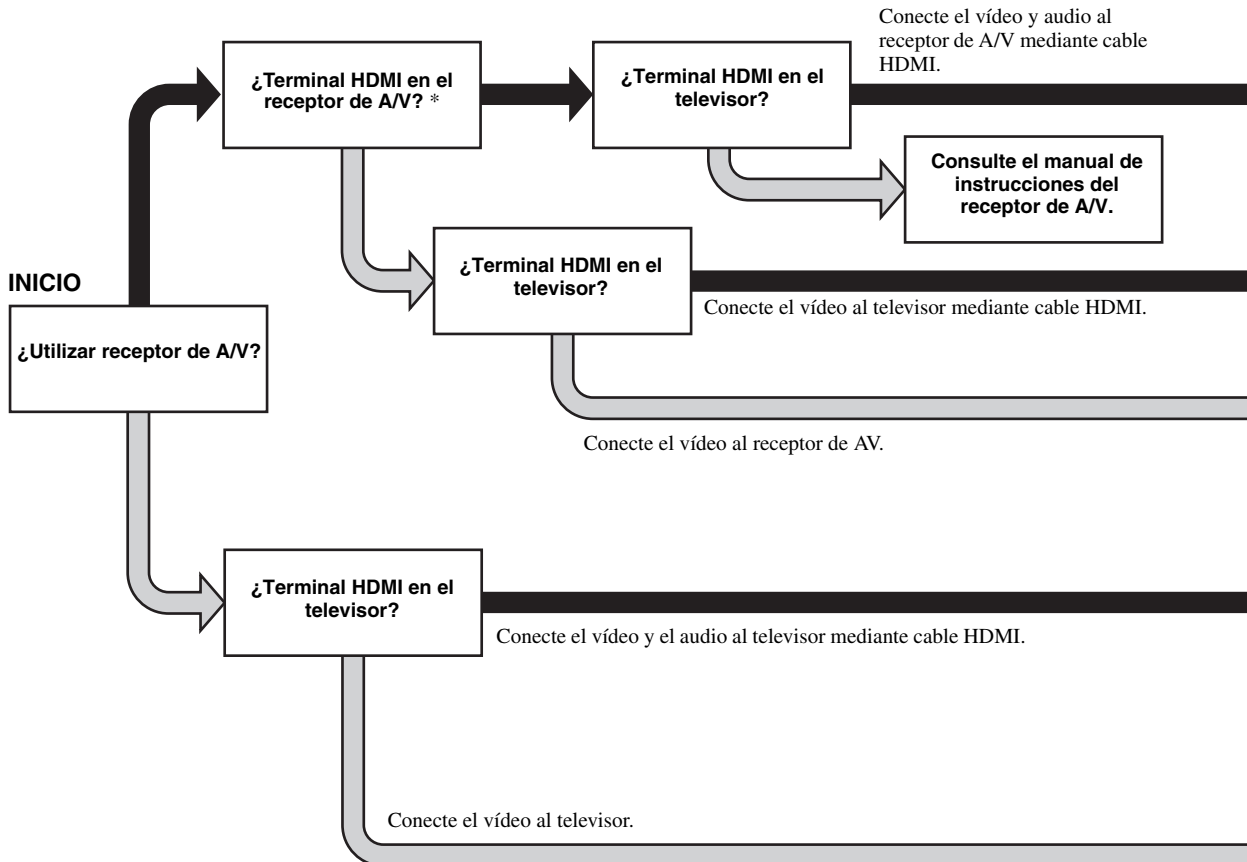

* Cuando conecte a un receptor de A/V que no pueda dar salida a la entrada de sonido a través de su terminal HDMI, consulte el manual de instrucciones del receptor de A/V.

■ Panel trasero

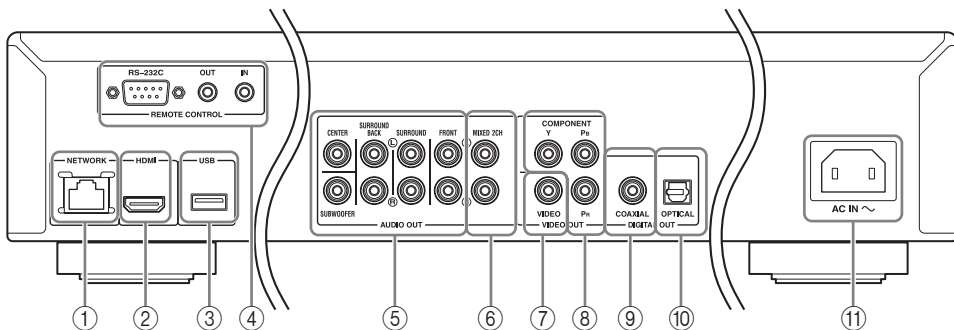

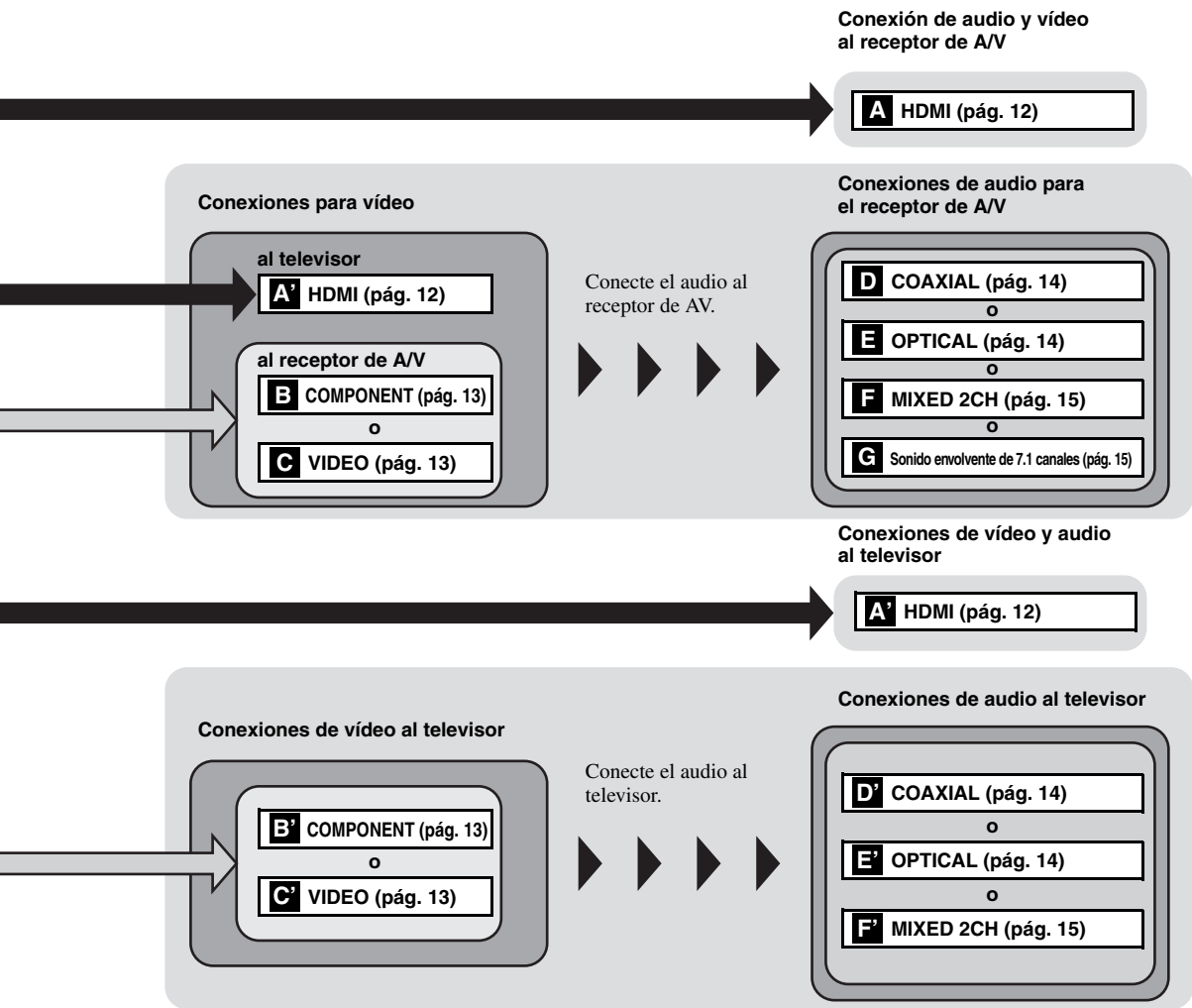

- ① NETWORK (pág. 16)
- ② HDMI (pág. 12)
- ③ Puerto USB (pág. 16)
- ④ REMOTE CONTROL (IN/OUT/RS-232C) (pág. 17)
- ⑤ Sonido envolvente de 7.1 canales (AUDIO OUT) (pág. 15)

- ⑥ MIXED 2CH (AUDIO OUT) (pág. 15)
- ⑦ VIDEO (pág. 13)
- ⑧ COMPONENT (pág. 13)
- ⑨ COAXIAL (pág. 14)
- ⑩ OPTICAL (pág. 14)
- ⑪ AC IN (pág. 17)

HDMI CONEXIONES

■ Conexión con el terminal HDMI

- Puede disfrutar de imagen y sonido digital de alta calidad a través del terminal HDMI.
- Conecte con firmeza un cable HDMI (de venta en el comercio) a los terminales HDMI.
- Consulte la página 35 para obtener información sobre los formatos de salida de audio/vídeo.
- Utilice cables HIGH SPEED HDMI que dispongan del logotipo HDMI (tal como se muestra en la cubierta trasera).

¡Precaución!

No conecte el cable de alimentación del reproductor hasta haber finalizado todas las conexiones.

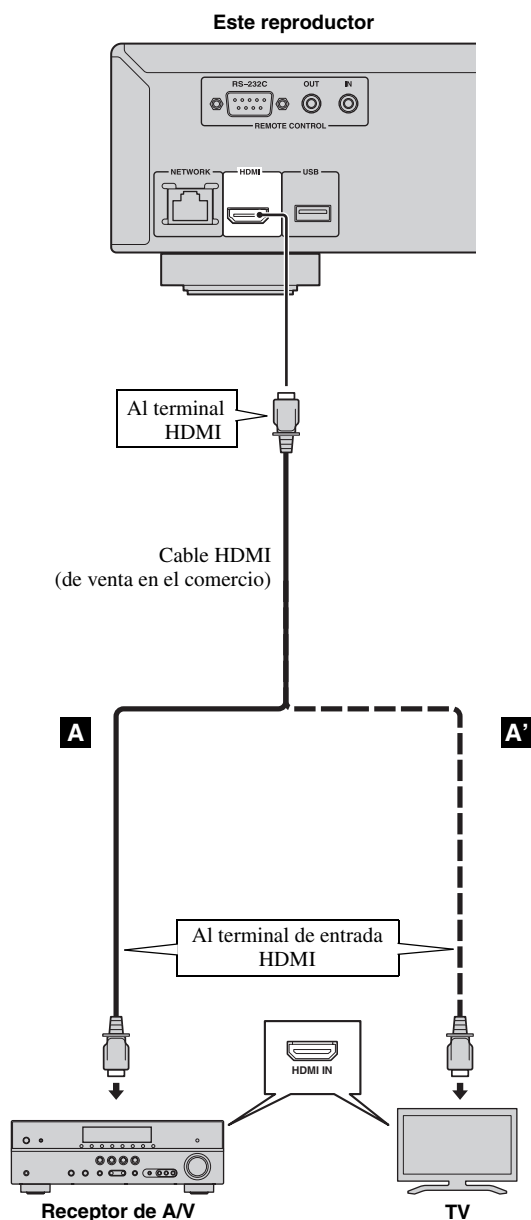

Consejos

- Cuando utilice la función Control HDMI, consulte “Control HDMI” (pág. 30).
- Para más información sobre el modo de salida del terminal HDMI, consulte “HDMI” (pág. 34).
- Si no se muestra la imagen, consulte “RESOLUCIÓN DE PROBLEMAS” (pág. 39).

■ Conexión para la reproducción de discos 3D de Blu-ray

Para disfrutar de discos 3D de Blu-ray en este reproductor, necesita los equipos y conexiones siguientes:

- Necesita un televisor y un receptor de A/V (en caso necesario) con funcionalidad 3D.
- Todos los componentes deben estar conectados con cables HDMI.
- El disco Blu-ray debe contener imágenes 3D.

CONEXIONES DE VÍDEO

■ Conexión a la toma de vídeo componente

- Puede disfrutar de una reproducción de color precisa y de imágenes de alta calidad a través de las tomas de componente.
- Conecte con firmeza un cable de vídeo componente (vendido en comercios) o un cable de clavijas de vídeo a la toma COMPONENT/toma de VIDEO.
- Consulte la página 36 para obtener información sobre los formatos de salida de vídeo.

¡Precaución!

No conecte el cable de alimentación del reproductor hasta haber finalizado todas las conexiones.

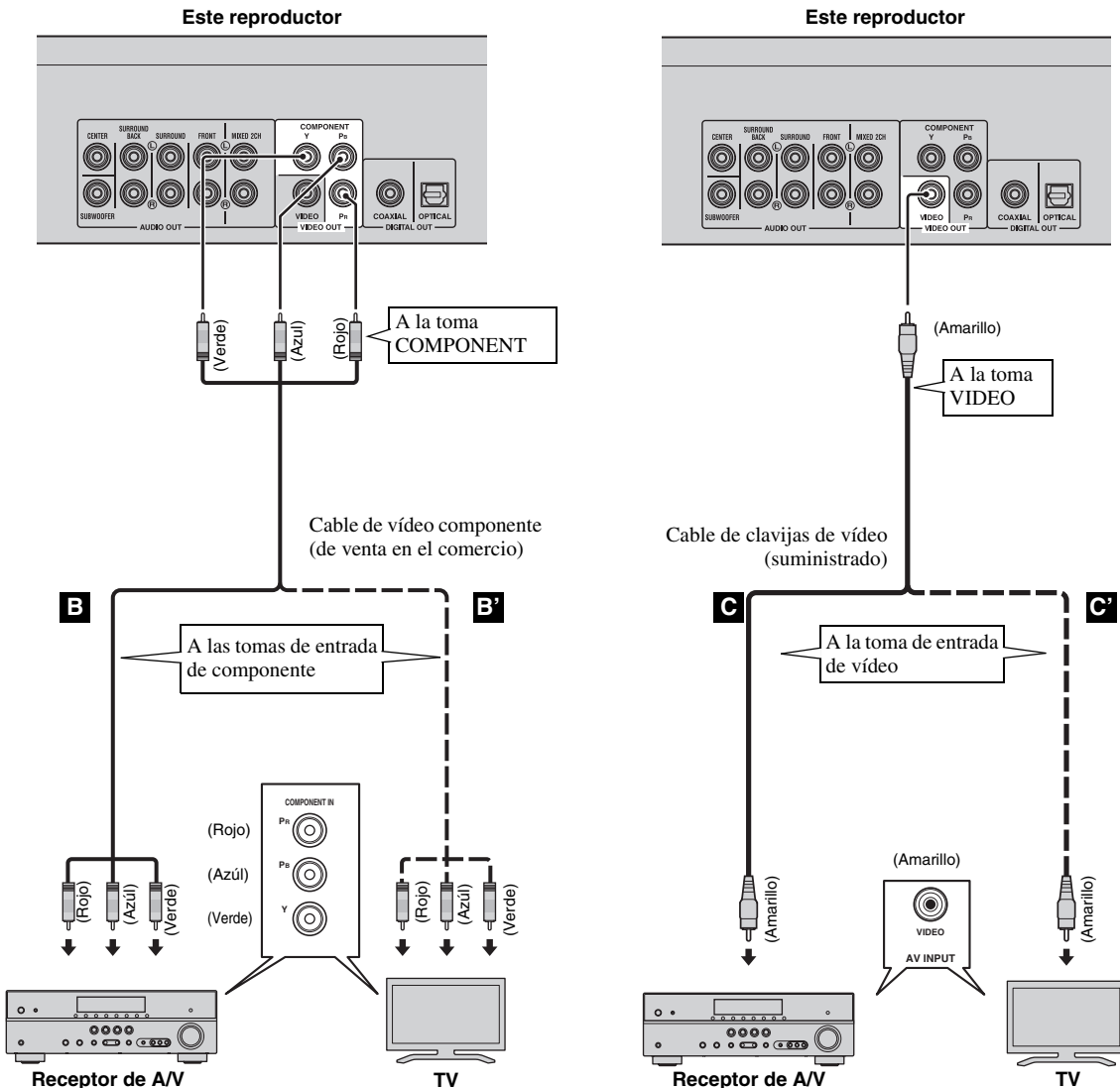

Notas

- Si reproduce la imagen mediante una videograbadora, la imagen puede deteriorarse debido a la función de protección contra la copia.
- Para disfrutar de discos BD-3D en este reproductor, necesita conectar un receptor de A/V, un televisor y este reproductor con cables HDMI. Consulte la página anterior.

CONEXIONES DE AUDIO

■ Conexión con el terminal/toma de audio digital

- Puede conectar el equipo de audio o el televisor en la toma COAXIAL o el terminal OPTICAL.
- Conecte con firmeza un cable de audio digital coaxial (de venta en el comercio) o un cable óptico (de venta en el comercio) a la toma de audio digital coaxial o al terminal de audio digital óptico.
- Consulte la información sobre los formatos de salida de audio en la página 35.

¡Precaución!

No conecte el cable de alimentación del reproductor hasta haber finalizado todas las conexiones.

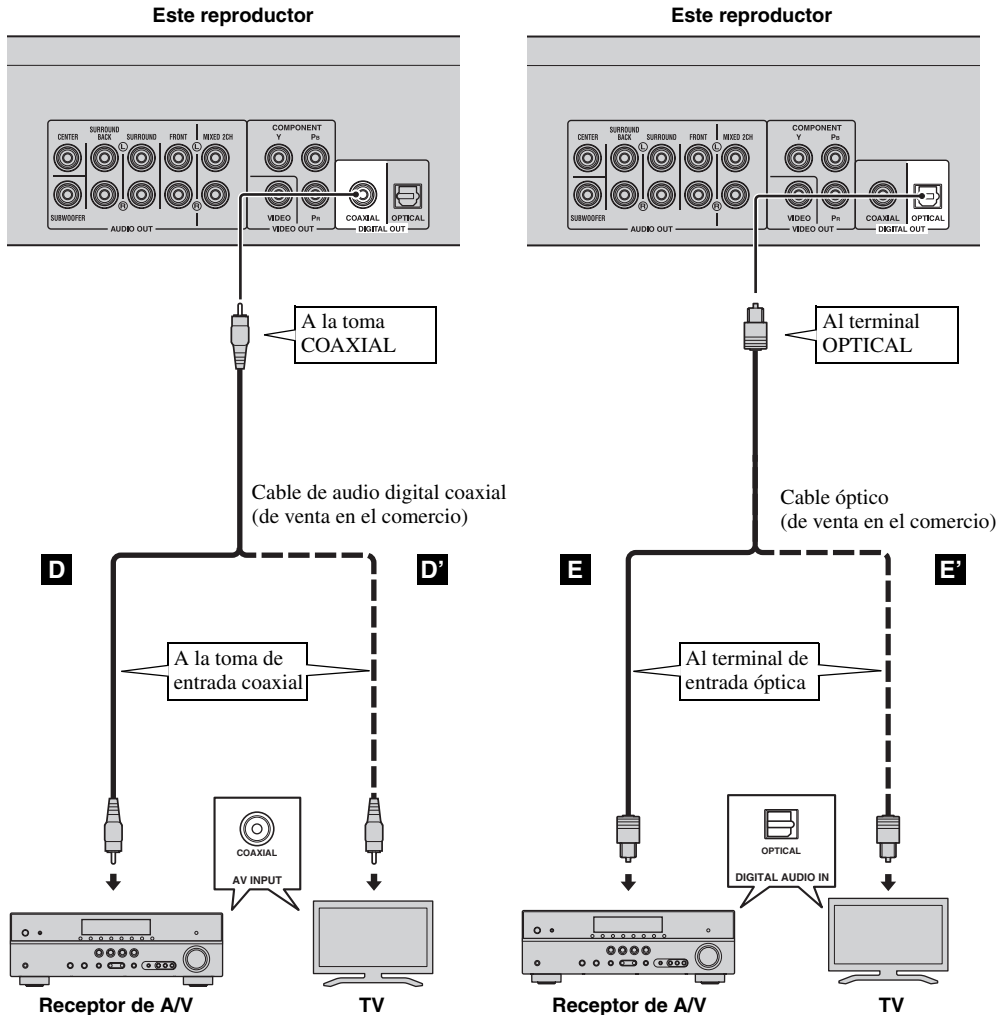

Consejo

- Para más información sobre el modo de salida de la toma COAXIAL o terminal OPTICAL, consulte "Coaxial/Optica" (pág. 34).

■ Conexión con las tomas de audio

- Puede conectar el equipo de audio o el televisor en las tomas MIXED 2CH/sonido envolvente de 7.1 canales.
- Conecte con firmeza cables de clavijas de audio (suministrados o vendidos en comercios) a las tomas MIXED 2CH o las tomas de sonido envolvente de 7.1 canales.
- Consulte la información sobre los formatos de salida de audio en la página 35.
- Si desea reproducir audio SA-CD y DVD-Audio multicanal, conecte las tomas de sonido envolvente de 7.1 canales a las tomas de entrada correspondientes del receptor de A/V mediante cables de clavijas de audio vendidos en comercios.

¡Precaución!

No conecte el cable de alimentación del reproductor hasta haber finalizado todas las conexiones.

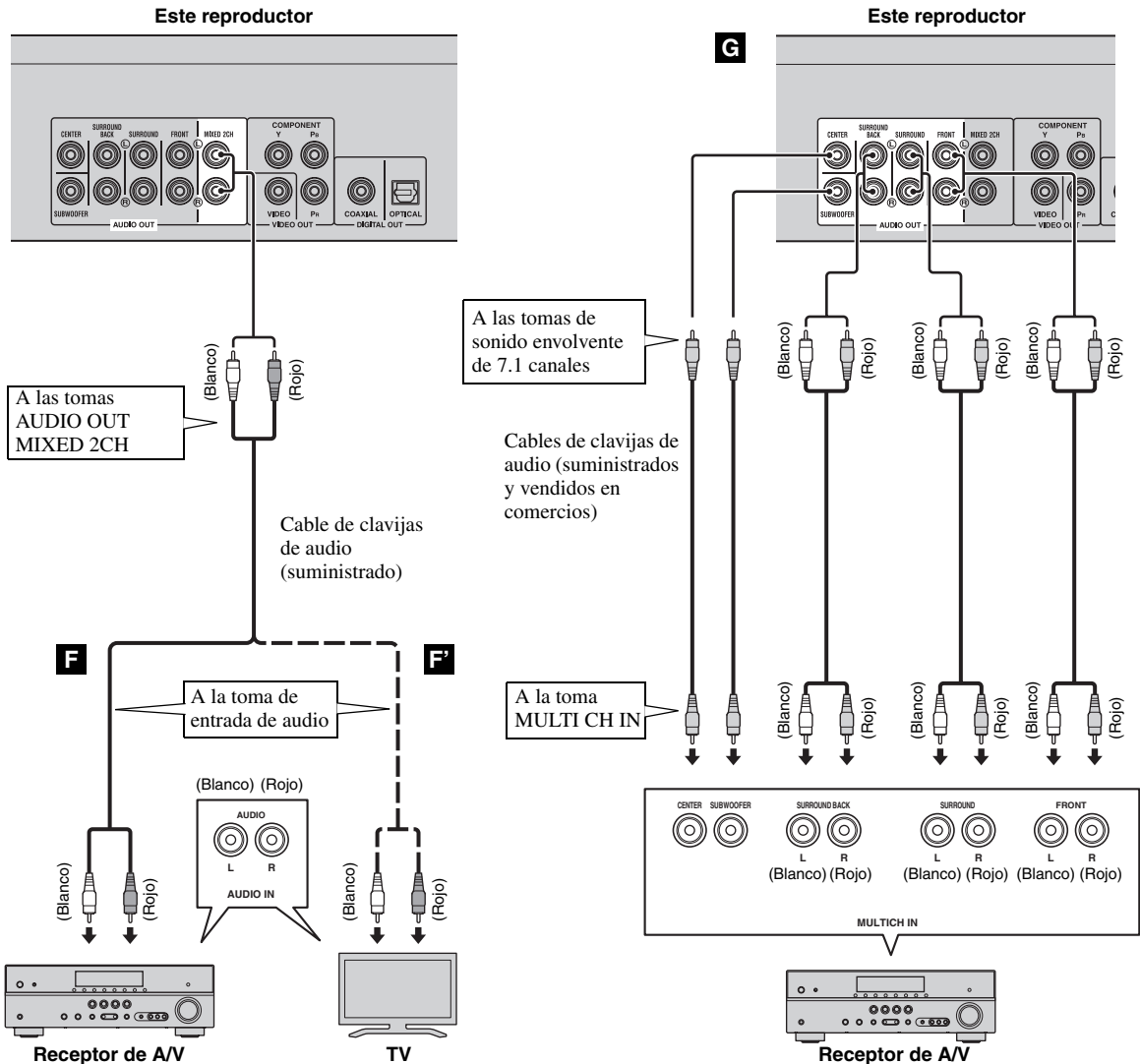

Consejos

- Puede conectar un altavoz de graves directamente a la toma SUBWOOFER. Si conecta el televisor directamente a este reproductor, conecte un altavoz de graves activo, como el Yamaha Active Servo Processing Subwoofer System, a esta toma.
- Para emitir la señal de audio desde las tomas MIXED 2CH/de sonido envolvente de 7.1 canales, consulte "Ajuste de altavoz" (pág. 34).

CONEXIÓN DE RED Y USB

■ Conexión con el terminal NETWORK y el puerto USB

- El contenido del PC se puede reproducir conectando este reproductor a la red.
- Puede disfrutar de una variedad de contenido con funciones interactivas gracias a la conexión a Internet cuando reproduzca discos compatibles BD-Live. Consulte la página 26 para obtener información adicional sobre las funciones de BD-Live.
- Puede conectar un dispositivo de memoria USB (2 GB o superior y formateado con FAT 32/16) para BD Almacenamiento Local al puerto USB del panel posterior (o delantero) del reproductor para guardar los datos BD-Live o para actualizar el software de este reproductor.
- Conecte con firmeza un cable de red (vendido en comercios) y un dispositivo de memoria USB (vendido en comercios) al terminal NETWORK y al puerto USB.
- Utilice sólo un cable de red STP (par trenzado blindado).
- Cuando se emplee Internet, se necesita una conexión a Internet de banda ancha como se muestra más abajo.
- Conecte el otro conector del cable de red al nodo/enrutador de banda ancha.

Antes de utilizar el dispositivo de memoria USB

PRECAUCIÓN:

- No desconecte el dispositivo de memoria USB ni desenchufe el cable de alimentación mientras se estén realizando las operaciones de BD-Live (pág. 26) o se esté llevando a cabo la actualización del software.
- No utilice un cable de extensión USB cuando conecte un dispositivo de memoria USB al puerto USB del reproductor. El uso de un cable de extensión USB podría impedir que el reproductor funcione correctamente.

Nota

- Yamaha no puede garantizar que todas las marcas de dispositivos de memoria USB funcionen con este reproductor.

Notas

- Cuando utilice una conexión a Internet de banda ancha, es necesario un contrato con un proveedor de servicios de Internet. Para más información, póngase en contacto con su proveedor de servicios de Internet más cercano.
- Consulte el manual de manejo de su equipo ya que el equipo conectado y el método de conexión pueden variar dependiendo de su entorno de Internet.
- Emplee un cable de red/enrutador compatible con 10BASE-T/100BASE-TX.

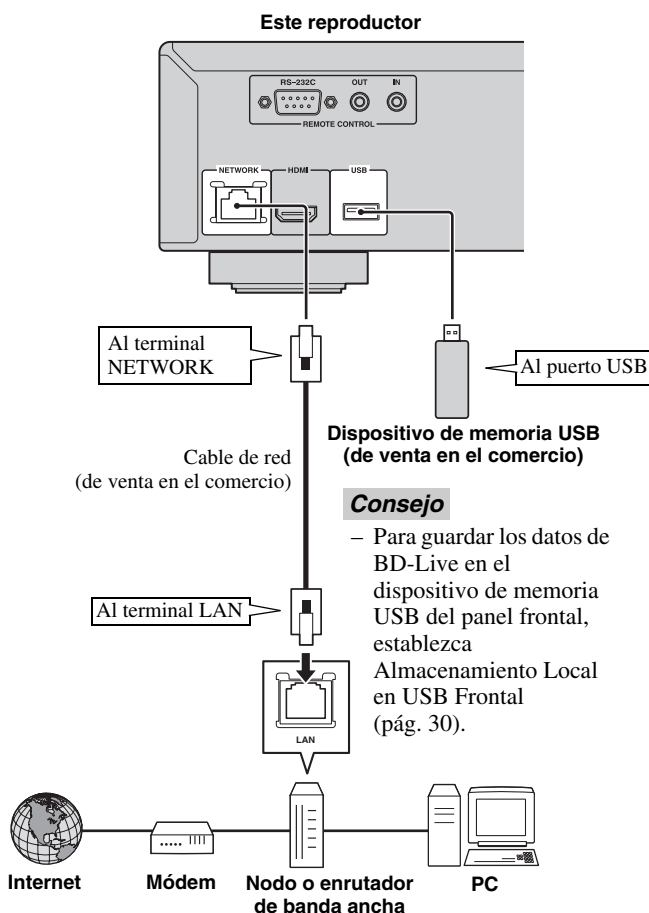

Después de la conexión

- Para establecer el parámetro de Red manualmente, consulte "Red" (pág. 32).
- Para reproducir el contenido del PC en su red, consulte "Uso del contenido de red" (pág. 21).

OTRAS CONEXIONES

■ Conexión a las tomas REMOTE CONTROL

- Puede transmitir y recibir las señales del mando a distancia conectando a las tomas REMOTE CONTROL (OUT/IN).
- Conecte con firmeza cables con mini clavija mono de 3,5 mm (de venta en el comercio) en los terminales REMOTE CONTROL (OUT/IN).
- Si su receptor de AV es un producto Yamaha y tiene la capacidad de transmitir señales de control SCENE, puede controlar el reproductor con la función SCENE.

¡Precaución!

No conecte el cable de alimentación del reproductor hasta haber finalizado todas las conexiones.

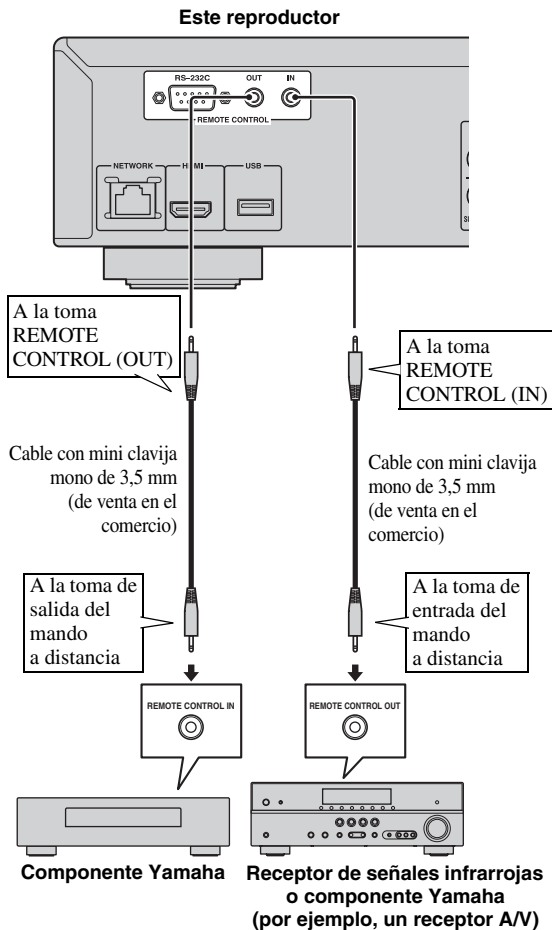

Consejos

- Para más detalles sobre la función SCENE, consulte el manual de instrucciones de su receptor de A/V Yamaha.

- Puede conectar un componente Yamaha (como, por ejemplo, un reproductor de CD) que sea compatible con la función SCENE a la toma REMOTE CONTROL (OUT) de este reproductor.
- El terminal RS-232C es un terminal de ampliación de control para usos comerciales. Solicite más información a su distribuidor.

■ Conexión del cable de alimentación

- Después de realizar todas las conexiones, enchufe el cable de alimentación suministrado a la AC IN de la parte trasera del reproductor. A continuación enchúfelo en una toma de CA.

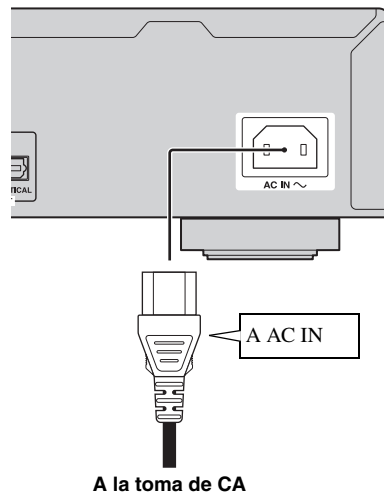

Nota

- PARA PREVENIR EL RIESGO DE DESCARGAS ELÉCTRICAS, NO TOQUE LAS PARTES SIN AISLAMIENTO DE NINGÚN CABLE CUANDO EL CABLE DE ALIMENTACIÓN ESTÉ CONECTADO.

ASISTENTE INICIAL/CONFIGURACIÓN SENCILLA

■ Configuración con el Asistente inicial/Configuración Sencilla

Asistente inicial/Configuración Sencilla le permite establecer con facilidad el idioma, la resolución y la relación de aspecto de pantalla. La pantalla Asistente inicial se muestra cuando enciende el reproductor por primera vez después de la compra o actualización. El mismo ajuste se puede realizar desde el menú **SETUP** → Sistema → Configuración Sencilla.

- 1 Cuando se muestre la pantalla Configuración Sencilla, pulse **ENTER** para iniciar Configuración Sencilla.

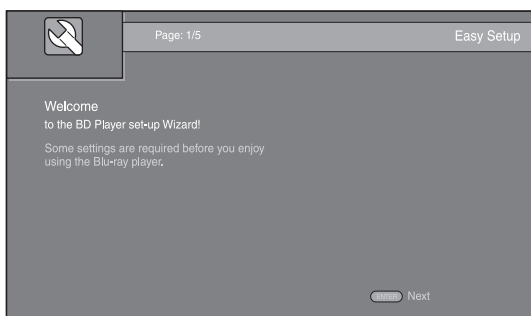

- 2 Pulse **▲/▼** para seleccionar el idioma que desea ver en la pantalla y, después, pulse **ENTER**.

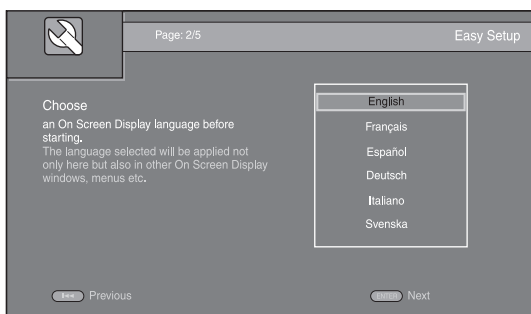

- 3 Pulse **▲/▼** para seleccionar la resolución, a continuación pulse **ENTER**. Para obtener detalles sobre la configuración de elementos, consulte “Resolución” (pág. 33).

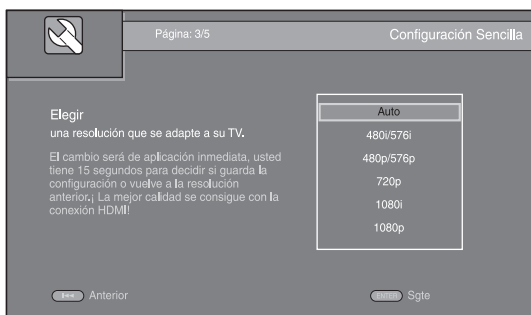

- 4 Pulse **▲/▼** para seleccionar la relación de aspecto de pantalla, a continuación pulse **ENTER**. Para más detalles sobre la configuración de elementos, consulte “Pantalla de TV” (pág. 32).

La Configuración Sencilla se ha completado.

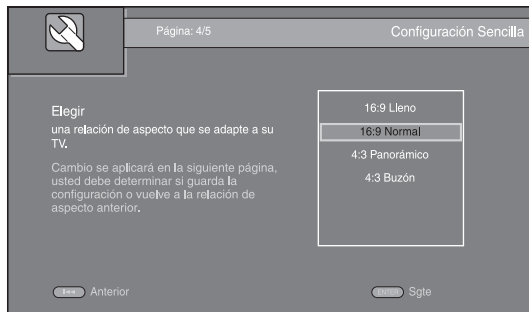

- 5 Pulse **ENTER** para salir de Configuración Sencilla.

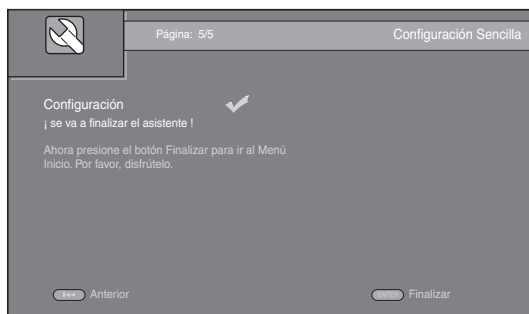

Notas

- Si no se muestra la imagen tras completar Asistente inicial/Configuración Sencilla, consulte “RESOLUCIÓN DE PROBLEMAS” (pág. 39).
- Aparecerá un mensaje de advertencia acerca de la reproducción de vídeo en 3D cuando este reproductor esté encendido. Pulse **ENTER** para descartar el mensaje o **CLEAR** para desactivarlo (pág. 30).

MENÚ HOME/MEDIA

Los menús HOME y MEDIA le permiten examinar y reproducir archivos multimedia en discos de datos, dispositivos de memoria USB y su red.

Nota

- Para conocer los detalles sobre los discos y formatos que se pueden reproducir, consulte la página 3.

■ Reproducción de Foto/Música/Vídeo

Funcionamiento básico

- ▲/▼: Mueve la selección.
- ◀: Vuelve a la carpeta principal.
- ▶: Activa/desactiva el archivo/carpeta simple.
- HOME**: Permite entrar/salir de la pantalla de menú HOME.
- ENTER**: Confirma la carpeta/archivo.

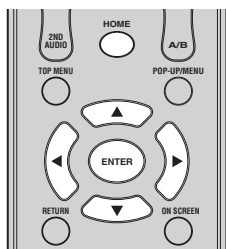

Iconos sobre el menú MEDIA

- : Reproduce el disco que hay en la bandeja o muestra el contenido del disco de datos.
- : Muestra el contenido del dispositivo de memoria USB conectado al puerto USB.
- : Busca un servidor DLNA (pág. 21) en la red.
- : Muestra el contenido del servidor DLNA conectado.

Operaciones comunes para la reproducción de archivos en una carpeta seleccionada

Ejemplo: Selección de un archivo de película en un dispositivo de memoria USB

Nota

- Detenga la reproducción del vídeo antes de desplazarse a la pantalla de menú MEDIA.

- 1 Pulse **HOME** para pasar a la pantalla del menú HOME. Pulse ◀/▶ para seleccionar MEDIA y pulse **ENTER**.



- 2 Aparece la pantalla MEDIA.

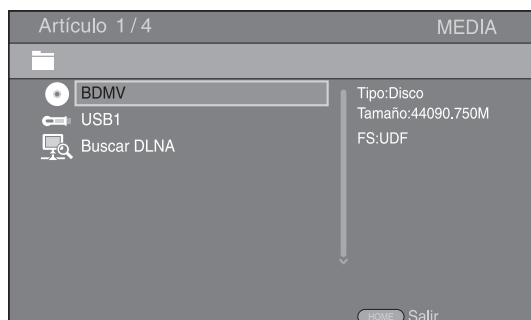

- 3 Seleccione el elemento que contiene el archivo que desea reproducir, a continuación pulse **ENTER**.

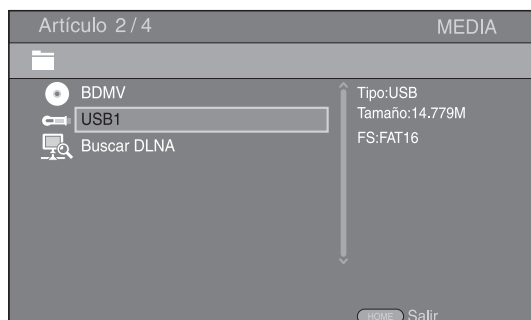

3

REPRODUCCIÓN

Español

- 4 Seleccione la carpeta Foto, Música, Vídeo o AVCHD que desea reproducir, a continuación pulse **ENTER**. Para volver a la carpeta principal, pulse ◀ o seleccione **HOME**.



Nota

- Tenga en cuenta que en el siguiente paso sólo se mostrarán los archivos del tipo que seleccione en este paso. Por ejemplo, si selecciona la carpeta Foto en este paso, sólo se mostrarán archivos de fotos después de este paso. Cuando desee reproducir un tipo de archivo distinto a foto, vuelva a esta jerarquía y seleccione de nuevo el tipo de archivo.

- 5 Seleccione las carpetas que contienen el archivo que desea reproducir.

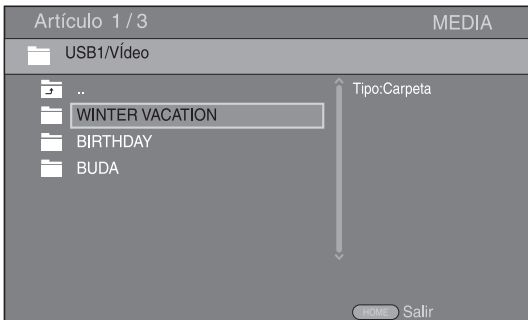

- 6 Seleccione el archivo que desea reproducir, a continuación pulse **ENTER**.

Cuando se selecciona un archivo de vídeo se inicia la reproducción.

Cuando se selecciona un archivo de música, se muestra la pantalla de estado y se inicia la reproducción.

Cuando se selecciona un archivo de fotografía se inicia el pase de diapositivas.

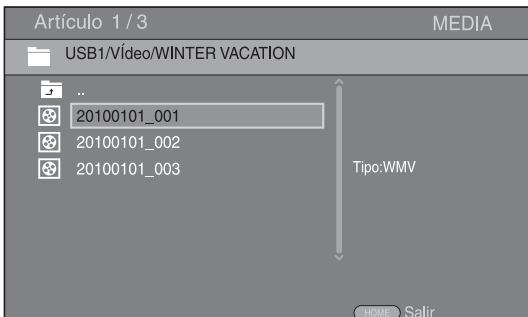

Consejo

- Para disfrutar del pase de diapositivas con música, pulse **HOME** para volver a la pantalla de menú HOME mientras se reproduce la música y seleccione archivo de fotos.

Nota

- Es posible que el archivo mostrado no se reproduzca dependiendo del contenido.

Operaciones para visualización de fotos

Mientras se ven fotos los botones del mando a distancia funcionan como se indica a continuación.

■: Detiene el pase de diapositivas y vuelve al explorador de archivos.

■ ■: Establece una pausa en un pase de diapositivas.

▶: Reproduce un pase de diapositivas.

▶▶: Pasa a la fotografía siguiente.

◀◀: Pasa a la fotografía anterior.

▶▶▶: Acelera un pase de diapositivas en 3 pasos.

◀◀◀: Ralentiza un pase de diapositivas en 3 pasos.

▲: Invierte una foto.

▼: Muestra la foto reflejada.

◀: Gira una foto en sentido contrario a las agujas del reloj.

▶: Gira una foto en el sentido de las agujas del reloj.

ZOOM: Amplía/reduce una foto (ampliar/reducir zoom: 3 pasos cada uno).

▲/▼/◀/▶: Permite desplazarse en modo de zoom cuando la foto es mayor que la pantalla.

DIGEST: Cambia a modo de miniaturas (pág. 7). Cuando se muestran las miniaturas, puede continuar a la página siguiente o anterior con ◀◀/▶▶.

■ Uso del contenido de red

Este reproductor es un reproductor multimedia digital certificado para DLNA. Puede administrar contenido de fotos, música y vídeo almacenado en servidores DLNA en su red doméstica.

Acerca de DLNA

DLNA (Digital Living Network Alliance) permite compartir de forma sencilla medios digitales a través de una red doméstica y puede disfrutar del contenido digital almacenado en su software, PC instalado, servidor DLNA u otro dispositivo compatible con DLNA con su TV a través de este reproductor. Para conectar este reproductor a sus servidores DLNA se requieren algunos ajustes del dispositivo o del servidor DLNA. Para más detalles, consulte el software del servidor DLNA o el dispositivo DLNA.

Reproducción de contenido compartido

- 1 Para reproducir archivos en el PC, instale un software de servidor DLNA como, por ejemplo Windows Media Player 12 y comparta los archivos que desee reproducir.
- 2 Encienda el PC con el software de servidor DLNA instalado o el dispositivo DLNA conectado a su red doméstica.
- 3 Pulse **HOME** para mostrar la pantalla de menú HOME. Seleccione **MEDIA** para pasar al menú MEDIA. Los servidores DLNA conectados a la red aparecen en pantalla.

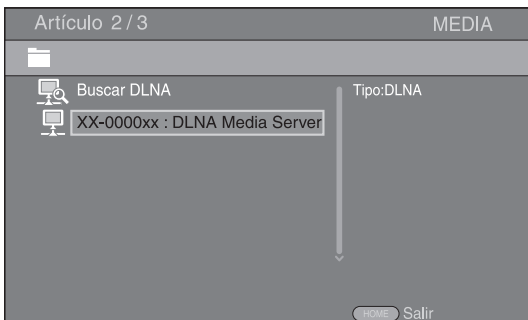

Notas

- Si su servidor DLNA no aparece en la lista, seleccione **Buscar DLNA** para buscarlo.
- Dependiendo del servidor DLNA, es posible que sea necesario autorizar al reproductor desde el servidor.
- Para reproducir el archivo en el servidor DLNA, el reproductor y el servidor deben estar conectados al mismo punto de acceso.
- Es posible que los requisitos de archivo no siempre sean compatibles. Podría haber algunas restricciones dependiendo de las características de los archivos y de la capacidad del servidor DLNA.

- 4 Seleccione el archivo que desee reproducir.

Notas

- La calidad de funcionamiento y reproducción podría verse afectada por las condiciones de la red doméstica.
- Es posible que los archivos de medios extraíbles tales como dispositivos de memoria USB o unidades de DVD del servidor de medios no se compartan correctamente.

USO DE SERVICIOS DE RED

Puede ver instantáneamente los vídeos que proporcionan los servicios de red siguientes.

- YouTube

Notas

- El acceso a contenido suministrado por terceros requiere una conexión de Internet de alta velocidad y también un registro de cuenta y una suscripción de pago.
- Los servicios de contenido de terceros pueden modificarse, suspenderse, interrumpirse o dejar de proporcionarse en cualquier momento sin previo aviso, y Yamaha no asume ninguna responsabilidad en relación con dichos sucesos.
- Es posible que parte del contenido sólo esté disponible para países específicos y que se presente en idiomas específicos.
- Yamaha no representa ni garantiza que los servicios de contenido se seguirán proporcionando o estarán disponibles durante un periodo de tiempo concreto, y se rechaza cualquier garantía de este tipo, ya sea expresa o implícita.

REPRODUCCIÓN DE VÍDEOS DESDE YouTube™

Puede ver películas desde YouTube a través de Internet mediante este reproductor.

Los servicios pueden modificarse sin previo aviso.

- 1 Pulse **HOME** para mostrar la pantalla de menú HOME.

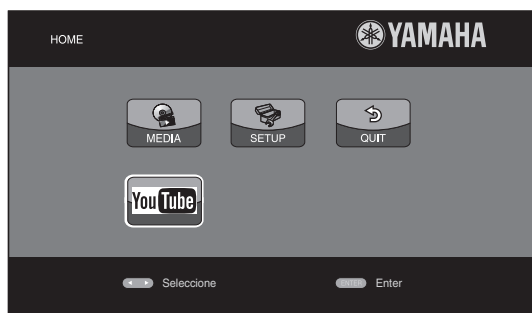

Consejo

- La pantalla de menú HOME puede variar en función del modelo.

- 2 Pulse **▲/▼/◀/▶** para seleccionar YouTube, a continuación pulse **ENTER**.

Consejo

- Para volver a la pantalla de menú HOME, pulse **RETURN**.

FUNCIONAMIENTO DE REPRODUCCIÓN AVANZADO

3

REPRODUCCIÓN

En este capítulo se explica la reproducción de discos BD y DVD vendidos en comercios, SA-CD, CD y discos DVD-RW/R grabados.

Nota

- Para conocer el funcionamiento básico de reproducción, consulte la página 6.

Menú en pantalla

Para mostrar el menú en pantalla, pulse **ON SCREEN**. A continuación, pulse **▲/▼/◀/▶** para seleccionar un elemento, después pulse **ENTER** para utilizar la función deseada.

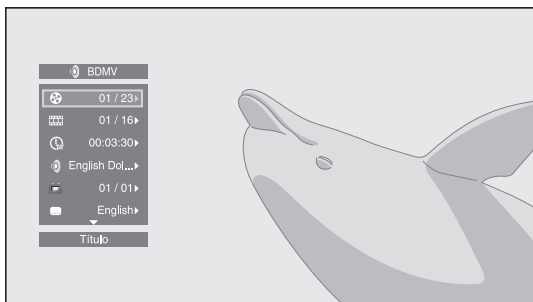

El menú en pantalla consta de los siguientes elementos.

Título **BD** **DVD** **VIDEO**: Muestra el número del título que se está reproduciendo. Puede saltar al título deseado seleccionándolo desde este elemento.

Capítulo **BD** **DVD** **VIDEO**: Muestra el número del capítulo que se está reproduciendo. Puede saltar al capítulo deseado seleccionándolo desde este elemento.

Pista/Archivo **CD** **VIDEO** **MUSIC** **PHOTO**: Muestra el número de la pista o archivo que se está reproduciendo. Puede saltar a la pista o al archivo deseado seleccionándolo desde este elemento.

Hora **BD** **DVD** **CD** **VIDEO** **MUSIC**: Muestra el tiempo de reproducción. Seleccione el tipo de visualización entre los siguientes:

- Tiempo de reproducción transcurrido del título, capítulo, disco, pista o archivo
- Tiempo de reproducción restante del título, capítulo, disco, pista o archivo

Modo/Modo de reproducción

DVD **CD** **VIDEO** **MUSIC** **PHOTO**: Muestra el modo de reproducción actual. Puede seleccionar uno de los modos de reproducción siguientes:

CD

- Normal: Reproducción normal.
- Shuffle: Reproducción aleatoria sin repetición.
- Aleatorio: Reproducción aleatoria con repetición.

DVD

- Normal
- Shuffle CH (capítulo)
- Shuffle TT (título)
- Shuffle All
- Aleatorio CH (capítulo)
- Aleatorio TT (título)
- Aleatorio All

VIDEO MUSIC PHOTO

- Normal
- Shuffle F (carpeta)
- Shuffle All
- Aleatorio F (carpeta)
- Aleatorio All

Audio **BD** **DVD** **VIDEO**: Muestra el idioma/señal de audio del disco BD/DVD seleccionado actualmente. Puede seleccionar el tipo de audio deseado.

Ángulo **BD** **DVD**: Muestra el número del ángulo seleccionado actualmente. Si el vídeo se ha grabado con varios ángulos, puede cambiar el ángulo.

Subtítulo **BD** **DVD** **VIDEO**: Muestra el idioma de los subtítulos seleccionados actualmente si hay subtítulos.

Estilo subtítulos **BD**: Muestra el estilo de los subtítulos seleccionados actualmente. Esta función sólo está disponible para subtítulos externos de archivo de vídeo. Puede seleccionar el estilo de texto deseado de los subtítulos.

Bitrate **BD** **DVD** **CD** **VIDEO** **MUSIC**: Muestra el bitrate de la señal de audio/vídeo.

Video secundario **BD**: Activa o desactiva PIP (pág. 6).

Audio Secundario **BD**: Activa o desactiva el audio secundario (pág. 6).

Búsqueda Ins

BD **DVD** **CD** **VIDEO** **MUSIC**: Salta 30 segundos.

Repetición Ins

BD **DVD** **CD** **VIDEO** **MUSIC**: Reproduce el contenido desde 10 segundos antes.

Pase de diapositivas

PHOTO:

Muestra la velocidad del pase de diapositivas. Puede seleccionar la velocidad del pase de diapositivas entre Lento/Medio/Rápido.

Transición **PHOTO**: Muestra cómo aparece la foto en la pantalla. Puede seleccionar el tipo de transición.

Code Page **VIDEO**: Permite seleccionar el código de caracteres de los subtítulos que ha agregado al vídeo DivX (pág. 41).

Español

■ Menú de estado

Muestra varios ajustes, cómo los subtítulos, el ángulo y el número de título/capítulo/pista reproducido actualmente. Para mostrar el menú de estado, pulse **STATUS**. El menú de estado consta de los siguientes menús.

BD DVD VIDEO

Ejemplo: Iconos cuando se reproduce BD

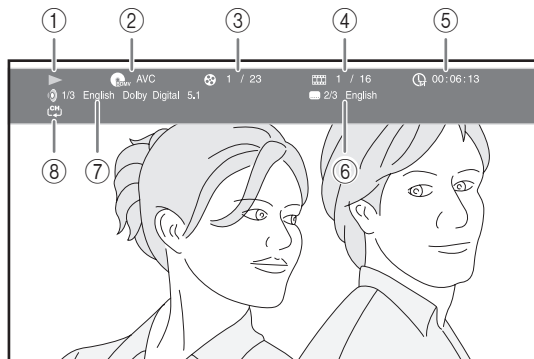

- ① **(Estado de reproducción)**
- ② **(Icono de tipo de disco/archivo de vídeo)**
- ③ **(Número de título que se reproduce):** Puede saltar al título especificado con la tecla **SEARCH** (pág. 8).
- ④ **(Número de capítulo que se reproduce):** Puede saltar al capítulo especificado con la tecla **SEARCH** (pág. 8).
- ⑤ **(Tiempo de reproducción transcurrido):** Puede saltar al punto especificado con la tecla **SEARCH** (pág. 8).
- ⑥ **(Subtítulos seleccionados actualmente):** Puede cambiar el idioma de los subtítulos con la tecla **SUBTITLE**.
- ⑦ **(Audio seleccionado actualmente):** Puede cambiar el formato o idioma de audio con la tecla **AUDIO**.
- ⑧ **(Modo repetición):** Muestra el modo repetición actual (pág. 8).

DVD CD MUSIC

Ejemplo: Iconos cuando se reproduce un archivo de música

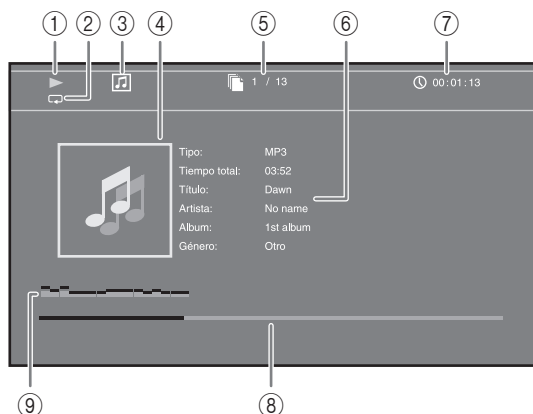

- ① **(Estado de reproducción)**
- ② **(Modo repetición):** Muestra el modo repetición actual (pág. 8).
- ③ **(Icono de tipo de disco/archivo de música)**
- ④ **(Gráficos) MUSIC:** Muestra gráficos si están contenidos en el archivo.
- ⑤ **(Número de pista/archivo que se reproduce):** Puede saltar a la pista especificada con la tecla **SEARCH** (pág. 8).
- ⑥ **(Información) MUSIC:** Muestra información musical si está contenida en el archivo.
- ⑦ **(Tiempo de reproducción transcurrido):** Puede saltar al punto especificado con la tecla **SEARCH** (pág. 8).
- ⑧ **(Barra de progreso) MUSIC:** Muestra el estado de progreso de la canción actual.
- ⑨ **(Medidor de nivel de audio):** Muestra el nivel de volumen actual.

PHOTO



- ① **(Estado de reproducción)**
- ② **(Icono de archivo de fotos)**
- ③ **(Número de archivo que se muestra)**
- ④ **(Modo repetición):** Muestra el modo repetición actual (pág. 8).
- ⑤ **(Velocidad de pase de diapositivas)**

■ Uso de Marcador **DVD VIDEO**

Le permite establecer un Marcador en un punto especificado del vídeo. Después de establecer el Marcador, puede saltar al punto utilizando esta función. Puede definir hasta 12 marcadores.

- 1 Pulse **MARKER** durante la reproducción de la película para definir el Marcador. Se muestran el número de Marcador y el estado.



- 2 Después de establecer el Marcador, pulse **DIGEST** para mostrar la barra de selección de Marcador.



- 3 Pulse **◀/▶** para seleccionar el Marcador que desee reproducir, a continuación pulse **ENTER**. Pulse **CLEAR** para eliminar el Marcador seleccionado.

Nota

- Cuando finaliza la reproducción (por ejemplo, al expulsar el disco o al presionar **■** dos veces), los marcadores se eliminan automáticamente.

■ Reproducción de programa **DVD CD**

Esta opción le permite programar el orden de reproducción de las pistas de un disco de audio o de los capítulos de DVD. Pulse **PROGRAM** durante la reproducción para mostrar la ventana PROGRAMA para programar el orden de reproducción.

Puede programar hasta 15 pistas/capítulos.

Ejemplo: Programación del orden de reproducción de pistas de CD

- 1 Pulse **PROGRAM** durante la reproducción.



- 2 Pulse **ENTER** para programar el orden de reproducción. Para un disco de audio, pulse **▲/▼** para seleccionar una pista deseada y, a continuación, pulse **ENTER**. Para un disco DVD-Vídeo, seleccione un título deseado (mostrado como TT) y capítulo (mostrado como CH) en lugar de una pista. Para borrar una pista establecida, seleccione la pista que desea borrar y, a continuación, pulse **CLEAR**. Pulse **RETURN** para cancelar la reproducción del programa.



- 3 Una vez finalizada la programación, pulse **▶** para definir e iniciar la reproducción del programa.
- 4 Para cancelar la reproducción del programa, detenga la reproducción por completo pulsando **■** dos veces.





■ Uso de la búsqueda

BD DVD CD VIDEO MUSIC



Esta opción le permite saltar a un punto específico durante la reproducción.

- 1 Pulse **SEARCH** durante la reproducción. Aparece la barra de estado.
- 2 Pulse **▲/▼/◀/▶** para seleccionar uno de los elementos siguientes, a continuación pulse **ENTER**.



BD DVD :

- Número de título (mostrado como )
- Número de capítulo (mostrado como )
- Tiempo de título transcurrido (mostrado como )
- Tiempo de capítulo transcurrido (mostrado como )

CD :

- Número de pista (mostrado como )
- Tiempo de pista transcurrido (mostrado como )
- Tiempo de disco transcurrido (mostrado como )

VIDEO MUSIC :

- Número de archivo (mostrado como )
- Tiempo de archivo transcurrido (mostrado como )

- 3 Pulse **▲/▼** o las teclas de número para definir o ajustar el valor del elemento seleccionado y pulse **ENTER** para saltar al punto especificado.
- 4 Para cerrar la barra de estado, pulse **STATUS**.

■ Disfrute de BONUSVIEW™ y BD-Live™

Este reproductor admite las funciones de reproducción de BONUSVIEW (pág. 41) (BD-ROM Perfil 1 Versión 1.1) y BD-Live (pág. 41) (BD-ROM Perfil 2).

Nota

- Las funciones y el método de reproducción varían según el disco. Siga las indicaciones del disco o del manual de usuario suministrado.

■ Utilización de la función Imagen en Imagen (reproducción de audio/vídeo secundario)

El Vídeo BD que incluye audio y vídeo secundario compatible con Imagen en Imagen se puede reproducir con audio y vídeo secundario simultáneamente como un vídeo pequeño en la esquina.

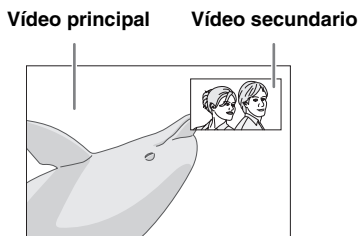

Mientras se muestra Marca PIP (PIP) o Marca Audio Secundario (CAS), pulse PIP para activar o desactivar la función Imagen en imagen.

Notas

- Para escuchar audio secundario, asegúrese de que el ajuste Salida de audio (Coaxial/Optica o HDMI) se ha definido en PCM o Recodificar (pág. 34).
- Dependiendo del disco, para escuchar audio secundario, es posible que tenga que activar el audio secundario en el menú principal del disco (pág. 7).
- Dependiendo del contenido, el audio y el vídeo secundario para Imagen en Imagen pudiera reproducirse y desaparecer automáticamente. Además, pudiera haber restricción respecto a las áreas que pueden visualizarse.

■ Utilización de la función de BD-Live™

1. Ajuste de la configuración de red (pág. 32).

2. Conecte el dispositivo de memoria USB al reproductor (pág. 16).

- Los datos de BD-Live se guardan en un dispositivo de memoria USB conectado a este reproductor. Para disfrutar de estas funciones, conecte un dispositivo de memoria USB (2 GB o superior y formateado con FAT 32/16) compatible con USB 2.0 de alta velocidad (480 Mbit/s) al puerto USB seleccionado en Almacenamiento Local (pág. 30). La configuración predeterminada es el puerto USB del panel trasero.
- La carpeta BUDA se crea automáticamente en el dispositivo de memoria USB cuando es necesario.
 - Si el espacio de almacenamiento es insuficiente, los datos no se copiarán/descargarán. Elimine datos innecesarios o utilice un nuevo dispositivo de memoria USB.
 - Puede requerirse algún tiempo para que se carguen (lectura/escritura) los datos.

Notas

- Yamaha no puede garantizar que todas las marcas de dispositivos de memoria USB funcionen con este reproductor.
- No utilice un cable de extensión USB cuando conecte un dispositivo de memoria USB al puerto USB del reproductor. El uso de un cable de extensión USB podría impedir que el reproductor funcione correctamente.

3. Reproducción del disco.

4. Ejecute BD-Live siguiendo las instrucciones del disco.



Notas

- En relación con el método de reproducción de contenidos BD-Live, etc., lleve a cabo las operaciones de acuerdo con las instrucciones del manual del disco BD.
- Para disfrutar de las funciones de BD-Live, realice la conexión de red (pág. 16) y los ajustes de Red (pág. 32).
- Consulte la “Conexión BD-Live” (pág. 32) en relación con la configuración para restringir el acceso a contenidos BD-Live.
- El tiempo que se necesita para descargar los programas que se ofrecen al dispositivo de memoria USB conectado en este reproductor depende de las velocidades de conexión a Internet y del volumen de datos de los programas.
- Los programas BD-Live suministrados a través de Internet podrían no ser capaces de mostrar la conexión dependiendo del estado (actualización) del proveedor. En tal caso, extraiga el disco y vuelva a intentarlo.
- Si la pantalla BD-Live no aparece durante un rato después de seleccionar la función BD-Live en el menú del disco BD, es posible que el dispositivo de memoria USB no tenga suficiente espacio libre. En tal caso, expulse el disco del reproductor y, a continuación, borre los datos del dispositivo de memoria USB utilizando el menú “Formato” de “Almacenamiento Local” (pág. 30).

MENÚ SETUP

El Menú SETUP permite realizar diversos ajustes y configuraciones audiovisuales en las funciones utilizando el mando a distancia.

Menú/Submenú	Elemento	Función	Página	
 Configuración General	Sistema	Protector de pantalla	Activa/desactiva el protector de pantalla.	30
		Reproducción Automática Disco	Ajusta el reproductor para que inicie automáticamente la reproducción del disco.	30
		Control HDMI	Configura el reproductor para que reciba la señal de control desde el mando a distancia de su receptor de TV/AV.	30
		Control de Red	Activa o desactiva el control a través de Ethernet.	30
		Cargar configuración por defecto	Restablece todos los ajustes a los valores predeterminados, excepto el ajuste Seguridad.	30
		Actualizar	Realiza la actualización del reproductor.	30
		Configuración Sencilla	Ajusta el idioma, la resolución y la relación de aspecto de la pantalla.	30
		Almacenamiento Local	Muestra el estado de Almacenamiento Local (pág. 30), formatea Almacenamiento Local y selecciona el puerto USB delantero o posterior de Almacenamiento Local.	30
		Mensaje Reproducción 3D	Muestra un mensaje de advertencia acerca de la reproducción de vídeo en 3D cuando este reproductor esté encendido.	30
	Idioma	OSD	Selecciona el idioma del menú en pantalla.	31
		Menú	Permite dar prioridad al idioma del menú del disco.	31
		Audio	Permite dar prioridad al idioma del audio.	31
		Subtítulo	Permite dar prioridad al idioma de los subtítulos.	31
	Reproducción	Subtítulos	Activa o desactiva los subtítulos.	31
		Marca de Angulo	Ajuste para mostrar la Marca de Angulo cuando se reproducen BD/DVD con ángulos múltiples.	31
		Marca PIP	Ajuste para mostrar la Marca PIP cuando se reproducen BD/DVD con Imagen en imagen.	31
		Marca Audio Secundario	Ajuste para mostrar la Marca Audio Secundario cuando se reproducen BD/DVD con audio secundario.	31
		DivX(R) VOD DRM	Muestra el código de registro del vídeo DivX(R).	31
		Modo DVD-Audio	Ajusta el modo DVD-Audio en DVD-Audio/DVD-Vídeo.	31
	Seguridad	Cambiar Contraseña	Permite cambiar la contraseña de Control Paterno y Código de país.	31
		Control Paterno	Establece el Control Paterno en función del contenido del disco.	31
		Código de país	Establece el Código de país.	31
	Red	Conexión a Internet	Permite definir la conexión a Internet en Permitir/Desactivar.	32
		Información	Muestra la pantalla de información de red.	32
		Prueba de conexión	Realiza la prueba de conexión de red.	32
		Configuración IP	Permite definir la configuración IP en Auto/Manual.	32
		Conexión BD-Live	Permite definir la conexión a BD-Live en Autorizada/Permitida Parcialmente/Prohibido.	32
		DLNA	Permite definir la conexión a DLNA en Permitir/Desactivar.	32
		Configuración Proxy	Permite definir la configuración proxy.	32

Menú/Submenú	Elemento	Función	Página	
 Configuración de pantalla	TV	Salida 3D	Selecciona vídeos en 3D o 2D.	32
		Pantalla de TV	Ajusta la relación de aspecto de la pantalla del televisor conectado, y ajusta la salida de vídeo.	32
		Resolución	Selecciona la resolución del vídeo de salida.	33
		Sistema de TV	Permite seleccionar el Sistema de TV entre NTSC/PAL/Multi.	33
		Color Space	Selecciona el espacio de color entre las opciones RGB/YCbCr 4:4:4/YCbCr 4:2:2/Full RGB.	33
		HDMI Deep Color	Permite seleccionar HDMI Deep Color entre 30 bits/36 bits/Desactivar.	33
		HDMI 1080p 24Hz	Activa o desactiva HDMI 1080p 24Hz.	33
		Sincronismo de labios	Ajusta el retardo entre vídeo y audio, como por ejemplo cuando el movimiento de la boca no se corresponde con la voz.	33
	Procesamiento de Video	Modo de Vídeo	Ajusta la imagen visual.	33
		Ajuste de color	Ajusta Brillo/Saturación/Tonalidad para cada color.	33
		Contraste automático	Ajusta el contraste para optimizar la imagen reproducida.	33
		Reducción de ruido	Ajusta el nivel de Reducción de ruido.	33
		Modo desentrelazado	Ajusta cómo detectar la señal de vídeo.	34
	 Configuración de audio	Salida de audio	Coaxial/Optica	Permite seleccionar el modo de salida de la toma COAXIAL/terminal OPTICAL entre Bitstream/PCM/Recodificar/Desactivar.
HDMI			Permite seleccionar el modo de salida del terminal HDMI entre Bitstream/PCM/Recodificar/Desactivar.	34
Downsampling			Permite seleccionar la frecuencia de submuestreo de la señal de audio digital entre 48k/96k/192k.	34
DRC			Define el DRC (Control de gama dinámica).	34
Salida SACD		Prioridad SACD	Selecciona un contenido cuando se reproduce un SA-CD híbrido.	34
		Salida HDMI	Selecciona el modo de salida del terminal HDMI entre DSD/PCM cuando se reproduce un SA-CD.	34
Ajuste de altavoz		Configuración	Establece la salida de audio de la toma sonido envolvente de 7.1 canales.	34
		Mezcla descendente 2 Canales	Selecciona el método de mezcla descendente de 2 canales analógico.	34
Post-procesamiento		Mezcla ascendente	Convierte la señal de audio de 2 canales en multicanal.	34
 Sistema de Información			Muestra la versión de software y la dirección MAC (pág. 42).	34

■ Ejemplo de funcionamiento del menú SETUP

Debe llamar a la pantalla de menú SETUP para realizar los ajustes en el reproductor. A continuación se explican las operaciones básicas del menú SETUP.

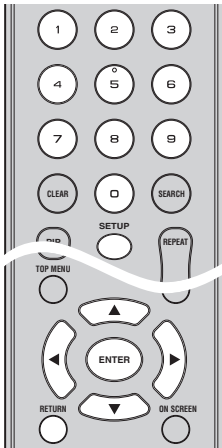

Ejemplo: Ajuste de Control Paterno

Nota

- Algunos elementos no se pueden ajustar durante la reproducción. En este caso, pulse dos veces **■** para detener la reproducción completamente antes de realizar el ajuste.

1. Muestre la pantalla de menú SETUP.

Pulse **SETUP** para mostrar la pantalla de menú SETUP. Pulse **◀/▶** para seleccionar Configuración General, a continuación pulse **ENTER** o **▼**.

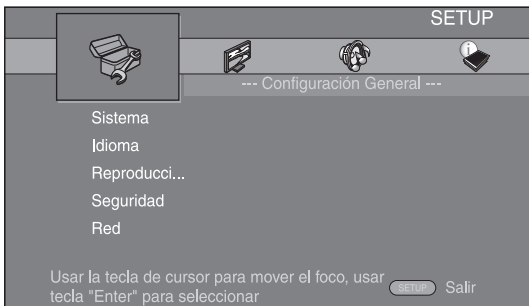

2. Seleccione un submenú.

Pulse **▲/▼** para seleccionar Seguridad, a continuación pulse **ENTER** o el cursor **▶**.

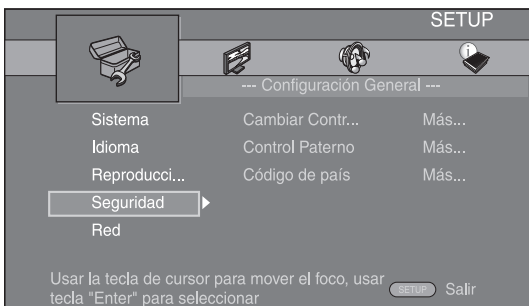

3. Seleccione un elemento del menú.

Pulse **▲/▼** para seleccionar Control Paterno, a continuación pulse **ENTER** o el cursor **▶**.

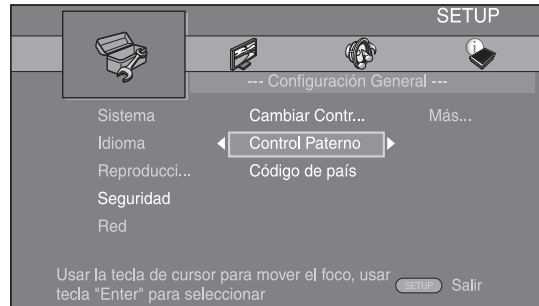

4. Introduzca la contraseña.

Introduzca la contraseña con las teclas numéricas.

- La contraseña predeterminada es 0000.
- No puede ir a la siguiente pantalla de configuración hasta que no haya introducido la contraseña correcta.
- Para cambiar la contraseña, consulte "Cambiar Contraseña" (pág. 31).

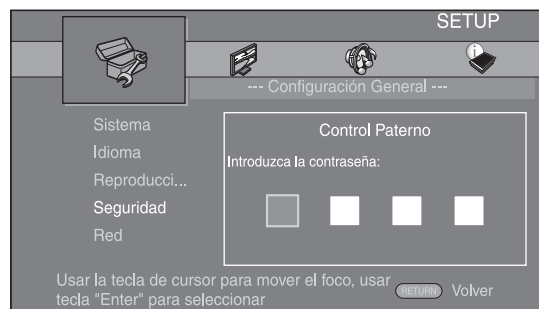

5. Seleccione un elemento siguiente.

Pulse **▲/▼** para seleccionar el nivel de Control Paterno para BD/DVD, a continuación pulse **ENTER**.



6. Salga de la pantalla del menú

Pulse **◀** para volver al menú anterior.

■ Configuración General

Los ajustes predeterminados están marcados con “*”.

Sistema

Protector de pantalla

Puede definir el protector de pantalla en activado o desactivado. Cuando se activa, el reproductor pasará a modo de protector de pantalla si no se utiliza durante 3 minutos. Posteriormente, el reproductor pasará a modo de espera cuando no se utilice durante 6 minutos.

Activar*, Desactivar

Reproducción Automática Disco

Puede activar o desactivar la Reproducción Automática Disco. Cuando se activa, el disco se reproducirá automáticamente después de cargarlo.

Activar*, Desactivar

Control HDMI

Puede ajustar el reproductor para que reciba una señal de control desde un receptor de TV/AV compatible con la función Control HDMI a través de un cable HDMI (pág. 12).

Activar, Desactivar*

Utilización de la función Control HDMI

Con la función de Control HDMI, puede operar interactivamente este reproductor con su televisor (si soporta la función de Control HDMI).

Cuando se conecta el reproductor al televisor compatible con la función de Control HDMI mediante un cable HDMI y se activa el Control HDMI en el menú SETUP (pág. 30), puede realizar las funciones indicadas a continuación.

- **Función de selección de entrada automática**
Cuando inicie la reproducción en este reproductor, el selector de entrada del televisor (y de un receptor A/V si este reproductor está conectado con el televisor mediante un receptor A/V) cambia automáticamente a este reproductor. La alimentación del televisor se enciende automáticamente dependiendo del televisor.
- **Función de apagado automático**
Si apaga el televisor cuando este reproductor está en modo de parada y no se visualiza menú SETUP, este reproductor también se apagará automáticamente.

Notas

- Es posible que la función de Control HDMI no funcione correctamente dependiendo del televisor.
- Otras funciones, aparte de las que se han mencionado anteriormente, pueden funcionar según el televisor o receptor A/V.
- Para hacer que la función de Control HDMI esté disponible, configure los ajustes de la función de Control HDMI en TODOS los componentes (este reproductor, el televisor y el receptor de A/V). Es posible que también sean necesarias determinadas operaciones.
- Cada función se puede configurar de forma independiente para activar o desactivar según el televisor.
- Consulte los detalles relacionados con la configuración en los manuales de funcionamiento que se proporcionan con el televisor y/o el receptor A/V.
- Cuando está activado, el consumo de energía durante el modo de espera aumenta por la función de control de HDMI.

Control de Red

Puede activar el control a través de Ethernet. Este reproductor utiliza el protocolo Yamaha Network Control (YNC).

Activar, Desactivar*

Notas

- Cuando está activado, el consumo de energía durante el modo de espera aumenta por la función de control de red.
- Cuando está activado, se reduce el tiempo de inicio del sistema.

Cargar configuración por defecto

Puede restablecer todos los ajustes de este reproductor al ajuste predeterminado, excepto el ajuste Seguridad (pág. 31). Para conocer detalles sobre los ajustes predeterminados, consulte las páginas 27-34.

Actualizar

Puede actualizar el software manualmente desde Disc, USB Storage o Network. Para conocer detalles sobre la actualización de software, consulte “ACTUALIZACIÓN DE SOFTWARE” (pág. 37).

Configuración Sencilla

Puede realizar la Configuración Sencilla (pág. 18).

Almacenamiento Local

Puede mostrar información de Almacenamiento Local, formatear Almacenamiento Local y seleccionar USB Frontal/USB Trasera para guardar los datos de BD-Live. Para formatear (vaciar) la carpeta “BUDA” en el dispositivo de memoria USB, seleccione Información y pulse **ENTER** mientras “Formato” está seleccionado en la pantalla.

USB Frontal, USB Trasera*

Consejo

- Almacenamiento Local se utiliza como memoria auxiliar cuando se reproduce el disco Blu-ray.

Mensaje Reproducción 3D

Puede activar o desactivar un mensaje de advertencia acerca de la reproducción de vídeo en 3D que aparezca en el televisor cuando este reproductor está activado.

Activar*, Desactivar

Idioma

OSD

Puede seleccionar el idioma de pantalla, es decir, el menú o los mensajes mostrados en pantalla como, por ejemplo, el menú SETUP.

English*, Français, Español, Deutsch, Italiano, Svenska, Nederlandse, Русский

Menú

Puede dar prioridad al idioma del menú del disco.

English*, Français, 中文, Español, Deutsch, Italiano, Nederlandse, Portugués, Danés, Svenska, Finlandés, Noruega, Русский, Corea, Japonés, Más

Audio

Puede dar prioridad al idioma del audio para la reproducción de BD/DVD. Para obtener detalles sobre la configuración de elementos, consulte "Menú" (pág. 31).

Subtítulo

Puede dar prioridad al idioma de los Subtítulo.

English, Français, 中文, Español, Deutsch, Italiano, Nederlandse, Portugués, Danés, Svenska, Finlandés, Noruega, Русский, Corea, Japonés, Más, Desactivar*

Reproducción

Subtítulos

Puede ajustar que se visualicen los subtítulos (pág. 42) cuando se reproducen BD/DVD con subtítulos.

Activar, Desactivar*

Marca de Angulo

Puede ajustar la visualización de Marca de Angulo () cuando se reproducen BD/DVD con ángulos múltiples.

Activar*, Desactivar

Marca PIP

Puede ajustar la visualización de Marca PIP () cuando se reproducen BD (pág. 26) con Imagen en imagen.

Activar*, Desactivar

Marca Audio Secundario

Puede ajustar la visualización de Marca Audio Secundario () cuando se reproducen BD con audio secundario.

Activar*, Desactivar

DivX(R) VOD DRM

Puede mostrar el código de registro del vídeo DivX(R).

Modo DVD-Audio

Algunos discos DVD-Audio contienen información de DVD-Vídeo además del contenido de DVD-Audio. Puede seleccionar el modo DVD-Audio o DVD-Vídeo.

DVD-AUDIO* Se reproducen los contenidos de DVD-Audio y Vídeo. En función del disco, tal vez solamente pueda reproducirse el contenido de DVD-Audio.

DVD-VÍDEO Solamente se reproduce el contenido de DVD-Vídeo.

Nota

- Este ajuste solamente está disponible si no hay ningún disco cargado.

Seguridad

Cambiar Contraseña

Puede ajustar la contraseña para cambiar el nivel de Control Paterno y Código de país. Consulte "Control Paterno" (pág. 31) y "Código de país" (pág. 31).

Notas

- La contraseña predeterminada es 0000.
- Si olvida la contraseña, consulte "RESOLUCIÓN DE PROBLEMAS" (pág. 38) y configure todos los ajustes de Seguridad en sus valores predeterminados.

Control Paterno

En algunos discos de BD/DVD, existe un nivel de control para la visualización del disco en función de la edad del espectador. Puede ajustar el Control Paterno mostrado en pantalla en función del contenido del disco.

Es necesario introducir la contraseña (consulte "Cambiar Contraseña" en pág. 31) antes de ajustar los niveles de Control Paterno.

Después de ajustar el Control Paterno, si reproduce un disco con un nivel más alto del nivel de Control Paterno actual o si desea cambiar el nivel de Control Paterno, aparecerá un cuadro de diálogo solicitando que introduzca la contraseña.

Desactivar*, 1 a 8

Código de país

Puede ajustar el Código de país en el que vive. Es necesario introducir la contraseña (consulte "Cambiar Contraseña" en pág. 31) antes de ajustar el Código de país. Este parámetro podría utilizarse para la calificación de Control Paterno y reproducción de discos.

Red

Conexión a Internet

Defina este elemento en Permitir cuando utilice BD-Live (pág. 26), DLNA (pág. 21) y actualice el software desde la red (pág. 37).

Permitir*, Desactivar

Información

Puede mostrar la pantalla de información de red. En esta pantalla puede ver información de Interfaz (Ethernet), Tipo de dirección, Dirección IP, Máscara de subred, Puerta de enlace predeterminada y DNS.

Prueba de conexión

Puede realizar una prueba de conexión a Internet. Si la prueba falla, compruebe la “Configuración IP” (pág. 32) y vuelva a realizar la prueba.

Configuración IP

Puede configurar los ajustes de red.

- Auto*** Seleccione este valor para configurar automáticamente los ajustes de red de este reproductor con el servidor DHCP.
- Manual** Seleccione este valor para configurar los ajustes de red (Dirección IP, Máscara de subred, Default Gateway y DNS) manualmente.

Consejos

- **Teclas numéricas** Permiten introducir caracteres.
- **◀▶** Permiten desplazar el elemento resaltado.
- **CLEAR** Permite eliminar un carácter.
- **ENTER** Permite guardar los valores y salir del menú.

Conexión BD-Live

Puede definir la restricción de acceso al contenido de BD-Live.

- Autorizada** Permite que todos los discos de BD-Live se conecten a la red.
- Permitida Parcialmente*** Permite únicamente los discos con certificación de propietario.
- Prohibido** Prohíbe que todos los discos de BD-Live se conecten a la red.

DLNA

Puede definir la función DLNA (pág. 21) en Permitir/Desactivar. Cuando no utilice la función DLNA, defínala en Desactivar.

Permitir*, Desactivar

Configuración Proxy

Puede definir Configuración Proxy. Defínalo en Desactivar para uso normal. Seleccione Permitir para definir la configuración del proxy.

- Permitir** Activa los ajustes del host y el puerto proxy.
- Desactivar*** Desactiva el servidor proxy. Seleccione esta opción cuando no utilice el servidor proxy.

Host Proxy Define el host proxy.

Puerto proxy Define el puerto proxy.

Configuración de pantalla

Los ajustes predeterminados están marcados con “* ”.

TV

Salida 3D

Puede seleccionar salida de vídeo en 3D o 2D desde este reproductor.

- Auto*** Este reproductor selecciona automáticamente vídeos en 3D o 2D.
- Desactivar** Este reproductor siempre selecciona vídeos en 2D.

Nota

- Aunque establezca “Salida 3D” en “Auto” y reproduzca un disco 3D de Blu-ray, este reproductor selecciona imágenes en 2D en función de la conexión y del ajuste del televisor, etc. (pág. 12).

Pantalla de TV

Puede ajustar la relación de aspecto de la pantalla del televisor conectado, y ajustar la salida de vídeo.

Si cambia de televisor, por ejemplo, porque ha adquirido uno nuevo, y la relación de aspecto de la pantalla del televisor conectado cambia, también tendrá que cambiar el ajuste Pantalla de TV.

- 16:9 Lleno** Selecciónelo cuando conecte el reproductor a un televisor con pantalla 16:9. Cuando se reproduce vídeo con una relación de aspecto 4:3, el vídeo se muestra como aparece en la ilustración.
- 16:9 Normal*** Selecciónelo cuando conecte el reproductor a un televisor con pantalla 16:9. Cuando se reproduce vídeo con una relación de aspecto 4:3, el vídeo se muestra como aparece en la ilustración.
- 4:3 Panorámico** Selecciónelo cuando conecte el reproductor a un televisor con pantalla 4:3. Cuando se reproduce vídeo con una relación de aspecto 16:9, el vídeo se muestra como aparece en la ilustración.
- 4:3 Buzón** Selecciónelo cuando conecte el reproductor a un televisor con pantalla 4:3. Cuando se reproduce vídeo con una relación de aspecto 16:9, el vídeo se muestra como aparece en la ilustración.

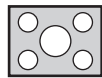
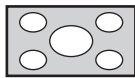
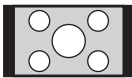
Tamaño de imagen original	En televisor 16:9 (pantalla panorámica)	
	16:9 Lleno	16:9 Normal
 4:3		

Tamaño de imagen original	En televisor 4:3	
	4:3 Panorámico	4:3 Buzón
 16:9		

Resolución

Puede seleccionar la resolución de salida de vídeo entre Auto, 480i/576i, 480p/576p, 720p, 1080i y 1080p. Cuando se define en Auto, la resolución se ajusta a la resolución máxima según el televisor conectado. Para obtener detalles adicionales sobre los formatos de salida, consulte “Acerca de los formatos de salida de vídeo” (pág. 36).

Auto*, **480i/576i**, **480p/576p**, **720p**, **1080i**, **1080p**

Nota

- Para emitir audio HD (como Dolby TrueHD o DTS-HD Master Audio) desde un terminal HDMI, configure Resolución como Auto o un ajuste superior a 720p.

Sistema de TV

Puede seleccionar el valor de Sistema de TV entre PAL, NTSC y Multi. Ajuste el mismo valor de Sistema de TV que su televisor. Para obtener detalles adicionales sobre los formatos de salida, consulte “Acerca de los formatos de salida de vídeo” (pág. 36).

NTSC, PAL*, **Multi** (Modelos de Australia, Asia, Reino Unido, Europa y Rusia)

NTSC*, **PAL**, **Multi** (Modelos de EE. UU., Canadá, América Central y del Sur, Taiwán y Corea)

Color Space

Puede seleccionar la salida Color Space (pág. 41) desde HDMI. Esta función está disponible cuando el reproductor se conecta con un cable HDMI.

RGB Permite la salida de la señal de vídeo con el rango normal de señal.

YCbCr 4:4:4* Permite definir Color Space en YCbCr 4:4:4.

YCbCr 4:2:2 Permite definir Color Space en YCbCr 4:2:2.

Full RGB Si se ha configurado RGB y el blanco y negro de la pantalla está demasiado difuminado, seleccione este elemento. Esta opción se aplica si un componente conectado admite el intervalo RGB 0-255.

Nota

- Esta función sólo está disponible en televisores que admitan dicha función.

HDMI Deep Color

Si su televisor y/o receptor de A/V es compatible con Deep Color (pág. 41), ajuste este elemento según su televisor o receptor de A/V. Esta función está disponible cuando el reproductor se conecta con un cable HDMI.

30 bits, **36 bits**, **Desactivar***

HDMI 1080p 24Hz

Permite la salida del Vídeo BD codificado con una velocidad de fotogramas de 24 Hz en HDMI 1080p 24Hz. Con esta función es posible que disponga de una reproducción de vídeo más suave. Esta función está disponible si el receptor de A/V o el televisor admiten esta función y el reproductor está conectado con un cable HDMI. Para obtener detalles adicionales sobre los formatos de salida, consulte “Acerca de los formatos de salida de vídeo” (pág. 36).

Auto*, **Desactivar**

Nota

- Este parámetro está desactivado cuando la resolución de salida es diferente de 1080p.

Sincronismo de labios

Puede definir o ajustar la función Sincronismo de labios (pág. 42).

Auto* Este reproductor ajusta la función Sincronismo de labios automáticamente.

Manual Puede ajustar la función Sincronismo de labios manualmente. Puede establecer el retraso del audio para contenido 2D y 3D de forma independiente.

2D

3D

Desactivar Este reproductor no ajusta la función Sincronismo de labios.

Procesamiento de Vídeo

Modo de Vídeo

Puede seleccionar Modo de Vídeo más abajo.

Estándar* La imagen es más natural y equilibrada. Este modo es adecuado para usos normales.

Rico La imagen es más viva e intensa.

Cine La imagen es adecuada para ver películas en una habitación a oscuras.

Particularizado Puede ajustar la imagen visual manualmente. Pulse ▲/▼ para seleccionar el parámetro, a continuación pulse ◀/▶ para ajustar la figura.

Brillo

Ajusta el brillo global de la imagen.

Nitidez

Ajusta la nitidez de los elementos del vídeo.

Tonalidad

Ajusta el tono de la imagen proyectada.

Saturación

Ajusta la riqueza de color de la imagen proyectada.

Contraste

Ajusta las áreas claras (niveles blancos) de la imagen.

CTI

Suaviza los bordes de las imágenes en color. De este modo, las imágenes en color se distinguen más.

Los valores predeterminados son 0.

Ajuste de color

Ajusta Brillo/Saturación/Tonalidad para cada color (Rojo/Verde/Azul/Amarillo/Cian/Magenta). Para utilizar esta función, configure Modo de Vídeo como Particularizado. Para obtener detalles sobre la configuración de elementos, consulte “Modo de Vídeo” (pág. 33).

Los valores predeterminados son 0.

Contraste automático

Ajusta el contraste para optimizar la imagen reproducida. Para utilizar esta función, configure Modo de vídeo como Particularizado.

Desactivar*, **Activar**

Reducción de ruido

Puede configurar la Reducción de ruido a un nivel entre 0 y 3. 0 equivale a desactivado y 3 es el nivel máximo.

0*, **1**, **2**, **3**

Modo desentrelazado

Puede seleccionar cómo detectar la señal de vídeo. Defínalo en Auto para uso normal. Cuando aparece en la pantalla un ruido de desgarro horizontal, configure esta opción en Película/Vídeo para eliminar el ruido.

Auto*, Película, Vídeo

■ Configuración de audio

Los ajustes predeterminados están marcados con “*”.

Salida de audio

Coaxial/Optica

Puede seleccionar el modo de salida de la toma COAXIAL y del terminal OPTICAL. Para obtener detalles adicionales sobre los formatos de salida, consulte “Formatos de salida de audio” (pág. 35).

Bitstream Permite la salida de la señal digital sin ningún procesamiento. No se produce la salida del audio secundario.

PCM Permite la salida de PCM de 2 canales.

Recodificar* Permite la salida de Bitstream con audio secundario.

Desactivar Silencia el sonido.

HDMI

Puede seleccionar el modo de salida del terminal HDMI. Para obtener detalles sobre la configuración de elementos, consulte “Coaxial/Optica” (pág. 34). Para obtener detalles adicionales sobre los formatos de salida, consulte “Formatos de salida de audio” (pág. 35).

Bitstream*, PCM, Recodificar, Desactivar

Nota

- Para emitir audio HD (como Dolby TrueHD o DTS-HD Master Audio) desde un terminal HDMI, configure Resolución como Auto o un ajuste superior a 720p (pág. 33).

Downsampling

Puede seleccionar la frecuencia de submuestreo de la señal de audio digital. Esta función está activa para la salida de señal de audio desde la toma COAXIAL/terminal OPTICAL.

48k* La tasa de muestreo más alta de la salida PCM digital es 48 kHz.

96k La tasa de muestreo más alta de la salida PCM digital es 96 kHz.

192k La tasa de muestreo más alta de la salida PCM digital es 192 kHz.

DRC

Puede activar, desactivar o poner en modo Auto el DRC (Control de gama dinámica) (pág. 41). Cuando se define en Auto, DRC se enciende automáticamente para una fuente con información DRC en formato Dolby TrueHD. DRC hace que los sonidos fuertes como oclusivos suenen más bajo y que las conversaciones sean más audibles. Resulta útil cuando se ven películas de noche.

Desactivar*, Activar, Auto

Salida SACD

Prioridad SACD

Puede seleccionar un contenido reproducido desde datos multicanal o estéreo (2 canales) si se carga un SA-CD híbrido (pág. 4) o los dos.

Multi-ch*, 2-ch

Salida HDMI

Puede seleccionar la salida de la señal de audio desde el terminal HDMI cuando se reproduce un SA-CD.

DSD* Emite una señal DSD en bruto. Al conectar el reproductor a un receptor A/V compatible con DSD, esta puede resultar una opción útil.

PCM Emite una señal PCM descodificada por este reproductor.

Ajuste de altavoz

Configuración

Puede definir la salida de sonido envolvente de 7.1 canales dependiendo del altavoz o amplificador conectado.

1 Pulse ▲/▼ para seleccionar el altavoz que desea configurar y, a continuación pulse **ENTER**.

2 Ajuste las cifras siguientes. En función del altavoz seleccionado algunos elementos no aparecen.

Tamaño Cuando la parte del altavoz de graves del altavoz mide 16 cm o más, seleccione Grande. Si es inferior a 16 cm, seleccione Pequeño.

Grande*, Pequeño

Trim -12 a 0 dB (en pasos de 0,5 dB)

La configuración predeterminada es 0 dB.

Retraso 0,5 a 10 m (en pasos de 0,5 m)

La configuración predeterminada es 3 m.

Desactivar Cuando el altavoz seleccionado no se utiliza, seleccione Sí.

Sí, No*

3 Pulse **RETURN** para volver a la selección del altavoz.

Mezcla descendente 2 Canales

Puede seleccionar 2 canales analógico como método de mezcla descendente desde Estéreo o Lt/Rt.

Estéreo* Cambia la salida del canal a estéreo, con lo que solamente se emite sonido desde los dos altavoces frontales.

Lt/Rt Seleccione este elemento si la unidad está conectada a un descodificador Dolby Pro Logic. El sonido de los altavoces posteriores se mezcla con el sonido estéreo de 2 canales.

Post-procesamiento

Mezcla ascendente

Permite convertir la señal de audio de 2 canales en multicanal. Para realizar esta conversión, seleccione NEO6, y seleccione el modo Cinema o Music.

Desactivar*, NEO6

■ Sistema de Información

Se muestran la versión de software y la dirección MAC (pág. 42).

■ Formatos de salida de audio

Formato de origen		HDMI			COAXIAL/OPTICAL			MIXED 2CH/ Sonido envolvente de 7.1 canales
		Bitstream	PCM	Recodificar	Bitstream	PCM	Recodificar	
PCM 2 canales		PCM 2 canales			PCM 2 canales			2 canales
PCM 5.1 canales		PCM 5.1 canales			PCM 2 canales			2 canales/ 5.1 canales
PCM 7.1 canales		PCM 7.1 canales			PCM 2 canales			2 canales/ 7.1 canales
Dolby Digital	con AS* o SCB**	Dolby Digital	PCM hasta 5.1 canales	Dolby Digital	Dolby Digital	PCM 2 canales	Dolby Digital	2 canales/ 5.1 canales
Dolby Digital Plus	con AS* o SCB**	Dolby Digital Plus	PCM hasta 7.1 canales	Dolby Digital Plus	Dolby Digital	PCM 2 canales	Dolby Digital	2 canales/ 7.1 canales
				Dolby Digital				
Dolby TrueHD	con AS* o SCB**	Dolby TrueHD	PCM hasta 7.1 canales	Dolby TrueHD	Dolby Digital	PCM 2 canales	Dolby Digital	2 canales/ 7.1 canales
				Dolby Digital				
DTS	con AS* o SCB**	DTS	PCM hasta 5.1 canales	DTS	DTS	PCM 2 canales	DTS	2 canales/ 5.1 canales
DTS HD High Resolution	con AS* o SCB**	DTS HD High Resolution	PCM hasta 7.1 canales	DTS HD High Resolution	DTS	PCM 2 canales	DTS	2 canales/ 7.1 canales
				DTS				
DTS-HD Master Audio	con AS* o SCB**	DTS-HD Master Audio	PCM hasta 7.1 canales	DTS-HD Master Audio	DTS	PCM 2 canales	DTS	2 canales/ 7.1 canales
				DTS				

* “AS” es audio secundario.

** “SCB” es el sonido clic del botón, el efecto de sonido de los menús emergentes, etc.

Formatos de salida SA-CD

Ajustes de salida SACD		HDMI	COAXIAL/OPTICAL	MIXED 2CH/7.1 canales sonido envolvente
Prioridad SACD	Salida HDMI			
Multi-ch	DSD	DSD hasta 5.1 canales	Sin salida	2 canales/5.1 canales
	PCM	PCM hasta 5.1 canales	Sin salida	2 canales/5.1 canales
2-ch	DSD	DSD 2 canales	Sin salida	2 canales/2 canales
	PCM	PCM 2 canales	Sin salida	2 canales/2 canales

Notas

- Si Coaxial/Optica o HDMI se define en Bitstream, no se produce la salida de audio secundario. (pág. 34)
- Para emitir audio HD (como Dolby TrueHD o DTS-HD Master Audio) desde un terminal HDMI, configure Resolución como Auto o un ajuste superior a 720p (pág. 33).
- Para la reproducción de SA-CD, la configuración de Ajuste del altavoz (pág. 34) solamente tiene efecto si Salida HDMI está ajustada en PCM.

■ Acerca de los formatos de salida de vídeo

Si Sistema de TV se define en NTSC

	Resolución	Auto	480i/576i	480p/576p	720p	1080i	1080p	
							24 Hz	Otros
HDMI	Reproducción de BD	Máx.	Máx.	Máx.	720p 60 Hz	1080i 60 Hz	1080p 24 Hz	1080p 60 Hz
	otros						1080p 60 Hz	
COMPONENT	Reproducción de DVD comercial	480i	480i	480p	480p	480p	480p	
	Reproducción de BD			480i	480i	480i	desactivado	480i
	otros			480p	720p 60 Hz *	1080i 60 Hz *	1080i 60 Hz *	
VIDEO	Reproducción de BD	480i	480i	480i	480i	480i	desactivado	480i
	otros						480i	

* En función del disco o del contenido, este reproductor permite la salida de señal de vídeo de 480p.

Si Sistema de TV se define en PAL

	Resolución	Auto	480i/576i	480p/576p	720p	1080i	1080p	
							24 Hz	Otros
HDMI	Reproducción de BD	Máx.	Máx.	Máx.	720p 50 Hz	1080i 50 Hz	1080p 24 Hz	1080p 50 Hz
	otros						1080p 50 Hz	
COMPONENT	Reproducción de DVD comercial	576i	576i	576p	576p	576p	576p	
	Reproducción de BD			576i	576i	576i	desactivado	576i
	otros			576p	720p 50 Hz *	1080i 50 Hz *	1080i 50 Hz *	
VIDEO	Reproducción de BD	576i	576i	576i	576i	576i	desactivado	576i
	otros						576i	

* En función del disco o del contenido, este reproductor permite la salida de señal de vídeo de 576p.

Si Sistema de TV se define en Multi

Si Sistema de TV está configurado como Multi, la salida de la señal de vídeo tiene la misma frecuencia que la fuente. Consulte las tablas anteriores para obtener información sobre la configuración de frecuencia del televisor y la resolución de la señal de vídeo de salida.

Si se muestra una pantalla de menú como, por ejemplo, SETUP la salida de la señal de vídeo tiene la misma frecuencia que el origen.

Notas

- “Máx.” en la tabla significa que la resolución se ha definido en la resolución máxima admitida por el televisor conectado.
- El parámetro HDMI 1080p 24Hz está desactivado cuando la resolución de salida es diferente de 1080p.
- Cuando este reproductor permite la salida de vídeo de 1080p 24 Hz desde HDMI, no se emiten señales desde las tomas COMPONENT y VIDEO.
- Cuando se reproduce un DVD comercial con salida de componente, la resolución máxima es 480p/576p.
- Cuando Sistema de TV se define en NTSC y el origen de vídeo no es 60 Hz, la salida de vídeo se convierte a 60 Hz.
- Cuando Sistema de TV se define en PAL y el origen de vídeo no es 50 Hz, la salida de vídeo se convierte a 50 Hz.

ACTUALIZACIÓN DE SOFTWARE

Algunos de los discos BD recién lanzados no se pueden reproducir a menos que actualice el software del reproductor a la versión más reciente. Le recomendamos la actualización para que el reproductor funcione con el software más actual.

Para comprobar la disponibilidad de una actualización de software, visite

<http://download.yamaha.com/downloads/service/top/?site=europe.yamaha.com&language=en>

Consejo

- La actualización del software se inicia automáticamente tras cargar el disco que contiene el paquete de actualización.

Notas

- No saque el disco/dispositivo de memoria USB, no ponga el reproductor en modo de espera ni desenchufe el cable de alimentación o el cable LAN mientras se lleva a cabo la actualización de software.

■ Actualización del software

1. Prepare la actualización de software.

Si actualiza el software desde Disc/USB Storage:

- ① Guarde el paquete de archivos de actualización en la carpeta correspondiente en el disco/dispositivo de memoria USB. Para más información, consulte el documento de procedimientos adjunto con el paquete de archivos de actualización.
- ② Cargue el disco o conecte el dispositivo de memoria USB.
Al cargar el disco, la actualización de software se inicia automáticamente. Omita el paso 2.

Si actualiza el software desde Network:

Confirme que el reproductor está conectado a la red.

2. Seleccione el método de actualización e inicie la actualización desde el menú SETUP.

- ① Pulse **SETUP** para mostrar la pantalla de menú SETUP.
- ② Seleccione Configuración General → Sistema → Actualizar.

- ③ Seleccione el elemento que contiene el paquete de archivos de actualización desde Disc/USB Storage/Network.

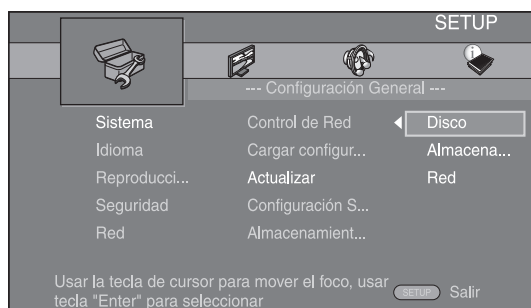

3. El sistema buscará el paquete de archivos de actualización.

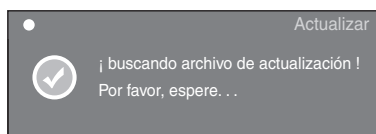

4. Pulse ENTER para iniciar la actualización.

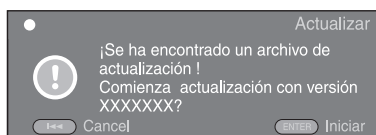

5. La actualización se ha completado. El sistema se reiniciará.





RESOLUCIÓN DE PROBLEMAS

Consulte la tabla inferior cuando el equipo no funcione correctamente. Si el problema que usted tiene no aparece en la lista inferior o las instrucciones no le sirven de ayuda, apague este reproductor, desenchufe el cable de alimentación y póngase en contacto con un centro de servicio o concesionario Yamaha autorizado.

■ Alimentación

Problema	Causas posibles y soluciones
No hay alimentación.	<ul style="list-style-type: none"> – Conecte correctamente el cable de alimentación de CA. – Pulse  en el panel delantero para encender la alimentación.
La alimentación del reproductor está apagada.	<ul style="list-style-type: none"> – La alimentación se desconectará automáticamente pasados 10 minutos continuos de inactividad (sin reproducción).

■ Funcionamiento básico

Problema	Causas posibles y soluciones
El mando a distancia no funciona.	<ul style="list-style-type: none"> – Utilice el mando a distancia dentro de su alcance operativo. (pág. 5) – Cambie las pilas. (pág. 5) – Compruebe la configuración de ID de la unidad principal y el mando a distancia. (pág. 9)
Las teclas no funcionan.	<ul style="list-style-type: none"> – Mantenga pulsado  en el panel delantero durante unos 5 segundos para reiniciar el reproductor. – Para reiniciar completamente el reproductor, desenchufe el cable de alimentación de la toma de CA durante 10 segundos o más, vuelva a enchufarlo y, a continuación, encienda el reproductor.
Se ha olvidado la contraseña.	<ul style="list-style-type: none"> – Mantenga pulsado  y  en el panel delantero a la vez si no hay ningún disco insertado y con la reproducción detenida para situar el reproductor en la configuración predeterminada (el ajuste de Seguridad (pág. 31) también se restablece). Una vez que la alimentación se desconecte automáticamente, pulse  para volver a conectarla.

■ Reproducción de disco

Problema	Causas posibles y soluciones
El reproductor no puede reproducir un disco.	<ul style="list-style-type: none"> – Extraiga el disco y límpielo. (pág. 4) – Asegúrese de que se ha cargado correctamente el disco (alineado en la bandeja portadiscos y con la cara de la etiqueta hacia arriba). (pág. 4) – Utilice un disco admitido por el reproductor. (pág. 3) – Extraiga el disco y compruebe si es un disco admitido por el reproductor o no. (pág. 3) – Compruebe el código de región. (pág. 3) – Compruebe si el disco está defectuoso probando con otro disco. – Los discos CD-R/RW, DVD+R/RW/R DL y DVD-R/RW/R DL deben estar finalizados. (pág. 3)
El vídeo se para.	<ul style="list-style-type: none"> – El reproductor se parará si detecta golpes o vibraciones.
El reproductor hace un sonido de chasquido cuando comienza la reproducción o al cargar un disco.	<ul style="list-style-type: none"> – Estos sonidos no son averías sino condiciones normales de funcionamiento del reproductor.

■ Imagen

Problema	Causas posibles y soluciones
No hay imagen.	<ul style="list-style-type: none"> - Asegúrese de que los cables están correctamente conectados. (pág. 10) - Asegúrese de que el televisor o receptor de A/V conectado está ajustado a la entrada correcta. (pág. 10) - Conecte el reproductor al televisor con la toma VIDEO (pág. 13) mediante el cable de clavijas de vídeo suministrado y definiendo correctamente la Resolución. (pág. 33) - El sistema de TV está mal ajustado. Mantenga pulsado DIMMER en el mando a distancia para restablecer la configuración predeterminada del sistema de TV.
La pantalla se congela y las teclas de operación no responden.	<ul style="list-style-type: none"> - Pulse ■ y, después, reinicie la reproducción. - Desconecte la alimentación y conéctela de nuevo. - Mantenga pulsado ⏻ en el panel delantero durante unos 5 segundos para reiniciar el reproductor.
La salida de vídeo no tiene la resolución deseada.	<ul style="list-style-type: none"> - Ajuste la resolución deseada. (pág. 33)
El vídeo de ancho horizontal aparece estirado verticalmente, o aparecen bandas negras en las partes superior e inferior de la pantalla. O el vídeo 4:3 aparece estirado horizontalmente.	<ul style="list-style-type: none"> - Cambie la relación de aspecto del televisor. (pág. 32)
Aparece ruido cuadrado (mosaicos) en la pantalla.	<ul style="list-style-type: none"> - Se podrían ver bloques en las imágenes en escenas que contengan movimientos rápidos debido a las características de la tecnología de compresión de imagen digital.
La pantalla de reproducción se perturbará si se graba vídeo DVD en una videogradora, o se reproduce a través de una videogradora.	<ul style="list-style-type: none"> - Este reproductor cumple con la protección contra copias analógicas. Algunos discos contienen una señal de prohibición de copia. Si intenta reproducir tales discos a través de una videogradora, o grabar a una videogradora y reproducir la señal, la protección contra copia impedirá la reproducción normal.
No hay salida de audio o las imágenes no se reproducen adecuadamente.	<ul style="list-style-type: none"> - En algunos discos en los que se ha grabado contenido protegido por derechos de autor es posible que no haya salida de audio o que las imágenes no se reproduzcan adecuadamente.

■ Sonido

Problema	Causas posibles y soluciones
No hay sonido o está distorsionado.	<ul style="list-style-type: none"> - Compruebe que el cable de audio está correctamente conectado. (pág. 10) - No hay sonido durante el modo de reproducción fija, cámara lenta, avance rápido y retroceso rápido. (pág. 7) - El audio puede no salir dependiendo del estado de grabación del audio, por ejemplo, cuando se haya grabado como contenido de audio, audio que no sea una señal de audio o audio no estándar. (pág. 3)
Los canales de audio izquierdo y derecho están invertidos o el sonido sólo sale por uno de ellos.	<ul style="list-style-type: none"> - Compruebe la conexión de audio. (pág. 10)
No hay salida de audio o las imágenes no se reproducen adecuadamente.	<ul style="list-style-type: none"> - En algunos discos en los que se ha grabado contenido protegido por derechos de autor es posible que no haya salida de audio o que las imágenes no se reproduzcan adecuadamente.
No se puede escuchar el tipo de audio que se desea y/o el número de canales.	<ul style="list-style-type: none"> - Consulte el ajuste Salida de audio y "Formatos de salida de audio". (pág. 34, 35)
No se escucha el sonido de PIP (audio secundario).	<ul style="list-style-type: none"> - Ajuste Coaxial/Optica o HDMI en PCM/Recodificar. (pág. 34) - Para escuchar el audio secundario, pulse 2ND AUDIO. (pág. 6) - Dependiendo del disco, es posible que tenga que activar el audio secundario en el menú principal del disco (pág. 7)

■ Red

Problema	Causas posibles y soluciones
No se puede conectar a Internet.	<ul style="list-style-type: none"> - Conecte correctamente el cable de red. - Encienda el equipo conectado como, por ejemplo, un módem o enrutador de banda ancha. - Conecte correctamente el módem y/o el enrutador de banda ancha. - Configure correctamente el valor o valores de la red. Compruebe "Red". (pág. 32)
No se pueden descargar contenidos BD-Live.	<ul style="list-style-type: none"> - Conecte correctamente el cable de red. (pág. 16) - Conecte el dispositivo de memoria USB correctamente. Compruebe que el dispositivo de memoria USB está conectado al puerto USB del reproductor. (pág. 16) - Compruebe si el disco BD admite BD-Live. - Compruebe el ajuste de "Conexión a Internet". (pág. 32) - Conecte el dispositivo de memoria USB formateado en FAT16 o FAT32. - Se recomienda conectar el dispositivo de memoria USB con al menos 2 GB de espacio libre. Si no hay suficiente espacio libre, formatee el dispositivo de memoria USB. (pág. 30) - Consulte el manual del usuario suministrado del disco o póngase en contacto con el fabricante del disco.
No se puede detectar el servidor DLNA.	<ul style="list-style-type: none"> - Conecte correctamente el cable de red. - Encienda el equipo conectado como, por ejemplo un enrutador de banda ancha o el servidor. - Asegúrese de que el reproductor y el servidor están conectados al mismo punto de acceso. - Configure correctamente el valor o valores de la red. Compruebe "Red". (pág. 32) - Dependiendo del servidor DLNA, es posible que sea necesario autorizar al reproductor desde el servidor.
No se puede reproducir el archivo en el servidor doméstico de red.	<ul style="list-style-type: none"> - Asegúrese de que el archivo se puede reproducir. (pág. 3) - Compruebe la configuración del servidor DLNA. - La calidad de funcionamiento y reproducción podría verse afectada por las condiciones de la red doméstica.

■ Mensajes en pantalla

- Los mensajes siguientes aparecerán en la pantalla del televisor si el disco que intenta reproducir no es apropiado o la operación no es correcta.

Mensaje de error	Causas posibles y soluciones
Not Support This File!	- El reproductor no admite el archivo. Consulte "Tipos de discos/archivos que se pueden utilizar con este reproductor" (pág. 3).
¡Código de región erróneo!	- El disco tiene un código de región incompatible. Consulte "Información de gestión de la región" (pág. 3).
La red ha fallado.	- El reproductor no se puede conectar a la red. Compruebe la conexión (pág. 16) y los valores de la red (pág. 32).
Red está bien, proxy ha fallado.	- El reproductor no se puede conectar al servidor proxy. Consulte "Configuración Proxy" (pág. 32).
The Setting is prohibited, please setup again.	- La conexión de BD-Live está prohibida. Consulte "Conexión BD-Live" (pág. 32).
¡No se encuentra un fichero válido para actualización!	- Compruebe si el archivo de actualización está en la carpeta apropiada.
¡La actualización ha fallado por alguna razón!	- La actualización ha fallado. Compruebe si el archivo de actualización está dañado o es ilegible.

AVCHD

AVCHD es un nuevo formato (estándar) para cámaras de vídeo de alta definición que se puede utilizar para grabar y reproducir imágenes de alta definición (HD).

BD-Live™

BD-Live es un estándar de BD que utiliza una conexión de red y permite al reproductor conectarse a la red para descargar vídeos promocionales y otros datos.

BDMV

BDMV (Blu-ray Disc Movie, BD-MV=Películas en disco Blu-ray BD-MV) se refiere a uno de los formatos de aplicación utilizados para BD-ROM que constituye una de las especificaciones de los discos Blu-ray. BDMV es un formato de grabación equivalente al Vídeo DVD de la especificación DVD.

Blu-ray 3D™

Blu-ray 3D le permite ver imágenes 3D de alta definición completa.

BONUSVIEW

Los discos compatibles con BONUSVIEW le permiten disfrutar simultáneamente de subcanal de vídeo para dos pantallas, subcanal de audio y subtítulos. Aparece una pequeña pantalla dentro de la pantalla principal durante la reproducción (Imagen en imagen).

Buzón (LB 4:3)

Un tamaño de pantalla con barras negras en las partes superior e inferior de la imagen para permitir la visualización de material en pantalla ancha (16:9) en un televisor 4:3 conectado.

Color Space

El Color Space es una gama de colores que se puede representar. RGB es un espacio de color basado en el modelo de color RGB (rojo, verde y azul) y se utiliza normalmente para monitores de PC. YCbCr es un espacio de color basado en una señal de luminancia (Y) y dos señales de diferencia de color (Cb y Cr).

Deep Color

Deep Color se refiere al uso de diversas profundidades de color en pantallas, a partir de las profundidades de 24 bits de versiones anteriores de la especificación HDMI. Esta profundidad de bits adicional permite que las pantallas HDTV y otros tipos de pantallas pasen de millones a miles de millones de colores y eliminan la aparición de bandas de color en pantallas permitiendo unas transiciones tonales suaves y una gradación ligera entre colores. La mayor relación de contraste permite representar muchos más tonos de gris entre blanco y negro. Además Deep Color aumenta el número de colores disponibles dentro de los límites definidos por el espacio de color RGB o YCbCr.

Dirección MAC

La dirección MAC es un valor único asignado a un dispositivo de red para fines identificativos.

DivX®

DivX® es una tecnología multimedia popular creada por DivX, Inc. Los archivos multimedia DivX® contienen vídeo muy comprimido con una alta calidad visual que mantiene un tamaño de archivo relativamente pequeño. Los archivos DivX® también pueden incluir características multimedia avanzadas como menús, subtítulos y pistas de audio alternativas. Muchos archivos multimedia DivX® están disponibles para descarga en línea y puede crear sus propios archivos utilizando su propio contenido y herramientas fáciles de utilizar de DivX.com.

Dolby Digital

Un sistema de sonido desarrollado por Dolby Laboratories Inc. que da un ambiente de sala de cine a la salida de audio cuando el producto está conectado con un amplificador o procesador Dolby Digital.

Dolby Digital Plus

Un sistema de sonido desarrollado como una extensión de Dolby Digital. Esta tecnología de codificación de audio soporta sonido envolvente de 7.1 multicanales.

Dolby TrueHD

Dolby TrueHD es una tecnología de codificación sin pérdidas que soporta hasta 8 canales de sonido envolvente multicanal para los discos ópticos de próxima generación. El sonido reproducido conserva fielmente, bit a bit, la fuente original.

DRC (Control de gama dinámica)

DRC le permite ajustar la gama entre los sonidos más alto y más bajo (gama dinámica) para reproducir a un volumen intermedio. Útilcelca cuando sea difícil escuchar los diálogos o durante las horas en que la reproducción pueda molestar a los vecinos.

DSD (Direct Stream Digital)

La tecnología DSD guarda señales de vídeo en soportes de almacenamiento digitales, como Super Audio CD. Mediante DSD, las señales se guardan como valores de un solo bit en frecuencias de muestreo altas, de 2,8224 MHz, mientras que el modelado del ruido y el sobremuestreo se utilizan para reducir la distorsión, un fenómeno habitual en situaciones de alta cuantificación de señales de audio. Debido a la elevada frecuencia de muestreo, es posible obtener una calidad de audio superior a la que ofrece el formato PCM utilizado para CD de audio normales.

DTS

Un sistema de sonido digital desarrollado por DTS, Inc. para su uso en salas de cine.

DTS-HD High Resolution Audio

DTS-HD High Resolution Audio es una nueva tecnología desarrollada para el formato de disco óptico de alta definición de próxima generación.

DTS-HD Master Audio

DTS-HD Master Audio es una tecnología de compresión de audio sin pérdidas desarrollada para el formato de disco óptico de alta definición de próxima generación.

DTS-HD Master Audio | Essential

DTS-HD Master Audio | Essential es una tecnología de compresión de audio sin pérdidas desarrollada para el formato de disco óptico de alta definición de próxima generación.

HDMI

HDMI (High-Definition Multimedia Interface, Interfaz Multimedia de Alta Definición) es una interfaz que soporta vídeo y audio en una sola conexión digital. La conexión HDMI lleva señales de vídeo, lo mismo estándar que de alta definición, y señales de audio en multicanal a componentes A/V, por ejemplo, televisores equipados con HDMI en forma digital y sin degradación.

Sonido PCM lineal

PCM lineal es un formato de grabación de señales utilizado para CD de audio y en algunos discos DVD y Blu-ray. El sonido de CD de audio se graba a 44,1 kHz con 16 bits. (El sonido se graba entre 48 kHz con 16 bits y 96 kHz con 24 bits en discos DVD y entre 48 kHz con 16 bits y 192 kHz con 24 bits en discos BD.)

Sincronismo de labios

Sincronismo de labios, una abreviatura de “lip synchronization”, o sincronización de labios, es un término que hace referencia tanto a un problema habitual como a la posibilidad de mantener sincronizadas las señales de audio y vídeo durante la posproducción y la transmisión. La latencia de audio y vídeo requiere complejos ajustes por parte del usuario, pero la versión 1.3 de HDMI incorpora una función de sincronización automática de audio y vídeo que permite a los dispositivos sincronizarse de forma automática y precisa y sin la intervención del usuario.

Panorámico (PS 4:3)

Un tamaño de pantalla que recorta los costados de la imagen para permitir la visualización de material de pantalla ancha (16:9) en un televisor 4:3 conectado.

Subtítulos

Son las líneas de texto que aparecen en la parte inferior de la pantalla y que traducen o transcriben el diálogo. Están grabadas en muchos discos de vídeo DVD y BD.

Subtítulos

La audiodescripción es un tipo de subtítulos, la diferencia entre los subtítulos y la audiodescripción es que los primeros están diseñados para personas sin problemas auditivos, mientras que los segundos lo están para personas que no oyen. Los subtítulos no suelen mostrar todo el audio. La audiodescripción muestra efectos de sonido (por ejemplo, un “suena el teléfono” y “ruido de pasos”), mientras que los subtítulos no lo hacen. Antes de seleccionar este ajuste, asegúrese de que el disco contiene información de audiodescripción.

Menú principal

En un Vídeo BD/Vídeo DVD es el menú para seleccionar elementos tales como el capítulo que se va a reproducir y el idioma de los subtítulos. En algunos vídeos DVD, al menú principal también se le denomina “Menú de títulos”.

x.v.Color

x.v.Color reproduce una gama de colores más amplia que antes, mostrando casi todos los colores que puede

ESPECIFICACIONES

Generalidades

Alimentación

[Modelos de EE. UU. y Canadá].....	110-240 V CA, 60 Hz
[Modelos para América Central y del Sur].....	110 – 240 V CA, 50/60 Hz
[Modelos para Europa y Rusia]	CA 230 V, 50 Hz
[Modelo para Australia]	110-240 V CA, 50 Hz
[Modelo para Asia]	CA 220 – 240 V, 50/60 Hz
[Modelo para Taiwán].....	CA 110 – 120 V, 50/60 Hz
[Modelo para Corea]	CA 220 V, 60 Hz
Consumo de energía (normal)	25 W
Consumo (en espera)	0,5 W o menos
Dimensiones (Ancho x Alto x Largo)	435 x 96 x 316 mm
Peso	4,05 kg

Rendimiento de audio

Nivel de salida de audio (1 kHz, 0 dB, BD/DVD/CD-DA)	2 ± 0,3 V
Relación señal/ruido (BD/DVD/CD-DA)	115 dB o más
Rango dinámico	
BD/DVD	105 dB o más
CD-DA	100 dB o más
Distorsión armónica (1 kHz)	
BD/DVD	0,0028% o menos
CD-DA	0,003 % o menos
Respuesta de frecuencia	
BD/DVD	2 Hz a 22 kHz (muestreo a 48 kHz)
	2 Hz a 44 kHz (muestreo a 96 kHz)
CD-DA	2 Hz a 20 kHz

Entrada/salida

Salida HDMI	Conector tipo A x 1
	480i/576i/480p/576p/720p/1080i/1080p/1080p@24Hz,
	Soporte Deep Color, x.v. Color
Salida de vídeo componente.....	Y: 1 Vp-p (75 ohmios)
	Pb, Pr: 0,7 Vp-p (75 ohmios)
Salida de vídeo	1 Vp-p (75 ohmios)
Salida digital.....	Óptica x 1, Coaxial x 1
Salida de audio analógica.....	7.1 canales x 1
	Mixed 2 canales x 1
Conectores USB	Tipo A x 2
Otros equipos	Remote IN/OUT x 1
	RS-232C x 1 (instalación personalizada),
	Ethernet x 1

Las especificaciones están sujetas a cambio sin previo aviso.

■ Propiedad intelectual

- El material audio-visual puede consistir de productos con propiedad intelectual que no se deben grabar sin la autorización del poseedor de dicha propiedad intelectual. Remítase a las leyes aplicables en su país.
- Este producto contiene tecnología de protección de copia que está protegida por patentes de los EE. UU. y otros derechos de propiedad intelectual de Rovi Corporation. Se prohíbe la ingeniería inversa o el desarmado de la unidad.
- Fabricado bajo licencia de Dolby Laboratories. Dolby y el símbolo de la doble D son marcas comerciales de Dolby Laboratories.
- Fabricado con licencia bajo las patentes de EE.UU. número: 5,451,942; 5,956,674; 5,974,380; 5,978,762; 6,226,616; 6,487,535; 7,212,872; 7,333,929; 7,392,195; 7,272,567 y otras patentes de los EE.UU. e internacionales emitidas o pendientes. DTS y el símbolo son marcas registradas y los logotipos DTS-HD, DTS-HD Master Audio y DTS son marcas comerciales de DTS, Inc.. El producto comprende también el software. © DTS, Inc. Todos los derechos reservados.
- “Blu-ray Disc™”, “Blu-ray™”, “Blu-ray 3D™”, “BD-Live™”, “BONUSVIEW™” y los logotipos son marcas comerciales de Blu-ray Disc Association.
- **DVD** es una marca comercial de DVD Format/Logo Licensing Corporation.
- HDMI, el logotipo HDMI y High-Definition Multimedia Interface son marcas comerciales o marcas registradas de HDMI Licensing LLC.
- “x.v.Color” y el logotipo “x.v.Color” son marcas comerciales.
- “AVCHD” y el logotipo “AVCHD” son marcas comerciales de Panasonic Corporation y Sony Corporation.
- Java y todas las marcas comerciales y logotipos basados en Java son marcas comerciales o marcas registradas de Sun Microsystems, Inc. en los Estados Unidos y/o otros países.
- Este producto se otorga con licencia bajo la licencia de cartera de patentes AVC y la licencia de cartera de patentes VC-1 para su uso personal y no comercial por parte de un consumidor para (i) codificar vídeo que cumpla con las normas AVC y VC-1 (“AVC/VC-1 Video”) y/o (ii) descodificar vídeo AVC/VC-1 codificado por un consumidor dedicado a una actividad personal y no comercial y/o que se obtuvo de un proveedor de vídeo con licencia para proporcionar vídeo AVC/VC-1. No se otorga o se da por supuesta licencia alguna para cualquier otro uso. Se puede obtener información adicional de MPEG LA, LLC.
Consulte <http://www.mpegla.com>.
- Windows Media Player es una marca comercial o una marca comercial registrada de Microsoft Corporation en Estados Unidos y/o en otros países.
- DLNA y DLNA CERTIFIED son marcas comerciales y/o marcas de servicio de Digital Living Network Alliance.
- YouTube y el logotipo YouTube son marcas comerciales de Google, Inc.

- “DivX®, DivX Certified®, DivX Plus™ HD y los logotipos asociados son marcas comerciales registradas de DivX, Inc. y se utilizan con licencia.”
- “DivX Certified® para reproducir vídeo DivX® y DivX Plus™ HD (H.264/MKV) hasta 1080p HD y contenido de calidad.”

ABOUT DIVX VIDEO: DivX® es un formato de vídeo digital creado por DivX, Inc. Este equipo es un dispositivo DivX Certified® oficial que reproduce vídeo DivX. Visite divx.com para obtener más información y conseguir herramientas de software para convertir sus archivos a vídeo DivX.

ABOUT DIVX VIDEO-ON-DEMAND: este dispositivo DivX Certified® debe registrarse para poder reproducir películas DivX Video-on-Demand (VOD) compradas. Para obtener el código de registro, busque el apartado DivX VOD en el menú de configuración del dispositivo. Visite el sitio vod.divx.com para obtener más información sobre el proceso de registro.

주의: 본 기기를 조작하기 전에 읽어 주십시오.

- 1 최고의 성능을 위하여 본 설명서를 주의깊게 읽어 보십시오. 본 설명서를 안전한 곳에 보관하고 나중에 참고하십시오.
- 2 서늘하고 건조하며 통풍이 잘 되는 청결한 곳에 본 기기를 설치하고, 직사광선, 발열기구, 진동, 먼지, 습기를 멀리하고 추운 곳에 두지 마십시오. 환기가 잘 되게 하려면 아래와 같이 여유를 두십시오.
위쪽: 10 cm
뒤쪽: 10 cm
옆쪽: 10 cm
- 3 뒤편거리는 소리를 방지하려면 다른 전자 제품, 모터 또는 변압기에서 본 기기를 멀리 떨어뜨려 설치하십시오.
- 4 본 기기 내부의 결로 현상을 방지하려면 낮은 온도에서 높은 온도로 온도가 급격하게 변하는 곳에 본 기기를 노출시키거나 습도가 높은 환경 (예, 가습기가 있는 욕)에 본 기기를 설치하지 마십시오. 화재가 발생하거나, 기기가 손상되거나, 사용자가 감전되거나 부상당할 수도 있습니다.
- 5 이물질이 본 기기에 떨어질 수 있는 곳, 또는 액체가 떨어지거나 흐를 수 있는 곳에 본 기기를 설치하지 마십시오. 본 기기위에 다음과 같은 물체를 올려놓지 마십시오:
 - 다른 기기. 본 기기의 표면이 손상되거나 변색될 수도 있습니다.
 - 연소되는 물체 (예, 초). 화재가 발생하거나 본 기기가 손상되거나 사용자가 부상당할 수도 있습니다.
 - 액체가 담긴 용기. 용기가 넘어져 사용자가 감전되거나 본 기기가 손상될 수도 있습니다.
- 6 열 복사가 방해되지 않도록 신문, 책상보 및 커튼 등으로 본 기기를 덮지 마십시오. 본 기기의 내부 온도가 높아지면 화재가 발생하거나 본 기기가 손상되거나 사용자가 부상당할 수도 있습니다.
- 7 모든 연결이 완료될 때까지 본 기기의 플러그를 연결하지 마십시오.
- 8 본 기기를 뒤집어서 조작하지 마십시오. 본 기기가 과열되어 손상될 수도 있습니다.
- 9 스위치, 노브 또는 코드에 강한 압력을 가하지 마십시오.
- 10 전원 케이블을 콘센트에서 분리하는 경우, 항상 플러그를 잡고 케이블을 잡아 당기지 마십시오.
- 11 화학 솔벤트로 본 기기를 닦지 마십시오. 표면의 마무리가 훼손될 수도 있습니다. 깨끗하고 마른 헝겊을 사용하십시오.
- 12 반드시 본 기기에 지정된 전압만을 사용하십시오. 지정된 전압 이외의 전압을 사용하는 것은 매우 위험하며 화재가 발생하거나 본 기기가 손상되거나 사용자가 부상당할 수도 있습니다. 지정된 전압 이외의 전압을 사용하여 발생한 손상에 대해서 Yamaha는 어떠한 책임도 지지 않습니다.
- 13 번개에 의한 손상을 방지하려면 뇌우시 전원 케이블을 콘센트에서 분리하십시오.
- 14 본 기기를 개조하거나 수리하지 마십시오. 서비스가 필요한 때에는 공인 Yamaha 정비사에게 의뢰하십시오. 어떤 이유로든지 절대로 캐비닛을 열지 마십시오.
- 15 오랜 기간 동안 본 기기를 사용하지 않는 경우 (예, 휴가), 전원을 콘센트에서 분리하십시오.
- 16 본 기기의 고장을 결정하기 전에 일반 조작 예러의 "문제 해결" 장을 반드시 읽어 보십시오.

- 17 본 기기를 옮기기 전에 를 눌러 본 기기를 대기 모드로 설정하고 AC 전원 플러그를 콘센트에서 분리하십시오.
- 18 주변 온도가 급격히 변하는 경우, 결로 현상이 발생합니다. 전원 케이블을 콘센트에서 분리한 후 본 기기를 둡니다.
- 19 본 기기를 장시간 사용하는 경우, 기기가 과열될 수도 있습니다. 전원을 끄고 식도록 본 기기를 둡니다.
- 20 기기를 설치할 때 벽면 콘센트에 쉽게 접근할 수 있도록 하여 주십시오.
- 21 천전지를 직사광선, 불꽃 등과 같이 과도한 화기에 노출시키지 마십시오.

본 기기가 콘센트에 연결되어 있으면 으로 본 기기의 자체 전원을 끄더라도 전원이 차단되지 않습니다. 이를 대기 모드로 합니다. 이 상태에서 본 기기는 아주 적은 양의 전원을 소모하도록 설계되어 있습니다.

경고

화재 및 감전의 위험을 줄이기 위해 본체를 비나 습기 등에 노출시키지 마십시오.

본 제품의 레이저 부품은 클래스 1에 제한을 초과하는 방사능을 방사합니다.

주의

여기서 지정한 이외의, 조정이나 제어 또는 동작을 실시했을 경우, 유해한 방사선에 노출될 위험이 있습니다.

레이저 사양

Class 1 레이저 제품
파장: 790 nm (CD)/655 nm (DVD)/405 nm (BD)
레이저 출력: 최대 1 mW

레이저 안전

본 기기는 레이저를 사용하고 있습니다. 시력이 손상될 수 있으므로 공인 서비스 기술자만 커버를 열고 본 기기를 수리해야 합니다.

위험

본 기기를 열면 가시 레이저 방사선이 방출됩니다. 유안으로 빔을 직접 보지 마십시오. 본 기기 플러그가 콘센트에 연결된 경우, 디스크 트레이의 입구나 다른 개구부 또는 내부에 눈을 가깝게 대지 마십시오.

목차

1

1. 소개

본 플레이어에서 할 수 있는 작업	2
부속품	2
디스크 및 파일에 대하여	3
본 플레이어에서 사용할 수 있는 디스크/파일 유형	3
디스크 넣기	4
디스크 주의사항	4
각 부 명칭 및 기능	5
앞면 패널	5
리모콘	6

2. 연결

연결 방법	10
뒷면 패널	10
HDMI 연결	12
HDMI 단자에 연결	12
Blu-ray 3D 디스크 재생을 위한 연결	12
비디오 연결	13
컴포넌트/비디오 잭에 연결	13
오디오 연결	14
디지털 오디오 잭/단자에 연결	14
오디오 잭에 연결	15
네트워크 및 USB 연결	16
NETWORK 단자 및 USB 포트에 연결	16
기타 연결	17
REMOTE CONTROL 잭에 연결	17
전원 케이블 연결	17

3. 재생

INITIAL WIZARD/EASY SETUP	18
Initial Wizard/Easy Setup을 사용하여 설정	18
HOME/MEDIA 메뉴	19
사진/음악/비디오 재생	19
네트워크 콘텐츠 사용	21
네트워크 서비스 사용	22
YouTube™에서 비디오 재생	22
고급 재생 조작	23
On Screen 메뉴	23
상태 메뉴	24
Bookmark 사용	25
프로그램 재생	25
검색 사용	25
BONUSVIEW™ 및 BD-Live™ 즐기기	26
Picture in Picture 기능 사용 (보조 오디오/비디오 재생)	26
BD-Live™ 기능 사용	26

4. 설정

SETUP 메뉴	27
SETUP 메뉴 조작 예	29
General Setting	30
Display Setting	32
Audio Setting	34
System Information	34
오디오 출력 형식에 대하여	35
비디오 출력 형식에 대하여	36
소프트웨어 업그레이드	37
소프트웨어 업그레이드	37

5. 추가 정보

문제 해결	38
전원	38
기본 조작	38
디스크 재생	38
사진	39
사운드	39
네트워크	40
화면의 메시지	40
용어집	41
제품 사양	42
일반 사양	42
오디오 성능	42
입력/출력	42
저작권	43

(본 설명서 끝)

Information about software	i
----------------------------	---

2

3

4

5

■ 본 사용 설명서에 대하여

- 본 설명서는 리모콘을 사용할 수 있는 경우 리모콘으로 본 플레이어를 조작하는 방법에 대해 설명합니다. 일부 조작은 앞면 패널 버튼을 사용하여 수행 수도 있습니다.
- 참고에는 안전 및 조작 방법에 대한 중요한 정보가 들어 있습니다. 힌트는 조작을 위한 팁입니다.
- 본 설명서는 제품이 생산되기 전에 인쇄됩니다. 제품 향상 등에 따라 디자인과 제품 사양이 변경될 수 있습니다. 설명서와 제품 간에 차이가 있는 경우에는 제품을 우선시 합니다.

본 설명서에 사용된 아이콘

아이콘은 특정 형식에서 사용 가능한 버튼/기능을 나타내기 위해 사용됩니다.

- BD** : BD-Video
- DVD** : DVD-Video, DVD-VR, DVD+ VR, DVD-Audio
- CD** : 오디오 CD, Super Audio CD
- VIDEO** : AVCHD, WMV, DivX
- MUSIC** : MP3, WMA, WAV
- PHOTO** : JPEG

한국어

본 플레이어에서 할 수 있는 작업

언어, 해상도, 화면비율 간편 설정

→ 18페이지

언어 및 TV 설정을 할 수 있습니다.

상업용으로 발매된 Blu-ray™/DVD/CD/SA-CD/DVD-Audio 디스크 재생*

→ 23페이지

본 플레이어에서는 Blu-ray Discs™(BD 디스크) 이외에 다양한 다른 디스크의 재생도 지원됩니다.

BONUSVIEW™, BD-Live™ 등 재생*

→ 26페이지

최신 BD 디스크에서 동영상을 즐길 수 있습니다.

디스크에서 비디오, 음악, 사진 파일 재생*

→ 19페이지

녹화된 디스크를 본 플레이어에서 재생할 수 있습니다.

디스크/USB 메모리 장치에서 비디오, 음악, 사진 파일 재생*

→ 19페이지

디스크/USB 메모리 장치에 녹화된 파일을 본 플레이어에서 재생할 수 있습니다.

홈 네트워크 서버에서 비디오, 음악, 사진 파일 재생* **

→ 21페이지

본 플레이어를 네트워크 서버에 연결하면 TV 또는 AV 리시버에서 PC 콘텐츠를 재생할 수 있습니다.

리모콘으로 TV, AV 리시버 등 조작

→ 30페이지

HDMI 케이블을 사용하여 장치를 연결하면 HDMI Control 기능을 사용하여 리모콘 하나로 여러 장치를 조작할 수 있습니다.

네트워크 서비스 상의 스트리밍 재생 콘텐츠**

→ 22페이지

본 플레이어를 이용하여 인터넷을 통해 즉시 비디오를 즐길 수 있습니다.

* 재생 가능한 디스크 및 형식에 대한 자세한 내용은 3페이지를 참조하십시오.

** 이 기능을 사용하려면 네트워크 설정이 필요합니다.

부속품

제품에 다음과 같은 액세서리가 제공되었는지 확인하십시오.

리모콘



배터리(x2)
(AAA, R03, UM-4)

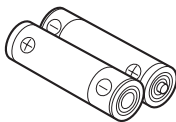

오디오 핀 케이블

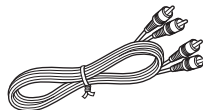

비디오 핀 케이블

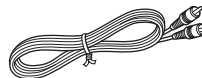

전원 케이블

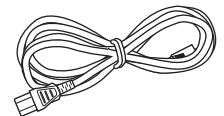









디스크 및 파일에 대하여

■ 본 플레이어에서 사용할 수 있는 디스크/파일 유형

- 본 플레이어에서는 12 cm 및 8 cm 디스크를 재생할 수 있습니다. 8 cm를 12 cm 어댑터를 사용하지 마십시오.
- 호환 표준을 준수하는 디스크에 한하여 디스크 라벨에 공식 로고가 표시되어 있습니다. 호환 표준을 준수하는 디스크를 사용하십시오. 이 표준을 따르지 않는 디스크의 재생은 보장되지 않습니다. 디스크가 재생되더라도 화질 또는 음질은 보장되지 않습니다.





디스크 유형	녹화 형식	데이터 형식
BD-ROM/BD-R/BD-RE	BD-Video	--
DVD-ROM	DVD-Video/DVD-Audio	--
DVD-R/DVD-R DL/DVD-RW	DVD-Video/DVD-VR/AVCHD/데이터 디스크	DivX/WMV/MP3/WAV/WMA/JPEG
DVD+R/DVD+R DL/DVD+RW	DVD-Video/DVD+VR/AVCHD/데이터 디스크	DivX/WMV/MP3/WAV/WMA/JPEG
CD-ROM	CDDA/HDCD	--
CD-R/CD-RW	CDDA/데이터 디스크	DivX/WMV/MP3/WAV/WMA/JPEG
SA-CD	SA-CD	--
USB	--	DivX/WMV/MP3/WAV/WMA/JPEG
네트워크	--	WMV/MP3/WMA/WAV/JPEG

지역 관리 정보		
지역	BD-Video	DVD-Video
중남미	지역 코드 "A" 또는 "ALL" 	지역 번호 "4" 또는 "ALL" 
유럽	지역 코드 "B" 또는 "ALL" 	지역 번호 "2" 또는 "ALL" 
호주	지역 코드 "B" 또는 "ALL" 	지역 코드 "4" 또는 "ALL" 
러시아	지역 코드 "C" 또는 "ALL" 	지역 번호 "5" 또는 "ALL" 

- BD/DVD Video 플레이어 및 디스크에는 디스크를 재생할 수 있는 지역을 나타내는 지역 코드가 있습니다.
- BD/DVD Video 조작 및 기능은 본 설명서의 설명과 다를 수 있으며, 디스크 제조업체의 설정에 따라 일부 조작이 제한될 수 있습니다.
- 디스크 재생 도중 메뉴 화면 또는 조작 지침이 표시되는 경우 표시된 절차를 따르십시오.

참고

- 디스크에 따라 왼쪽 표의 디스크 중 일부가 재생되지 않을 수 있습니다.
- 본 플레이어에서 재생되는 모든 녹화 미디어를 파이널라이즈하십시오.
- "파이널라이즈"는 녹화된 디스크가 본 플레이어는 물론 다른 플레이어/레코더에서도 재생되도록 레코더에서 진행되는 처리 작업입니다. 본 플레이어에서는 파이널라이즈된 디스크만 재생됩니다. (본 플레이어에는 디스크를 파이널라이즈하는 기능이 없습니다.)
- 디스크, USB 메모리 장치 및 네트워크에서 일부 파일의 재생은 보장되지 않습니다.
- 저작권 보호 파일은 USB 메모리 장치 및 네트워크를 통해 재생할 수 없습니다.

지역 관리 정보		
지역	BD-Video	DVD-Video
미국 및 캐나다	지역 코드 "A" 또는 "ALL" 	지역 코드 "1" 또는 "ALL" 
아시아	지역 코드 "A" 또는 "ALL" 	지역 번호 "3" 또는 "ALL" 
대만	지역 코드 "A" 또는 "ALL" 	지역 번호 "3" 또는 "ALL" 
한국	지역 코드 "A" 또는 "ALL" 	지역 번호 "3" 또는 "ALL" 

MP3/WMA/WAV 오디오 파일 요구사항

- 샘플링 주파수: 32 - 48 kHz(MP3/WMA), LPCM 44.1 kHz/16 비트/스테레오(WAV)
- 비트 전송률: 8 - 320 kbps(MP3) 이내, 32 - 192 kbps(WMA)

WMV 파일 요구사항

- WMV9, 최대 해상도는 1,920 × 1,080입니다.

Super Audio CD(SA-CD)에 대하여

- 이 오디오 형식은 현재의 CD 표준을 기반으로 하지만 더 많은 양의 고음질 정보를 포함하고 있습니다. 디스크에는 단층, 이중, 하이브리드의 3종류가 있습니다. 하이브리드 디스크는 표준 오디오 CD 및 Super Audio CD 정보가 모두 포함되어 있어서 기존 CD 플레이어 및 Super Audio CD 플레이어에서도 재생할 수 있습니다.

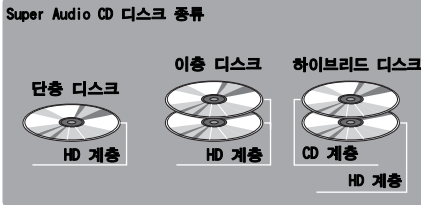

힌트

- 호환되는 AV 리시버를 사용하면 본 플레이어에서 HDMI를 통한 DSD 데이터 전송이 지원됩니다.

참고

- 본 기기의 표시창에는 디스크에 들어 있는 텍스트 데이터가 표시되지 않습니다.

■ 디스크 넣기

- 라벨이 위로 오도록 디스크를 넣으십시오.
- 양면 녹화된 디스크의 경우, 재생할 면이 아래로 가도록 넣으십시오.

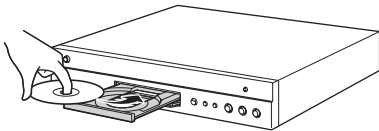

참고

- 디스크 및 본 플레이어의 설정에 따라 재생이 자동으로 시작될 수 있습니다.
- 디스크에 따라 메뉴가 먼저 표시될 수 있습니다.
- 디스크에 따라 디스크를 읽어들이는 시간이 다를 수 있습니다.

■ 디스크 주의사항

긁힘 및 먼지 주의

- BD, DVD 및 CD 디스크는 먼지, 지문 및 특히 스크래치에 취약합니다. 스크래치가 있는 디스크는 재생되지 않을 수 있습니다. 디스크를 조심해서 다루고 안전한 장소에 보관하십시오.

적절한 디스크 보관

디스크를 디스크 케이스의 가운데에 넣고 케이스와 디스크를 똑바로 세워 보관하십시오.	
직사광선에 노출된 곳, 난방 기기 근처 또는 습도가 높은 장소에 디스크를 보관하지 마십시오.	
디스크를 떨어뜨리거나 강한 진동이나 충격을 가하지 마십시오.	
먼지 또는 습기가 많은 장소에 디스크를 보관하지 마십시오.	

취급 시 주의 사항



- 표면이 더러워진 경우 물에 살짝 적신 부드러운 헝겊으로 살살 닦으십시오. 디스크를 닦을 때에는 항상 가운데 구멍에서 바깥쪽으로 닦으십시오.



- 레코딩용 클리닝 스프레이, 벤젠, 시너, 정전기 방지 용액 또는 기타 용해제를 사용하지 마십시오.

- 표면을 만지지 마십시오.
- 디스크에 종이 또는 접착 라벨을 붙이지 마십시오.
- 디스크의 재생 면이 더러워지거나 긁힘 경우 플레이어가 호환되지 않는 디스크로 판단하여 디스크 트레이가 열리거나, 디스크를 올바르게 재생하지 못할 수 있습니다. 부드러운 헝겊으로 재생 면의 먼지를 닦아 주십시오.

픽업 렌즈 청소

- 시판용 클리닝 디스크는 절대 사용하지 마십시오. 렌즈가 손상될 수 있습니다.
- 렌즈를 청소하려면 가까운 공인 Yamaha 서비스 센터에 요청하십시오.

■ 앞면 패널

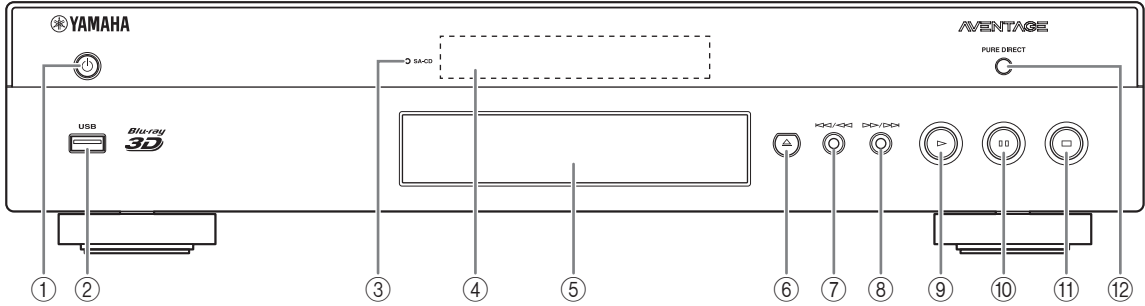

- ① **⏻ (켄/대기)**
- ② **USB 포트(16페이지)**
- ③ **SA-CD 표시등:** SA-CD를 넣고 SA-CD 계층(4페이지)을 선택하면 점등됩니다.
- ④ **표시창**
- ⑤ **디스크 트레이(4페이지)**
- ⑥ **▲ (꺼냄):** 디스크 트레이를 열거나 닫습니다.
- ⑦ **⏮/⏪ (뒤로 검색/뒤로 건너뛰기):** 버튼을 누르면 뒤로 건너뛰고, 버튼을 누르고 있으면 뒤로 검색합니다.
- ⑧ **▶▶/▶ (앞으로 검색/앞으로 건너뛰기):** 버튼을 누르면 앞으로 건너뛰고, 버튼을 누르고 있으면 앞으로 검색합니다.
- ⑨ **▶ (재생)**
- ⑩ **■ (일시 정지)**
- ⑪ **■ (정지)**
- ⑫ **PURE DIRECT:** Pure Direct 모드(7페이지)가 모드 1/모드 2/Off로 변경됩니다. Pure Direct 모드가 모드 1/모드 2로 설정된 경우 버튼이 점등됩니다.

리모콘에 배터리 넣기

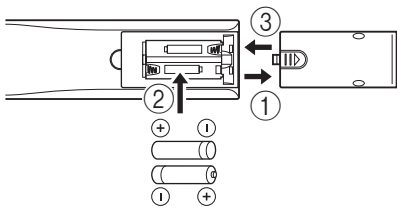

참고

- 리모콘에 충격을 가하거나 물이나 습기가 심한 곳에 놓아두지 마십시오.
- 플레이어의 리모콘 센서가 직사광선 또는 다른 강한 빛에 노출된 경우 리모콘이 작동하지 않을 수 있습니다.
- 배터리를 잘못 사용하면 누액되거나 과열될 수 있습니다. 배터리 경고를 읽고 배터리를 올바르게 사용하십시오.
- 쓰던 배터리와 새 배터리를 혼용하거나 브랜드가 다른 배터리를 혼용하지 마십시오.
- 리모콘을 장기간 사용하지 않을 경우 배터리를 꺼내놓으십시오.
- 해당 지역의 규정에 따라 배터리를 폐기하십시오.

대략적인 리모콘 작동 범위

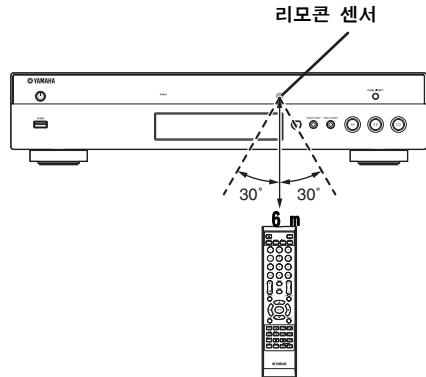



리모콘

참고

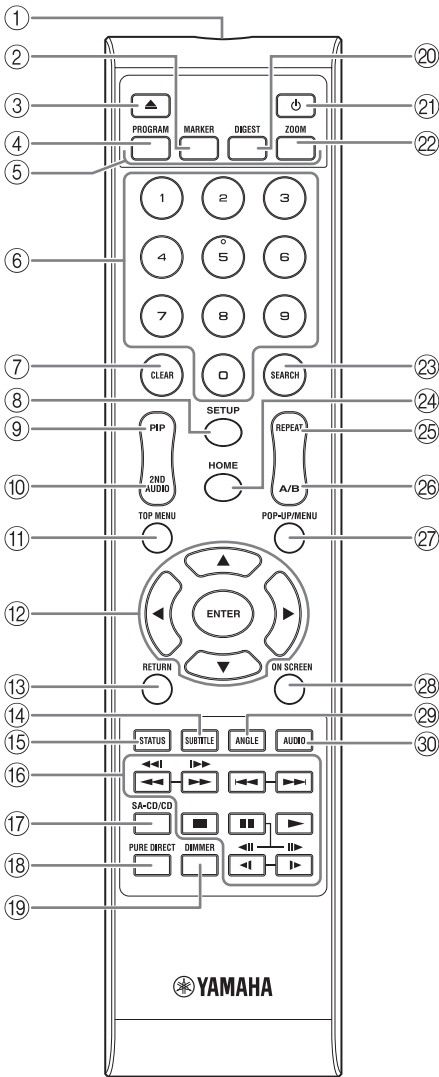
- 사용할 수 없는 버튼을 누르면 가 화면의 왼쪽 상단에 나타납니다.



- ① **적외선 신호 송신기**: 적외선 신호가 나옵니다. 이 창을 리모콘 센서 쪽으로 향하게 합니다(5페이지).
- ② **MARKER**  **VIDEO**: 동영상에서 지정한 지점에 Bookmark(25페이지)를 설정합니다. Bookmark를 설정한 다음 이동하려는 지점을 선택하려면 **DIGEST**를 누릅니다. 북마크를 12개까지 설정할 수 있습니다.
- ③ **▲**: 디스크 트레이를 열거나 닫습니다.
- ④ **PROGRAM**  **CD**: 재생 순서(25페이지)를 설정합니다. 최대 15개의 트랙(오디오 디스크의 경우) 또는 타이틀/챕터(DVD-Video)를 설정할 수 있습니다.
- ⑤ **색상 버튼** **BD**: 화면 지점에 따라 이 버튼을 사용합니다.
- ⑥ **숫자 버튼**: 숫자를 입력하거나, 재생 도중 입력한 숫자에 해당하는 트랙/챕터로 이동합니다. 디스크 종류 및 재생 조건에 따라 이 버튼을 사용하지 못할 수 있습니다.
- ⑦ **CLEAR**: 입력한 숫자/설정 항목을 지웁니다.
- ⑧ **SETUP**: SETUP 메뉴 화면(27페이지)을 표시합니다.
- ⑨ **PIP** **BD**: Picture in Picture(26페이지)를 설정/해제합니다. 이 기능을 사용할 수 있으면 PIP Mark ()가 화면에 표시됩니다. On Screen 메뉴(23페이지)에서 이 항목을 선택할 수도 있습니다.

참고

- PIP Mark가 On으로 설정된 경우에만 PIP Mark가 표시됩니다(31페이지).
- ⑩ **2ND AUDIO** **BD**: Picture in Picture(26페이지) 또는 오디오 방송의 보조 오디오를 선택합니다. 이 기능을 사용할 수 있으면 Secondary Audio Mark ()가 화면에 표시됩니다(34페이지). On Screen 메뉴(23페이지)에서 이 항목을 선택할 수도 있습니다.

참고

- Secondary Audio Mark가 On으로 설정된 경우에만 Secondary Audio Mark가 표시됩니다(31페이지).

- ⑪ **TOP MENU** **BD** **DVD** : 디스크에 메뉴가 포함된 경우 맨 처음 메뉴 화면(42페이지)이 표시됩니다. ▲/▼/◀/▶ 및 **ENTER**를 사용하여 원하는 항목을 선택합니다.

참고

- 디스크에 따라 특정 조작이 다를 수 있습니다. 각 메뉴 화면의 지침을 따르십시오.

- ⑫ **커서 버튼(▲/▼/◀/▶)**: 메뉴 화면에서 초점을 이동합니다.
ENTER: 초점을 맞춘 메뉴/항목을 선택합니다.
- ⑬ **RETURN**: 이전 메뉴 또는 화면 등으로 돌아갑니다.
- ⑭ **SUBTITLE** **BD** **DVD** **VIDEO** : 사용 가능한 경우 자막 언어(42페이지)를 변경합니다. On Screen 메뉴 (23페이지)에서 이 항목을 선택할 수도 있습니다.
- ⑮ **STATUS**: 재생 정보(24페이지)를 표시합니다.

⑯ **조절 버튼**

BD **DVD** **CD** **VIDEO** **MUSIC** **PHOTO**

◀◀/▶▶

BD **DVD** **CD** **VIDEO** **MUSIC** :

앞으로/뒤로 검색합니다. 버튼을 누를 때마다 검색 속도가 변경됩니다(앞/뒤로 검색: 각각 5단계).

▶를 누르면 일반 재생이 다시 시작됩니다.

PHOTO : 슬라이드 쇼의 속도를 변경합니다. (느리게/빠르게: 3단계)

◀◀/▶▶ **BD** **DVD** **CD** **VIDEO** **MUSIC** :

버튼을 누르고 있으면 즉시 검색/다시 보기를 합니다. 즉시 검색은 콘텐츠를 30초 건너뛸니다. 즉시 다시 보기는 콘텐츠를 10초 전부터 다시 봅니다.

◀◀/▶▶: 앞/뒤로 건너뛸니다.

■: 재생을 정지합니다. 재생을 완전히 중지하려면 이 버튼을 두 번 누릅니다.

■: 재생을 일시 정지합니다.

▶: 콘텐츠를 재생합니다.

◀(◀◀)/▶(▶▶)

BD **DVD** : 느리게 앞/뒤로 이동합니다. 버튼을 누를 때마다 저속 재생 속도가 변경됩니다(느리게 앞/뒤로 이동: 각각 4단계).

일시 정지 도중 이 버튼을 누르면 프레임 순방향/역방향 재생을 수행합니다.

▶를 누르면 일반 재생이 다시 시작됩니다.

대부분 DVD-Audio 디스크에는 슬라이드 쇼 및 페이지 넘김 기능이 포함되어 있습니다. ◀/▶를 누르면 이전/다음 페이지로 이동합니다. 이 기능은 DVD-Audio에만 해당됩니다.

참고

- 일부 BD/DVD 디스크에서는 프레임 순방향/역방향 재생 기능이 호환되지 않습니다.

- 본 플레이어는 디스크에 따라 플레이어가 이전에 정지된 지점부터 재생이 다시 시작됩니다. 처음부터 재생하려면 ■를 두 번 누른 다음 ▶를 누르십시오.

- ⑰ **SA-CD/CD**: 하이브리드 SA-CD의 재생 계층을 SA-CD 및 CD 중에서 전환합니다(4페이지).

힌트

- SA-CD를 넣고 SA-CD 계층을 선택하면 앞면 패널의 SA-CD/CD 표시등(5페이지)이 점등됩니다(34페이지).

참고

- SA-CD 계층을 선택한 경우 오디오 신호는 AUDIO OUT 잭(11페이지)에서만 출력됩니다.

- DSD 멀티 채널 형식으로 녹음된 오디오 신호는 본 플레이어에서 재생되지 않습니다.

- ⑱ **PURE DIRECT**: Pure Direct 모드를 변경합니다. 버튼을 누를 때마다 아래 표시된 Pure Direct 모드가 변경됩니다. Pure Direct 모드를 사용하면 음질이 향상됩니다. 앞면 패널의 PURE DIRECT는 Pure Direct 모드가 모드 1/모드 2로 설정된 경우 점등됩니다.

모드 1: 표시창이 꺼지고, 비디오 신호가 출력되지 않습니다. 이 모드는 오디오 청취 시 적합합니다.

모드 2: 표시창이 꺼지고, HDMI 단자 이외에서 출력되는 비디오 신호가 출력되지 않습니다. 이 모드는 고음질의 동영상 시청 시 적합합니다.

Off: 일반 재생.

- ⑲ **DIMMER**: 표시창의 밝기가 5단계로 변경됩니다.
- ⑳ **DIGEST** **PHOTO** : 12개의 사진 썸네일을 표시합니다. 썸네일이 표시되면 ◀◀/▶▶를 사용하여 다음/이전 페이지로 이동할 수 있습니다.
DVD **VIDEO** : Bookmark 선택 막대를 표시합니다(25페이지).
- ㉑ **⏻**: 본 플레이어를 켜거나 대기 모드로 설정합니다.
- ㉒ **ZOOM** **DVD** **VIDEO** **PHOTO** : 확대/축소합니다. 버튼을 누를 때마다 화면 크기가 변경됩니다(확대/축소: 각각 3단계).

다음 페이지에 계속. →

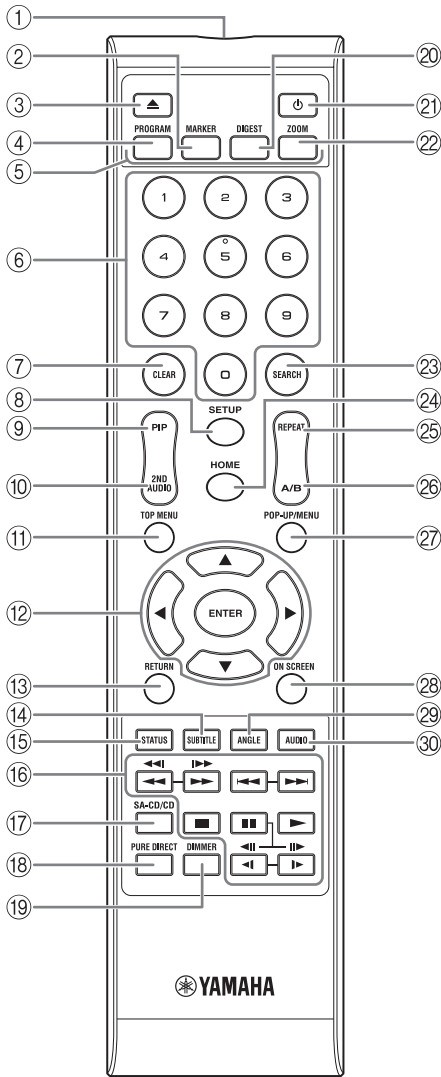

⑳ **SEARCH** **BD** **DVD** **CD** **VIDEO** **MUSIC** : 재생 도중 지정한 지점으로 이동합니다. 이 기능에 대한 자세한 내용은 "검색 사용"(25페이지)을 참조하십시오. 상태 메뉴(24페이지)에서 이 항목을 선택할 수도 있습니다.

㉑ **HOME** : HOME 메뉴 화면(19페이지)을 표시합니다.

㉒ **REPEAT** **BD** **DVD** **CD** **VIDEO** **MUSIC**
PHOTO : 반복 모드를 변경합니다. 버튼을 누를 때마다 아래 표시된 반복 모드가 변경됩니다.

: 재생 중인 타이틀을 반복합니다.

: 재생 중인 챕터를 반복합니다.

: 재생 중인 폴더를 반복합니다.

: 디스크의 모든 트랙/파일을 반복합니다.

: 재생 중인 트랙/파일을 반복합니다.

㉓ **A/B** **BD** **DVD** **CD** **VIDEO** **MUSIC** : 반복하려는 특정 부분을 재생합니다.

1 시작 지점으로 설정하려는 장면에서 **A/B**를 누릅니다. "A-"가 화면에 표시됩니다.

2 끝 지점으로 설정하려는 장면에서 **A/B**를 다시 누릅니다. "A-B"가 화면에 표시됩니다. 반복 재생이 시작됩니다.

3 반복 재생을 취소하려면 **A/B**를 누릅니다. "A-B"가 사라지고 반복 재생이 종료됩니다.

참고

- 디스크의 사양에 따라 이 기능을 수행하지 못할 수 있습니다.

㉔ **POP-UP/MENU** **BD** **DVD** : 팝업 메뉴를 표시합니다. 표시되는 메뉴 내용은 디스크에 따라 다릅니다. 팝업 메뉴의 표시 및 조작 방법에 대한 자세한 내용은 디스크 설명서를 참조하십시오.

DVD에 따라 **POP-UP/MENU**를 누르면 맨 처음 메뉴가 표시되기도 합니다.

㉕ **ON SCREEN** : On Screen 메뉴(23페이지)를 표시합니다.

㉖ **ANGLE** **BD** **DVD** : 비디오가 여러 앵글로 녹화된 경우 카메라 앵글을 변경합니다. 이 기능을 사용할 수 있으면 Angle Mark()가 화면에 표시됩니다. On Screen 메뉴(23페이지)에서 이 항목을 선택할 수도 있습니다.

참고

- Angle Mark가 On으로 설정된 경우에만 Angle Mark가 표시됩니다(31페이지).

㉗ **AUDIO** **BD** **DVD** : 오디오 언어 또는 형식을 변경합니다. On Screen 메뉴(23페이지)에서 이 항목을 선택할 수도 있습니다.

ID 기능

리모콘 ID를 변경하여 DVD 플레이어 같은 다른 Yamaha 플레이어에서 필요 없는 조작용 하지 못하도록 할 수 있습니다. 리모콘 ID를 변경한 경우 기본 기기에 서 동일한 ID를 선택했는지 확인하십시오. 기본 설정은 ID1입니다.

1 리모콘 설정

ID를 ID1에서 ID2로 변경하려면 빨간색 버튼과 숫자 버튼 **2**를 동시에 7초 동안 누릅니다. ID를 ID2에서 ID1로 변경하려면 빨간색 버튼과 숫자 버튼 및 **1**을 동시에 7초 동안 동시에 누릅니다.

2 기본 기기 설정

다음과 같은 경우 앞면 패널의 **◀◀◀/▶▶▶** 및 **▶▶▶/▶▶▶**를 동시에 2초간 누르고 있으면 현재 ID가 표시됩니다.

- 플레이어에 디스크가 들어있지 않은 경우.
- 디스크 트레이가 닫혀 있는 경우.
- 재생이 중지된 경우.
- "NO DISC"가 표시창에 표시된 경우.

키를 2초 동안 더 누르고 있으면 ID가 ID1과 ID2 중에서 변경됩니다.

참고

- 리모콘 배터리를 몇 분간 빼 놓거나 다 쓴 배터리를 리모콘에 그대로 두면 리모콘 ID가 자동으로 ID 1로 설정됩니다. 리모콘을 ID2로 설정하고 사용하려면 새 배터리를 넣고 리모콘 ID를 다시 설정하십시오.

연결 방법

사용하는 비디오/오디오 기기에 맞는 연결 방법을 찾아 보십시오. 케이블 하나로 고품질의 디지털 오디오 및 비디오를 볼 수 있는 HDMI 단자를 사용하는 것이 좋습니다. 다른 단자/잭을 사용하는 경우 비디오를 먼저 연결하십시오. 그런 다음 오디오를 연결하십시오.

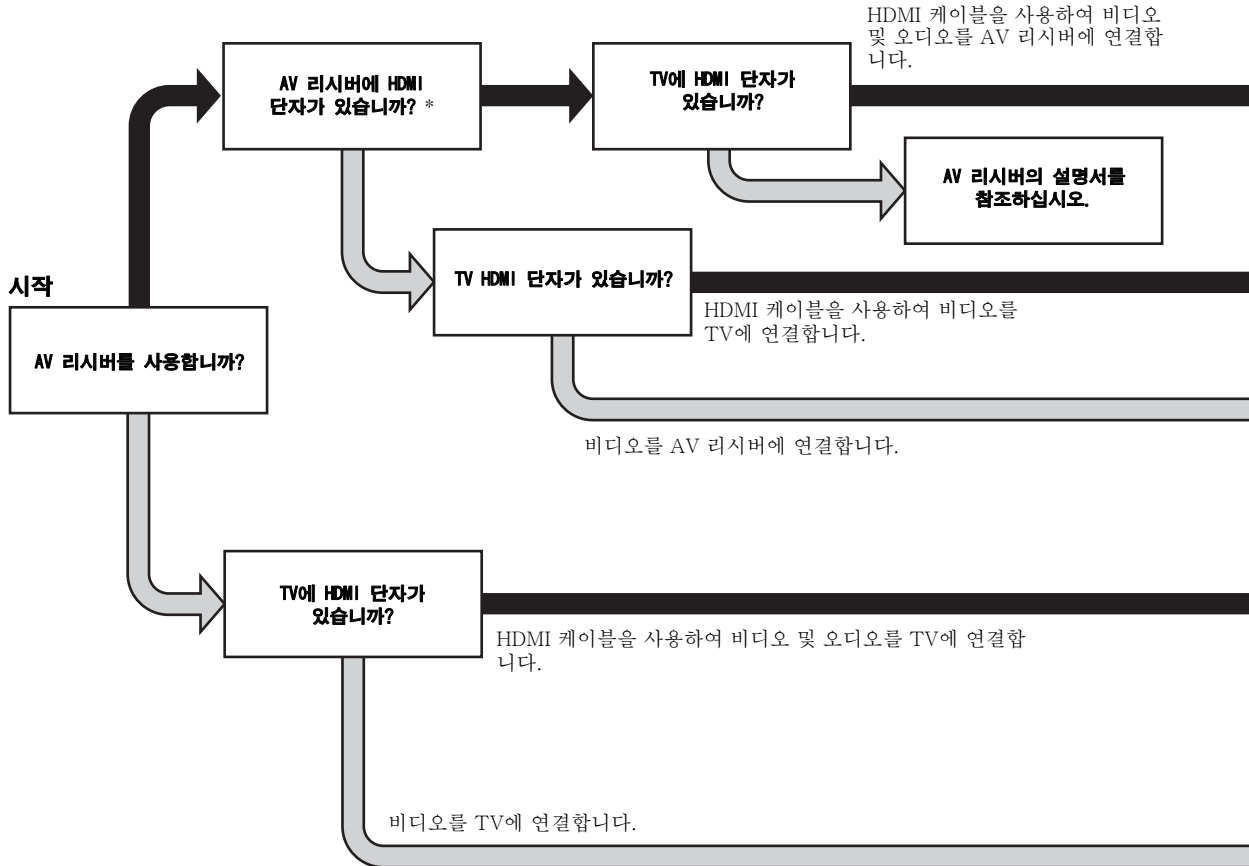

예
 아니오

* 사운드 입력이 HDMI 단자로 출력되지 않는 AV 리시버에 연결한 경우 AV 리시버의 설명서를 참조하십시오.

■ 뒷면 패널

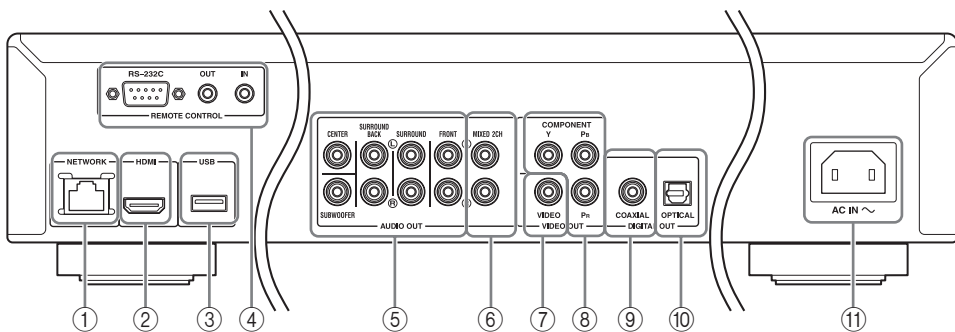

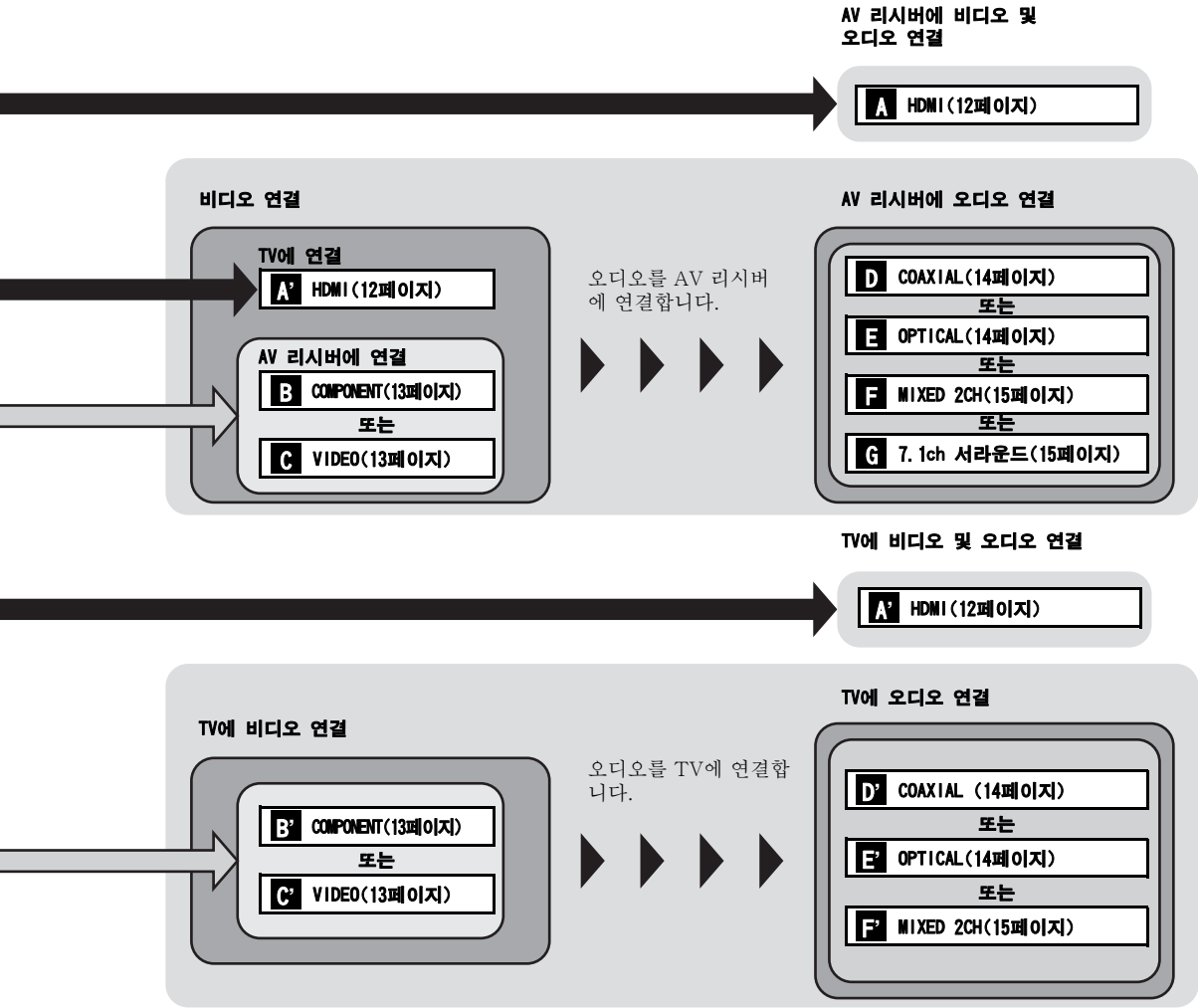

- ① NETWORK (16페이지)
- ② HDMI (12페이지)
- ③ USB 포트 (16페이지)
- ④ REMOTE CONTROL (IN/OUT/RS-232C) (17페이지)
- ⑤ 7.1ch 서라운드 (AUDIO OUT) (15페이지)

- ⑥ MIXED 2CH (AUDIO OUT) (15페이지)
- ⑦ VIDEO (13페이지)
- ⑧ COMPONENT (13페이지)
- ⑨ COAXIAL (14페이지)
- ⑩ OPTICAL (14페이지)
- ⑪ AC IN (17페이지)

HDMI 연결

■ HDMI 단자에 연결

- HDMI 단자를 통해 고품질의 디지털 사진 및 사운드를 즐길 수 있습니다.
- HDMI 케이블(시판용)을 HDMI 단자에 단단히 연결하십시오.
- 오디오/비디오 출력 형식에 대한 자세한 내용은 35페이지를 참조하십시오.
- HDMI 로고(뒷 표지에 표시되어 있음)가 있는 HIGH SPEED HDMI 케이블을 사용하십시오.

주의!

모든 연결이 완료될 때까지 본 플레이어의 전원 케이블을 연결하지 마십시오.

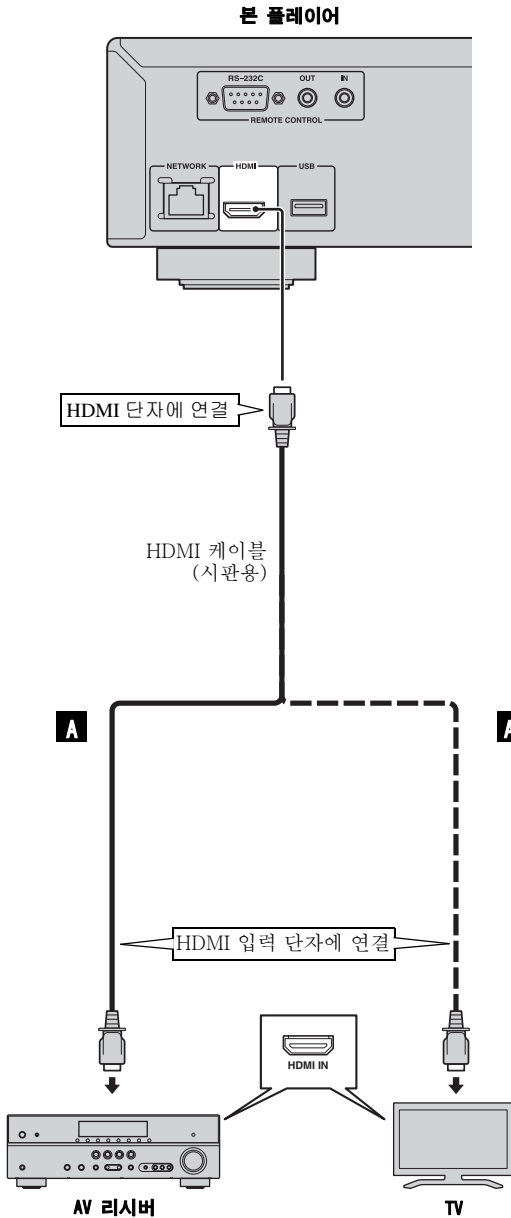

힌트

- HDMI Control 기능을 사용하는 경우 "HDMI Control"(30페이지)을 참조하십시오.
- HDMI 단자의 출력 모드에 대해서는 "HDMI"(34페이지)를 참조하십시오.
- 아무 사진도 표시되지 않으면 "문제 해결"(39페이지)을 참조하십시오.

■ Blu-ray 3D 디스크 재생을 위한 연결

본 플레이어에서 Blu-ray 3D 디스크를 재생하려면 다음과 같은 장비를 연결해야 합니다:

- 3D 기능을 갖춘 TV 및 (필요한 경우) AV 리시버
- 모든 구성품은 HDMI 케이블을 이용하여 연결해야 합니다.
- Blu-ray 디스크에는 3D 이미지가 있어야 합니다.

비디오 연결

■ 컴포넌트/비디오 잭에 연결

- 컴포넌트 잭을 통해 정확한 색상 재현과 고화질을 즐길 수 있습니다.
- 컴포넌트 비디오 케이블(시판용) 또는 비디오 핀 케이블을 COMPONENT 잭/VIDEO 잭에 단단히 연결하십시오.
- 비디오 출력 형식에 대한 자세한 내용은 36페이지를 참조하십시오.

주의!

모든 연결이 완료될 때까지 본 플레이어의 전원 케이블을 연결하지 마십시오.

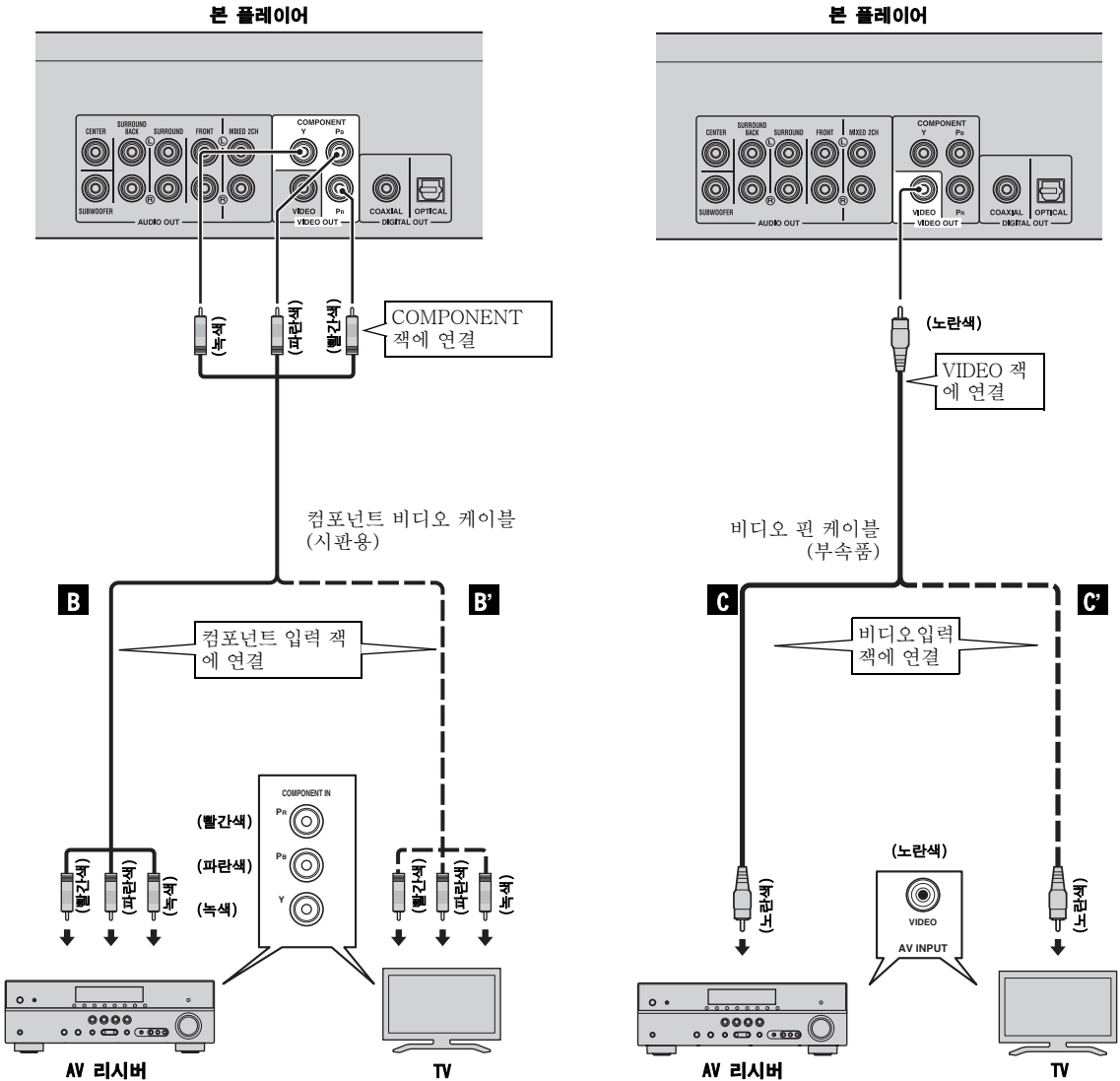

참고

- VCR을 통해 화상을 재생하는 경우 복제 방지 기능으로 인해 화질이 저하될 수 있습니다.
- 본 플레이어에서 BD-3D 디스크를 즐기려면 HDMI 케이블을 이용하여 AV 리시버, TV 및 본 플레이어를 연결해야 합니다. 이전 페이지를 참조하십시오.

오디오 연결

■ 디지털 오디오 잭/단자에 연결

- 오디오 기기 또는 TV를 COAXIAL 잭/OPTICAL 단자에 연결할 수 있습니다.
- 동축 디지털 오디오 케이블(시판용) 또는 광 케이블을 동축 디지털 오디오 잭 또는 광 디지털 오디오 단자에 단단히 연결하십시오.
- 오디오 출력 형식에 대한 자세한 내용은 35페이지를 참조하십시오.

주의!

모든 연결이 완료될 때까지 본 플레이어의 전원 케이블을 연결하지 마십시오.

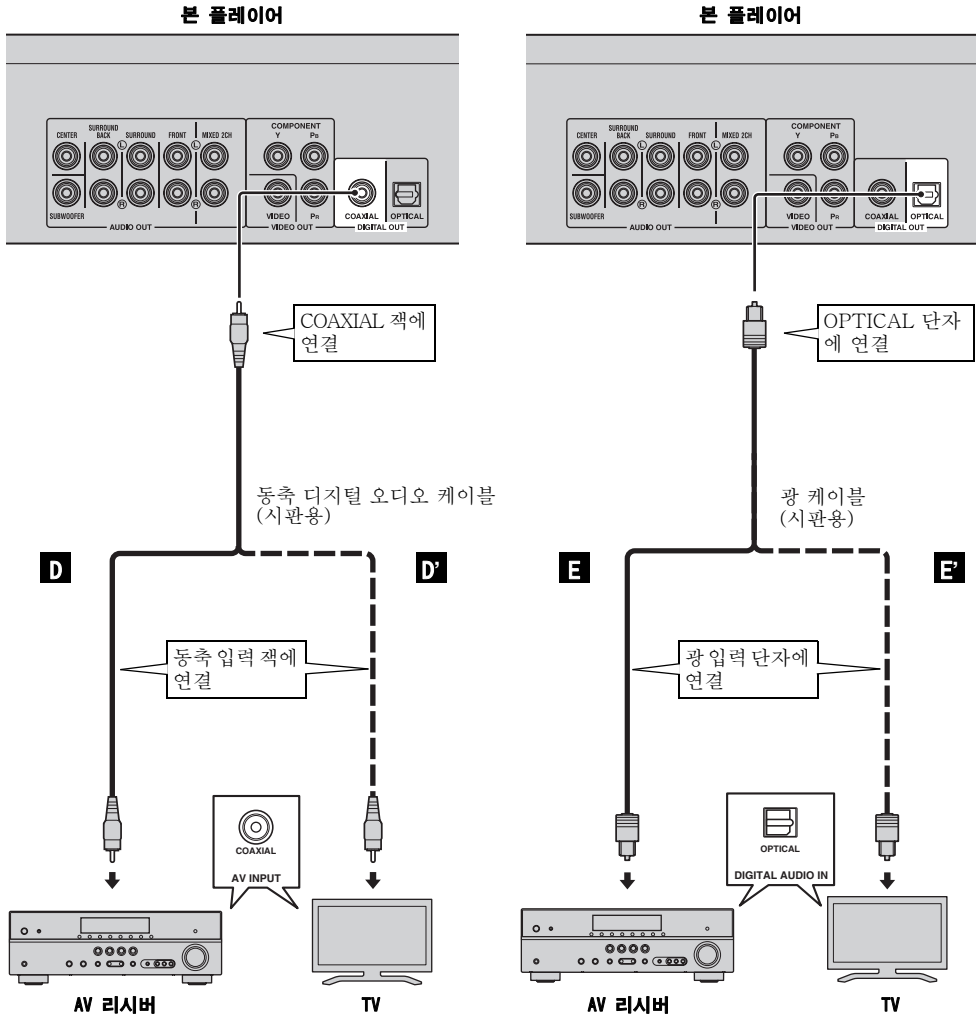

힌트

- COAXIAL 잭/OPTICAL 단자의 출력 모드에 대한 자세한 내용은 "Coaxial/Optical"(34페이지)을 참조하십시오.

■ 오디오 잭에 연결

- 오디오 기기 또는 TV를 MIXED 2CH/7.1채널 서라운드 잭에 연결할 수 있습니다.
- 오디오 핀 케이블(부속품 및 시판용)을 MIXED 2CH 잭 또는 7.1채널 서라운드 잭에 단단히 연결하십시오.
- 오디오 출력 형식에 대한 자세한 내용은 35페이지를 참조하십시오.
- 멀티 채널 SA-CD 및 DVD-Audio를 재생하려면, 시판되는 오디오 핀 케이블을 사용하여 7.1채널 서라운드 잭을 AV 리시버의 해당 입력 잭에 연결하십시오.

주의!

모든 연결이 완료될 때까지 본 플레이어의 전원 케이블을 연결하지 마십시오.

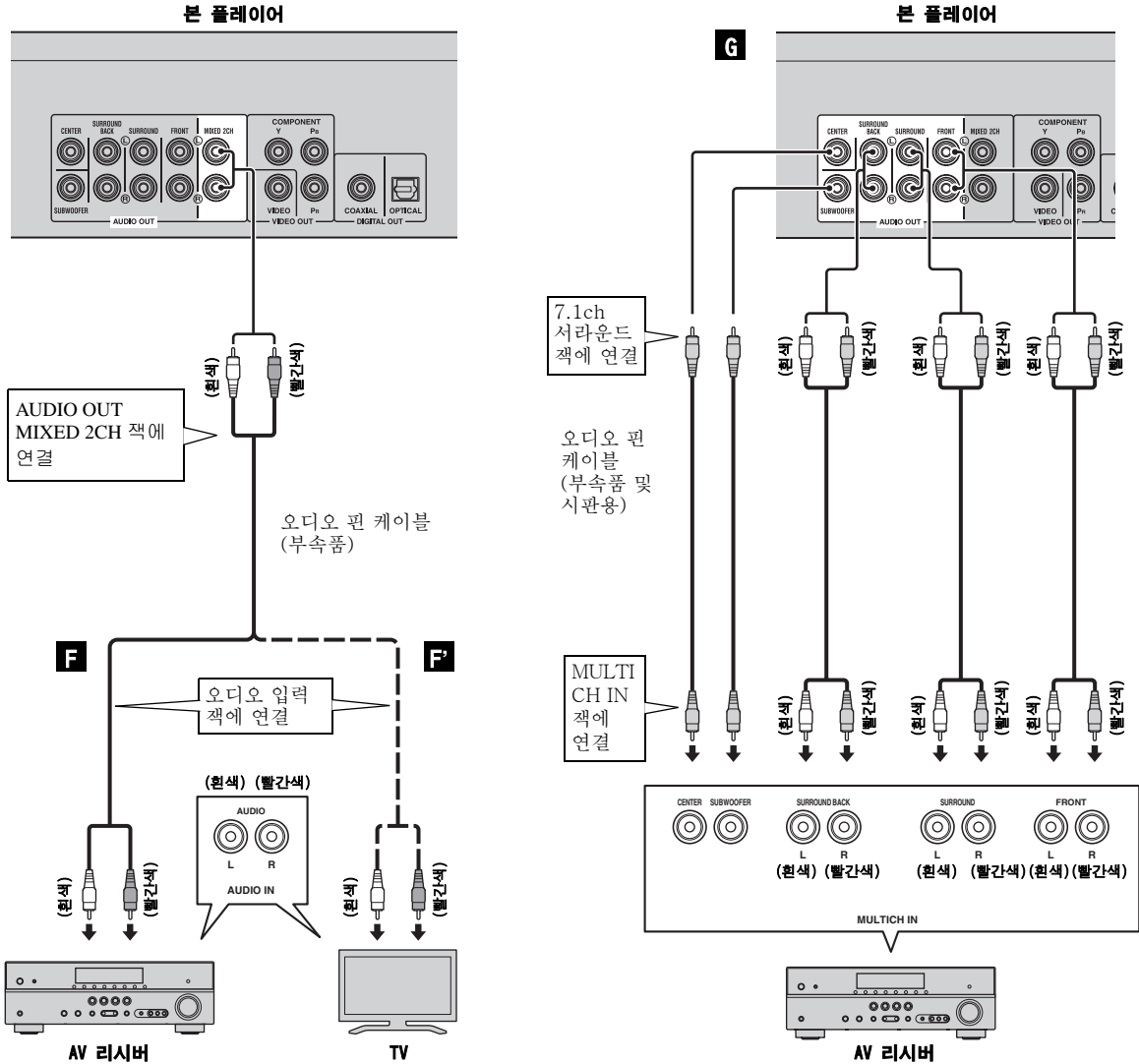

힌트

- 서브우퍼를 SUBWOOFER 잭에 직접 연결할 수 있습니다. 본 플레이어에 TV를 직접 연결할 경우, Yamaha Active Servo Processing Subwoofer System 같은 활성 서브우퍼를 이 잭에 연결하십시오.
- MIXED 2CH/7.1ch 서라운드 잭에서 오디오 신호를 출력하려면 "Speaker Setting"(34페이지)을 참조하십시오.

네트워크 및 USB 연결

■ NETWORK 단자 및 USB 포트에 연결

- 본 플레이어를 네트워크에 연결하여 PC 콘텐츠를 재생할 수 있습니다.
- BD-Live 호환 디스크를 재생하는 경우 인터넷에 연결하면 인터랙티브 기능을 가진 다양한 콘텐츠를 즐길 수 있습니다. BD-Live 기능에 대한 자세한 내용은 26페이지를 참조하십시오.
- BD Local Storage용 USB 메모리 장치(2 GB 이상, FAT 32/16으로 포맷됨)를 플레이어의 뒷면 패널(또는 앞면 패널)에 있는 USB 포트에 연결하면 BD-Live 데이터를 저장하거나 본 플레이어의 소프트웨어를 업그레이드할 수 있습니다.
- 네트워크 케이블(시판용) 및 USB 메모리 장치(시판용)를 NETWORK 단자 및 USB 포트에 단단히 연결하십시오.
- STP(shielded twisted pair) 네트워크 케이블만 사용하십시오.
- 인터넷을 사용 중일 경우 아래와 같은 광대역 인터넷 연결이 필요합니다.
- 네트워크 케이블의 다른 커넥터를 허브/광대역 라우터에 연결하십시오.

USB 메모리 장치를 사용하기 전에

주의:

- BD-Live(26페이지)를 조작하거나 소프트웨어 업그레이드를 수행 중일 때는 USB 메모리 장치를 분리하거나 전원 케이블을 뽑지 마십시오.
- USB 메모리 장치를 본 플레이어의 USB 포트에 연결할 때 USB 확장 케이블을 사용하지 마십시오. USB 확장 케이블을 사용하면 플레이어가 올바르게 실행되지 않을 수 있습니다.

참고

- Yamaha는 본 플레이어에서 모든 브랜드의 USB 메모리 장치가 작동된다고 보증하지 않습니다.

참고

- 광대역 인터넷 연결을 사용하는 경우 인터넷 서비스 제공자와 계약을 해야 합니다. 자세한 내용은 가까운 인터넷 서비스 제공자에 문의하십시오.
- 인터넷 환경에 따라 연결하는 기기 및 연결 방법이 다를 수 있으므로 사용하는 기기의 사용 설명서를 참조하십시오.
- 10BASE-T/100BASE-TX를 지원하는 네트워크 케이블/라우터를 사용하십시오.

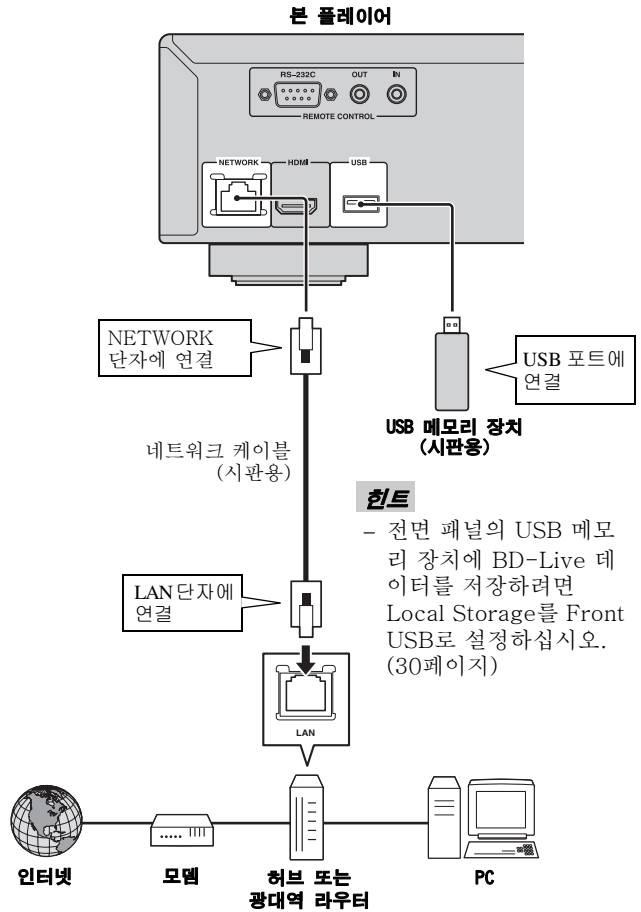

힌트

- 전면 패널의 USB 메모리 장치에 BD-Live 데이터를 저장하려면 Local Storage를 Front USB로 설정하십시오. (30페이지)

연결한 후에

- Network 설정을 수동으로 설정하려면 "Network"(32페이지)를 참조하십시오.
- 네트워크에서 PC 콘텐츠를 재생하려면 "네트워크 콘텐츠 사용"(21페이지)을 참조하십시오.

기타 연결

■ REMOTE CONTROL 잭에 연결

- REMOTE CONTROL(OUT/IN) 잭에 연결하면 리모콘 신호를 전송 및 수신할 수 있습니다.
- 모노 3.5 mm 미니 플러그 케이블(시판용)을 REMOTE CONTROL(OUT/IN) 잭에 단단히 연결하십시오.
- AV 리시버가 SCENE 제어 신호 전송 기능이 있는 Yamaha 제품인 경우 SCENE 기능을 사용하여 본 플레이어를 제어할 수 있습니다.

주의!

모든 연결이 완료될 때까지 본 플레이어의 전원 케이블을 연결하지 마십시오.

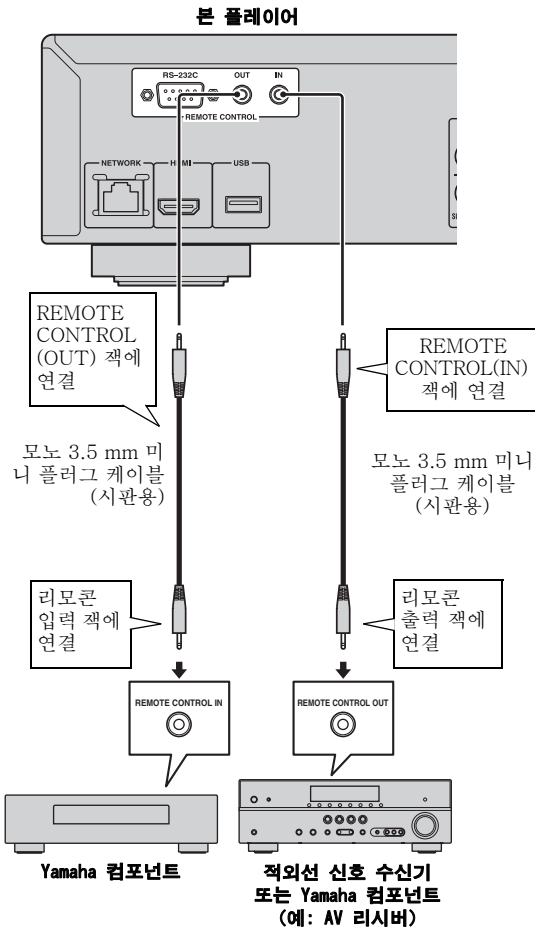

힌트

- SCENE 기능에 대한 자세한 내용은 Yamaha AV 리시버에 부착된 설명서를 참조하십시오.

- SCENE 기능이 지원되는 Yamaha 컴포넌트(예: CD 플레이어)를 본 플레이어의 REMOTE CONTROL (OUT) 잭에 연결할 수 있습니다.
- RS-232C 단자는 시판되는 제어 확장 단자입니다. 자세한 내용은 가까운 대리점에 문의하십시오.

■ 전원 케이블 연결

- 모든 연결을 완료한 후 부착된 전원 케이블을 플레이어 뒷면의 AC IN에 꽂으십시오. 그런 다음 AC 전원에 꽂으십시오.

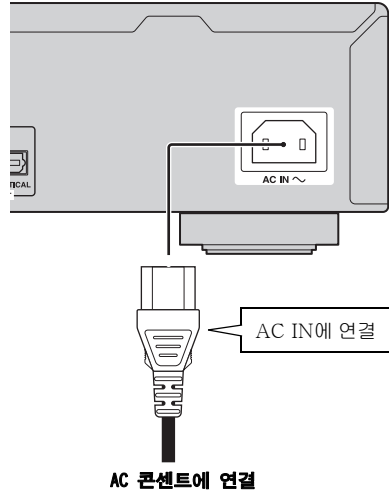

참고

- 감전 사고를 방지하려면 전원 케이블이 연결된 경우 케이블에서 절연되지 않은 부분을 만지지 마십시오.

INITIAL WIZARD/EASY SETUP

■ Initial Wizard/Easy Setup을 사용하여 설정

Initial Wizard/Easy Setup을 사용하면 언어, 해상도 및 화면 비율을 간편하게 설정할 수 있습니다. 본 플레이어를 구입하거나 업그레이드 한 후 처음으로 켜면 Initial Wizard 화면이 표시됩니다. SETUP 메뉴 → System → Easy Setup에서 이와 같은 설정을 할 수도 있습니다.

1 Easy Setup 화면이 표시된 경우 **ENTER**를 누르면 Easy Setup이 시작됩니다.

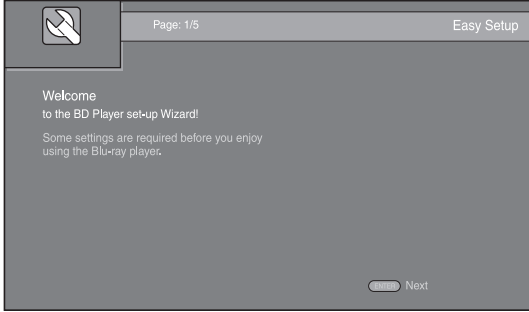

2 ▲/▼를 눌러 화면에 표시하려는 언어를 선택한 다음, **ENTER**를 누릅니다.

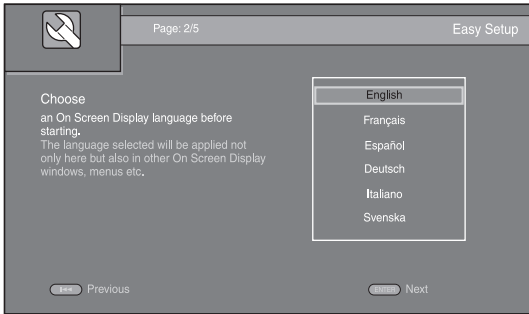

3 ▲/▼를 눌러 해상도를 선택한 다음, **ENTER**를 누릅니다. 설정 항목에 대한 자세한 내용은 "Resolution"(33페이지)를 참조하십시오.

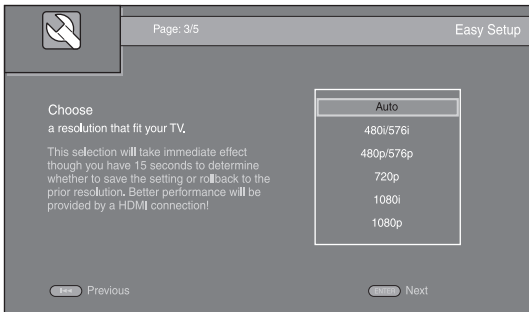

4 ▲/▼를 눌러 화면 비율을 선택한 다음, **ENTER**를 누릅니다. 설정 항목에 대한 자세한 내용은 "TV Screen"(32페이지)을 참조하십시오. Easy Setup이 완료되었습니다.

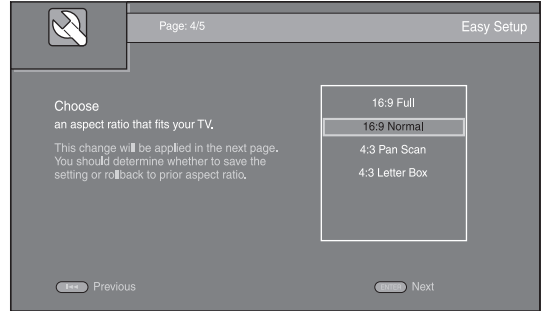

5 **ENTER**를 눌러 Easy Setup을 종료합니다.

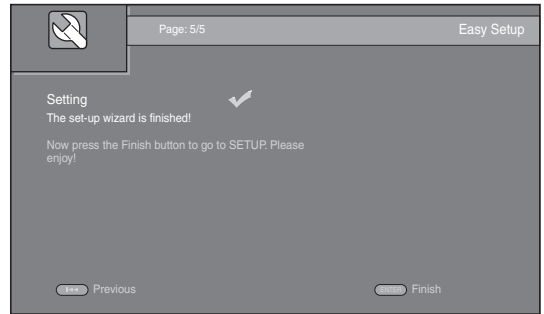

참고

- Initial Wizard/Easy Setup이 완료된 후에 아무 사 진도 표시되지 않으면 "문제 해결"(39페이지)을 참조하십시오.
- 본 플레이어를 켜면 3D 비디오 재생에 관한 경고 메시지가 표시됩니다. **ENTER**를 눌러 메시지를 닫거나 **CLEAR**를 눌러 메시지를 비활성화하십시오. (30페이지)

HOME/MEDIA 메뉴

HOME 및 MEDIA 메뉴를 사용하면 데이터 디스크, USB 메모리 장치 및 네트워크에서 멀티미디어 파일을 찾아 재생할 수 있습니다.

참고

- 재생 가능한 디스크 및 형식에 대한 자세한 내용은 3페이지를 참조하십시오.

■ 사진/음악/비디오 재생

기본 조작

- ▲/▼: 초점을 이동합니다.
- ◀: 상위 폴더로 돌아갑니다.
- ▶: 단일 폴더/파일을 선택/선택 해제합니다.
- HOME: HOME 메뉴 화면으로 이동/종료합니다.
- ENTER: 폴더/파일을 확인합니다.

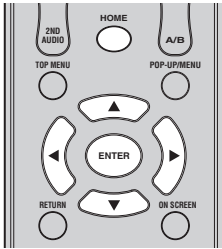

MEDIA 메뉴 상단의 아이콘

- : 트레이에 있는 디스크를 재생하거나 데이터 디스크의 내용을 표시합니다.
- : USB 포트에 연결된 USB 메모리 장치의 내용을 표시합니다.
- : 네트워크에서 DLNA(21페이지) 서버를 검색합니다.
- : 연결된 DLNA 서버의 내용을 표시합니다.

선택한 폴더의 파일 재생 시 일반적인 조작

예: USB 메모리 장치에서 동영상 파일 선택

참고

- MEDIA 메뉴 화면으로 이동하기 전에 비디오 재생을 중지하십시오.
- 1 HOME을 눌러 HOME 메뉴 화면으로 이동합니다.
◀/▶를 눌러 MEDIA를 선택한 다음, ENTER를 누릅니다.

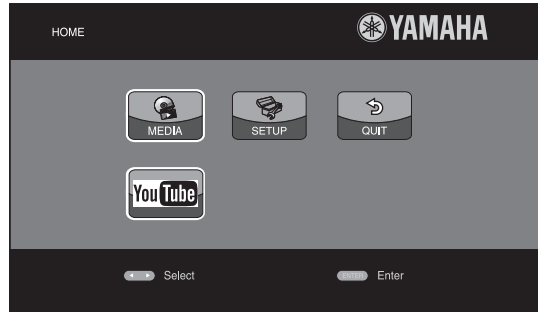

- 2 MEDIA 화면이 나타납니다.

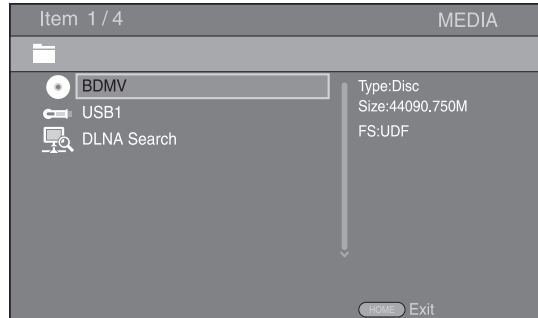

- 3 재생하려는 파일이 포함된 항목을 선택한 다음, ENTER를 누릅니다.

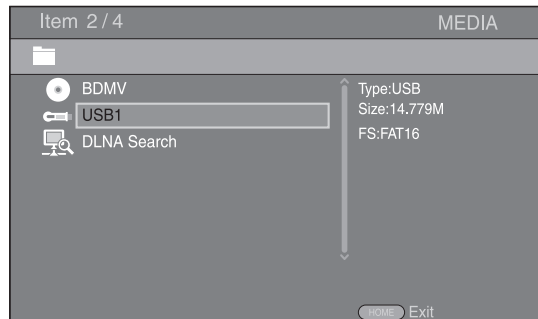

- 4 재생하려는 Photo, Music, Video 또는 AVCHD 폴더를 선택한 다음, **ENTER**를 누릅니다. 상위 폴더로 돌아가려면 ◀를 누르거나 ▶를 선택합니다.

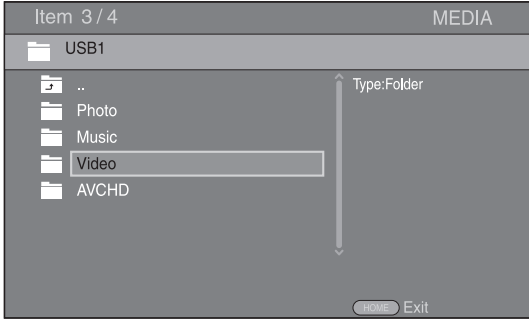

참고

- 이 단계에서 선택한 파일 유형만 다음 단계에 표시됩니다. 예를 들어, 이 단계에서 Photo 폴더를 선택한 경우 다음 단계에서는 사진 파일만 표시됩니다. 사진 이외의 다른 것을 재생하려면 이 계층으로 돌아가 파일 유형을 다시 선택하십시오.

- 5 재생하려는 파일이 포함된 폴더를 선택합니다.

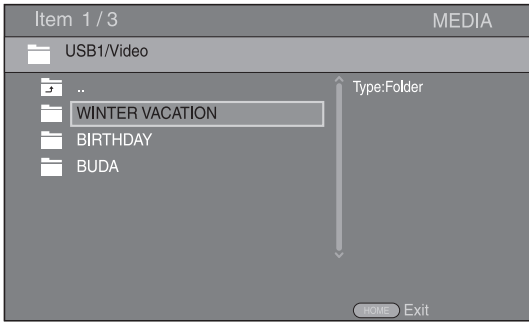

- 6 재생하려는 파일을 선택한 다음, **ENTER**를 누릅니다. 비디오 파일을 선택한 경우 재생이 시작됩니다. 음악 파일을 선택한 경우 상태 화면이 표시되고 재생이 시작됩니다. 사진 파일을 선택한 경우 슬라이드 쇼가 시작됩니다.

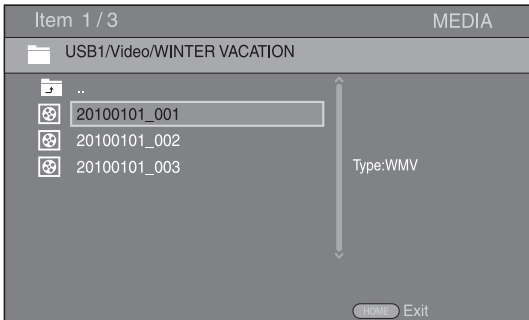

힌트

- 음악이 있는 슬라이드 쇼를 즐기려면, 음악이 재생되는 동안 **HOME**을 눌러 HOME 메뉴 화면으로 돌아가 사진 파일을 선택합니다.

참고

- 파일 내용에 따라 표시된 파일이 재생되지 않을 수 있습니다.

사진을 보기 위한 조작

사진을 보는 동안에는 리모콘 버튼이 아래와 같이 작동합니다.

- : 슬라이드 쇼를 정지하고 파일 찾아보기로 돌아옵니다.
- : 슬라이드 쇼를 일시 정지합니다.
- ▶: 슬라이드 쇼를 재생합니다.
- ▶▶: 다음 사진으로 이동합니다.
- ◀◀: 이전 사진으로 이동합니다.
- ▶▶▶: 슬라이드 쇼의 속도가 3단계로 빨라집니다.
- ◀◀◀: 슬라이드 쇼의 속도가 3단계로 느려집니다.
- ▲: 사진을 뒤집습니다.
- ▼: 사진을 반사합니다.
- ◀: 사진을 시계 반대 방향으로 회전합니다.
- ▶: 사진을 시계 방향으로 회전합니다.

ZOOM: 사진을 확대/축소합니다(확대/축소: 각각 3단계). ▲/▼/◀/▶: 사진이 화면보다 클 경우 줌 모드에서 이동합니다.

DIGEST: 썸네일 모드(7페이지)로 전환합니다. 썸네일이 표시된 경우 ◀◀◀/▶▶▶를 사용하여 이전/다음 페이지로 이동할 수 있습니다.

■ 네트워크 콘텐츠 사용

본 플레이어는 DLNA 인증 디지털 미디어 플레이어입니다. 사용자의 홈 네트워크에서 DLNA 서버에 저장된 사진, 음악 및 비디오 콘텐츠를 관리할 수 있습니다.

DLNA에 대하여

DLNA(Digital Living Network Alliance)는 가정에서 네트워크를 통해 디지털 미디어를 간편하게 공유할 수 있으며, DLNA 서버 소프트웨어가 설치된 PC 또는 다른 DLNA 호환 장치에 저장된 디지털 콘텐츠를 본 플레이어 통해 TV에서 즐길 수 있습니다. 본 플레이어를 DLNA 서버에 연결하려면 DLNA 서버 또는 장치를 일부 설정해야 합니다. 자세한 내용은 DLNA 서버 소프트웨어 또는 DLNA 장치를 참조하십시오.

공유 콘텐츠 재생

- 1 PC에서 파일을 재생하려면, Windows Media Player 12 같은 DLNA 서버 소프트웨어를 설치하고 재생하려는 파일을 공유합니다.
- 2 DLNA 서버 소프트웨어가 설치된 PC 또는 홈 네트워크에 연결된 DLNA 장치를 켭니다.
- 3 **HOME**을 눌러 HOME 메뉴 화면을 표시합니다. 그런 다음 **MEDIA**를 선택하여 MEDIA 메뉴로 이동합니다. 네트워크에 연결된 DLNA 서버가 화면에 표시됩니다.

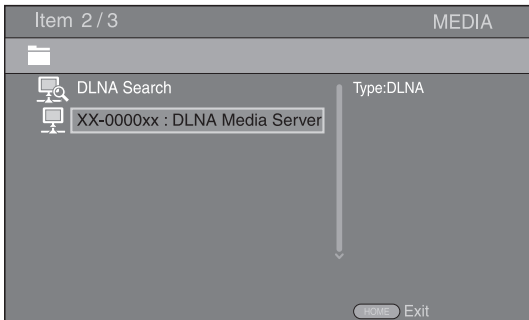

참고

- 사용하는 DLNA 서버가 표시되지 않을 경우 DLNA Search를 선택하고 서버를 찾아보십시오.
 - DLNA 서버에 따라 서버에서 본 플레이어를 허가해야 할 수도 있습니다.
 - DLNA 서버에서 파일을 재생하려면 본 플레이어와 서버가 동일한 액세스 포인트에 연결되어 있어야 합니다.
 - 파일 요구 사항이 호환되지 않을 수도 있습니다. 파일 특징 및 DLNA 서버 용량에 따라 일부 제한이 있을 수 있습니다.
- 4 재생하려는 파일을 선택합니다.

참고

- 홈 네트워크 조건에 따라 재생 및 작동 상태에 영향을 미칠 수도 있습니다.
- USB 메모리 장치 또는 미디어 서버의 DVD 드라이브 같은 이동식 매체의 파일이 올바르게 공유되지 않을 수 있습니다.

네트워크 서비스 사용

아래의 네트워크에서 제공하는 비디오를 즉시 시청할 수 있습니다.

- YouTube

참고

- 타사가 제공하는 콘텐츠에 접근하려면 고속 인터넷 연결이 필요하며, 계정 등록 및 유료 구독이 필요할 수도 있습니다.
- 타사가 제공하는 콘텐츠 서비스는 예고 없이 언제든지 변경, 보류, 중단, 또는 중지될 수 있으며, 이와 관련하여 Yamaha에게는 어떠한 책임도 없습니다.
- 일부 콘텐츠는 특정 국가에서만 사용이 가능할 수 있으며 일부 언어로만 제공될 수도 있습니다.
- Yamaha는 특정 기간 동안의 콘텐츠 서비스에 대한 지속적 제공이나 가용성에 대한 진술이나 보증을 제공하지 않으며, 명시적이든 암묵적이든 그러한 모든 보증에 대한 책임이 없습니다.

YouTube™에서 비디오 재생

본 플레이어를 이용하여 인터넷을 통해 YouTube에서 영화를 시청할 수 있습니다.

해당 서비스들은 예고 없이 변경될 수 있습니다.

- 1 **HOME**을 눌러 HOME 메뉴 화면을 표시합니다.

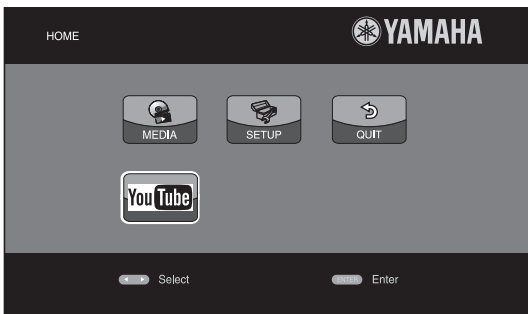

힌트

- 모델에 따라 HOME 메뉴 화면은 다를 수 있습니다.

- 2 **▲/▼/◀/▶**를 눌러 YouTube를 선택한 다음, **ENTER**를 누릅니다.

힌트

- HOME 메뉴 화면으로 돌아가려면 **RETURN**을 누릅니다.

고급 재생 조작

이 장에서는 시판용 BD 및 DVD 디스크, SA-CD, CD 및 녹화된 DVD-RW/R 디스크의 재생에 대해 설명합니다.

참고

- 기본적인 재생 조작에 대해서는 6페이지를 참조하십시오.

■ On Screen 메뉴

On Screen 메뉴를 표시하려면 **ON SCREEN**을 누릅니다. 그런 다음, ▲/▼/◀/▶를 눌러 항목을 선택하고, **ENTER**를 눌러 원하는 기능을 조작합니다.

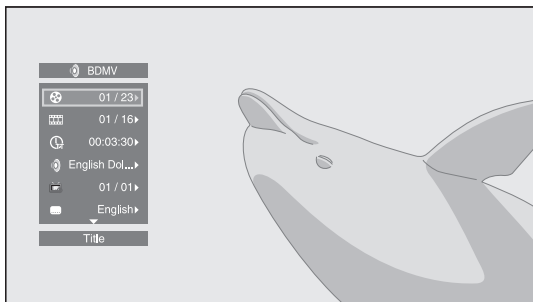

On Screen 메뉴에 포함된 항목은 다음과 같습니다.

Title [BD] [DVD] [VIDEO]: 재생 중인 타이틀 번호를 표시합니다. 이 항목에서 타이틀을 선택하여 원하는 타이틀로 건너뛸 수 있습니다.

Chapter [BD] [DVD] [VIDEO]: 재생 중인 챕터 번호를 표시합니다. 이 항목에서 챕터를 선택하여 원하는 챕터로 건너뛸 수 있습니다.

Track/File [CD] [VIDEO] [MUSIC] [PHOTO]: 재생 중인 트랙/파일 번호를 표시합니다. 이 항목에서 트랙/파일을 선택하여 원하는 트랙/파일로 건너뛸 수 있습니다.

Time [BD] [DVD] [CD] [VIDEO] [MUSIC]: 재생 시간을 표시합니다. 다음 중에서 표시 유형을 선택합니다.

- 타이틀, 챕터, 디스크, 트랙 또는 파일의 경과된 재생 시간
- 타이틀, 챕터, 디스크, 트랙 또는 파일의 남아 있는 재생 시간

Mode/Play Mode

[DVD] [CD] [VIDEO] [MUSIC] [PHOTO]: 현재 재생 모드를 표시합니다. 다음 중에서 재생 모드를 선택할 수 있습니다.

[CD]

- Normal: 일반 재생.
- Shuffle: 반복 없이 무작위 재생.
- Random: 반복하여 무작위 재생.

[DVD]

- Normal
- Shuffle CH (챕터)
- Shuffle TT (타이틀)
- Shuffle All
- Random CH (챕터)
- Random TT (타이틀)
- Random All

[VIDEO] [MUSIC] [PHOTO]

- Normal
- Shuffle F (폴더)
- Shuffle All
- Random F (폴더)
- Random All

Audio [BD] [DVD] [VIDEO]: 현재 선택된 BD/DVD 디스크의 오디오 언어/신호를 표시합니다. 원하는 오디오 유형을 선택할 수 있습니다.

Angle [BD] [DVD]: 현재 선택된 앵글을 표시합니다. 비디오가 여러 앵글로 녹화된 경우 앵글을 변경할 수 있습니다.

Subtitle [BD] [DVD] [VIDEO]: 자막이 제공되는 경우 현재 선택된 자막 언어를 표시합니다.

Subtitle Style [BD]: 현재 선택된 자막 스타일을 표시합니다. 이 기능은 비디오 파일 외부 자막인 경우에만 사용할 수 있습니다. 자막의 텍스트 스타일을 선택할 수 있습니다.

Bitrate [BD] [DVD] [CD] [VIDEO] [MUSIC]: 오디오/비디오 신호의 비트 전송률을 표시합니다.

Second Video [BD]: PIP를 설정/해제합니다(6페이지).

Second Audio [BD]: 보조 오디오를 설정/해제합니다(6페이지).

Ins Search

[BD] [DVD] [CD] [VIDEO] [MUSIC]: 30초를 건너뛸니다.

Ins Replay

[BD] [DVD] [CD] [VIDEO] [MUSIC]: 10초 전의 내용부터 다시 봅니다.

Slide Show [PHOTO]

슬라이드 쇼의 속도를 표시합니다. Slow/Medium/Fast 중에서 슬라이드 쇼의 속도를 선택할 수 있습니다.

Transition [PHOTO]: 화면에 사진이 나타나는 방법을 표시합니다. 전환 유형을 선택할 수 있습니다.

Code Page [VIDEO]: DivX 비디오(41페이지)에 추가된 자막의 문자 코드를 선택합니다.

■ 상태 메뉴

자막, 앵글 설정 및 현재 재생된 타이틀/챕터/트랙 번호 등 다양한 설정을 표시합니다. 상태 메뉴를 표시하려면 **STATUS**를 누릅니다. 상태 메뉴에는 다음과 같은 메뉴가 포함되어 있습니다.

BD DVD VIDEO

예: BD 재생 시 아이콘

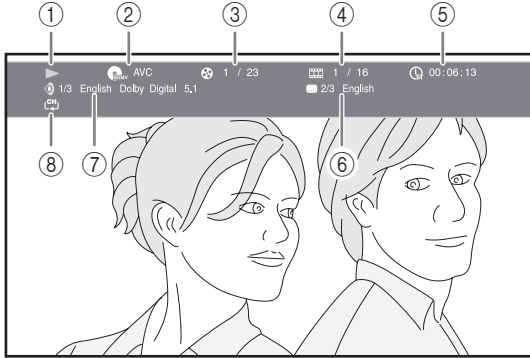

- ① ▶ (재생 상태)
- ② **BDMV** (디스크 유형/비디오 파일 아이콘)
- ③ **1 / 23** (재생 중인 타이틀 번호): **SEARCH** 버튼(8페이지)을 사용하여 지정한 타이틀로 이동할 수 있습니다.
- ④ **1 / 16** (재생 중인 챕터 번호): **SEARCH** 버튼(8페이지)을 사용하여 지정한 챕터로 이동할 수 있습니다.
- ⑤ **00:06:13** (경과된 재생 시간): **SEARCH** 버튼(8페이지)을 사용하여 지정한 지점으로 이동할 수 있습니다.
- ⑥ **English** (현재 선택된 자막): **SUBTITLE** 버튼을 사용하여 자막 언어를 변경할 수 있습니다.
- ⑦ **Dolby Digital 5.1** (현재 선택된 오디오): **AUDIO** 버튼을 사용하여 오디오 언어 또는 형식을 변경할 수 있습니다.
- ⑧ **1 / 3** (반복 모드): 현재 반복 모드(8페이지)를 표시합니다.

DVD CD MUSIC

예: 음악 파일 재생 시 아이콘

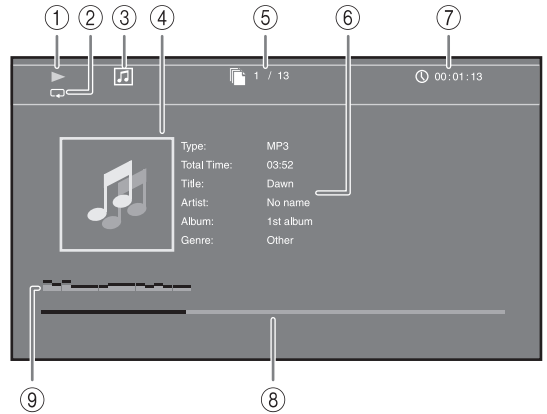

- ① ▶ (재생 상태)
- ② **↺** (반복 모드): 현재 반복 모드(8페이지)를 표시합니다.
- ③ **MUSIC** (디스크 유형/음악 파일 아이콘)
- ④ **MUSIC** (아트워크): 파일에 아트워크가 포함된 경우 아트워크를 표시합니다.
- ⑤ **1 / 13** (재생 중인 트랙/파일 번호): **SEARCH** 버튼(8페이지)을 사용하여 지정한 트랙으로 이동할 수 있습니다.
- ⑥ **03:52** (정보) **MUSIC**: 파일에 음악 정보가 포함된 경우 음악 정보를 표시합니다.
- ⑦ **00:01:13** (경과된 재생 시간): **SEARCH** 버튼(8페이지)을 사용하여 지정한 지점으로 이동할 수 있습니다.
- ⑧ **1st album** (진행률 막대) **MUSIC**: 현재 곡의 진행 상태를 표시합니다.
- ⑨ **Other** (오디오 레벨 측정계): 현재의 음량 레벨을 표시합니다.

PHOTO



- ① ▶ (재생 상태)
- ② **PHOTO** (사진 파일 아이콘)
- ③ **1 / 13** (표시되어 있는 파일 번호)
- ④ **↺** (반복 모드): 현재 반복 모드(8페이지)를 표시합니다.
- ⑤ **Slide Show: Medium** (슬라이드 쇼 속도)

■ Bookmark 사용 **DVD** **VIDEO**

이 기능을 사용하면 비디오에서 지정한 지점에 Bookmark를 설정할 수 있습니다. Bookmark를 설정하면, 이 기능을 사용하여 설정한 지점으로 이동할 수 있습니다. 북마크를 12개까지 설정할 수 있습니다.

- 1 동영상 재생 도중 **MARKER**를 눌러 Bookmark를 설정합니다. Bookmark 번호 및 상태가 표시됩니다.



- 2 Bookmark를 설정한 다음, **DIGEST**를 눌러 Bookmark 선택 막대를 표시합니다.



- 3 </>를 눌러 재생하려는 Bookmark를 선택한 다음, **ENTER**를 누릅니다. 선택한 Bookmark를 삭제하려면 **CLEAR**를 누릅니다.

참고

- 재생이 끝나면(예: 디스크 꺼내기, ■ 두 번 누르기) 북마크가 자동으로 삭제됩니다.

■ 프로그램 재생 **DVD** **CD**

오디오 디스크 트랙 또는 DVD 챕터의 재생 순서를 프로그램 재생할 수 있습니다.

재생 도중 **PROGRAM**을 눌러 PROGRAM 창을 표시하고 재생 순서를 프로그래밍합니다. 최대 15개의 트랙/챕터를 프로그래밍할 수 있습니다.

예: CD 트랙의 재생 순서 프로그래밍

- 1 재생 도중 **PROGRAM**을 누릅니다.

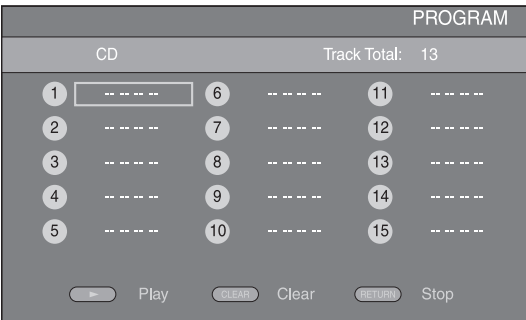

- 2 **ENTER**를 눌러 재생 순서를 프로그래밍합니다.

오디오 디스크의 경우, ▲/▼를 눌러 원하는 트랙을 선택한 다음 **ENTER**를 누릅니다.

DVD-Video 디스크의 경우, 트랙 대신 원하는 타이틀(TT로 표시됨) 및 챕터(CH로 표시됨)를 선택합니다.

설정 트랙을 지우려면, 지우려는 트랙을 선택한 다음 **CLEAR**를 누릅니다.

프로그램 재생을 취소하려면 **RETURN**을 누릅니다.

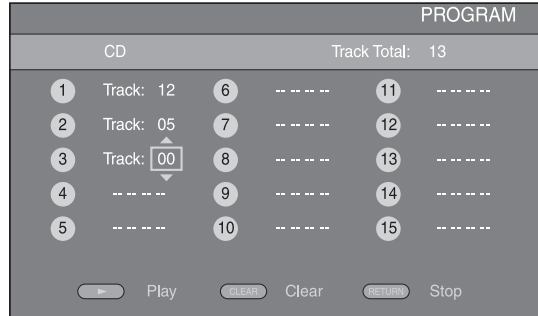

- 3 프로그래밍을 완료한 다음, ▶를 눌러 설정하면 프로그램 재생이 시작됩니다.

- 4 프로그램 재생을 취소하려면 ■를 두 번 눌러 재생을 완전히 중지합니다.

■ 검색 사용

BD **DVD** **CD** **VIDEO** **MUSIC**

재생 도중 지정한 지점으로 이동할 수 있습니다.

- 1 재생 도중 **SEARCH**를 누릅니다. 상태 표시줄이 나타납니다.

- 2 ▲/▼/◀/▶를 눌러 아래 항목 중 하나를 선택한 다음, **ENTER**를 누릅니다.

BD **DVD** :

- 타이틀 번호(Ⓢ로 표시됨)
- 챕터 번호(Ⓜ로 표시됨)
- 타이틀 경과 시간(Ⓛ로 표시됨)
- 챕터 경과 시간(ⓐ로 표시됨)

CD :

- 트랙 번호(Ⓢ로 표시됨)
- 트랙 경과 시간(ⓐ로 표시됨)
- 디스크 경과 시간(Ⓛ로 표시됨)

VIDEO **MUSIC** :

- 파일 번호(Ⓛ로 표시됨)
- 파일 경과 시간(ⓐ로 표시됨)

- 3 ▲/▼ 또는 숫자 버튼을 눌러 초점을 맞춘 항목의 값을 설정/조정하고, **ENTER**를 눌러 지정한 지점으로 이동합니다.

- 4 상태 표시줄을 닫으려면 **STATUS**를 누릅니다.

■ BONUSVIEW™ 및 BD-Live™ 즐기기

본 플레이어는 BONUSVIEW(41페이지)(BD-ROM Profile 1 버전 1.1) 및 BD-Live(41페이지)(BD-ROM Profile 2) 재생 기능을 지원합니다.

참고

- 기능 및 재생 방법은 디스크에 따라 다릅니다. 디스크 안내 또는 부속된 사용 설명서를 참조하십시오.

■ Picture in Picture 기능 사용 (보조 오디오/비디오 재생)

Picture in Picture와 호환되는 보조 오디오 및 비디오가 포함된 BD-Video에서 보조 오디오 및 비디오를 화면 구석에 작은 비디오로 동시에 재생할 수 있습니다.

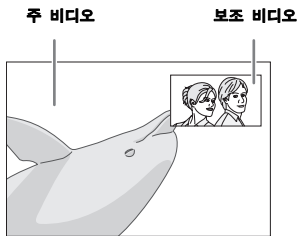

PIP Mark(PIP) 또는 Secondary Audio Mark(SA)가 표시된 상태에서 PIP를 누르면 Picture in Picture 기능이 설정/해제됩니다.

참고

- 보조 오디오를 들으려면, Audio Output 설정 (Coaxial/Optical 또는 HDMI)이 PCM 또는 Reencode(34페이지)로 설정되어 있는지 확인하십시오.
- 디스크에 따라 보조 오디오를 들으려면 디스크의 맨 처음 메뉴에서 보조 오디오를 설정해야 할 수도 있습니다(7페이지).
- Picture in Picture의 보조 오디오 및 비디오는 콘텐츠에 따라 자동으로 재생되기도 하고 삭제되기도 합니다. 또한 재생 가능한 영역이 제한되기도 합니다.

■ BD-Live™ 기능 사용

1. 네트워크 설정(32페이지)을 설정합니다.

2. USB 메모리 장치를 본 플레이어에 연결합니다(16페이지).

BD-Live 데이터가 본 플레이어에 연결된 USB 메모리 장치에 저장됩니다. 이 기능을 사용하려면 2.0 High Speed(480 Mbit/s)를 지원하는 USB 메모리 장치(2GB 이상, FAT 32/16 포맷)를 Local Storage에서 선택한 USB 포트에 연결하십시오 (30페이지). 기본 설정은 후면 패널에 있는 USB 포트입니다.

- 필요할 경우 USB 메모리 장치에 BUDA 폴더가 자동으로 생성됩니다.
- 저장 공간이 충분하지 않을 경우 데이터가 복사/다운로드되지 않습니다. 불필요한 데이터를 삭제하거나 새 USB 메모리 장치를 사용하십시오.
- 데이터를 로드(읽기/쓰기)하는 데 시간이 걸릴 수 있습니다.

참고

- Yamaha는 본 플레이어에서 모든 브랜드의 USB 메모리 장치가 작동된다고 보증하지 않습니다.
- USB 메모리 장치를 플레이어의 USB 포트에 연결할 때 USB 확장 케이블을 사용하지 마십시오. USB 확장 케이블을 사용하면 플레이어가 올바르게 실행되지 않을 수 있습니다.

3. 디스크를 재생합니다.

4. 디스크 설명서에 따라 BD-Live를 실행합니다.



참고

- BD-Live 콘텐츠 등의 재생 방법은 BD 디스크 설명서의 지침에 따라 조작하십시오.
- BD-Live 기능을 사용하려면, 네트워크 연결(16페이지) 및 Network 설정(32페이지)을 수행하십시오.
- BD-Live 콘텐츠에 대한 액세스를 제한하는 설정 방법에 대해서는 "BD-Live Connection"(32페이지)을 참조하십시오.
- 부속된 프로그램을 본 플레이어에 연결된 USB 메모리 장치로 다운로드하는 데 필요한 시간은 인터넷 연결 속도 및 프로그램의 데이터량에 따라 다릅니다.
- 인터넷을 통해 제공된 BD-Live 프로그램은 서비스 제공자의 상태(업그레이드)에 따라 연결이 표시되지 않을 수 있습니다. 이 경우 디스크를 꺼내고 다시 시도해 보십시오.
- BD 디스크 메뉴에서 BD-Live 기능을 선택한 후에도 BD-Live 화면이 표시되지 않을 경우, USB 메모리 장치에 여유 공간이 충분하지 않을 수 있습니다. 이 경우 플레이어에서 디스크를 꺼낸 다음, "Local Storage"(30페이지)의 "Format" 메뉴를 사용하여 USB 메모리 장치의 데이터를 지우십시오.

SETUP 메뉴

SETUP 메뉴에서는 리모콘을 사용하여 다양한 오디오/비디오 설정을 할 수 있고 기능을 조정할 수 있습니다.

메뉴/하위 메뉴	항목	기능	페이지
 General Setting	System		
	Screen Saver	화면 보호기를 설정/해제합니다.	30
	Disc Auto Playback	본 플레이어에서 디스크가 자동으로 재생되도록 설정합니다.	30
	HDMI Control	본 플레이어에서 TV/AV 리시버의 리모콘 제어 신호를 수신하도록 설정합니다.	30
	Network Control	이더넷을 통한 제어를 설정/해제합니다.	30
	Load Default	Security 설정을 제외한 모든 설정을 기본 설정으로 재설정합니다.	30
	Upgrade	본 플레이어를 업그레이드합니다.	30
	Easy Setup	언어, 해상도, 화면 비율을 설정합니다.	30
	Local Storage	Local Storage(30페이지)의 상태를 표시하고, Local Storage를 포맷하고, Local Storage에서 앞/뒤 USB 포트를 선택합니다.	30
	3D Playback Message	본 플레이어를 켜면 3D 비디오 재생에 관한 경고 메시지가 표시됩니다.	30
	Language		
	OSD	On Screen 표시 언어를 선택합니다.	31
	Menu	디스크 메뉴 언어에 우선 순위를 부여합니다.	31
	Audio	오디오 언어에 우선 순위를 부여합니다.	31
	Subtitle	자막 언어에 우선 순위를 부여합니다.	31
	Playback		
	Closed Caption	자막 방송을 설정/해제합니다.	31
	Angle Mark	앵글이 여러 개인 BD/DVD를 재생하는 경우 Angle Mark가 표시되도록 설정합니다.	31
	PIP Mark	Picture in Picture가 있는 BD/DVD를 재생하는 경우 PIP Mark가 표시되도록 설정합니다.	31
	Secondary Audio Mark	보조 오디오가 있는 BD/DVD를 재생하는 경우 Secondary Audio Mark가 표시되도록 설정합니다.	31
	DivX(R) VOD DRM	DivX(R) 비디오의 등록 코드를 표시합니다.	31
	DVD-Audio Mode	DVD-Audio 모드를 DVD-Audio/DVD-Video로 설정합니다.	31
	Security		
	Change Password	Parental Control 및 Country Code의 암호를 변경합니다.	31
	Parental Control	디스크 내용에 따라 Parental Control을 설정합니다.	31
	Country Code	Country Code를 설정합니다.	31
	Network		
	Internet Connection	인터넷 연결을 Enable/Disable로 설정합니다.	32
	Information	네트워크 정보 화면을 표시합니다.	32
	Connection Test	네트워크 연결 테스트를 수행합니다.	32
	IP Setting	IP 설정을 Auto/Manual로 설정합니다.	32
	BD-Live Connection	BD-Live 연결을 Permitted/Partial Permitted/Prohibited로 설정합니다.	32
	DLNA	DLNA를 Enable/Disable로 설정합니다.	32
Proxy Setting	프록시 설정을 합니다.	32	

메뉴/하위 메뉴	항목	기능	페이지	
 Display Setting	TV	3D Output	3D 또는 2D 비디오를 선택합니다.	32
		TV Screen	연결된 TV의 화면 비율을 설정하고, 비디오 출력을 조정합니다.	32
		Resolution	출력 비디오의 해상도를 선택합니다.	33
		TV System	TV System을 NTSC/PAL/Multi 중에서 선택합니다.	33
		Color Space	Color Space를 RGB/YCbCr 4:4:4/YCbCr 4:2:2/Full RGB 중에서 선택합니다.	33
		HDMI Deep Color	HDMI Deep Color를 30 bits/36 bits/Off 중에서 선택합니다.	33
		HDMI 1080p 24Hz	HDMI 1080p 24Hz를 Auto/Off로 설정합니다.	33
		Lip Sync	입모양과 목소리가 서로 동기화되지 않는 경우처럼 비디오와 오디오 사이의 지연을 조정합니다.	33
	Video Process	Video Mode	비디오 영상을 조정합니다.	33
		Color Adjust	각 색상의 Brightness/Saturation/Hue를 조정합니다.	33
		Auto Contrast	컨트라스트를 조정하여 재생되는 화상을 최적화합니다.	33
		Noise Reduction	Noise Reduction 레벨을 설정합니다.	33
		De-interlacing Mode	비디오 신호 감지 방법을 설정합니다.	34
		 Audio Setting	Audio Output	Coaxial/Optical
HDMI	HDMI 단자의 출력 모드를 Bitstream/PCM/Reencode/Off 중에서 선택합니다.			34
Downsampling	디지털 오디오 신호의 다운 샘플링 주파수를 48k/96k/192k 중에서 선택합니다.			34
DRC	DRC(Dynamic Range Compression)를 설정합니다.			34
SACD Output	SACD Priority		하이브리드 SA-CD를 재생하는 경우 컨텐츠를 선택합니다.	34
	HDMI Output		SA-CD를 재생하는 경우 HDMI 단자의 출력 모드를 DSD/PCM 중에서 선택합니다.	34
Speaker Setting	Configuration		7.1채널 서라운드 잭의 오디오 출력을 설정합니다.	34
	2ch Downmix		아날로그 2채널로 다운믹스하는 방법을 선택합니다.	34
Post Process	Up Mix		2채널 오디오 신호를 멀티 채널화합니다.	34
 System Information			소프트웨어 버전 및 MAC 주소(42페이지)를 표시합니다.	34

■ SETUP 메뉴 조작 예

본 플레이어에서 설정을 하려면 SETUP 메뉴 화면을 불러와야 합니다. 다음은 SETUP 메뉴의 기본 조작에 대한 설명입니다.



예: Parental Control 설정

참고

- 재생 도중에는 일부 항목을 설정할 수 없습니다. 이 경우, 설정하기 전에 ■를 두 번 눌러 재생을 완전히 중지하십시오.

1. SETUP 메뉴 화면을 표시합니다.

SETUP을 눌러 SETUP 메뉴 화면을 표시합니다. ◀/▶를 눌러 General Setting을 선택한 다음, ENTER 또는 ▼를 누릅니다.

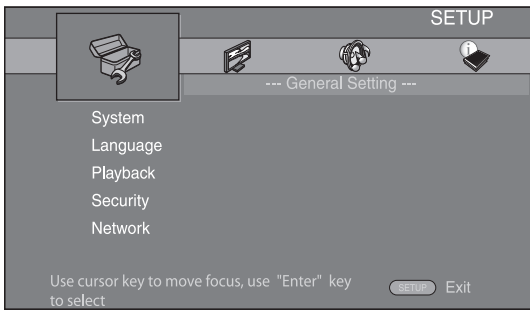

2. 하위 메뉴를 선택합니다.

▲/▼를 눌러 Security를 선택한 다음, ENTER 또는 커서 ▶를 누릅니다.

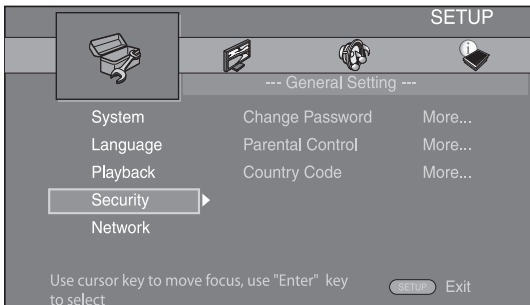

3. 메뉴 항목을 선택합니다.

▲/▼를 눌러 Parental Control을 선택한 다음, ENTER 또는 커서 ▶를 누릅니다.

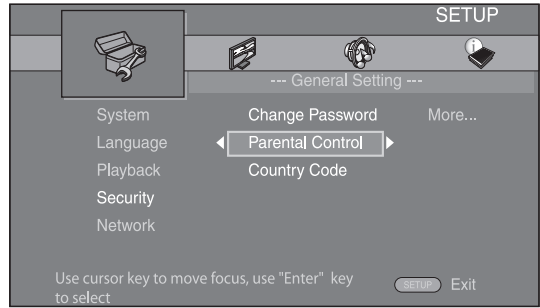

4. 암호를 입력합니다.

숫자 버튼으로 암호를 입력합니다.

- 기본 암호는 0000입니다.
- 올바른 암호를 입력해야 다음 설정 화면으로 이동할 수 있습니다.
- 암호를 변경하려면 "Change Password"(31페이지)를 참조하십시오.

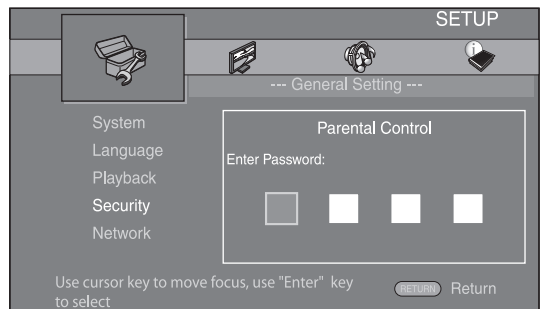

5. 다음 항목을 선택합니다.

▲/▼를 눌러 BD/DVD의 Parental Control 레벨을 선택한 다음, ENTER를 누릅니다.

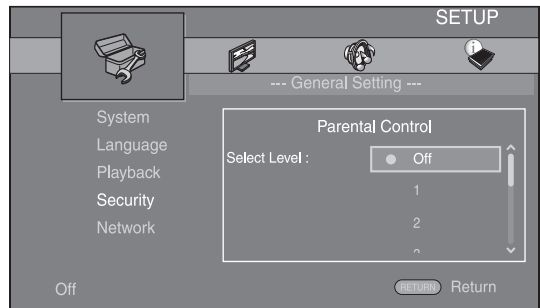

6. 메뉴 화면을 종료합니다.

◀를 누르면 이전 메뉴로 돌아갑니다.

■ General Setting

기본 설정에는 "*"가 표시되어 있습니다.

System

Screen Saver

화면 보호기를 On/Off로 설정할 수 있습니다. On으로 설정한 경우, 본 플레이어에서 3분 동안 아무런 조작도 하지 않으면 화면 보호기 모드로 전환됩니다. 그 이후에도 6분 동안 아무런 조작도 하지 않으면 본 플레이어가 대기 모드로 들어갑니다.

On*, Off

Disc Auto Playback

Disc Auto Playback을 On/Off로 설정할 수 있습니다. On으로 설정한 경우, 디스크를 넣으면 디스크가 자동으로 재생됩니다.

On*, Off

HDMI Control

플레이어가 HDMI 케이블(12페이지)을 통해 HDMI Control 기능과 호환되는 TV/AV 리시버의 제어 신호를 수신하도록 설정할 수 있습니다.

On, Off*

HDMI Control 기능 사용

HDMI Control 기능을 사용하면 본 플레이어와 TV(HDMI Control 기능 지원)를 대화 형식으로 조작할 수 있습니다.

HDMI 케이블을 사용하여 본 플레이어를 HDMI Control 기능과 호환되는 TV에 연결하고 SETUP 메뉴의 HDMI Control을 On으로 설정하면(30페이지) 다음과 같은 기능을 수행할 수 있습니다.

- 자동 입력 선택 기능
본 플레이어에서 재생을 시작하면, TV(및 본 플레이어가 AV 리시버를 통해 TV에 연결된 경우에는 AV 리시버)의 입력 셀렉터가 본 플레이어에 자동으로 전환됩니다. TV에 따라 TV가 자동으로 켜집니다.
- 자동 전원 꺼짐 기능
본 플레이어가 정지 모드에 있고 SETUP 메뉴 화면이 표시되지 않은 상태에서 TV를 끄면 본 플레이어도 자동으로 꺼집니다.

참고

- TV에 따라 HDMI Control 기능이 올바르게 작동하지 않을 수 있습니다.
- TV 또는 AV 리시버에 따라 위에 표시되지 않은 다른 기능이 작동될 수도 있습니다.
- HDMI Control 기능을 사용하려면, 모든 컴포넌트(본 플레이어, TV 및 AV 리시버)에서 HDMI Control 기능을 설정해야 합니다. 특정 조작이 필요할 수도 있습니다.
- TV에 따라 각 기능의 활성화/비활성을 별도로 설정하기도 합니다.
- 설정과 관련된 자세한 내용은 TV 및/또는 AV 리시버에 부속된 사용 설명서를 참조하십시오.
- On으로 설정하면 HDMI 제어 기능으로 인해 대기 모드 동안 전력 소모가 증가합니다.

Network Control

이더넷을 통한 제어를 On/Off로 설정할 수 있습니다. 본 플레이어는 YNC(Yamaha Network Control) 프로토콜을 채택하였습니다.

On, Off*

참고

- On으로 설정하면 네트워크 제어 기능으로 인해 대기 모드 동안 전력 소모가 늘어납니다.
- On으로 설정하면 시스템 시작 시간이 단축됩니다.

Load Default

Security 설정(31페이지)을 제외한 본 플레이어의 모든 설정을 기본 설정으로 재설정할 수 있습니다. 기본 설정에 대한 자세한 내용은 27-34페이지를 참조하십시오.

Upgrade

디스크, USB 저장 장치 또는 네트워크에서 소프트웨어를 수동으로 업그레이드할 수 있습니다. 소프트웨어 업그레이드에 대한 자세한 내용은 "소프트웨어 업그레이드"(37페이지)를 참조하십시오.

Easy Setup

Easy Setup(18페이지)을 수행할 수 있습니다.

Local Storage

Local Storage 정보를 표시하고, Local Storage를 포맷하고, Front USB/Rear USB를 선택하여 BD-Live 데이터를 저장할 수 있습니다.

USB 메모리 장치에서 "BUDA" 폴더를 포맷하려면(비우려면), Information을 선택하고 화면에 "Format" 표시되면 **ENTER**를 누릅니다.

Front USB, Rear USB*

힌트

- Local Storage는 Blu-ray 디스크를 재생하는 경우 보조 메모리로 사용됩니다.

3D Playback Message

본 플레이어를 켜면 TV에 표시되는 3D 비디오 재생에 관한 경고 메시지를 켜거나 끌 수 있습니다.

On*, Off

Language

OSD

SETUP 메뉴와 같이 화면에 표시되는 메시지 또는 메뉴 인 On Screen 표시 언어를 선택할 수 있습니다.

English*, Français, Español, Deutsch, Italiano, Svenska, Nederlandse, Русский

참고

- 러시아 모델의 경우 기본 설정은 **Русский**입니다.

Menu

디스크 메뉴 언어에 우선 순위를 부여할 수 있습니다.

English*, Français, 中文, Español, Deutsch, Italiano, Nederlandse, Portuguese, Danish, Svenska, Finnish, Norwegian, Русский, Korean, Japanese, More

참고

- 러시아 모델의 경우 기본 설정은 **Русский**입니다.
- 한국 모델의 경우 기본 설정은 **Korean**입니다.

Audio

BD/DVD 재생 시 오디오 언어에 우선 순위를 부여할 수 있습니다. 설정 항목에 대한 자세한 내용은 "Menu"(31 페이지)를 참조하십시오.

Subtitle

Subtitle 언어에 우선 순위를 부여할 수 있습니다.

English, Français, 中文, Español, Deutsch, Italiano, Nederlandse, Portuguese, Danish, Svenska, Finnish, Norwegian, Русский, Korean, Japanese, More, Off*

참고

- 러시아 모델의 경우 기본 설정은 **Русский**입니다.
- 한국 모델의 경우 기본 설정은 **Korean**입니다.

Playback

Closed Caption

자막 방송이 있는 BD/DVD를 재생하는 경우 자막 방송 (41페이지)이 표시되도록 설정할 수 있습니다.

On, Off*

Angle Mark

앵글이 여러 개인 BD/DVD를 재생하는 경우 Angle Mark()가 표시되도록 설정할 수 있습니다.

On*, Off

PIP Mark

Picture in Picture(26페이지)가 있는 BD를 재생하는 경우 PIP Mark()가 표시되도록 설정할 수 있습니다.

On*, Off

Secondary Audio Mark

보조 오디오가 있는 BD를 재생하는 경우 Secondary Audio Mark()가 표시되도록 설정할 수 있습니다.

On*, Off

DivX(R) VOD DRM

DivX(R) 비디오의 등록 코드를 표시할 수 있습니다.

DVD-Audio Mode

일부 DVD-Audio 디스크에는 DVD-Audio 콘텐츠 이외에 DVD-Video 콘텐츠도 포함되어 있습니다. DVD-Audio 모드 또는 DVD-Video 모드를 선택할 수 있습니다.

DVD-AUDIO* DVD-Audio/Video 콘텐츠 모두 재생됩니다. 디스크에 따라 DVD-Audio 콘텐츠만 재생되기도 합니다.

DVD-VIDEO DVD-Video 콘텐츠만 재생됩니다.

참고

- 이 설정은 디스크를 넣지 않은 경우에만 사용할 수 있습니다.

Security

Change Password

Parental Control 레벨 및 Country Code를 변경하기 위한 암호를 설정할 수 있습니다. "Parental Control"(31페이지) 및 "Country Code"(31페이지)를 참조하십시오.

참고

- 기본 비밀번호는 0000입니다.
- 비밀번호를 잊은 경우, "문제 해결" (38페이지)를 참조하여 모든 Security 설정값을 기본값으로 설정하십시오.

Parental Control

일부 BD/DVD 디스크의 경우, 시청자 나이에 따라 디스크를 볼 수 있는 시청 연령 제한이 설정됩니다. 디스크 콘텐츠에 따라 화면에 표시된 Parental Control을 설정할 수 있습니다.

Parental Control 레벨을 설정하려면 먼저 암호(31페이지)의 "Change Password" 참조)를 입력해야 합니다. Parental Control을 설정한 다음, 현재의 Parental Control 레벨보다 높은 레벨의 디스크를 재생하거나 Parental Control 레벨을 변경하려면 암호를 입력하려는 대화 상자가 나타납니다.

Off*, 1에서 8

Country Code

거주하고 있는 Country Code를 설정할 수 있습니다. Country Code를 설정하려면 먼저 암호(31페이지)의 "Change Password" 참조)를 입력해야 합니다. Parental Control 등급 지정 및 디스크 재생 시에도 이 설정이 사용될 수 있습니다.

Network

Internet Connection

네트워크에서 BD-Live(26페이지), DLNA(21페이지) 및 소프트웨어 업그레이드를 사용하는 경우 이 항목을 Enable로 설정합니다(37페이지).

Enable*, **Disable**

Information

네트워크 정보 화면을 표시할 수 있습니다. 이 화면에서 인터페이스(이더넷), 주소 유형, IP 주소, 서브넷 마스크, 기본 게이트웨이 및 DNS 정보를 볼 수 있습니다.

Connection Test

인터넷 연결 테스트를 실행할 수 있습니다. 테스트가 실패하면 "IP Setting"(32페이지)을 확인하고 테스트를 다시 실행하십시오.

IP Setting

다음과 같이 네트워크 설정을 구성할 수 있습니다.

- Auto*** 이 기능을 선택하면 본 플레이어와 DHCP 서버의 네트워크 설정을 자동으로 구성합니다.
- Manual** 이 기능을 선택하면 네트워크 설정(IP Address, Subnet Mask, Default Gateway, DNS)을 수동으로 구성할 수 있습니다.

힌트

- **Numeric keys** 문자를 입력합니다.
- **◀▶** 강조표시를 이동합니다.
- **CLEAR** 문자를 지웁니다.
- **ENTER** 설정 내용을 저장한 후 메뉴를 종료합니다.

BD-Live Connection

BD-Live 콘텐츠에 대한 액세스 제한을 설정할 수 있습니다.

- Permitted** 모든 BD-Live 디스크를 네트워크에 연결할 수 있습니다.
- Partial Permitted*** 소비자 인증이 있는 디스크만 연결할 수 있습니다.
- Prohibited** 모든 BD-Live 디스크의 네트워크 연결이 금지됩니다.

DLNA

DLNA(21페이지)를 Enable/Disable로 설정할 수 있습니다. DLNA 기능을 사용하지 않으면 Disable로 설정하십시오.

Enable*, **Disable**

Proxy Setting

Proxy Setting을 설정할 수 있습니다. 일반적인 사용 시 Disable로 설정하십시오. 프록시 설정을 하려면 Enable로 설정하십시오.

- Enable** 프록시 호스트 및 프록시 포트 설정을 설정합니다.
- Disable*** 프록시 서버를 비활성화합니다. 프록시 서버를 사용하지 않는 경우 이 항목을 선택합니다.
- Proxy Host** 프록시 호스트를 설정합니다.
- Proxy Port** 프록시 포트를 설정합니다.

Display Setting

기본 설정에는 "*"가 표시됩니다.

TV

3D Output

다음과 같이 본 플레이어의 3D 또는 2D 비디오 출력을 선택할 수 있습니다.

- Auto*** 본 플레이어가 3D 또는 2D 비디오를 자동으로 선택합니다.
- Off** 본 플레이어가 항상 2D 비디오를 선택합니다.

참고

- "3D Output"을 "Auto"로 선택한 후 Blu-ray 3D 디스크를 재생한다 하더라도 TV와 기타 연결 및 설정(12페이지)에 따라 본 플레이어는 2D 화상을 선택할 수도 있습니다.



TV Screen

연결된 TV의 화면 비율을 설정하고, 비디오 출력을 조정할 수 있습니다.

TV를 바꾸거나(예를 들면, 새로 구입) 연결된 TV의 화면 비율을 변경하면 TV Screen 설정을 변경해야 합니다.

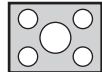
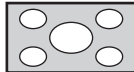
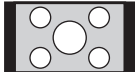
- 16:9 Full** 화면 비율이 16:9인 TV에 본 플레이어가 연결된 경우 선택합니다. 화면 비율이 4:3인 비디오를 재생하면 비디오가 아래와 같이 표시됩니다.
- 16:9 Normal*** 화면 비율이 16:9인 TV에 본 플레이어가 연결된 경우 선택합니다. 화면 비율이 4:3인 비디오를 재생하면 비디오가 아래와 같이 표시됩니다.
- 4:3 Pan Scan** 화면 비율이 4:3인 TV에 본 플레이어가 연결된 경우 선택합니다. 화면 비율이 16:9인 비디오를 재생하면 비디오가 아래와 같이 표시됩니다.
- 4:3 Letterbox** 화면 비율이 4:3인 TV에 본 플레이어가 연결된 경우 선택합니다. 화면 비율이 16:9인 비디오를 재생하면 비디오가 아래와 같이 표시됩니다.

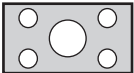
원래 화상 사이즈	16:9(와이드 스크린) TV의 경우	
	16:9 Full	16:9 Normal
 4:3		

원래 화상 사이즈	4:3 TV의 경우	
	4:3 Pan Scan	4:3 Letterbox
 16:9		

Resolution

비디오 출력 해상도를 Auto, 480i/576i, 480p/576p, 720p, 1080i 및 1080p 중에서 선택할 수 있습니다. Auto로 설정하면, 연결된 TV에 따라 해상도가 최대 해상도로 설정됩니다. 출력 형식에 대한 자세한 내용은 "비디오 출력 형식에 대하여"(36페이지)를 참조하십시오.

Auto*, 480i/576i, 480p/576p, 720p, 1080i, 1080p

참고

- HDMI 단자에서 HD 오디오(예: Dolby TrueHD 또는 DTS-HD Master Audio)를 출력하려면 Resolution을 Auto 또는 720p 이상으로 설정하십시오.

TV System

TV System을 PAL, NTSC 및 Multi 중에서 선택할 수 있습니다. TV 세트와 동일한 TV System을 설정하십시오. 출력 형식에 대한 자세한 내용은 "비디오 출력 형식에 대하여"(36페이지)를 참조하십시오.

NTSC, PAL*, Multi (호주, 아시아, 영국, 유럽 및 러시아 모델)

NTSC*, PAL, Multi (미국, 캐나다, 중남미, 대만 및 한국 모델)

Color Space

HDMI에서 출력되는 Color Space(41페이지)를 선택할 수 있습니다. 이 기능은 본 플레이어가 HDMI 케이블을 사용하여 연결된 경우에만 사용할 수 있습니다.

RGB 일반 신호 범위에서 비디오 신호를 출력합니다.

YCbCr 4:4:4* Color Space를 YCbCr 4:4:4로 설정합니다.

YCbCr 4:2:2 Color Space를 YCbCr 4:2:2로 설정합니다.

Full RGB RGB를 설정했지만 화면에 흰색과 검은색이 너무 약할 경우 이 항목을 선택합니다. 이 설정은 연결된 컴포넌트가 RGB 0-255 범위를 지원하는 경우 효과적입니다.

참고

- 이 기능을 지원하는 TV에서만 이 기능을 사용할 수 있습니다.

HDMI Deep Color

TV 및/또는 AV 리시버가 Deep Color(41페이지)와 호환되는 경우, TV/AV 리시버에 맞게 이 항목을 설정하십시오. 이 기능은 본 플레이어가 HDMI 케이블을 사용하여 연결된 경우 사용할 수 있습니다.

30 bits, 36 bits, Off*

HDMI 1080p 24Hz

이 기능은 프레임 속도가 24Hz로 인코딩된 BD-Video를 HDMI 1080p 24Hz로 출력합니다. 이 기능을 사용하면 비디오가 더 매끄럽게 재생될 수 있습니다. 이 기능은 TV/AV 리시버가 이 기능을 지원하고, 본 플레이어가 HDMI 케이블을 사용하여 연결된 경우 사용할 수 있습니다. 출력 형식에 대한 자세한 내용은 "비디오 출력 형식에 대하여"(36페이지)를 참조하십시오.

Auto*, Off

참고

- 출력 해상도가 1080p가 아닌 경우 이 설정은 사용할 수 없습니다.

Lip Sync

다음과 같이 Lip Sync(42페이지) 기능을 설정/조정할 수 있습니다.

Auto* 본 플레이어가 Lip Sync 기능을 자동으로 조정합니다.

Manual Lip Sync 기능을 수동으로 조정할 수 있습니다. 2D 및 3D 콘텐츠의 오디오 지연을 개별적으로 설정할 수 있습니다.

2D

3D

Off 본 플레이어가 Lip Sync 기능을 조정하지 않습니다.

Video Process

Video Mode

다음과 같은 Video Mode를 선택할 수 있습니다.

Standard* 화상이 가장 자연스럽게 균형이 잘 맞습니다. 이 모드는 일반적인 사용에 적합합니다.

Vivid 화상이 훨씬 생생하고 선명합니다.

Cinema 어두운 실내에서 동영상을 시청할 때 적합합니다.

Custom 화상을 수동으로 조정할 수 있습니다. ▲/▼를 눌러 파라미터를 선택한 다음, ◀/▶를 눌러 값을 조정합니다.

Brightness

화상의 전반적인 밝기를 조정합니다.

Saturation

영사된 화상의 색상 포화도를 조정합니다.

Hue

영사된 화상의 색조를 조정합니다.

Contrast

화상에서 밝은 영역(흰색 레벨)을 조정합니다.

Sharpness

비디오에서 물체의 선명도를 조정합니다.

CTI

컬러 영상의 가장자리를 매끄럽게 합니다. 컬러 영상이 더 뚜렷해집니다.

기본 설정은 0입니다.

Color Adjust

각 색상(Red/Green/Blue/Yellow/Cyan/Magenta)에 대해 Brightness/Saturation/Hue를 조정할 수 있습니다. 이 기능을 사용하려면 Video Mode를 Custom으로 설정하십시오. 설정 항목에 대한 자세한 내용은 "Video Mode"(33페이지)를 참조하십시오.

기본 설정은 0입니다.

Auto Contrast

명암 대비를 조정하여 재생되는 화상을 최적화합니다. 이 기능을 사용하려면 Video Mode를 Custom으로 설정하십시오.

Off*, On

Noise Reduction

Noise Reduction을 레벨 0에서 3으로 설정할 수 있습니다. 0은 설정 해제이고, 3은 최대 레벨입니다.

0*, 1, 2, 3

De-interlacing Mode

비디오 신호 감지 방법을 선택할 수 있습니다. 일반적인 사용에서는 Auto로 설정하십시오. 화면에 가로 줄무늬가 나타나는 경우, 노이즈를 제거하려면 Film/Video로 설정하십시오.

Auto*, Film, Video

Audio Setting

기본 설정에는 "*"가 표시됩니다.

Audio Output

Coaxial/Optical

COAXIAL 잭 및 OPTICAL 단자의 출력 모드를 선택할 수 있습니다. 출력 형식에 대한 자세한 내용은 "오디오 출력 형식에 대하여"(35페이지)를 참조하십시오.

Bitstream 디지털 신호를 전혀 처리하지 않고 출력합니다. 보조 오디오는 출력되지 않습니다.

PCM 2채널 PCM을 출력합니다.

Reencode* 보조 오디오와 함께 Bitstream을 출력합니다.

Off 음을 소거합니다.

HDMI

HDMI 단자의 출력 모드를 선택할 수 있습니다. 설정 항목에 대한 자세한 내용은 "Coaxial/Optical"(34페이지)을 참조하십시오. 출력 형식에 대한 자세한 내용은 "오디오 출력 형식에 대하여"(35페이지)를 참조하십시오.

Bitstream*, PCM, Reencode, Off

참고

- HDMI 단자에서 HD 오디오(예: Dolby TrueHD 또는 DTS-HD Master Audio)를 출력하려면 Resolution을 Auto 또는 720p(33페이지) 이상으로 설정하십시오.

Downsampling

디지털 오디오 신호 다운샘플링 주파수를 선택할 수 있습니다. 이 기능은 COAXIAL 잭/OPTICAL 단자에서 오디오 신호 출력 시 효과적입니다.

48k* 디지털 PCM 출력의 최고 샘플링 속도가 48 kHz입니다.

96k 디지털 PCM 출력의 최고 샘플링 속도가 96 kHz입니다.

192k 디지털 PCM 출력의 최고 샘플링 속도가 192 kHz입니다.

DRC

DRC(Dynamic Range Compression)(41페이지)를 On/Off/Auto로 설정할 수 있습니다. Auto로 설정하면, Dolby TrueHD 형식으로 된 DRC 정보가 포함된 소스의 경우 DRC가 자동으로 켜집니다. DRC는 폭발음과 같은 강한 사운드는 작게, 대화는 잘 들리도록 합니다. 밤에 영화를 볼 때 유용합니다.

Off*, On, Auto

SACD Output

SACD Priority

멀티 채널 또는 스테레오(2채널) 콘텐츠가 모두 포함된 하이브리드 SA-CD(4페이지)를 넣은 경우 둘 중에서 재생되는 콘텐츠를 선택할 수 있습니다.

Multi-ch*, 2-ch

HDMI Output

SA-CD를 재생하는 경우 HDMI 단자에서 출력되는 오디오 신호를 선택할 수 있습니다.

DSD* DSD raw 신호를 출력합니다. 본 플레이어가 DSD 호환 AV 리시버에 연결된 경우 이 항목을 사용하는 것이 좋습니다.

PCM 본 플레이어에서 디코딩된 PCM 신호를 출력합니다.

Speaker Setting

Configuration

연결된 스피커 또는 앰프에 따라 7.1채널 서라운드 출력을 설정할 수 있습니다.

1 ▲/▼를 눌러 구성하려는 스피커를 선택한 다음, ENTER를 누릅니다.

2 아래와 같은 값을 조정합니다. 선택한 스피커에 따라 일부 항목이 표시되지 않을 수 있습니다.

Size 스피커의 우퍼 색선이 16 cm 이상일 경우 Large를 선택합니다. 16 cm보다 작으면 Small을 선택합니다.

Large*, Small

Trim -12에서 0 dB(0.5 dB 간격)

기본 설정은 0 dB입니다.

Delay 0.5에서 10 m(0.5 m 간격)

기본 설정은 3 m입니다.

Disable 선택한 스피커를 사용하지 않을 경우 Yes를 선택합니다.

Yes, No*

3 RETURN을 눌러 스피커 선택으로 돌아옵니다.

2ch Downmix

아날로그 2채널로 다운믹스하는 방법을 Stereo 또는 Lt/Rt 중에서 선택할 수 있습니다.

Stereo* 채널 출력이 스테레오로 변경되어, 두 개의 프론트 스피커의 사운드만 전달됩니다.

Lt/Rt 본 기기가 Dolby Pro Logic 디코더에 연결된 경우 이 항목을 선택합니다. 리어 스피커의 사운드가 2 채널 스테레오 사운드로 믹스됩니다.

Post Process

Up Mix

2채널 오디오 신호를 멀티 채널화할 수 있습니다. 멀티 채널화하려면 NEO6를 선택한 다음 Cinema 또는 Music 모드를 선택합니다.

Off*, NEO6

System Information

소프트웨어 버전 및 MAC 주소(42페이지)가 표시됩니다.

■ 오디오 출력 형식에 대하여

소스 형식	HDMI			COAXIAL/OPTICAL			MIXED 2CH/7.1 채널 서라운드	
	Bitstream	PCM	Reencode	Bitstream	PCM	Reencode		
PCM 2채널	PCM 2채널			PCM 2채널			2채널	
PCM 5.1채널	PCM 5.1채널			PCM 2채널			2채널/5.1채널	
PCM 7.1채널	PCM 7.1채널			PCM 2채널			2채널/7.1채널	
Dolby Digital	SA* 또는 BCS** 사용	Dolby Digital	PCM 최대 5.1채널	Dolby Digital	Dolby Digital	PCM 2ch	Dolby Digital	2채널/5.1채널
				Dolby Digital				
Dolby Digital Plus	SA* 또는 BCS** 사용	Dolby Digital Plus	PCM 최대 7.1채널	Dolby Digital Plus	Dolby Digital	PCM 2ch	Dolby Digital	2채널/7.1채널
				Dolby Digital				
Dolby TrueHD	SA* 또는 BCS** 사용	Dolby TrueHD	PCM 최대 7.1채널	Dolby TrueHD	Dolby Digital	PCM 2ch	Dolby Digital	2채널/7.1채널
				Dolby Digital				
DTS	SA* 또는 BCS** 사용	DTS	PCM 최대 5.1채널	DTS	DTS	PCM 2ch	DTS	2채널/5.1채널
				DTS				
DTS HD High Resolution	SA* 또는 BCS** 사용	DTS HD High Resolution	PCM 최대 7.1채널	DTS HD High Resolution	DTS	PCM 2ch	DTS	2채널/7.1채널
				DTS				
DTS-HD Master Audio	SA* 또는 BCS** 사용	DTS-HD Master Audio	PCM 최대 7.1채널	DTS-HD Master Audio	DTS	PCM 2ch	DTS	2채널/7.1채널
				DTS				

* "SA"는 보조 오디오(Secondary Audio)입니다.
 ** "BCS"는 버튼 조작음, 팝업 메뉴 효과음 등입니다.

SA-CD 출력 형식

SACD Output 설정		HDMI	COAXIAL/OPTICAL	MIXED 2CH/7.1채널 서라운드
SACD Priority	HDMI Output			
Multi-ch	DSD	DSD 최대 5.1채널	출력 안됨	2채널/5.1채널
	PCM	PCM 최대 5.1채널	출력 안됨	2채널/5.1채널
2-ch	DSD	DSD 2채널	출력 안됨	2채널/2채널
	PCM	PCM 2채널	출력 안됨	2채널/2채널

참고

- Coaxial/Optical 또는 HDMI가 Bitstream으로 설정된 경우 보조 오디오가 출력되지 않습니다. (34페이지)
- HDMI 단자에서 HD 오디오(예: Dolby TrueHD 또는 DTS-HD Master Audio)를 출력하려면 Resolution을 Auto 또는 720p(33페이지) 이상으로 설정하십시오.
- SA-CD를 재생하는 경우, Speaker Setting(34페이지)의 Configuration은 HDMI Output이 PCM으로 설정된 경우에만 적용됩니다.

■ 비디오 출력 형식에 대하여

TV System이 NTSC로 설정된 경우

	Resolution	Auto	480i/576i	480p/576p	720p	1080i	1080p	
							24Hz	기타
HDMI	BD 재생	최대	최대	최대	720p 60 Hz	1080i 60 Hz	1080p 24 Hz	1080p 60 Hz
	기타						1080p 60 Hz	
COMPONENT	상용 DVD 재생	480i	480i	480p	480p	480p	480p	
	BD 재생			480i	480i	480i	끔	480i
	기타			480p	720p 60 Hz *	1080i 60 Hz *	1080i 60 Hz *	
VIDEO	BD 재생	480i	480i	480i	480i	480i	끔	480i
	기타						480i	

* 디스크나 콘텐츠에 따라 본 플레이어는 480p 비디오 신호를 출력합니다.

TV System이 PAL로 설정된 경우

	Resolution	Auto	480i/576i	480p/576p	720p	1080i	1080p	
							24Hz	기타
HDMI	BD 재생	최대	최대	최대	720p 50 Hz	1080i 50 Hz	1080p 24 Hz	1080p 50 Hz
	기타						1080p 50 Hz	
COMPONENT	상용 DVD 재생	576i	576i	576p	576p	576p	576p	
	BD 재생			576i	576i	576i	끔	576i
	기타			576p	720p 50 Hz *	1080i 50 Hz *	1080i 50 Hz *	
VIDEO	BD 재생	576i	576i	576i	576i	576i	끔	576i
	기타						576i	

* 디스크나 콘텐츠에 따라 본 플레이어는 576p 비디오 신호를 출력합니다.

TV System이 Multi로 설정된 경우

TV System 이 Multi 로 설정된 경우 , 비디오 신호는 소스와 동일한 주파수로 출력됩니다 . TV 의 주파수 설정 및 출력 비디오 신호의 해상도에 대한 자세한 내용은 위의 표를 참조하십시오 .
 SETUP 메뉴와 같은 메뉴 화면이 표시된 경우 비디오 신호는 소스와 동일한 주파수로 출력됩니다 .

참고

- 표에서 "최대"는 연결된 TV에서 지원되는 최대 해상도로 설정된다는 것을 의미합니다.
- 출력 해상도가 1080p가 아니면 HDMI 1080p 24Hz 설정을 사용할 수 없습니다.
- 본 플레이어가 HDMI로부터 1080p 24Hz 비디오 신호를 출력하는 경우 COMPONENT와 VIDEO 쪽에서는 신호가 출력되지 않습니다.
- 상업적으로 출시된 DVD를 컴포넌트 출력에서 재생하는 경우 최대 해상도는 480p/576p입니다.
- TV System이 NTSC로 설정된 경우 비디오 소스가 60 Hz가 아니면 비디오 출력 신호가 60 Hz로 변환됩니다.
- TV System이 PAL로 설정된 경우 비디오 소스가 50 Hz가 아니면 비디오 출력 신호가 50 Hz로 변환됩니다.

소프트웨어 업그레이드

본 플레이어 소프트웨어를 최신으로 업그레이드하지 않은 경우 새로 출시된 BD 디스크가 재생되지 않을 수 있습니다. 본 플레이어가 최신 소프트웨어에서 작동되도록 소프트웨어 업그레이드로 플레이어를 업그레이드하는 것이 좋습니다.

소프트웨어 업그레이드 기능을 확인하려면 다음을 방문하십시오.

<http://download.yamaha.com/downloads/service/top/?site=europe.yamaha.com&language=en>

힌트

- 업그레이드 파일 패키지가 포함된 디스크를 넣으면 소프트웨어 업그레이드가 자동으로 시작됩니다.

참고

- 소프트웨어 업그레이드를 실행 중일 때는 디스크/USB 메모리 장치를 빼거나, 본 플레이어를 대기 모드로 설정하거나, 전원 케이블/LAN 케이블을 뽑지 마십시오.

■ 소프트웨어 업그레이드

1. 소프트웨어 업그레이드를 준비합니다.

디스크/USB 저장 장치에서 소프트웨어를 업그레이드하는 경우:

- ① 업그레이드 파일 패키지를 디스크/USB 메모리 장치의 적절한 폴더에 저장합니다. 자세한 내용은 업그레이드 파일 패키지에 부착된 설명서를 참조하십시오.
- ② 디스크를 넣거나 USB 메모리 장치를 연결합니다.
디스크를 넣으면 소프트웨어 업그레이드가 자동으로 시작됩니다. 단계 2를 건너뛸니다.

네트워크에서 소프트웨어를 업그레이드하는 경우:
본 플레이어가 네트워크에 연결되어 있는지 확인하십시오.

2. 업그레이드 방법을 선택하고 SETUP 메뉴에서 업그레이드를 시작합니다.

- ① **SETUP**을 눌러 SETUP 메뉴 화면을 표시합니다.
- ② General Setting → System → Upgrade를 선택합니다.

- ③ Disc/USB Storage/Network 중에서 업그레이드 파일 패키지가 포함된 항목을 선택합니다.

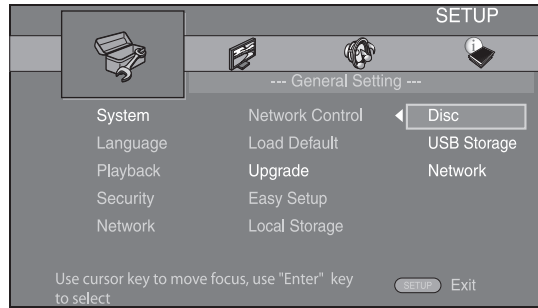

3. 시스템에서 업그레이드 파일 패키지를 검색합니다.

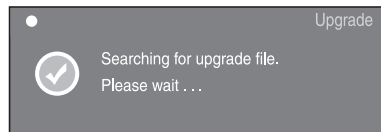

4. ENTER를 눌러 업그레이드를 시작합니다.

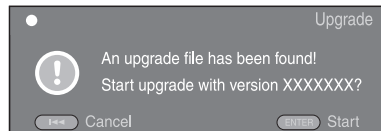

5. 업그레이드가 완료되었습니다. 시스템이 다시 시작됩니다.

문제 해결

본 플레이어가 정상적으로 작동하지 않을 경우 아래 표를 참조하십시오. 아래에 해당되지 않는 문제가 발생한 경우 또는 아래의 해결책이 도움이 안 되는 경우 본 플레이어를 끄고 전원 케이블을 분리한 다음 가까운 공인 Yamaha 대리점이나 서비스 센터로 문의하십시오.

■ 전원

문제	원인 및 해결 방법
전원이 켜지지 않는다.	<ul style="list-style-type: none"> - AC 전원 케이블을 올바르게 연결하십시오. - 앞면 패널의 ⏻를 눌러 전원을 켜십시오.
플레이어가 꺼진다.	<ul style="list-style-type: none"> - 10분 동안 계속해서 아무 작동도 하지 않으면(재생 안함) 전원이 자동으로 꺼집니다.

■ 기본 조작

문제	원인 및 해결 방법
리모콘이 작동하지 않는다.	<ul style="list-style-type: none"> - 리모콘 작동 범위 내에서 리모콘을 사용하십시오. (5페이지) - 배터리를 교체하십시오. (5페이지) - 본체 및 리모콘의 ID 설정을 확인하십시오. (9페이지)
버튼이 작동하지 않는다.	<ul style="list-style-type: none"> - 앞면 패널의 ⏻를 5초 정도 눌러 본 플레이어를 다시 시작하십시오. - 본 플레이어를 완전히 재설정하려면, AC 콘센트에서 전원 케이블을 10초 이상 동안 뽑아 놓은 후에, 전원 케이블을 AC 콘센트에 다시 꽂은 다음 본 플레이어를 켜십시오.
암호를 잊어버렸다.	<ul style="list-style-type: none"> - 플레이어에 디스크가 들어 있지 않고 재생이 정지된 상태에서 앞면 패널의 ■ 및 ■를 동시에 눌러 플레이어를 기본 설정으로 설정하십시오(Security 설정(31페이지)도 재설정됨). 전원이 자동으로 꺼진 후에 ⏻를 눌러 전원을 다시 켜십시오.

■ 디스크 재생

문제	원인 및 해결 방법
플레이어에서 디스크를 재생할 수 없다.	<ul style="list-style-type: none"> - 디스크를 꺼내 청소하여 주십시오. (4페이지) - 디스크가 올바르게 들어 있는지 확인하십시오(라벨 면이 위로 되어 있고 디스크 트레이의 제자리에 들어 있는지 확인). (4페이지) - 본 플레이어에서 지원하는 디스크를 사용하십시오. (3페이지) - 디스크를 꺼낸 다음 본 플레이어에서 지원하는 디스크인지 확인하십시오. (3페이지) - 지역 코드를 확인하십시오. (3페이지) - 다른 디스크를 넣어서 디스크가 손상되었는지 확인하십시오. - CD-R/RW, DVD+R/RW/R DL 및 DVD-R/RW/R DL은 파이널라이즈해야 합니다. (3페이지)
비디오가 멈춘다.	<ul style="list-style-type: none"> - 강한 충격 또는 진동이 감지된 경우 플레이어가 정지됩니다.
재생을 시작하거나 디스크를 읽어들이 때 플레이어에서 딱 하는 소리가 들린다.	<ul style="list-style-type: none"> - 이 소리는 플레이어 고장이 아니며 정상적인 작동 상태입니다.

■ 사진

문제	원인 및 해결 방법
사진이 표시되지 않는다.	<ul style="list-style-type: none"> - 케이블이 올바르게 연결되어 있는지 확인하십시오. (10페이지) - 연결된 TV 또는 AV 리시버가 올바른 입력으로 설정되어 있는지 확인하십시오. (10페이지) - 부속된 비디오 핀 케이블을 사용하여 본 플레이어를 VIDEO 잭(13페이지)이 장착된 TV에 연결하고 Resolution을 올바르게 설정하십시오. (33페이지) - TV System이 올바르게 설정되어 있지 않습니다. 리모콘의 DIMMER를 잠시 눌러 TV System 설정을 기본 설정으로 재설정하십시오.
화면이 정지되고 조작 버튼이 작동하지 않는다.	<ul style="list-style-type: none"> - ■를 누른 다음 재생을 다시 시작하십시오. - 전원을 껐다가 다시 켜십시오. - 앞면 패널의 ⏻를 5초 정도 눌러 본 플레이어를 다시 시작하십시오.
비디오가 원하는 해상도로 출력되지 않는다.	<ul style="list-style-type: none"> - 원하는 해상도로 설정하십시오. (33페이지)
와이드 스크린 비디오가 세로로 늘어난 것처럼 보이거나, 화면 위아래에 검은색 띠가 나타난다. 또는 4:3 비디오가 가로로 늘어난 것처럼 보인다.	<ul style="list-style-type: none"> - TV의 화면 비율을 변경하십시오. (32페이지)
네모난 무늬(모자이크)가 화면에 나타난다.	<ul style="list-style-type: none"> - 디지털 화상 압축 기술의 특성상 빠른 동작이 있는 장면에서 화상에 블록이 보일 수 있습니다.
DVD 비디오를 VCR로 녹화하거나 VCR을 통해 재생하면 재생 화면이 고르지 못하다.	<ul style="list-style-type: none"> - 본 플레이어는 아날로그 복사 방지 규정을 준수합니다. 일부 디스크에는 복사 방지 신호가 포함되어 있습니다. 이러한 디스크를 VCR을 통해 재생하려고 하거나 VCR에 녹화하고 신호를 재생하려고 하면 복사 방지로 인해 올바르게 재생되지 않습니다.
오디오가 출력되지 않거나 화상이 올바르게 재생되지 않는다.	<ul style="list-style-type: none"> - 복사 방지 콘텐츠가 녹화된 일부 디스크의 경우 오디오가 출력되지 않거나 화상이 올바르게 재생되지 않을 수 있습니다.

■ 사운드

문제	문제 및 해결 방법
사운드가 출력되지 않거나 왜곡된다.	<ul style="list-style-type: none"> - 오디오 케이블이 올바르게 연결되어 있는지 확인하십시오. (10페이지) - 정지화상 모드, 슬로 모션 재생, 빨리감기 및 빨리되감기 도중에는 사운드가 출력되지 않습니다. (7페이지) - 오디오 콘텐츠에 오디오 신호 이외의 오디오 또는 비표준 오디오가 녹음된 경우와 같이 오디오 녹음 상태에 따라 오디오가 출력되지 않을 수 있습니다. (3페이지)
오디오의 좌우 채널이 바뀌거나 사운드가 한 쪽에서만 출력된다.	<ul style="list-style-type: none"> - 오디오 연결을 확인하십시오. (10페이지)
오디오가 출력되지 않거나 화상이 올바르게 재생되지 않는다.	<ul style="list-style-type: none"> - 저작권 보호 콘텐츠가 녹화된 일부 디스크의 경우 오디오가 출력되지 않거나 화상이 올바르게 재생되지 않을 수 있습니다.
원하는 오디오 유형/채널 번호를 들을 수 없다.	<ul style="list-style-type: none"> - Audio Output 설정 및 "오디오 출력 형식에 대하여"를 참조하십시오. (34, 35페이지)
PIP 사운드(보조 오디오)가 들리지 않는다.	<ul style="list-style-type: none"> - Coaxial/Optical 또는 HDMI를 PCM/Reencode로 설정하십시오. (34페이지) - 보조 오디오를 들으려면 2ND AUDIO를 누르십시오. (6페이지) - 디스크에 따라 디스크의 맨 처음 메뉴에서 보조 오디오를 On으로 설정해야 하는 경우도 있습니다. (7페이지)

■ 네트워크

문제	원인 및 해결 방법
인터넷에 연결할 수 없다.	<ul style="list-style-type: none"> - 네트워크 케이블을 올바르게 연결하십시오. - 광대역 라우터 또는 모뎀 등 연결된 기기의 전원을 켜십시오. - 광대역 라우터 및/또는 모뎀을 올바르게 연결하십시오. - 네트워크 설정에서 올바른 값을 설정하십시오. "Network"를 확인하십시오. (32페이지)
BD-Live 콘텐츠를 다운로드할 수 없다.	<ul style="list-style-type: none"> - 네트워크 케이블을 올바르게 연결하십시오. (16페이지) - USB 메모리 장치를 올바르게 연결하십시오. USB 메모리 장치가 본 플레이어의 USB 포트에 연결되어 있는지 확인하십시오. (16페이지) - BD 디스크가 BD-Live를 지원하는지 확인하십시오. - "Internet Connection"의 설정을 확인하십시오. (32페이지) - FAT16 또는 FAT32로 포맷된 USB 메모리 장치를 연결하십시오. - 여유 공간이 2 GB 이상인 USB 메모리 장치를 연결하는 것이 좋습니다. 여유 공간이 충분하지 않을 경우 USB 메모리 장치를 포맷하십시오. (30페이지) - 디스크와 함께 제공된 사용 설명서를 참조하거나 디스크 제조업체에 문의하십시오.
DLNA 서버가 감지되지 않는다.	<ul style="list-style-type: none"> - 네트워크 케이블을 올바르게 연결하십시오. - 광대역 라우터 또는 서버 등 연결된 기기의 전원을 켜십시오. - 플레이어 및 서버가 동일한 액세스 포인트에 연결되어 있는지 확인하십시오. - 네트워크 설정에서 올바른 값을 설정하십시오. "Network"를 확인하십시오. (32페이지) - DLNA 서버에 따라, 서버로부터 플레이어를 허가 받아야 할 수도 있습니다.
홈 네트워크 서버에서 파일을 재생할 수 없다.	<ul style="list-style-type: none"> - 재생 가능한 파일인지 확인하십시오. (3페이지) - DLNA 서버의 설정을 확인하십시오. - 홈 네트워크 조건에 따라 재생 및 작동 상태가 영향을 받을 수 있습니다.

■ 화면의 메시지

- 재생하려는 디스크가 적합하지 않거나 조각이 잘못된 경우 TV 화면에 다음과 같은 메시지가 나타납니다.

오류 메시지	원인 및 해결 방법
Not Support This File!	- 파일이 본 플레이어에서 지원되지 않습니다. "본 플레이어에서 사용할 수 있는 디스크/파일 유형" (3페이지)을 참조하십시오.
Wrong region code!	- 디스크의 지역 코드가 호환되지 않습니다. "지역 관리 정보"(3페이지)를 참조하십시오.
Network has FAILED.	- 본 플레이어를 네트워크에 연결할 수 없습니다. 연결(16페이지) 및 Network 설정(32페이지)을 확인하십시오.
Network is OK, proxy has FAILED.	- 본 플레이어를 프록시 서버에 연결할 수 없습니다. "Proxy Setting"(32페이지)을 참조하십시오.
The Setting is prohibited, please setup again.	- BD-Live 연결이 금지되어 있습니다. "BD-Live Connection"(32페이지)을 참조하십시오.
No valid upgrade file is found!	- 업그레이드 파일이 적절한 폴더에 있는지 확인하십시오.
Upgrade has failed for some reason!	- 업그레이드가 실패했습니다. 업그레이드 파일이 손상되었는지 또는 읽을 수 없는 파일인지 확인하십시오.

AVCHD

AVCHD는 고해상도 HD 화상을 녹화 및 재생할 수 있는 고선명 비디오 카메라의 새로운 형식(표준)입니다.

BD-Live™

BD-Live는 네트워크 연결을 사용할 수 있는 BD 표준으로, 본 플레이어에서 온라인에 연결하여 판촉용 영상이나 기타 데이터를 다운로드할 수 있습니다.

BDMV

BDMV(Blu-ray Disc Movie, BD-MV)는 Blu-ray Disc 규격의 하나인 BD-ROM에서 사용되는 응용 프로그램 형식 중 하나입니다. BDMV는 DVD 규격의 DVD-Video와 동일한 녹화 형식입니다.

Blu-ray 3D™

Blu-ray 3D는 풀 HD 3D 영상을 제공합니다.

BONUSVIEW

BONUSVIEW 호환 디스크를 사용하면 두 개의 화면용 비디오 하위 채널, 오디오 하위 채널 및 하위 타이틀을 동시에 즐길 수 있습니다. 재생 도중 기본 화면 안에 작은 화면이 나타납니다(Picture in Picture).

자막 방송

자막 방송은 자막의 일종이지만, 자막은 일반 사람들을 위한 것이고 자막 방송은 청각 장애인용이라는 점이 서로 다릅니다. 자막에는 모든 오디오가 거의 표시되지 않습니다. 예를 들어, 자막에서는 사운드 효과(예: "전화벨 소리" 및 "발자국 소리")가 나타나지만, 자막 방송에서는 그렇지 않습니다. 이 설정을 선택하기 전에 디스크에 자막 방송 정보가 포함되어 있는지 확인하십시오.

Color Space

Color Space는 표현할 수 있는 색상 범위입니다. RGB는 RGB 색상 모델(적색, 녹색 및 청색)을 기준으로 하는 색상 공간이며 일반적으로 PC 모니터에 사용됩니다. YCbCr는 휘도 신호(Y) 및 색차 신호(Cb 및 Cr)를 기준으로 하는 색상 공간입니다.

Deep Color

Deep Color는 디스플레이에서 다양한 색심도를 사용하는 것으로, 이전 버전의 HDMI 규격에서는 최대 24비트 깊이까지 사용합니다. 이렇게 비트 심도가 높아지면 HDTV 및 다른 디스플레이에서 수백만 색상에서 수십억 색상까지 표시할 수 있으며, 화면의 컬러 밴딩을 제거하여 색조 전환 및 색상 간 그래데이션이 매끄러워집니다. 음영비가 증가되면 검은색과 흰색 사이에 몇 배나 더 많은 회색 음영을 표현할 수 있습니다. 또한 Deep Color는 RGB 또는 YCbCr 색상 공간에서 정의한 범위 내에서 사용할 수 있는 색상 수가 늘어납니다.

DivX

DivX®는 DivX, Inc.에서 개발하여 널리 사용되는 미디어 기술입니다. DivX® 파일에는 고화질이지만 상대적으로 파일 크기가 작고 고도로 압축된 비디오가 포함되어 있습니다. 또한 DivX® 파일에는 메뉴, 자막 및 대체 오디오 트랙 같은 고급 미디어 기능이 포함되어 있습니다. 많은 DivX® 미디어 파일을 온라인에서 다운로드할 수 있으며, DivX.com에서 개인 콘텐츠와 간단한 툴을 사용하여 직접 만들 수 있습니다.

Dolby Digital

Dolby Laboratories Inc.에서 개발한 사운드 시스템으로, 제품을 Dolby Digital 프로세서 또는 애플에 연결하면 영화관과 같은 오디오 출력이 제공됩니다.

Dolby Digital Plus

Dolby Digital의 확장으로서 개발된 사운드 시스템입니다. 이 오디오 코딩 기술은 7.1 멀티 채널 서라운드 사운드를 지원합니다.

Dolby TrueHD

Dolby TrueHD는 차세대 광 디스크용 최대 8개의 멀티 채널 서라운드 사운드를 지원하는 무손실 코딩 기술입니다. 재생된 사운드는 비트마다 원음에 충실합니다.

DRC(Dynamic Range Control)

DRC를 사용하여 평균 음량으로 재생 시 최강음과 최약음 사이의 범위(동적 범위)를 조정할 수 있습니다. 대화가 잘 들리지 않거나 이웃에 피해를 줄 수 있는 시간에 재생하는 경우 사용하십시오.

DSD(Direct Stream Digital)

DSD 기술은 Super Audio CD 같은 디지털 저장 매체에 오디오 신호를 저장합니다. DSD를 사용하면, 신호가 2.8224 MHz의 고주파수 샘플링 속도의 단일 비트값으로 저장되고, 노이즈 셰이핑 및 오버 샘플링을 사용하여 오디오 신호의 양자화에서 일반적으로 발생하는 왜곡을 줄입니다. 샘플링 속도가 높기 때문에 일반 오디오 CD에 사용되는 PCM에서 제공하는 것보다 훨씬 좋은 음질을 얻을 수 있습니다.

DTS

이것은 영화에서 사용하기 위해 DTS, Inc.에서 개발한 디지털 사운드 시스템입니다.

DTS-HD High Resolution Audio

DTS-HD High Resolution Audio는 차세대 고선명 광 디스크 형식을 위해 개발된 신기술입니다.

DTS-HD Master Audio

DTS-HD Master Audio는 차세대 고선명 광 디스크 형식을 위해 개발된 무손실 오디오 압축 기술입니다.

DTS-HD Master Audio | Essential

DTS-HD Master Audio | Essential은 차세대 고선명 광 디스크 형식을 위해 개발된 무손실 오디오 압축 기술입니다.

HDMI

HDMI(High-Definition Multimedia Interface)는 하나의 디지털 연결로 비디오와 오디오를 모두 지원하는 인터페이스입니다. HDMI 연결은 고선명 비디오 신호 및 멀티 채널 오디오 신호를 품질 저하 없이 디지털 형태로 HDMI가 장착된 TV 같은 AV 컴포넌트로 전달합니다.

Letterbox(LB 4:3)

화상의 위아래에 검은색 막대가 나타나는 화면 크기로, 연결된 4:3 TV에서 와이드 스크린(16:9) 영상을 볼 수 있습니다.

Linear PCM 사운드

Linear PCM는 오디오 CD 및 일부 DVD 및 Blu-ray 디스크에서 사용되는 신호 기록 형식입니다. 오디오 CD의 사운드는 16비트 44.1 kHz로 기록됩니다. (DVD 디스크에서 사운드는 16비트 48 kHz 및 24비트 96 kHz 사이에 기록되고, BD 디스크에서는 16비트 48 kHz 및 24비트 192 kHz 사이에 기록됩니다.)

Lip Sync

Lip Sync는 lip synchronization(립싱크)의 약자로, 제작 후 및 전송 과정에서 오디오 신호와 비디오 신호가 동기화되도록 유지하는 문제 및 성능과 관련된 기술 용어입니다. 오디오 및 비디오 지연의 경우 사용자가 복잡한 조정을 해야 하는 반면, HDMI 버전 1.3에서는 자동 오디오 및 비디오 싱크 기능을 통합하여 사용자의 개입 없이 장치에서 동기화를 자동으로 정확하게 수행할 수 있습니다.

Mac 주소

Mac 주소는 식별을 위해 네트워크 장치에 할당된 고유한 값입니다.

Pan Scan(PS 4:3)

화상의 양쪽을 잘라낸 화면 크기를 사용하여 연결된 4:3 TV에서 와이드 스크린(16:9) 영상을 볼 수 있습니다.

자막

자막은 화면 아래쪽에 표시되어 대화를 번역 또는 기술하는 텍스트 줄입니다. 자막은 주로 DVD 및 BD 디스크에 기록되어 있습니다.

맨 처음 메뉴

BD-Video/DVD-Video의 경우, 재생할 챕터 및 자막 언어 등을 선택하는 메뉴입니다. 일부 DVD-Video에서 맨 처음 메뉴를 "타이틀 메뉴"라고도 합니다.

x.v.Color

x.v.Color는 전보다 넓은 범위의 색상을 재현할 수 있어서 인간의 눈으로 감지할 수 있는 거의 모든 색상을 표시할 수 있습니다.

제품 사양

■ 일반 사양

전원

[미국 및 캐나다 모델].....	AC 110-240 V, 60 Hz
[중남미 모델]	AC 110-240 V, 50/60 Hz
[유럽 및 러시아 모델].....	AC 230 V, 50 Hz
[호주 모델].....	AC 110-240 V, 50 Hz
[아시아 모델]	AC 220-240 V, 50/60 Hz
[대만 모델].....	AC 110-120 V, 50/60 Hz
[한국 모델].....	AC 220 V, 60 Hz
소비 전력(일반).....	25 W
소비 전력(대기).....	0.5 W 이하
크기(W×H×D).....	435×96×316 mm
무게.....	4.05 kg

■ 오디오 성능

오디오 출력 레벨(1 kHz, 0 dB, BD/DVD/CD-DA).....	2 ± 0.3 V
신호 대 잡음비(BD/DVD/CD-DA)	115 dB 이상
동적 범위	
BD/DVD	105 dB 이상
CD-DA	100 dB 이상
고조파 왜곡(1 kHz)	
BD/DVD	0.0028 % 이하
CD-DA	0.003 % 이하
주파수 응답	
BD/DVD	2 Hz에서 22 kHz(48 kHz 샘플링)
	2 Hz에서 44 kHz(96 kHz 샘플링)
CD-DA.....	2 Hz에서 20 kHz

■ 입력/출력

HDMI 출력	타입 A 커넥터 × 1
	480i/576i/480p/576p/720p/1080i/1080p/1080p@24Hz,
	Deep Color, x.v. 색상 지원
컴포넌트 비디오 출력.....	Y: 1 Vp-p(75 ohms)
	Pb, Pr: 0.7 Vp-p(75 ohms)
비디오 출력	1 Vp-p(75 ohms)
디지털 출력	광 × 1, 동축 × 1
아날로그 오디오 출력.....	7.1 ch × 1,
	Mixed 2 ch × 1
USB.....	타입 A 커넥터 × 2
기타 장비	Remote IN/OUT × 1,
	RS-232C × 1(커스텀 인스톨러용),
	이더넷 × 1

제품 사양은 사전 예고 없이 변경될 수 있습니다.

■ 저작권

- 오디오 비디오 영상에는 저작권자의 권한이 없으면 녹화할 수 없는 저작권 보호 작품이 포함되어 있을 수 있습니다. 국내 관련 법규를 참조하십시오.
- 이 항목은 미국 특허 및 Rovi Corporation의 다른 지적 재산권의 보호를 받는 저작권 보호 기술을 통합합니다. 리버스 엔지니어링 및 분해는 금지됩니다.
- Dolby Laboratories의 사용허락 아래 제작되었습니다. Dolby 및 이중 D 기호는 Dolby Laboratories의 상표입니다.
- 미국 특허 번호 5,451,942; 5,956,674; 5,974,380; 5,978,762; 6,226,616; 6,487,535; 7,212,872; 7,333,929; 7,392,195; 7,272,567 및 미국과 전세계에서 출원 필했거나 출원 중인 기타 특허로 제조되었습니다. DTS 및 그 기호는 등록 상표이며 DTS-HD, DTS-HD Master Audio 및 DTS 로고는 DTS, Inc.의 상표입니다. 제품에는 소프트웨어가 포함됩니다. © DTS, Inc. 모든 권리 보유.
- "Blu-ray Disc™", "Blu-ray™", "Blu-ray 3D™", "BD-Live™", "BONUSVIEW™" 및 로고들은 Blu-ray Disc Association의 상표입니다.
- **DVD**는 DVD Format/Logo Licensing Corporation의 상표입니다.
- HDMI, HDMI 로고 및 High-Definition Multimedia Interface는 HDMI Licensing LLC의 상표 또는 등록 상표입니다.
- "x.v.Color" 및 "x.v.Color" 로고는 상표입니다.
- "AVCHD" 및 "AVCHD" 로고는 Panasonic Corporation 및 Sony Corporation의 상표입니다.
- Java 및 모든 Java 기반 상표와 로고는 미국 및/또는 기타 국가에서 Sun Microsystems, Inc.의 상표 또는 등록 상표입니다.
- 이 제품은 AVC 특허 포트폴리오 및 VC-1 특허 포트폴리오 라이선스 하에서 다음과 같은 개인적이고 비상업적인 용도로 사용하는 경우에 한하여 허가를 받았습니다. (i) AVC 표준 및 VC-1 표준 ("AVC/VC-1 비디오")에 호환되는 비디오 인코딩 및/또는 (ii) 개인적이고 비상업적인 업무에 종사하는 사용자가 인코딩한 AVC/VC-1 비디오의 디코딩 및/또는 AVC/VC-1 비디오 배급 허가가 있는 비디오 공급자가 제공한 AVC/VC-1 비디오의 디코딩. 그 외 용도로는 라이선스가 허가되거나 묵시적으로도 인정되지 않습니다. 자세한 내용은 MPEG LA, LLC에서 얻을 수 있습니다. <http://www.mpegla.com>을 참조하십시오.
- Windows Media Player는 미국 및/또는 기타 국가에서 Microsoft corporation의 등록 상표 또는 상표입니다.
- DLNA 및 DLNA CERTIFIED는 Digital Living Network Alliance의 상표 및/또는 서비스 마크입니다.
- YouTube 및 YouTube 로고는 Google, Inc의 상표입니다.
- "DivX®, DivX Certified®, DivX Plus™ HD 및 관련 로고는 DivX, Inc.의 등록 상표이고 라이선스 하에 사용되었습니다."
- "DivX Certified®는 최대 1080p HD 및 프리미엄 콘텐츠 DivX® 및 DivX Plus™ HD(H.264/.MKV) 비디오 재생용입니다."

ABOUT DIVX VIDEO: DivX®는 DivX, Inc.에서 만든 디지털 비디오 형식입니다. 이 형식은 DivX 비디오를 재생하는 공식 DivX Certified® 장치입니다. 자세한 정보 및 파일을 DivX 비디오로 변환하는 소프트웨어 툴에 대해 알아보려면 divx.com을 방문하십시오.

ABOUT DIVX VIDEO-ON-DEMAND: 구입한 DivX Video-on-Demand (VOD) 동영상을 재생하려면 이 DivX Certified® 장치를 등록해야 합니다. 등록 코드를 얻으려면, 장치 설정 메뉴에서 DivX VOD 섹션으로 이동하십시오. vod.divx.com을 방문하여 등록을 완료하는 방법에 대해 자세히 알아보십시오.

Information about software

This product uses the following software.

For information (copyright, etc) about each software, read the original sentences stated below.

■ About Linux, Busybox, SquashFS, LIRC, U-boot

GNU GENERAL PUBLIC LICENSE
Version 2, June 1991

Copyright (C) 1989, 1991 Free Software Foundation, Inc.
51 Franklin St, Fifth Floor, Boston, MA 02110-1301 USA

Everyone is permitted to copy and distribute verbatim copies of this license document, but changing it is not allowed.

Preamble

The licenses for most software are designed to take away your freedom to share and change it. By contrast, the GNU General Public License is intended to guarantee your freedom to share and change free software—to make sure the software is free for all its users. This General Public License applies to most of the Free Software Foundation's software and to any other program whose authors commit to using it. (Some other Free Software Foundation software is covered by the GNU Library General Public License instead.) You can apply it to your programs, too.

When we speak of free software, we are referring to freedom, not price. Our General Public Licenses are designed to make sure that you have the freedom to distribute copies of free software (and charge for this service if you wish), that you receive source code or can get it if you want it, that you can change the software or use pieces of it in new free programs; and that you know you can do these things.

To protect your rights, we need to make restrictions that forbid anyone to deny you these rights or to ask you to surrender the rights. These restrictions translate to certain responsibilities for you if you distribute copies of the software, or if you modify it. For example, if you distribute copies of such a program, whether gratis or for a fee, you must give the recipients all the rights that you have. You must make sure that they, too, receive or can get the source code. And you must show them these terms so they know their rights.

We protect your rights with two steps: (1) copyright the software, and (2) offer you this license which gives you legal permission to copy, distribute and/or modify the software. Also, for each author's protection and ours, we want to make certain that everyone understands that there is no warranty for this free software. If the software is modified by someone else and passed on, we want its recipients to know that what they have is not the original, so that any problems introduced by others will not reflect on the original authors' reputations.

Finally, any free program is threatened constantly by software patents. We wish to avoid the danger that redistributors of a free program will individually obtain patent licenses, in effect making the program proprietary. To prevent this, we have made it clear that any patent must be licensed for everyone's free use or not licensed at all. The precise terms and conditions for copying, distribution and modification follow.

GNU GENERAL PUBLIC LICENSE TERMS AND CONDITIONS FOR COPYING, DISTRIBUTION AND MODIFICATION

- This License applies to any program or other work which contains a notice placed by the copyright holder saying it may be distributed under the terms of this General Public License. The "Program", below, refers to any such program or work, and a "work based on the Program" means either the Program or any derivative work under copyright law: that is to say, a work containing the Program or a portion of it, either verbatim or with modifications and/or translated into another language. (Hereinafter, translation is included without limitation in the term "modification".) Each licensee is addressed as "you".
Activities other than copying, distribution and modification are not covered by this License; they are outside its scope. The act of running the Program is not restricted, and the output from the Program is covered only if its contents constitute a work based on the Program (independent of having been made by running the Program). Whether that is true depends on what the Program does.
- You may copy and distribute verbatim copies of the Program's source code as you receive it, in any medium, provided that you conspicuously and appropriately publish on each copy an appropriate copyright notice and disclaimer of warranty; keep intact all the notices that refer to this License and to the absence of any warranty; and give any other recipients of the Program a copy of this License along with the Program.
You may charge a fee for the physical act of transferring a copy, and you may at your option offer warranty protection in exchange for a fee.
- You may modify your copy or copies of the Program or any portion of it, thus forming a work based on the Program, and copy and distribute such modifications or work under the terms of Section 1 above, provided that you also meet all of these conditions:
 - You must cause the modified files to carry prominent notices stating that you changed the files and the date of any change.
 - You must cause any work that you distribute or publish, that in whole or in part contains or is derived from the Program or any part thereof, to be licensed as a whole at no charge to all third parties under the terms of this License.
 - If the modified program normally reads commands interactively when run, you must cause it, when started running for such interactive use in the most ordinary way, to print or display an announcement including an appropriate copyright notice and a notice that there is no warranty (or else, saying that you provide a warranty) and that users may redistribute the program under these conditions, and telling the user how to view a copy of this License. (Exception: if the Program itself is interactive but does not normally print such an announcement, your work based on the Program is not required to print an announcement.)

These requirements apply to the modified work as a whole. If identifiable sections of that work are not derived from the Program, and can be reasonably considered independent and separate works in themselves, then this License, and its terms, do not apply to those sections when you distribute them as separate works. But when you distribute the same sections as part of a whole which is a work based on the Program, the distribution of the whole must be on the terms of this License, whose permissions for other licensees extend to the entire whole, and thus to each and every part regardless of who wrote it.

Thus, it is not the intent of this section to claim rights or contest your rights to work written entirely by you; rather, the intent is to exercise the right to control the distribution of derivative or collective works based on the Program.

In addition, mere aggregation of another work not based on the Program with the Program (or with a work based on the Program) on a volume of a storage or distribution medium does not bring the other work under the scope of this License.

- You may copy and distribute the Program (or a work based on it, under Section 2) in object code or executable form under the terms of Sections 1 and 2 above provided that you also do one of the following:
 - Accompany it with the complete corresponding machine-readable source code, which must be distributed under the terms of Sections 1 and 2 above on a medium customarily used for software interchange; or,
 - Accompany it with a written offer, valid for at least three years, to give any third party, for a charge no more than your cost of physically performing source distribution, a complete machine-readable copy of the corresponding source code, to be distributed under the terms of Sections 1 and 2 above on a medium customarily used for software interchange; or,
 - Accompany it with the information you received as to the offer to distribute corresponding source code. (This alternative is allowed only for noncommercial distribution and only if you received the program in object code or executable form with such an offer, in accord with Subsection b above.)

The source code for a work means the preferred form of the work for making modifications to it. For an executable work, complete source code means all the source code for all modules it contains, plus any associated interface definition files, plus the scripts used to control compilation and installation of the executable. However, as a special exception, the source code distributed need not include anything that is normally distributed (in either source or binary form) with the major components (compiler, kernel, and so on) of the operating system on which the executable runs, unless that component itself accompanies the executable.

If distribution of executable or object code is made by offering access to copy from a designated place, then offering equivalent access to copy the source code from the same place counts as distribution of the source code, even though third parties are not compelled to copy the source along with the object code.

- You may not copy, modify, sublicense, or distribute the Program except as expressly provided under this License. Any attempt otherwise to copy, modify, sublicense or distribute the Program is void, and will automatically terminate your rights under this License. However, parties who have received copies, or rights, from you under this License will not have their licenses terminated so long as such parties remain in full compliance.
- You are not required to accept this License, since you have not signed it. However, nothing else grants you permission to modify or distribute the Program or its derivative works. These actions are prohibited by law if you do not accept this License. Therefore, by modifying or distributing the Program (or any work based on the Program), you indicate your acceptance of this License to do so, and all its terms and conditions for copying, distributing or modifying the Program or works based on it.
- Each time you redistribute the Program (or any work based on the Program), the recipient automatically receives a license from the original licensor to copy, distribute or modify the Program subject to these terms and conditions. You may not impose any further restrictions on the recipients' exercise of the rights granted herein. You are not responsible for enforcing compliance by third parties to this License.
- If, as a consequence of a court judgment or allegation of patent infringement or for any other reason (not limited to patent issues), conditions are imposed on you (whether by court order, agreement or otherwise) that contradict the conditions of this License, they do not excuse you from the conditions of this License. If you cannot distribute so as to satisfy simultaneously your obligations under this License and any other pertinent obligations, then as a consequence you may not distribute the Program at all. For example, if a patent license would not permit royalty-free redistribution of the Program by all those who receive copies directly or indirectly through you, then the only way you could satisfy both it and this License would be to refrain entirely from distribution of the Program.

If any portion of this section is held invalid or unenforceable under any particular circumstance, the balance of the section is intended to apply and the section as a whole is intended to apply in other circumstances.

It is not the purpose of this section to induce you to infringe any patents or other property right claims or to contest validity of any such claims; this section has the sole purpose of protecting the integrity of the free software distribution system, which is implemented by public license practices. Many people have made generous contributions to the wide range of software distributed through that system in reliance on consistent application of that system; it is up to the author/donor to decide if he or she is willing to distribute software through any other system and a licensee cannot impose that choice.

This section is intended to make thoroughly clear what is believed to be a consequence of the rest of this License.

8. If the distribution and/or use of the Program is restricted in certain countries either by patents or by copyrighted interfaces, the original copyright holder who places the Program under this License may add an explicit geographical distribution limitation excluding those countries, so that distribution is permitted only in or among countries not thus excluded. In such case, this License incorporates the limitation as if written in the body of this License.

9. The Free Software Foundation may publish revised and/or new versions of the General Public License from time to time. Such new versions will be similar in spirit to the present version, but may differ in detail to address new problems or concerns.

Each version is given a distinguishing version number. If the Program specifies a version number of this License which applies to it and "any later version", you have the option of following the terms and conditions either of that version or of any later version published by the Free Software Foundation. If the Program does not specify a version number of this License, you may choose any version ever published by the Free Software Foundation.

10. If you wish to incorporate parts of the Program into other free programs whose distribution conditions are different, write to the author to ask for permission. For software which is copyrighted by the Free Software Foundation, write to the Free Software Foundation; we sometimes make exceptions for this. Our decision will be guided by the two goals of preserving the free status of all derivatives of our free software and of promoting the sharing and reuse of software generally.

NO WARRANTY

11. BECAUSE THE PROGRAM IS LICENSED FREE OF CHARGE, THERE IS NO WARRANTY FOR THE PROGRAM, TO THE EXTENT PERMITTED BY APPLICABLE LAW. EXCEPT WHEN OTHERWISE STATED IN WRITING THE COPYRIGHT HOLDERS AND/OR OTHER PARTIES PROVIDE THE PROGRAM "AS IS" WITHOUT WARRANTY OF ANY KIND, EITHER EXPRESSED OR IMPLIED, INCLUDING, BUT NOT LIMITED TO, THE IMPLIED WARRANTIES OF MERCHANTABILITY AND FITNESS FOR A PARTICULAR PURPOSE. THE ENTIRE RISK AS TO THE QUALITY AND PERFORMANCE OF THE PROGRAM IS WITH YOU. SHOULD THE PROGRAM PROVE DEFECTIVE, YOU ASSUME THE COST OF ALL NECESSARY SERVICING, REPAIR OR CORRECTION.

12. IN NO EVENT UNLESS REQUIRED BY APPLICABLE LAW OR AGREED TO IN WRITING WILL ANY COPYRIGHT HOLDER, OR ANY OTHER PARTY WHO MAY MODIFY AND/OR REDISTRIBUTE THE PROGRAM AS PERMITTED ABOVE, BE LIABLE TO YOU FOR DAMAGES, INCLUDING ANY GENERAL, SPECIAL, INCIDENTAL OR CONSEQUENTIAL DAMAGES ARISING OUT OF THE USE OR INABILITY TO USE THE PROGRAM (INCLUDING BUT NOT LIMITED TO LOSS OF DATA OR DATA BEING RENDERED INACCURATE OR LOSSES SUSTAINED BY YOU OR THIRD PARTIES OR A FAILURE OF THE PROGRAM TO OPERATE WITH ANY OTHER PROGRAMS), EVEN IF SUCH HOLDER OR OTHER PARTY HAS BEEN ADVISED OF THE POSSIBILITY OF SUCH DAMAGES.

END OF TERMS AND CONDITIONS

How to Apply These Terms to Your New Programs

If you develop a new program, and you want it to be of the greatest possible use to the public, the best way to achieve this is to make it free software which everyone can redistribute and change under these terms.

To do so, attach the following notices to the program. It is safest to attach them to the start of each source file to most effectively convey the exclusion of warranty; and each file should have at least the "copyright" line and a pointer to where the full notice is found.

<one line to give the program's name and a brief idea of what it does.>

Copyright (C) <year> <name of author>

This program is free software; you can redistribute it and/or modify it under the terms of the GNU General Public License as published by the Free Software Foundation; either version 2 of the License, or (at your option) any later version.

This program is distributed in the hope that it will be useful, but WITHOUT ANY WARRANTY; without even the implied warranty of MERCHANTABILITY or FITNESS FOR A PARTICULAR PURPOSE. See the GNU General Public License for more details.

You should have received a copy of the GNU General Public License along with this program; if not, write to the Free Software Foundation, Inc., 51 Franklin St, Fifth Floor, Boston, MA 02110-1301 USA

Also add information on how to contact you by electronic and paper mail.

If the program is interactive, make it output a short notice like this when it starts in an interactive mode:

Gnomovision version 69, Copyright (C) year name of author Gnomovision comes with ABSOLUTELY NO WARRANTY; for details type 'show w'. This is free software, and you are welcome to redistribute it under certain conditions; type 'show c' for details.

The hypothetical commands 'show w' and 'show c' should show the appropriate parts of the General Public License. Of course, the commands you use may be called something other than 'show w' and 'show c'; they could even be mouse-clicks or menu items--whatever suits your program.

You should also get your employer (if you work as a programmer) or your school, if any, to sign a "copyright disclaimer" for the program, if necessary. Here is a sample; alter the names:

Yooyodyne, Inc., hereby disclaims all copyright interest in the program 'Gnomovision' (which makes passes at compilers) written by James Hacker.

<signature of Ty Coon>, 1 April 1989

Ty Coon, President of Vice

This General Public License does not permit incorporating your program into proprietary programs. If your program is a subroutine library, you may consider it more useful to permit linking proprietary applications with the library. If this is what you want to do, use the GNU Library General Public License instead of this License..

■ About glibc, libmtp, libusb, libusb-compat, DirectFB

GNU LESSER GENERAL PUBLIC LICENSE

Version 2.1, February 1999

Copyright (C) 1991, 1999 Free Software Foundation, Inc.
59 Temple Place, Suite 330, Boston, MA 02111-1307 USA

Everyone is permitted to copy and distribute verbatim copies of this license document, but changing it is not allowed.

[This is the first released version of the Lesser GPL. It also counts as the successor of the GNU Library Public License, version 2, hence the version number 2.1.]

Preamble

The licenses for most software are designed to take away your freedom to share and change it. By contrast, the GNU General Public Licenses are intended to guarantee your freedom to share and change free software--to make sure the software is free for all its users.

This license, the Lesser General Public License, applies to some specially designated software packages--typically libraries--of the Free Software Foundation and other authors who decide to use it. You can use it too, but we suggest you first think carefully about whether this license or the ordinary General Public License is the better strategy to use in any particular case, based on the explanations below.

When we speak of free software, we are referring to freedom of use, not price. Our General Public Licenses are designed to make sure that you have the freedom to distribute copies of free software (and charge for this service if you wish); that you receive source code or can get it if you want it; that you can change the software and use pieces of it in new free programs; and that you are informed that you can do these things.

To protect your rights, we need to make restrictions that forbid distributors to deny you these rights or to ask you to surrender these rights. These restrictions translate to certain responsibilities for you if you distribute copies of the library or if you modify it. For example, if you distribute copies of the library, whether gratis or for a fee, you must give the recipients all the rights that we gave you. You must make sure that they, too, receive or can get the source code. If you link other code with the library, you must provide complete object files to the recipients, so that they can relink them with the library after making changes to the library and recompiling it. And you must show them these terms so they know their rights.

We protect your rights with a two-step method: (1) we copyright the library, and (2) we offer you this license, which gives you legal permission to copy, distribute and/or modify the library.

To protect each distributor, we want to make it very clear that there is no warranty for the free library. Also, if the library is modified by someone else and passed on, the recipients should know that what they have is not the original version, so that the original author's reputation will not be affected by problems that might be introduced by others.

Finally, software patents pose a constant threat to the existence of any free program.

We wish to make sure that a company cannot effectively restrict the users of a free program by obtaining a restrictive license from a patent holder. Therefore, we insist that any patent license obtained for a version of the library must be consistent with the full freedom of use specified in this license.

Most GNU software, including some libraries, is covered by the ordinary GNU General Public License. This license, the GNU Lesser General Public License, applies to certain designated libraries, and is quite different from the ordinary General Public License. We use this license for certain libraries in order to permit linking those libraries into non-free programs.

When a program is linked with a library, whether statically or using a shared library, the combination of the two is legally speaking a combined work, a derivative of the original library. The ordinary General Public License therefore permits such linking only if the entire combination fits its criteria of freedom. The Lesser General Public License permits more lax criteria for linking other code with the library.

We call this license the "Lesser" General Public License because it does Less to protect the user's freedom than the ordinary General Public License. It also provides other free software developers Less of an advantage over competing non-free programs. These disadvantages are the reason we use the ordinary General Public License for many libraries. However, the Lesser license provides advantages in certain special circumstances.

For example, on rare occasions, there may be a special need to encourage the widest possible use of a certain library, so that it becomes a de-facto standard. To achieve this, non-free programs must be allowed to use the library. A more frequent case is that a free library does the same job as widely used non-free libraries. In this case, there is little to gain by limiting the free library to free software only, so we use the Lesser General Public License.

In other cases, permission to use a particular library in non-free programs enables a greater number of people to use a large body of free software. For example, permission to use the GNU C Library in non-free programs enables many more people to use the whole GNU operating system, as well as its variant, the GNU/Linux operating system. Although the Lesser General Public License is Less protective of the users' freedom, it does ensure that the user of a program that is linked with the Library has the freedom and the wherewithal to run that program using a modified version of the Library.

The precise terms and conditions for copying, distribution and modification follow. Pay close attention to the difference between a "work based on the library" and a "work that uses the library". The former contains code derived from the library, whereas the latter must be combined with the library in order to run.

GNU LESSER GENERAL PUBLIC LICENSE
TERMS AND CONDITIONS FOR COPYING, DISTRIBUTION AND
MODIFICATION

0. This License Agreement applies to any software library or other program which contains a notice placed by the copyright holder or other authorized party saying it may be distributed under the terms of this Lesser General Public License (also called "this License"). Each licensee is addressed as "you".

A "library" means a collection of software functions and/or data prepared so as to be conveniently linked with application programs (which use some of those functions and data) to form executables.

The "Library", below, refers to any such software library or work which has been distributed under these terms. A "work based on the Library" means either the Library or any derivative work under copyright law: that is to say, a work containing the Library or a portion of it, either verbatim or with modifications and/or translated straightforwardly into another language. (Hereinafter, translation is included without limitation in the term "modification".)

"Source code" for a work means the preferred form of the work for making modifications to it. For a library, complete source code means all the source code for all modules it contains, plus any associated interface definition files, plus the scripts used to control compilation and installation of the library.

Activities other than copying, distribution and modification are not covered by this License; they are outside its scope. The act of running a program using the Library is not restricted, and output from such a program is covered only if its contents constitute a work based on the Library (independent of the use of the Library in a tool for writing it). Whether that is true depends on what the Library does and what the program that uses the Library does.

1. You may copy and distribute verbatim copies of the Library's complete source code as you receive it, in any medium, provided that you conspicuously and appropriately publish on each copy an appropriate copyright notice and disclaimer of warranty; keep intact all the notices that refer to this License and to the absence of any warranty; and distribute a copy of this License along with the Library.

You may charge a fee for the physical act of transferring a copy, and you may at your option offer warranty protection in exchange for a fee.

2. You may modify your copy or copies of the Library or any portion of it, thus forming a work based on the Library, and copy and distribute such modifications or work under the terms of Section 1 above, provided that you also meet all of these conditions:

- a) The modified work must itself be a software library.
- b) You must cause the files modified to carry prominent notices stating that you changed the files and the date of any change.
- c) You must cause the whole of the work to be licensed at no charge to all third parties under the terms of this License.
- d) If a facility in the modified Library refers to a function or a table of data to be supplied by an application program that uses the facility, other than as an argument passed when the facility is invoked, then you must make a good faith effort to ensure that, in the event an application does not supply such function or table, the facility still operates, and performs whatever part of its purpose remains meaningful.

(For example, a function in a library to compute square roots has a purpose that is entirely well-defined independent of the application. Therefore, Subsection 2d requires that any application-supplied function or table used by this function must be optional: if the application does not supply it, the square root function must still compute square roots.)

These requirements apply to the modified work as a whole. If identifiable sections of that work are not derived from the Library, and can be reasonably considered independent and separate works in themselves, then this License, and its terms, do not apply to those sections when you distribute them as separate works. But when you distribute the same sections as part of a whole which is a work based on the Library, the distribution of the whole must be on the terms of this License, whose permissions for other licensees extend to the entire whole, and thus to each and every part regardless of who wrote it.

Thus, it is not the intent of this section to claim rights or contest your rights to work written entirely by you; rather, the intent is to exercise the right to control the distribution of derivative or collective works based on the Library.

In addition, mere aggregation of another work not based on the Library with the Library (or with a work based on the Library) on a volume of a storage or distribution medium does not bring the other work under the scope of this License.

3. You may opt to apply the terms of the ordinary GNU General Public License instead of this License to a given copy of the Library. To do this, you must alter all the notices that refer to this License, so that they refer to the ordinary GNU General Public License, version 2, instead of to this License. (If a newer version than version 2 of the ordinary GNU General Public License has appeared, then you can specify that version instead if you wish.) Do not make any other change in these notices.

Once this change is made in a given copy, it is irreversible for that copy, so the ordinary GNU General Public License applies to all subsequent copies and derivative works made from that copy.

This option is useful when you wish to copy part of the code of the Library into a program that is not a library.

4. You may copy and distribute the Library (or a portion or derivative of it, under Section 2) in object code or executable form under the terms of Sections 1 and 2 above provided that you accompany it with the complete corresponding machine-readable source code, which must be distributed under the terms of Sections 1 and 2 above on a medium customarily used for software interchange.

If distribution of object code is made by offering access to copy from a designated place, then offering equivalent access to copy the source code from the same place satisfies the requirement to distribute the source code, even though third parties are not compelled to copy the source along with the object code.

5. A program that contains no derivative of any portion of the Library, but is designed to work with the Library by being compiled or linked with it, is called a "work that uses the Library". Such a work, in isolation, is not a derivative work of the Library, and therefore falls outside the scope of this License.

However, linking a "work that uses the Library" with the Library creates an executable that is a derivative of the Library (because it contains portions of the Library), rather than a "work that uses the library". The executable is therefore covered by this License. Section 6 states terms for distribution of such executables.

When a "work that uses the Library" uses material from a header file that is part of the Library, the object code for the work may be a derivative work of the Library even though the source code is not. Whether this is true is especially significant if the work can be linked without the Library, or if the work is itself a library. The threshold for this to be true is not precisely defined by law.

If such an object file uses only numerical parameters, data structure layouts and accessors, and small macros and small inline functions (ten lines or less in length), then the use of the object file is unrestricted, regardless of whether it is legally a derivative work. (Executables containing this object code plus portions of the Library will still fall under Section 6.)

Otherwise, if the work is a derivative of the Library, you may distribute the object code for the work under the terms of Section 6. Any executables containing that work also fall under Section 6, whether or not they are linked directly with the Library itself.

6. As an exception to the Sections above, you may also combine or link a "work that uses the Library" with the Library to produce a work containing portions of the Library, and distribute that work under terms of your choice, provided that the terms permit modification of the work for the customer's own use and reverse engineering for debugging such modifications.

You must give prominent notice with each copy of the work that the Library is used in it and that the Library and its use are covered by this License. You must supply a copy of this License. If the work during execution displays copyright notices, you must include the copyright notice for the Library among them, as well as a reference directing the user to the copy of this License. Also, you must do one of these things:

- a) Accompany the work with the complete corresponding machine-readable source code for the Library including whatever changes were used in the work (which must be distributed under Sections 1 and 2 above); and, if the work is an executable linked with the Library, with the complete machine-readable "work that uses the Library", as object code and/or source code, so that the user can modify the Library and then relink to produce a modified executable containing the modified Library. (It is understood that the user who changes the contents of definitions files in the Library will not necessarily be able to recompile the application to use the modified definitions.)
- b) Use a suitable shared library mechanism for linking with the Library. A suitable mechanism is one that (1) uses at run time a copy of the library already present on the user's computer system, rather than copying library functions into the executable, and (2) will operate properly with a modified version of the library, if the user installs one, as long as the modified version is interface-compatible with the version that the work was made with.
- c) Accompany the work with a written offer, valid for at least three years, to give the same user the materials specified in Subsection 6a, above, for a charge no more than the cost of performing this distribution.
- d) If distribution of the work is made by offering access to copy from a designated place, offer equivalent access to copy the above specified materials from the same place.
- e) Verify that the user has already received a copy of these materials or that you have already sent this user a copy.

For an executable, the required form of the "work that uses the Library" must include any data and utility programs needed for reproducing the executable from it. However, as a special exception, the materials to be distributed need not include anything that is normally distributed (in either source or binary form) with the major components (compiler, kernel, and so on) of the operating system on which the executable runs, unless that component itself accompanies the executable.

It may happen that this requirement contradicts the license restrictions of other proprietary libraries that do not normally accompany the operating system. Such a contradiction means you cannot use both them and the Library together in an executable that you distribute.

7. You may place library facilities that are a work based on the Library side-by-side in a single library together with other library facilities not covered by this License, and distribute such a combined library, provided that the separate distribution of the work based on the Library and of the other library facilities is otherwise permitted, and provided that you do these two things:

- a) Accompany the combined library with a copy of the same work based on the Library, uncombined with any other library facilities. This must be distributed under the terms of the Sections above.
- b) Give prominent notice with the combined library of the fact that part of it is a work based on the Library, and explaining where to find the accompanying uncombined form of the same work.

8. You may not copy, modify, sublicense, link with, or distribute the Library except as expressly provided under this License. Any attempt otherwise to copy, modify, sublicense, link with, or distribute the Library is void, and will automatically terminate your rights under this License. However, parties who have received copies, or rights, from you under this License will not have their licenses terminated so long as such parties remain in full compliance.

9. You are not required to accept this License, since you have not signed it. However, nothing else grants you permission to modify or distribute the Library or its derivative works. These actions are prohibited by law if you do not accept this License. Therefore, by modifying or distributing the Library (or any work based on the Library), you indicate your acceptance of this License to do so, and all its terms and conditions for copying, distributing or modifying the Library or works based on it.
10. Each time you redistribute the Library (or any work based on the Library), the recipient automatically receives a license from the original licensor to copy, distribute, link with or modify the Library subject to these terms and conditions. You may not impose any further restrictions on the recipients' exercise of the rights granted herein. You are not responsible for enforcing compliance by third parties with this License.
11. If, as a consequence of a court judgment or allegation of patent infringement or for any other reason (not limited to patent issues), conditions are imposed on you (whether by court order, agreement or otherwise) that contradict the conditions of this License, they do not excuse you from the conditions of this License. If you cannot distribute so as to satisfy simultaneously your obligations under this License and any other pertinent obligations, then as a consequence you may not distribute the Library at all. For example, if a patent license would not permit royalty-free redistribution of the Library by all those who receive copies directly or indirectly through you, then the only way you could satisfy both it and this License would be to refrain entirely from distribution of the Library.

If any portion of this section is held invalid or unenforceable under any particular circumstance, the balance of the section is intended to apply, and the section as a whole is intended to apply in other circumstances.

It is not the purpose of this section to induce you to infringe any patents or other property right claims or to contest validity of any such claims; this section has the sole purpose of protecting the integrity of the free software distribution system which is implemented by public license practices. Many people have made generous contributions to the wide range of software distributed through that system in reliance on consistent application of that system; it is up to the author/donor to decide if he or she is willing to distribute software through any other system and a licensee cannot impose that choice.

This section is intended to make thoroughly clear what is believed to be a consequence of the rest of this License.

12. If the distribution and/or use of the Library is restricted in certain countries either by patents or by copyrighted interfaces, the original copyright holder who places the Library under this License may add an explicit geographical distribution limitation excluding those countries, so that distribution is permitted only in or among countries not thus excluded. In such case, this License incorporates the limitation as if written in the body of this License.
13. The Free Software Foundation may publish revised and/or new versions of the Lesser General Public License from time to time. Such new versions will be similar in spirit to the present version, but may differ in detail to address new problems or concerns.

Each version is given a distinguishing version number. If the Library specifies a version number of this License which applies to it and "any later version", you have the option of following the terms and conditions either of that version or of any later version published by the Free Software Foundation. If the Library does not specify a license version number, you may choose any version ever published by the Free Software Foundation.

14. If you wish to incorporate parts of the Library into other free programs whose distribution conditions are incompatible with these, write to the author to ask for permission. For software which is copyrighted by the Free Software Foundation, write to the Free Software Foundation; we sometimes make exceptions for this. Our decision will be guided by the two goals of preserving the free status of all derivatives of our free software and of promoting the sharing and reuse of software generally.

NO WARRANTY

15. BECAUSE THE LIBRARY IS LICENSED FREE OF CHARGE, THERE IS NO WARRANTY FOR THE LIBRARY, TO THE EXTENT PERMITTED BY APPLICABLE LAW. EXCEPT WHEN OTHERWISE STATED IN WRITING THE COPYRIGHT HOLDERS AND/OR OTHER PARTIES PROVIDE THE LIBRARY "AS IS" WITHOUT WARRANTY OF ANY KIND, EITHER EXPRESSED OR IMPLIED, INCLUDING, BUT NOT LIMITED TO, THE IMPLIED WARRANTIES OF MERCHANTABILITY AND FITNESS FOR A PARTICULAR PURPOSE. THE ENTIRE RISK AS TO THE QUALITY AND PERFORMANCE OF THE LIBRARY IS WITH YOU. SHOULD THE LIBRARY PROVE DEFECTIVE, YOU ASSUME THE COST OF ALL NECESSARY SERVICING, REPAIR OR CORRECTION.
16. IN NO EVENT UNLESS REQUIRED BY APPLICABLE LAW OR AGREED TO IN WRITING WILL ANY COPYRIGHT HOLDER, OR ANY OTHER PARTY WHO MAY MODIFY AND/OR REDISTRIBUTE THE LIBRARY AS PERMITTED ABOVE, BE LIABLE TO YOU FOR DAMAGES, INCLUDING ANY GENERAL, SPECIAL, INCIDENTAL OR CONSEQUENTIAL DAMAGES ARISING OUT OF THE USE OR INABILITY TO USE THE LIBRARY (INCLUDING BUT NOT LIMITED TO LOSS OF DATA OR DATA BEING RENDERED INACCURATE OR LOSSES SUSTAINED BY YOU OR THIRD PARTIES OR A FAILURE OF THE LIBRARY TO OPERATE WITH ANY OTHER SOFTWARE), EVEN IF SUCH HOLDER OR OTHER PARTY HAS BEEN ADVISED OF THE POSSIBILITY OF SUCH DAMAGES.

END OF TERMS AND CONDITIONS

How to Apply These Terms to Your New Libraries

If you develop a new library, and you want it to be of the greatest possible use to the public, we recommend making it free software that everyone can redistribute and change. You can do so by permitting redistribution under these terms (or, alternatively, under the terms of the ordinary General Public License).

To apply these terms, attach the following notices to the library. It is safest to attach them to the start of each source file to most effectively convey the exclusion of warranty; and each file should have at least the "copyright" line and a pointer to where the full notice is found.

```
<one line to give the library's name and a brief idea of what it does.> Copyright (C)
<year> <name of author>
```

This library is free software; you can redistribute it and/or modify it under the terms of the GNU Lesser General Public License as published by the Free Software Foundation; either version 2 of the License, or (at your option) any later version.

This library is distributed in the hope that it will be useful, but WITHOUT ANY WARRANTY; without even the implied warranty of MERCHANTABILITY or FITNESS FOR A PARTICULAR PURPOSE. See the GNU Lesser General Public License for more details.

You should have received a copy of the GNU Lesser General Public License along with this library; if not, write to the Free Software Foundation, Inc., 59 Temple Place, Suite 330, Boston, MA 02111-1307 USA

Also add information on how to contact you by electronic and paper mail.

You should also get your employer (if you work as a programmer) or your school, if any, to sign a "copyright disclaimer" for the library, if necessary. Here is a sample; alter the names:

```
Yoyodyne, Inc., hereby disclaims all copyright interest in the library 'Frob' (a
library for tweaking knobs) written by James Random Hacker.
```

```
<signature of Ty Coon>, 1 April 1990 Ty Coon, President of Vice
```

That's all there is to it!

■ About Fusion

DirectFB Fusion kernel module: introduction and API

by Niels Roest

Copyright (C) 2009 Niels Roest

This documentation is free software; you can redistribute it and/or modify it under the terms of the GNU General Public License as published by the Free Software Foundation; either version 2 of the License, or (at your option) any later version.

This program is distributed in the hope that it will be useful, but WITHOUT ANY WARRANTY; without even the implied warranty of MERCHANTABILITY or FITNESS FOR A PARTICULAR PURPOSE. See the GNU General Public License for more details.

You should have received a copy of the GNU General Public License along with this program; if not, write to the Free Software Foundation, Inc., 59 Temple Place, Suite 330, Boston, MA 02111-1307 USA

For more details see the ?le COPYING in the source distribution of Linux.

■ About openssl

Copyright (C) 1998-2008 The OpenSSL Project. All rights reserved.

Redistribution and use in source and binary forms, with or without modification, are permitted provided that the following conditions are met:

1. Redistributions of source code must retain the above copyright notice, this list of conditions and the following disclaimer.
2. Redistributions in binary form must reproduce the above copyright notice, this list of conditions and the following disclaimer in the documentation and/or other materials provided with the distribution.
3. All advertising materials mentioning features or use of this software must display the following acknowledgment:
"This product includes software developed by the OpenSSL Project for use in the OpenSSL Toolkit. (<http://www.openssl.org/>)"
4. The names "OpenSSL Toolkit" and "OpenSSL Project" must not be used to endorse or promote products derived from this software without prior written permission. For written permission, please contact openssl-core@openssl.org.
5. Products derived from this software may not be called "OpenSSL" nor may "OpenSSL" appear in their names without prior written permission of the OpenSSL Project.
6. Redistributions of any form whatsoever must retain the following acknowledgment:
"This product includes software developed by the OpenSSL Project for use in the OpenSSL Toolkit (<http://www.openssl.org/>)"

THIS SOFTWARE IS PROVIDED BY THE OpenSSL PROJECT "AS IS" AND ANY EXPRESSED OR IMPLIED WARRANTIES, INCLUDING, BUT NOT LIMITED TO, THE IMPLIED WARRANTIES OF MERCHANTABILITY AND FITNESS FOR A PARTICULAR PURPOSE ARE DISCLAIMED. IN NO EVENT SHALL THE OpenSSL PROJECT OR ITS CONTRIBUTORS BE LIABLE FOR ANY DIRECT, INDIRECT, INCIDENTAL, SPECIAL, EXEMPLARY, OR CONSEQUENTIAL DAMAGES (INCLUDING, BUT NOT LIMITED TO, PROCUREMENT OF SUBSTITUTE GOODS OR SERVICES; LOSS OF USE, DATA, OR PROFITS; OR BUSINESS INTERRUPTION) HOWEVER CAUSED AND ON ANY THEORY OF LIABILITY, WHETHER IN CONTRACT, STRICT LIABILITY, OR TORT (INCLUDING NEGLIGENCE OR OTHERWISE) ARISING IN ANY WAY OUT OF THE USE OF THIS SOFTWARE, EVEN IF ADVISED OF THE POSSIBILITY OF SUCH DAMAGE.

This product includes cryptographic software written by Eric Young (ey@cryptsoft.com). This product includes software written by Tim Hudson (tjh@cryptsoft.com).

Original SSLeay License

Copyright (C) 1995-1998 Eric Young (eay@cryptsoft.com) All rights reserved.
This package is an SSL implementation written by Eric Young (eay@cryptsoft.com).
The implementation was written so as to conform with Netscapes SSL.
This library is free for commercial and non-commercial use as long as the following conditions are adhered to. The following conditions apply to all code found in this distribution, be it the RC4, RSA, lhash, DES, etc., code; not just the SSL code. The SSL documentation included with this distribution is covered by the same copyright terms except that the holder is Tim Hudson (tjh@cryptsoft.com).
Copyright remains Eric Young's, and as such any Copyright notices in the code are not to be removed. If this package is used in a product, Eric Young should be given attribution as the author of the parts of the library used. This can be in the form of a textual message at program startup or in documentation (online or textual) provided with the package.

Redistribution and use in source and binary forms, with or without modification, are permitted provided that the following conditions are met:

1. Redistributions of source code must retain the copyright notice, this list of conditions and the following disclaimer.
2. Redistributions in binary form must reproduce the above copyright notice, this list of conditions and the following disclaimer in the documentation and/or other materials provided with the distribution.
3. All advertising materials mentioning features or use of this software must display the following acknowledgement:
"This product includes cryptographic software written by Eric Young (eay@cryptsoft.com)" The word 'cryptographic' can be left out if the routines from the library being used are not cryptographic related :-).
4. If you include any Windows specific code (or a derivative thereof) from the apps directory (application code) you must include an acknowledgement:
"This product includes software written by Tim Hudson (tjh@cryptsoft.com)"

THIS SOFTWARE IS PROVIDED BY ERIC YOUNG "AS IS" AND ANY EXPRESS OR IMPLIED WARRANTIES, INCLUDING, BUT NOT LIMITED TO, THE IMPLIED WARRANTIES OF MERCHANTABILITY AND FITNESS FOR A PARTICULAR PURPOSE ARE DISCLAIMED. IN NO EVENT SHALL THE AUTHOR OR CONTRIBUTORS BE LIABLE FOR ANY DIRECT, INDIRECT, INCIDENTAL, SPECIAL, EXEMPLARY, OR CONSEQUENTIAL DAMAGES (INCLUDING, BUT NOT LIMITED TO, PROCUREMENT OF SUBSTITUTE GOODS OR SERVICES; LOSS OF USE, DATA, OR PROFITS; OR BUSINESS INTERRUPTION) HOWEVER CAUSED AND ON ANY THEORY OF LIABILITY, WHETHER IN CONTRACT, STRICT LIABILITY, OR TORT (INCLUDING NEGLIGENCE OR OTHERWISE) ARISING IN ANY WAY OUT OF THE USE OF THIS SOFTWARE, EVEN IF ADVISED OF THE POSSIBILITY OF SUCH DAMAGE.

This licence and distribution terms for any publically available version or derivative of this code cannot be changed. i.e. this code cannot simply be copied and put under another distribution licence [including the GNU Public Licence.]

■ About zlib

Copyright notice:

(C) 1995-2004 Jean-loup Gailly and Mark Adler

This software is provided 'as-is', without any express or implied warranty. In no event will the authors be held liable for any damages arising from the use of this software. Permission is granted to anyone to use this software for any purpose, including commercial applications, and to alter it and redistribute it freely, subject to the following restrictions:

1. The origin of this software must not be misrepresented; you must not claim that you wrote the original software. If you use this software in a product, an acknowledgment in the product documentation would be appreciated but is not required.

2. Altered source versions must be plainly marked as such, and must not be misrepresented as being the original software.

3. This notice may not be removed or altered from any source distribution.

Jean-loup Gailly Mark Adler

jloup@gzip.org madler@alumni.caltech.edu

If you use the zlib library in a product, we would appreciate *not* receiving lengthy legal documents to sign. The sources are provided for free but without warranty of any kind. The library has been entirely written by Jean-loup Gailly and Mark Adler; it does not include third-party code.

If you redistribute modified sources, we would appreciate that you include in the file ChangeLog history information documenting your changes. Please read the FAQ for more information on the distribution of modified source versions.

■ About FreeType

The FreeType Project LICENSE

2006-Jan-27

Copyright 1996-2002, 2006 by

David Turner, Robert Wilhelm, and Werner Lemberg

Introduction

The FreeType Project is distributed in several archive packages; some of them may contain, in addition to the FreeType font engine, various tools and contributions which rely on, or relate to, the FreeType Project.

This license applies to all files found in such packages, and which do not fall under their own explicit license. The license affects thus the FreeType font engine, the test programs, documentation and makefiles, at the very least.

This license was inspired by the BSD, Artistic, and IJG (Independent JPEG Group) licenses, which all encourage inclusion and use of free software in commercial and freeware products alike. As a consequence, its main points are that:

- o We don't promise that this software works. However, we will be interested in any kind of bug reports. ('as is' distribution)
- o You can use this software for whatever you want, in parts or full form, without having to pay us. ('royalty-free' usage)
- o You may not pretend that you wrote this software. If you use it, or only parts of it, in a program, you must acknowledge somewhere in your documentation that you have used the FreeType code. ('credits')

We specifically permit and encourage the inclusion of this software, with or without modifications, in commercial products. We disclaim all warranties covering The FreeType Project and assume no liability related to The FreeType Project. Finally, many people asked us for a preferred form for a credit/disclaimer to use in compliance with this license. We thus encourage you to use the following text:

Portions of this software are copyright (C) <year> The FreeType Project (www.freetype.org). All rights reserved.

Please replace <year> with the value from the FreeType version you actually use.

Legal Terms

0. Definitions

Throughout this license, the terms 'package', 'FreeType Project', and 'FreeType archive' refer to the set of files originally distributed by the authors (David Turner, Robert Wilhelm, and Werner Lemberg) as the 'FreeType Project', be they named as alpha, beta or final release.

'You' refers to the licensee, or person using the project, where 'using' is a generic term including compiling the project's source code as well as linking it to form a 'program' or 'executable'. This program is referred to as 'a program using the FreeType engine'. This license applies to all files distributed in the original FreeType Project, including all source code, binaries and documentation, unless otherwise stated in the file in its original, unmodified form as distributed in the original archive. If you are unsure whether or not a particular file is covered by this license, you must contact us to verify this.

The FreeType Project is copyright (C) 1996-2000 by David Turner, Robert Wilhelm, and Werner Lemberg. All rights reserved except as specified below.

1. No Warranty

THE FREETYPE PROJECT IS PROVIDED 'AS IS' WITHOUT WARRANTY OF ANY KIND, EITHER EXPRESS OR IMPLIED, INCLUDING, BUT NOT LIMITED TO, WARRANTIES OF MERCHANTABILITY AND FITNESS FOR A PARTICULAR PURPOSE. IN NO EVENT WILL ANY OF THE AUTHORS OR COPYRIGHT HOLDERS BE LIABLE FOR ANY DAMAGES CAUSED BY THE USE OR THE INABILITY TO USE, OF THE FREETYPE PROJECT.

2. Redistribution

This license grants a worldwide, royalty-free, perpetual and irrevocable right and license to use, execute, perform, compile, display, copy, create derivative works of, distribute and sublicense the FreeType Project (in both source and object code forms) and derivative works thereof for any purpose; and to authorize others to exercise some or all of the rights granted herein, subject to the following conditions:

- o Redistribution of source code must retain this license file ('FTL.TXT') unaltered; any additions, deletions or changes to the original files must be clearly indicated in accompanying documentation. The copyright notices of the unaltered, original files must be preserved in all copies of source files.
- o Redistribution in binary form must provide a disclaimer that states that the software is based in part of the work of the FreeType Team, in the distribution documentation. We also encourage you to put an URL to the FreeType web page in your documentation, though this isn't mandatory.

These conditions apply to any software derived from or based on the FreeType Project, not just the unmodified files. If you use our work, you must acknowledge us. However, no fee need be paid to us.

3. Advertising

Neither the FreeType authors and contributors nor you shall use the name of the other for commercial, advertising, or promotional purposes without specific prior written permission.

We suggest, but do not require, that you use one or more of the following phrases to refer to this software in your documentation or advertising materials: 'FreeType Project', 'FreeType Engine', 'FreeType library', or 'FreeType Distribution'.

As you have not signed this license, you are not required to accept it. However, as the FreeType Project is copyrighted material, only this license, or another one contracted with the authors, grants you the right to use, distribute, and modify it. Therefore, by using, distributing, or modifying the FreeType Project, you indicate that you understand and accept all the terms of this license.

4. Contacts

There are two mailing lists related to FreeType:

o freetype@nongnu.org

Discusses general use and applications of FreeType, as well as future and wanted additions to the library and distribution. If you are looking for support, start in this list if you haven't found anything to help you in the documentation.

o freetype-devel@nongnu.org

Discusses bugs, as well as engine internals, design issues, specific licenses, porting, etc. Our home page can be found at <http://www.freetype.org>

■ About Expat

Copyright (C) 1998, 1999, 2000 Thai Open Source Software Center Ltd
and Clark Cooper

Copyright (C) 2001, 2002, 2003, 2004, 2005, 2006 Expat maintainers.

Permission is hereby granted, free of charge, to any person obtaining a copy of this software and associated documentation files (the "Software"), to deal in the Software without restriction, including without limitation the rights to use, copy, modify, merge, publish, distribute, sublicense, and/or sell copies of the Software, and to permit persons to whom the Software is furnished to do so, subject to the following conditions:

The above copyright notice and this permission notice shall be included in all copies or substantial portions of the Software.

THE SOFTWARE IS PROVIDED "AS IS", WITHOUT WARRANTY OF ANY KIND, EXPRESS OR IMPLIED, INCLUDING BUT NOT LIMITED TO THE WARRANTIES OF MERCHANTABILITY, FITNESS FOR A PARTICULAR PURPOSE AND NONINFRINGEMENT. IN NO EVENT SHALL THE AUTHORS OR COPYRIGHT HOLDERS BE LIABLE FOR ANY CLAIM, DAMAGES OR OTHER LIABILITY, WHETHER IN AN ACTION OF CONTRACT, TORT OR OTHERWISE, ARISING FROM, OUT OF OR IN CONNECTION WITH THE SOFTWARE OR THE USE OR OTHER DEALINGS IN THE SOFTWARE.

■ About cURL

COPYRIGHT AND PERMISSION NOTICE

Copyright (C) 1996 - 2009, Daniel Stenberg, <daniel@haxx.se>.

All rights reserved.

Permission to use, copy, modify, and distribute this software for any purpose with or without fee is hereby granted, provided that the above copyright notice and this permission notice appear in all copies.

THE SOFTWARE IS PROVIDED "AS IS", WITHOUT WARRANTY OF ANY KIND, EXPRESS OR IMPLIED, INCLUDING BUT NOT LIMITED TO THE WARRANTIES OF MERCHANTABILITY, FITNESS FOR A PARTICULAR PURPOSE AND NONINFRINGEMENT OF THIRD PARTY RIGHTS. IN NO EVENT SHALL THE AUTHORS OR COPYRIGHT HOLDERS BE LIABLE FOR ANY CLAIM, DAMAGES OR OTHER LIABILITY, WHETHER IN AN ACTION OF CONTRACT, TORT OR OTHERWISE, ARISING FROM, OUT OF OR IN CONNECTION WITH THE SOFTWARE OR THE USE OR OTHER DEALINGS IN THE SOFTWARE.

Except as contained in this notice, the name of a copyright holder shall not be used in advertising or otherwise to promote the sale, use or other dealings in this Software without prior written authorization of the copyright holder.

■ About Independent JPEG group

The Independent JPEG Group's JPEG software

README for release 7 of 27-Jun-2009

This distribution contains the seventh public release of the Independent JPEG Group's free JPEG software. You are welcome to redistribute this software and to use it for any purpose, subject to the conditions under LEGAL ISSUES, below.

This software is the work of Tom Lane, Guido Vollbeding, Philip Gladstone, Bill Allombert, Jim Boucher, Lee Crocker, Bob Friesenbahn, Ben Jackson, Julian Minguillon, Luis Ortiz, George Phillips, Davide Rossi, Ge' Weijers, and other members of the Independent JPEG Group.

IJG is not affiliated with the official ISO JPEG standards committee.

DOCUMENTATION ROADMAP

This file contains the following sections:

OVERVIEW	General description of JPEG and the IJG software.
LEGAL ISSUES	Copyright, lack of warranty, terms of distribution.
REFERENCES	Where to learn more about JPEG.
ARCHIVE LOCATIONS	Where to find newer versions of this software.
ACKNOWLEDGMENTS	Special thanks.
FILE FORMAT WARS	Software *not* to get.
TO DO	Plans for future IJG releases.

Other documentation files in the distribution are:

User documentation:

install.txt	How to configure and install the IJG software.
usage.txt	Usage instructions for cjpeg, djpeg, jpegtran, rdjpgcom, and wrjpgcom.
*.1	Unix-style man pages for programs (same info as usage.txt).
wizard.txt	Advanced usage instructions for JPEG wizards only.
change.log	Version-to-version change highlights.

Programmer and internal documentation:

libjpeg.txt	How to use the JPEG library in your own programs.
example.c	Sample code for calling the JPEG library.
structure.txt	Overview of the JPEG library's internal structure.
filelist.txt	Road map of IJG files.
codersules.txt	Coding style rules --- please read if you contribute code.

Please read at least the files install.txt and usage.txt. Some information can also be found in the JPEG FAQ (Frequently Asked Questions) article. See ARCHIVE LOCATIONS below to find out where to obtain the FAQ article.

If you want to understand how the JPEG code works, we suggest reading one or more of the REFERENCES, then looking at the documentation files (in roughly the order listed) before diving into the code.

OVERVIEW

This package contains C software to implement JPEG image encoding, decoding, and transcoding. JPEG (pronounced "jay-peg") is a standardized compression method for full-color and gray-scale images.

This software implements JPEG baseline, extended-sequential, and progressive compression processes. Provision is made for supporting all variants of these processes, although some uncommon parameter settings aren't implemented yet. We have made no provision for supporting the hierarchical or lossless processes defined in the standard.

We provide a set of library routines for reading and writing JPEG image files, plus two sample applications "cjpeg" and "djpeg", which use the library to perform conversion between JPEG and some other popular image file formats. The library is intended to be reused in other applications.

In order to support file conversion and viewing software, we have included considerable functionality beyond the bare JPEG coding/decoding capability; for example, the color quantization modules are not strictly part of JPEG decoding, but they are essential for output to colormapped file formats or colormapped displays. These extra functions can be compiled out of the library if not required for a particular application.

We have also included "jpegtran", a utility for lossless transcoding between different JPEG processes, and "rdjpgcom" and "wrjpgcom", two simple applications for inserting and extracting textual comments in JFIF files.

The emphasis in designing this software has been on achieving portability and flexibility, while also making it fast enough to be useful. In particular, the software is not intended to be read as a tutorial on JPEG. (See the REFERENCES section for introductory material.) Rather, it is intended to be reliable, portable, industrial-strength code. We do not claim to have achieved that goal in every aspect of the software, but we strive for it.

We welcome the use of this software as a component of commercial products. No royalty is required, but we do ask for an acknowledgement in product documentation, as described under LEGAL ISSUES.

LEGAL ISSUES

In plain English:

1. We don't promise that this software works. (But if you find any bugs, please let us know!)
2. You can use this software for whatever you want. You don't have to pay us.
3. You may not pretend that you wrote this software. If you use it in a program, you must acknowledge somewhere in your documentation that you've used the IJG code.

In legalese:

The authors make NO WARRANTY or representation, either express or implied, with respect to this software, its quality, accuracy, merchantability, or fitness for a particular purpose. This software is provided "AS IS", and you, its user, assume the entire risk as to its quality and accuracy.

This software is copyright (C) 1991-2009, Thomas G. Lane, Guido Vollbeding.

All Rights Reserved except as specified below.

Permission is hereby granted to use, copy, modify, and distribute this software (or portions thereof) for any purpose, without fee, subject to these conditions:

- (1) If any part of the source code for this software is distributed, then this README file must be included, with this copyright and no-warranty notice unaltered; and any additions, deletions, or changes to the original files must be clearly indicated in accompanying documentation.
- (2) If only executable code is distributed, then the accompanying documentation must state that "this software is based in part on the work of the Independent JPEG Group".
- (3) Permission for use of this software is granted only if the user accepts full responsibility for any undesirable consequences; the authors accept NO LIABILITY for damages of any kind.

These conditions apply to any software derived from or based on the IJG code, not just to the unmodified library. If you use our work, you ought to acknowledge us.

Permission is NOT granted for the use of any IJG author's name or company name in advertising or publicity relating to this software or products derived from it. This software may be referred to only as "the Independent JPEG Group's software".

We specifically permit and encourage the use of this software as the basis of commercial products, provided that all warranty or liability claims are assumed by the product vendor.

ansi2knr.c is included in this distribution by permission of L. Peter Deutsch, sole proprietor of its copyright holder, Aladdin Enterprises of Menlo Park, CA. ansi2knr.c is NOT covered by the above copyright and conditions, but instead by the usual distribution terms of the Free Software Foundation; principally, that you must include source code if you redistribute it. (See the file ansi2knr.c for full details.) However, since ansi2knr.c is not needed as part of any program generated from the IJG code, this does not limit you more than the foregoing paragraphs do.

The Unix configuration script "configure" was produced with GNU Autoconf. It is copyright by the Free Software Foundation but is freely distributable. The same holds for its supporting scripts (config.guess, config.sub, ltmain.sh). Another support script, install-sh, is copyright by X Consortium but is also freely distributable.

The IJG distribution formerly included code to read and write GIF files. To avoid entanglement with the Unisys LZW patent, GIF reading support has been removed altogether, and the GIF writer has been simplified to produce "uncompressed GIFs". This technique does not use the LZW algorithm; the resulting GIF files are larger than usual, but are readable by all standard GIF decoders.

We are required to state that

"The Graphics Interchange Format(c) is the Copyright property of
CompuServe Incorporated. GIF(sm) is a Service Mark property of
CompuServe Incorporated."

REFERENCES

We recommend reading one or more of these references before trying to understand the innards of the JPEG software.

The best short technical introduction to the JPEG compression algorithm is

Wallace, Gregory K. "The JPEG Still Picture Compression Standard",

(Adjacent articles in that issue discuss MPEG motion picture compression, applications of JPEG, and related topics.) If you don't have the CACM issue handy, a PostScript file containing a revised version of Wallace's article is available at <http://www.iijg.org/files/wallace.ps.gz>. The file (actually a preprint for an article that appeared in IEEE Trans. Consumer Electronics) omits the sample images that appeared in CACM, but it includes corrections and some added material. Note: the Wallace article is copyright ACM and IEEE, and it may not be used for commercial purposes.

A somewhat less technical, more leisurely introduction to JPEG can be found in "The Data Compression Book" by Mark Nelson and Jean-loup Gailly, published by M&T Books (New York), 2nd ed. 1996, ISBN 1-55851-434-1. This book provides good explanations and example C code for a multitude of compression methods including JPEG. It is an excellent source if you are comfortable reading C code but don't know much about data compression in general. The book's JPEG sample code is far from industrial-strength, but when you are ready to look at a full implementation, you've got one here...

The best currently available description of JPEG is the textbook "JPEG Still Image Data Compression Standard" by William B. Pennebaker and Joan L. Mitchell, published by Van Nostrand Reinhold, 1993, ISBN 0-442-01272-1. Price US\$59.95, 638 pp. The book includes the complete text of the ISO JPEG standards (DIS 10918-1 and draft DIS 10918-2).

Although this is by far the most detailed and comprehensive exposition of JPEG publicly available, we point out that it is still missing an explanation of the most essential properties and algorithms of the underlying DCT technology. If you think that you know about DCT-based JPEG after reading this book, then you are in delusion. The real fundamentals and corresponding potential of DCT-based JPEG are not publicly known so far, and that is the reason for all the mistaken developments taking place in the image coding domain.

The original JPEG standard is divided into two parts, Part 1 being the actual specification, while Part 2 covers compliance testing methods. Part 1 is titled "Digital Compression and Coding of Continuous-tone Still Images, Part 1: Requirements and guidelines" and has document numbers ISO/IEC IS 10918-1, ITU-T T.81. Part 2 is titled "Digital Compression and Coding of Continuous-tone Still Images, Part 2: Compliance testing" and has document numbers ISO/IEC IS 10918-2, ITU-T T.83. The JPEG standard does not specify all details of an interchangeable file format. For the omitted details we follow the "JFIF" conventions, revision 1.02. A copy of the JFIF spec is available from:

Literature Department
C-Cube Microsystems, Inc.
1778 McCarthy Blvd.
Milpitas, CA 95035
phone (408) 944-6300, fax (408) 944-6314

A PostScript version of this document is available at <http://www.iijg.org/files/jfif.ps.gz>. There is also a plain text version at <http://www.iijg.org/files/jfif.txt.gz>, but it is missing the figures.

The TIFF 6.0 file format specification can be obtained by FTP from <ftp://ftp.sgi.com/graphics/tiff/TIFF6.ps.gz>. The JPEG incorporation scheme found in the TIFF 6.0 spec of 3-June-92 has a number of serious problems. IJG does not recommend use of the TIFF 6.0 design (TIFF Compression tag 6). Instead, we recommend the JPEG design proposed by TIFF Technical Note #2 (Compression tag 7). Copies of this Note can be obtained from <http://www.iijg.org/files/>. It is expected that the next revision of the TIFF spec will replace the 6.0 JPEG design with the Note's design. Although IJG's own code does not support TIFF/JPEG, the free libtiff library uses our library to implement TIFF/JPEG per the Note.

ARCHIVE LOCATIONS

The "official" archive site for this software is www.iijg.org. The most recent released version can always be found there in directory "files". This particular version will be archived as <http://www.iijg.org/files/jpegsrc.v7.tar.gz>, and in Windows-compatible "zip" archive format as <http://www.iijg.org/files/jpegsrc7.zip>.

The JPEG FAQ (Frequently Asked Questions) article is a source of some general information about JPEG. It is available on the World Wide Web at <http://www.faqs.org/faqs/jpeg-faq/> and other news.answers archive sites, including the official news.answers archive at [rtfm.mit.edu: ftp://rtfm.mit.edu/pub/usenet/news.answers/jpeg-faq/](http://rtfm.mit.edu/pub/usenet/news.answers/jpeg-faq/). If you don't have Web or FTP access, send e-mail to mail-server@rtfm.mit.edu with body

send usenet/news.answers/jpeg-faq/part1
send usenet/news.answers/jpeg-faq/part2

ACKNOWLEDGMENTS

Thank to Juergen Bruder of the Georg-Cantor-Organization at the Martin-Luther-University Halle for providing me with a copy of the common DCT algorithm article, only to find out that I had come to the same result in a more direct and comprehensible way with a more generative approach.

Thank to Istvan Sebestyen and Joan L. Mitchell for inviting me to the ITU JPEG (Study Group 16) meeting in Geneva, Switzerland.

Thank to Thomas Wiegand and Gary Sullivan for inviting me to the Joint Video Team (MPEG & ITU) meeting in Geneva, Switzerland.

Thank to John Korejwa and Massimo Ballerini for inviting me to fruitful consultations in Boston, MA and Milan, Italy.

Thank to Hendrik Elstner, Roland Fassauer, and Simone Zuck for corresponding business development.

Thank to Nico Zschach and Dirk Stelling of the technical support team at the Digital Images company in Halle for providing me with extra equipment for configuration tests.

Thank to Richard F. Lyon (then of Foveon Inc.) for fruitful communication about JPEG configuration in Sigma Photo Pro software.

Last but not least special thank to Thomas G. Lane for the original design and development of this singular software package.

FILE FORMAT WARS

The ISO JPEG standards committee actually promotes different formats like JPEG-2000 or JPEG-XR which are incompatible with original DCT-based JPEG and which are based on faulty technologies. IJG therefore does not and will not support such momentary mistakes (see REFERENCES). We have little or no sympathy for the promotion of these formats. Indeed, one of the original reasons for developing this free software was to help force convergence on common, interoperable format standards for JPEG files. Don't use an incompatible file format! (In any case, our decoder will remain capable of reading existing JPEG image files indefinitely.)

TO DO

v7 is basically just a necessary interim release, paving the way for a major breakthrough in image coding technology with the next v8 package which is scheduled for release in the year 2010.

Please send bug reports, offers of help, etc. to jpeg-info@jpegclub.org.

■ About International Components for Unicode

ICU License - ICU 1.8.1 and later

COPYRIGHT AND PERMISSION NOTICE

Copyright (C) 1995-2003 International Business Machines Corporation and others
All rights reserved.

Permission is hereby granted, free of charge, to any person obtaining a copy of this software and associated documentation files (the "Software"), to deal in the Software without restriction, including without limitation the rights to use, copy, modify, merge, publish, distribute, and/or sell copies of the Software, and to permit persons to whom the Software is furnished to do so, provided that the above copyright notice(s) and this permission notice appear in all copies of the Software and that both the above copyright notice(s) and this permission notice appear in supporting documentation.

THE SOFTWARE IS PROVIDED "AS IS", WITHOUT WARRANTY OF ANY KIND, EXPRESS OR IMPLIED, INCLUDING BUT NOT LIMITED TO THE WARRANTIES OF MERCHANTABILITY, FITNESS FOR A PARTICULAR PURPOSE AND NONINFRINGEMENT OF THIRD PARTY RIGHTS. IN NO EVENT SHALL THE COPYRIGHT HOLDER OR HOLDERS INCLUDED IN THIS NOTICE BE LIABLE FOR ANY CLAIM, OR ANY SPECIAL INDIRECT OR CONSEQUENTIAL DAMAGES, OR ANY DAMAGES WHATSOEVER RESULTING FROM LOSS OF USE, DATA OR PROFITS, WHETHER IN AN ACTION OF CONTRACT, NEGLIGENCE OR OTHER TORTIOUS ACTION, ARISING OUT OF OR IN CONNECTION WITH THE USE OR PERFORMANCE OF THIS SOFTWARE.

Except as contained in this notice, the name of a copyright holder shall not be used in advertising or otherwise to promote the sale, use or other dealings in this Software without prior written authorization of the copyright holder.

All trademarks and registered trademarks mentioned herein are the property of their respective owners.

■ About libpng

This copy of the libpng notices is provided for your convenience. In case of any discrepancy between this copy and the notices in the file png.h that is included in the libpng distribution, the latter shall prevail.

COPYRIGHT NOTICE, DISCLAIMER, and LICENSE:

If you modify libpng you may insert additional notices immediately following this sentence.

libpng versions 1.2.6, August 15, 2004, through 1.2.35, February 14, 2009, are Copyright (C) 2004, 2006-2008 Glenn Randers-Pehrson, and are distributed according to the same disclaimer and license as libpng-1.2.5 with the following individual added to the list of Contributing Authors

Cosmin Truta

libpng versions 1.0.7, July 1, 2000, through 1.2.5 - October 3, 2002, are Copyright (C) 2000-2002 Glenn Randers-Pehrson, and are distributed according to the same disclaimer and license as libpng-1.0.6 with the following individuals added to the list of Contributing Authors

Simon-Pierre Cadieux

Eric S. Raymond

Gilles Vollant

and with the following additions to the disclaimer:

There is no warranty against interference with your enjoyment of the library or against infringement. There is no warranty that our efforts or the library will fulfill any of your particular purposes or needs. This library is provided with all faults, and the entire risk of satisfactory quality, performance, accuracy, and effort is with the user.

libpng versions 0.97, January 1998, through 1.0.6, March 20, 2000, are Copyright (C) 1998, 1999 Glenn Randers-Pehrson, and are distributed according to the same disclaimer and license as libpng-0.96, with the following individuals added to the list of Contributing Authors:

Tom Lane

Glenn Randers-Pehrson

Willem van Schaik

libpng versions 0.89, June 1996, through 0.96, May 1997, are Copyright (C) 1996, 1997 Andreas Dilger Distributed according to the same disclaimer and license as libpng-0.88, with the following individuals added to the list of Contributing Authors:

John Bowler

Kevin Bracey

Sam Bushell

Magnus Holmgren

Greg Roelofs

Tom Tanner

libpng versions 0.5, May 1995, through 0.88, January 1996, are Copyright (C) 1995, 1996 Guy Eric Schalnat, Group 42, Inc.
For the purposes of this copyright and license, "Contributing Authors" is defined as the following set of individuals:

Andreas Dilger
Dave Martindale
Guy Eric Schalnat
Paul Schmidt
Tim Wegner

The PNG Reference Library is supplied "AS IS". The Contributing Authors and Group 42, Inc. disclaim all warranties, expressed or implied, including, without limitation, the warranties of merchantability and of fitness for any purpose. The Contributing Authors and Group 42, Inc. assume no liability for direct, indirect, incidental, special, exemplary, or consequential damages, which may result from the use of the PNG Reference Library, even if advised of the possibility of such damage. Permission is hereby granted to use, copy, modify, and distribute this source code, or portions hereof, for any purpose, without fee, subject to the following restrictions:

1. The origin of this source code must not be misrepresented.
2. Altered versions must be plainly marked as such and must not be misrepresented as being the original source.
3. This Copyright notice may not be removed or altered from any source or altered source distribution.

The Contributing Authors and Group 42, Inc. specifically permit, without fee, and encourage the use of this source code as a component to supporting the PNG file format in commercial products. If you use this source code in a product, acknowledgment is not required but would be appreciated.

A "png_get_copyright" function is available, for convenient use in "about" boxes and the like:

```
printf("%s",png_get_copyright(NULL));
```

Also, the PNG logo (in PNG format, of course) is supplied in the files "pngbar.png" and "pngbar.jpg (88x31)" and "pngnow.png" (98x31).

Libpng is OSI Certified Open Source Software. OSI Certified Open Source is a certification mark of the Open Source Initiative.

Glenn Randers-Pehrson
glennrp at users.sourceforge.net
February 14, 2009

■ About tinymce

www.sourceforge.net/projects/tinymce

Original code (2.0 and earlier)copyright (C) 2000-2006 Lee Thomason
(www.grinninglizard.com)

This software is provided 'as-is', without any express or implied warranty. In no event will the authors be held liable for any damages arising from the use of this software.

Permission is granted to anyone to use this software for any purpose, including commercial applications, and to alter it and redistribute it freely, subject to the following restrictions:

1. The origin of this software must not be misrepresented; you must not claim that you wrote the original software. If you use this software in a product, an acknowledgment in the product documentation would be appreciated but is not required.
2. Altered source versions must be plainly marked as such, and must not be misrepresented as being the original software.
3. This notice may not be removed or altered from any source distribution.

■ About dtoa and strtod

The author of this software is David M. Gay.

Copyright (C) 1991, 2000, 2001 by Lucent Technologies.

Permission to use, copy, modify, and distribute this software for any purpose without fee is hereby granted, provided that this entire notice is included in all copies of any software which is or includes a copy or modification of this software and in all copies of the supporting documentation for such software.

THIS SOFTWARE IS BEING PROVIDED "AS IS", WITHOUT ANY EXPRESS OR IMPLIED WARRANTY. IN PARTICULAR, NEITHER THE AUTHOR NOR LUCENT MAKES ANY REPRESENTATION OR WARRANTY OF ANY KIND CONCERNING THE MERCHANTABILITY OF THIS SOFTWARE OR ITS FITNESS FOR ANY PARTICULAR PURPOSE.

■ About gSOAP

gSOAP Public License

Version 1.3b

The gSOAP public license is derived from the Mozilla Public License (MPL1.1). The sections that were deleted from the original MPL1.1 text are 1.0.1, 2.1.(c),(d), 2.2.(c),(d), 8.2.(b), 10, and 11.

Section 3.8 was added. The modified sections are 2.1.(b), 2.2.(b), 3.2 (simplified), 3.5 (deleted the last sentence), and 3.6 (simplified).

This license applies to the gSOAP software package, with the exception of the wsdl2h source code located in `gsoap/wsdl`, all code generated by `wsdl2h`, the UDDI source code `gsoap/uddi2`, and the Web server sample source code `samples/webserver`. To use all of the software commercially, a commercial license has to be obtained from www.genivia.com.

1 DEFINITIONS.

1.0.1.

1.1. "Contributor" means each entity that creates or contributes to the creation of Modifications.

1.2. "Contributor Version" means the combination of the Original Code, prior Modifications used by a Contributor, and the Modifications made by that particular Contributor.

1.3. "Covered Code" means the Original Code, or Modifications or the combination of the Original Code, and Modifications, in each case including portions thereof.

1.4. "Electronic Distribution Mechanism" means a mechanism generally accepted in the software development community for the electronic transfer of data.

1.5. "Executable" means Covered Code in any form other than Source Code.

1.6. "Initial Developer" means the individual or entity identified as the Initial Developer in the Source Code notice required by Exhibit A.

1.7. "Larger Work" means a work which combines Covered Code or portions thereof with code not governed by the terms of this License.

1.8. "License" means this document.

1.8.1. "Licensable" means having the right to grant, to the maximum extent possible, whether at the time of the initial grant or subsequently acquired, any and all of the rights conveyed herein.

1.9. "Modifications" means any addition to or deletion from the substance or structure of either the Original Code or any previous Modifications. When Covered Code is released as a series of files, a Modification is: A.

Any addition to or deletion from the contents of a file containing Original Code or previous Modifications. B.

Any new file that contains any part of the Original Code, or previous Modifications.

1.10. "Original Code" means Source Code of computer software code which is described in the Source Code notice required by Exhibit A as Original Code, and which, at the time of its release under this License is not already Covered Code governed by this License.

1.10.1. "Patent Claims" means any patent claim(s), now owned or hereafter acquired, including without limitation, method, process, and apparatus claims, in any patent Licensable by grantor.

<http://www.cs.fsu.edu/~engelen/license.html>

1.11. "Source Code" means the preferred form of the Covered Code for making modifications to it, including all modules it contains, plus any associated interface definition files, scripts used to control compilation and installation of an Executable, or source code differential comparisons against either the Original Code or another well known, available Covered Code of the Contributor's choice. The Source Code can be in a compressed or archival form, provided the appropriate decompression or de-archiving software is widely available for no charge.

1.12. "You" (or "Your") means an individual or a legal entity exercising rights under, and complying with all of the terms of, this License or a future version of this License issued under Section 6.1. For legal entities, "You" includes any entity which controls, is controlled by, or is under common control with You. For purposes of this definition, "control" means (a) the power, direct or indirect, to cause the direction or management of such entity, whether by contract or otherwise, or (b) ownership of more than fifty percent (50%) of the outstanding shares or beneficial ownership of such entity.

2 SOURCE CODE LICENSE.

2.1. The Initial Developer Grant. The Initial Developer hereby grants You a world-wide, royalty-free, non-exclusive license, subject to third party intellectual property claims:

- (a) under intellectual property rights (other than patent or trademark) Licensable by Initial Developer to use, reproduce, modify, display, perform, sublicense and distribute the Original Code (or portions thereof) with or without Modifications, and/or as part of a Larger Work; and
- (b) under patents now or hereafter owned or controlled by Initial Developer, to make, have made, use and sell ("offer to sell and import") the Original Code, Modifications, or portions thereof, but solely to the extent that any such patent is reasonably necessary to enable You to utilize, alone or in combination with other software, the Original Code, Modifications, or any combination or portions thereof.

(c)

(d)

2.2. Contributor Grant.

Subject to third party intellectual property claims, each Contributor hereby grants You a world-wide, royalty-free, non-exclusive license

(a)

under intellectual property rights (other than patent or trademark) Licensable by Contributor, to use, reproduce, modify, display, perform, sublicense and distribute the Modifications created by such Contributor (or portions thereof) either on an unmodified basis, with other Modifications, as Covered Code and/or as part of a Larger Work; and

(b)

under patents now or hereafter owned or controlled by Contributor, to make, have made, use and sell ("offer to sell and import") the Contributor Version (or portions thereof), but solely to the extent that any such patent is reasonably necessary to enable You to utilize, alone or in combination with other software, the Contributor Version (or portions thereof).

(c)

(d)

3 DISTRIBUTION OBLIGATIONS.

3.1. Application of License.

The Modifications which You create or to which You contribute are governed by the terms of this License, including without limitation Section 2.2. The Source Code version of Covered Code may be distributed only under the terms of this License or a future version of this License released under Section 6.1, and You must include a copy of this License with every copy of the Source Code You distribute. You may not offer or impose any terms on any Source Code version that alters or restricts the applicable version of this License or the recipients' rights hereunder. However, You may include an additional document offering the additional rights described in Section 3.5.

3.2. Availability of Source Code.

Any Modification created by You will be provided to the Initial Developer in Source Code form and are subject to the terms of the License.

3.3. Description of Modifications.

You must cause all Covered Code to which You contribute to contain a file documenting the changes You made to create that Covered Code and the date of any change. You must include a prominent statement that the Modification is derived, directly or indirectly, from Original Code provided by the Initial Developer and including the name of the Initial Developer in (a) the Source Code, and (b) in any notice in an Executable version or related documentation in which You describe the origin or ownership of the Covered Code.

3.4. Intellectual Property Matters.

(a) Third Party Claims.

If Contributor has knowledge that a license under a third party's intellectual property rights is required to exercise the rights granted by such Contributor under Sections 2.1 or 2.2, Contributor must include a text file with the Source Code distribution titled "LEGAL" which describes the claim and the party making the claim in sufficient detail that a recipient will know whom to contact. If Contributor obtains such knowledge after the Modification is made available as described in Section 3.2, Contributor shall promptly modify the LEGAL file in all copies Contributor makes available thereafter and shall take other steps (such as notifying appropriate mailing lists or newsgroups) reasonably calculated to inform those who received the Covered Code that new knowledge has been obtained.

(b) Contributor APIs.

If Contributor's Modifications include an application programming interface and Contributor has knowledge of patent licenses which are reasonably necessary to implement that API, Contributor must also include this information in the LEGAL file.

(c) Representations.

Contributor represents that, except as disclosed pursuant to Section 3.4(a) above, Contributor believes that Contributor's Modifications are Contributor's original creation(s) and/or Contributor has sufficient rights to grant the rights conveyed by this License.

3.5. Required Notices.

You must duplicate the notice in Exhibit A in each file of the Source Code. If it is not possible to put such notice in a particular Source Code file due to its structure, then You must include such notice in a location (such as a relevant directory) where a user would be likely to look for such a notice. If You created one or more Modification(s) You may add your name as a Contributor to the notice described in Exhibit A. You must also duplicate this License in any documentation for the Source Code where You describe recipients' rights or ownership rights relating to Covered Code. You may choose to offer, and to charge a fee for, warranty, support, indemnity or liability obligations to one or more recipients of Covered Code. However, You may do so only on Your own behalf, and not on behalf of the Initial Developer or any Contributor.

3.6. Distribution of Executable Versions.

You may distribute Covered Code in Executable form only if the requirements of Section 3.1-3.5 have been met for that Covered Code. You may distribute the Executable version of Covered Code or ownership rights under a license of Your choice, which may contain terms different from this License, provided that You are in compliance with the terms of this License and that the license for the Executable version does not attempt to limit or alter the recipient's rights in the Source Code version from the rights set forth in this License. If You distribute the Executable version under a different license You must make it absolutely clear that any terms which differ from this License are offered by You alone, not by the Initial Developer or any Contributor. If you distribute executable versions containing Covered Code as part of a product, you must reproduce the notice in Exhibit B in the documentation and/or other materials provided with the product.

3.7. Larger Works.

You may create a Larger Work by combining Covered Code with other code not governed by the terms of this License and distribute the Larger Work as a single product. In such a case, You must make sure the requirements of this License are fulfilled for the Covered Code.

3.8. Restrictions.

You may not remove any product identification, copyright, proprietary notices or labels from gSOAP.

4 INABILITY TO COMPLY DUE TO STATUTE OR REGULATION.

If it is impossible for You to comply with any of the terms of this License with respect to some or all of the Covered Code due to statute, judicial order, or regulation then You must: (a) comply with the terms of this License to the maximum extent possible; and (b) describe the limitations and the code they affect. Such description must be included in the LEGAL file described in Section 3.4 and must be included with all distributions of the Source Code, Except to the extent prohibited by statute or regulation, such description must be sufficiently detailed for a recipient of ordinary skill to be able to understand it.

5 APPLICATION OF THIS LICENSE.

This License applies to code to which the Initial Developer has attached the notice in Exhibit A and to related Covered Code.

6 VERSIONS OF THE LICENSE.

6.1. New Versions.

Grantor may publish revised and/or new versions of the License from time to time. Each version will be given a distinguishing version number.

6.2. Effect of New Versions.

Once Covered Code has been published under a particular version of the License, You may always continue to use it under the terms of that version. You may also choose to use such Covered Code under the terms of any subsequent version of the License.

6.3. Derivative Works.

If You create or use a modified version of this License (which you may only do in order to apply it to code which is not already Covered Code governed by this License), You must (a) rename Your license so that the phrase "gSOAP" or any confusingly similar phrase do not appear in your license (except to note that your license differs from this License) and (b) otherwise make it clear that Your version of the license contains terms which differ from the gSOAP Public License. (Filling in the name of the Initial Developer, Original Code or Contributor in the notice described in Exhibit A shall not of themselves be deemed to be modifications of this License.)

7 DISCLAIMER OF WARRANTY.

COVERED CODE IS PROVIDED UNDER THIS LICENSE ON AN "AS IS" BASIS, WITHOUT WARRANTY OF ANY KIND, WHETHER EXPRESS, IMPLIED OR STATUTORY, INCLUDING, WITHOUT LIMITATION, THE IMPLIED WARRANTIES OF MERCHANTABILITY, OF FITNESS FOR A PARTICULAR PURPOSE, NON-INFRINGEMENT OF THIRD PARTY INTELLECTUAL PROPERTY RIGHTS, AND ANY WARRANTY THAT MAY ARISE BY REASON OF TRADE USAGE, CUSTOM, OR COURSE OF DEALING, WITHOUT LIMITING THE FOREGOING, YOU ACKNOWLEDGE THAT THE SOFTWARE IS PROVIDED "AS IS" AND THAT THE AUTHORS DO NOT WARRANT THE SOFTWARE WILL RUN UNINTERRUPTED OR ERROR FREE. LIMITED LIABILITY THE ENTIRE RISK AS TO RESULTS AND PERFORMANCE OF THE SOFTWARE IS ASSUMED BY YOU. UNDER NO CIRCUMSTANCES WILL THE AUTHORS BE LIABLE FOR ANY SPECIAL, INDIRECT, INCIDENTAL, EXEMPLARY OR CONSEQUENTIAL DAMAGES OF ANY KIND OR NATURE WHATSOEVER, WHETHER BASED ON CONTRACT, WARRANTY, TORT (INCLUDING NEGLIGENCE), STRICT LIABILITY OR OTHERWISE, ARISING OUT OF OR IN ANY WAY RELATED TO THE SOFTWARE, EVEN IF THE AUTHORS HAVE BEEN ADVISED ON THE POSSIBILITY OF SUCH DAMAGE OR IF SUCH DAMAGE COULD HAVE BEEN REASONABLY FORESEEN, AND NOTWITHSTANDING ANY FAILURE OF ESSENTIAL PURPOSE OF ANY EXCLUSIVE REMEDY PROVIDED. SUCH LIMITATION ON DAMAGES INCLUDES, BUT IS NOT LIMITED TO, DAMAGES FOR LOSS OF GOODWILL, LOST PROFITS, LOSS OF DATA OR SOFTWARE, WORK STOPPAGE, COMPUTER FAILURE OR MALFUNCTION OR IMPAIRMENT OF OTHER GOODS. IN NO EVENT WILL THE AUTHORS BE LIABLE FOR THE COSTS OF PROCUREMENT OF SUBSTITUTE SOFTWARE OR SERVICES. YOU ACKNOWLEDGE THAT THIS SOFTWARE IS NOT DESIGNED FOR USE IN ON-LINE EQUIPMENT IN HAZARDOUS ENVIRONMENTS SUCH AS OPERATION OF NUCLEAR FACILITIES, AIRCRAFT NAVIGATION OR CONTROL, OR LIFE-CRITICAL APPLICATIONS. THE AUTHORS EXPRESSLY DISCLAIM ANY LIABILITY RESULTING FROM USE OF THE SOFTWARE IN ANY SUCH ON-LINE EQUIPMENT IN HAZARDOUS ENVIRONMENTS AND ACCEPTS NO LIABILITY IN RESPECT OF ANY ACTIONS OR CLAIMS BASED ON THE USE OF THE SOFTWARE IN ANY SUCH ON-LINE EQUIPMENT IN HAZARDOUS ENVIRONMENTS BY YOU. FOR PURPOSES OF THIS PARAGRAPH, THE TERM "LIFE-CRITICAL APPLICATION" MEANS AN APPLICATION IN WHICH THE FUNCTIONING OR MALFUNCTIONING OF THE SOFTWARE MAY RESULT DIRECTLY OR INDIRECTLY IN PHYSICAL INJURY OR LOSS OF HUMAN LIFE. THIS DISCLAIMER OF WARRANTY CONSTITUTES AN ESSENTIAL PART OF THIS LICENSE. NO USE OF ANY COVERED CODE IS AUTHORIZED HEREUNDER EXCEPT UNDER THIS DISCLAIMER.

8 TERMINATION.

8.1.

This License and the rights granted hereunder will terminate automatically if You fail to comply with terms herein and fail to cure such breach within 30 days of becoming aware of the breach. All sublicenses to the Covered Code which are properly granted shall survive any termination of this License. Provisions which, by their nature, must remain in effect beyond the termination of this License shall survive.

8.2.

8.3.

If You assert a patent infringement claim against Participant alleging that such Participant's Contributor Version directly or indirectly infringes any patent where such claim is resolved (such as by license or settlement) prior to the initiation of patent infringement litigation, then the reasonable value of the licenses granted by such Participant under Sections 2.1 or 2.2 shall be taken into account in determining the amount or value of any payment or license.

8.4.

In the event of termination under Sections 8.1 or 8.2 above, all end user license agreements (excluding distributors and resellers) which have been validly granted by You or any distributor hereunder prior to termination shall survive termination.

9 LIMITATION OF LIABILITY.

UNDER NO CIRCUMSTANCES AND UNDER NO LEGAL THEORY, WHETHER TORT (INCLUDING NEGLIGENCE), CONTRACT, OR OTHERWISE, SHALL YOU, THE INITIAL DEVELOPER, ANY OTHER CONTRIBUTOR, OR ANY DISTRIBUTOR OF COVERED CODE, OR ANY SUPPLIER OF ANY OF SUCH PARTIES, BE LIABLE TO ANY PERSON FOR ANY INDIRECT, SPECIAL, INCIDENTAL, OR CONSEQUENTIAL DAMAGES OF ANY CHARACTER INCLUDING, WITHOUT LIMITATION, DAMAGES FOR LOSS OF GOODWILL, WORK STOPPAGE, COMPUTER FAILURE OR MALFUNCTION, OR ANY AND ALL OTHER COMMERCIAL DAMAGES OR LOSSES, EVEN IF SUCH PARTY SHALL HAVE BEEN INFORMED OF THE POSSIBILITY OF SUCH DAMAGES. THIS LIMITATION OF LIABILITY SHALL NOT APPLY TO LIABILITY FOR DEATH OR PERSONAL INJURY RESULTING FROM SUCH PARTY'S NEGLIGENCE TO THE EXTENT APPLICABLE LAW PROHIBITS SUCH LIMITATION. SOME JURISDICTIONS DO NOT ALLOW THE EXCLUSION OR LIMITATION OF INCIDENTAL OR CONSEQUENTIAL DAMAGES, SO THIS EXCLUSION AND LIMITATION MAY NOT APPLY TO YOU.

10 U.S. GOVERNMENT END USERS.

11 MISCELLANEOUS.

12 RESPONSIBILITY FOR CLAIMS.

As between Initial Developer and the Contributors, each party is responsible for claims and damages arising, directly or indirectly, out of its utilization of rights under this License and You agree to work with Initial Developer and Contributors to distribute such responsibility on an equitable basis. Nothing herein is intended or shall be deemed to constitute any admission of liability.

EXHIBIT A.

"The contents of this file are subject to the gSOAP Public License Version 1.3 (the "License"); you may not use this file except in compliance with the License. You may obtain a copy of the License at <http://www.cs.fsu.edu/engelen/soaplicense.html>

Software distributed under the License is distributed on an "AS IS" basis, WITHOUT WARRANTY OF ANY KIND, either express or implied. See the License for the specific language governing rights and limitations under the License.

The Original Code of the gSOAP Software is: stdsoap.h, stdsoap2.h, stdsoap.c, stdsoap2.c, stdsoap.cpp, stdsoap2.cpp, soapcpp2.h, soapcpp2.c, soapcpp2_lex.l, soapcpp2_yacc.y, error2.h, error2.c, symbol2.c, init2.c, soapdoc2.html, and soapdoc2.pdf, httpget.h, httpget.c, stl.h, stldeque.h, stllist.h, stlvector.h, stlset.h.

The Initial Developer of the Original Code is Robert A. van Engelen. Portions created by Robert A. van Engelen are Copyright (C) 2001-2004 Robert A. van Engelen, Genivia inc. All Rights Reserved. Contributor(s):

"-----"
[Note: The text of this Exhibit A may differ slightly from the text of the notices in the Source Code files of the Original code. You should use the text of this Exhibit A rather than the text found in the Original Code Source Code for Your Modifications.] EXHIBIT B.

"Part of the software embedded in this product is gSOAP software. Portions created by gSOAP are Copyright (C) 2001-2009 Robert A. van Engelen, Genivia inc. All Rights Reserved. THE SOFTWARE IN THIS PRODUCT WAS IN PART PROVIDED BY GENIVIA INC AND ANY EXPRESS OR IMPLIED WARRANTIES, INCLUDING, BUT NOT LIMITED TO, THE IMPLIED WARRANTIES OF MERCHANTABILITY AND FITNESS FOR A PARTICULAR PURPOSE ARE DISCLAIMED. IN NO EVENT SHALL THE AUTHOR BE LIABLE FOR ANY DIRECT, INDIRECT, INCIDENTAL, SPECIAL, EXEMPLARY, OR CONSEQUENTIAL DAMAGES (INCLUDING, BUT NOT LIMITED TO, PROCUREMENT OF SUBSTITUTE GOODS OR SERVICES; LOSS OF USE, DATA, OR PROFITS; OR BUSINESS INTERRUPTION) HOWEVER CAUSED AND ON ANY THEORY OF LIABILITY, WHETHER IN CONTRACT, STRICT LIABILITY, OR TORT (INCLUDING NEGLIGENCE OR OTHERWISE) ARISING IN ANY WAY OUT OF THE USE OF THIS SOFTWARE, EVEN IF ADVISED OF THE POSSIBILITY OF SUCH DAMAGE."
<http://www.cs.fsu.edu/~engelen/license.html>

■ About fonts

Fonts are (c) Bitstream (see below). DejaVu changes are in public domain. Glyphs imported from Arev fonts are (c) Tavmjong Bah (see below)

Bitstream Vera Fonts Copyright

Copyright (c) 2003 by Bitstream, Inc. All Rights Reserved. Bitstream Vera is a trademark of Bitstream, Inc.

Permission is hereby granted, free of charge, to any person obtaining a copy of the fonts accompanying this license ("Fonts") and associated documentation files (the "Font Software"), to reproduce and distribute the Font Software, including without limitation the rights to use, copy, merge, publish, distribute, and/or sell copies of the Font Software, and to permit persons to whom the Font Software is furnished to do so, subject to the following conditions:

The above copyright and trademark notices and this permission notice shall be included in all copies of one or more of the Font Software typefaces.

The Font Software may be modified, altered, or added to, and in particular the designs of glyphs or characters in the Fonts may be modified and additional glyphs or characters may be added to the Fonts, only if the fonts are renamed to names not containing either the words "Bitstream" or the word "Vera".

This License becomes null and void to the extent applicable to Fonts or Font Software that has been modified and is distributed under the "Bitstream Vera" names.

The Font Software may be sold as part of a larger software package but no copy of one or more of the Font Software typefaces may be sold by itself.

THE FONT SOFTWARE IS PROVIDED "AS IS", WITHOUT WARRANTY OF ANY KIND, EXPRESS OR IMPLIED, INCLUDING BUT NOT LIMITED TO ANY WARRANTIES OF MERCHANTABILITY, FITNESS FOR A PARTICULAR PURPOSE AND NON-INFRINGEMENT OF COPYRIGHT, PATENT, TRADEMARK, OR OTHER RIGHT. IN NO EVENT SHALL BITSTREAM OR THE GNOME FOUNDATION BE LIABLE FOR ANY CLAIM, DAMAGES OR OTHER LIABILITY, INCLUDING ANY GENERAL, SPECIAL, INDIRECT, INCIDENTAL, OR CONSEQUENTIAL DAMAGES, WHETHER IN AN ACTION OF CONTRACT, TORT OR OTHERWISE, ARISING FROM, OUT OF THE USE OR INABILITY TO USE THE FONT SOFTWARE OR FROM OTHER DEALINGS IN THE FONT SOFTWARE.

Except as contained in this notice, the names of Gnome, the Gnome Foundation, and Bitstream Inc., shall not be used in advertising or otherwise to promote the sale, use or other dealings in this Font Software without prior written authorization from the Gnome Foundation or Bitstream Inc., respectively. For further information, contact: fonts at gnome dot org.

Arev Fonts Copyright

Copyright (c) 2006 by Tavmjong Bah. All Rights Reserved.

Permission is hereby granted, free of charge, to any person obtaining a copy of the fonts accompanying this license ("Fonts") and associated documentation files (the "Font Software"), to reproduce and distribute the modifications to the Bitstream Vera Font Software, including without limitation the rights to use, copy, merge, publish, distribute, and/or sell copies of the Font Software, and to permit persons to whom the Font Software is furnished to do so, subject to the following conditions:

The above copyright and trademark notices and this permission notice shall be included in all copies of one or more of the Font Software typefaces.

The Font Software may be modified, altered, or added to, and in particular the designs of glyphs or characters in the Fonts may be modified and additional glyphs or characters may be added to the Fonts, only if the fonts are renamed to names not containing either the words "Tavmjong Bah" or the word "Arev".

This License becomes null and void to the extent applicable to Fonts or Font Software that has been modified and is distributed under the "Tavmjong Bah Arev" names.

The Font Software may be sold as part of a larger software package but no copy of one or more of the Font Software typefaces may be sold by itself.

THE FONT SOFTWARE IS PROVIDED "AS IS", WITHOUT WARRANTY OF ANY KIND, EXPRESS OR IMPLIED, INCLUDING BUT NOT LIMITED TO ANY WARRANTIES OF MERCHANTABILITY, FITNESS FOR A PARTICULAR PURPOSE AND NON-INFRINGEMENT OF COPYRIGHT, PATENT, TRADEMARK, OR OTHER RIGHT. IN NO EVENT SHALL TAVMJONG BAH BE LIABLE FOR ANY CLAIM, DAMAGES OR OTHER LIABILITY, INCLUDING ANY GENERAL, SPECIAL, INDIRECT, INCIDENTAL, OR CONSEQUENTIAL DAMAGES, WHETHER IN AN ACTION OF CONTRACT, TORT OR OTHERWISE, ARISING FROM, OUT OF THE USE OR INABILITY TO USE THE FONT SOFTWARE OR FROM OTHER DEALINGS IN THE FONT SOFTWARE.

Except as contained in this notice, the name of Tavmjong Bah shall not be used in advertising or otherwise to promote the sale, use or other dealings in this Font Software without prior written authorization from Tavmjong Bah. For further information, contact: tavmjong @ free. fr.

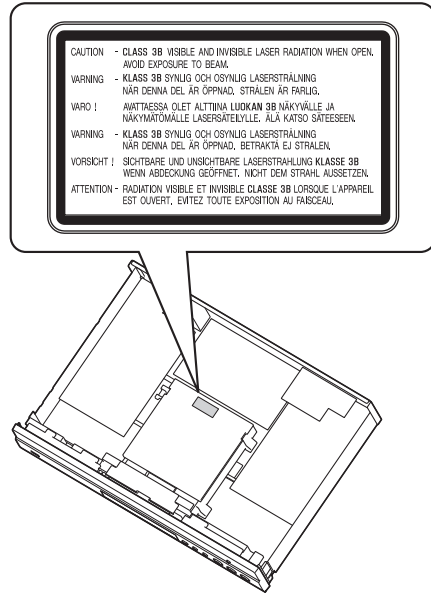
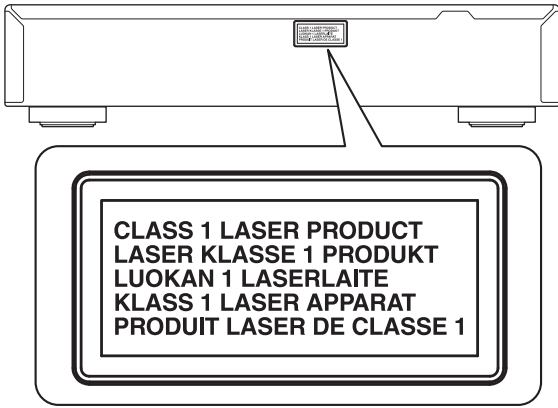

⏻ (전원 키)

본 기기의 전원을 켜거나 대기 모드에 맞추십시오.

