



# *RX-V765*

---

*AV Receiver*

OWNER'S MANUAL

## Caution: Read this before operating your unit.

- 1 To assure the finest performance, please read this manual carefully. Keep it in a safe place for future reference.
- 2 Install this sound system in a well ventilated, cool, dry, clean place – away from direct sunlight, heat sources, vibration, dust, moisture, and/or cold. Allow ventilation space of at least 30 cm on the top, 20 cm on the left and right, and 20 cm on the back of this unit.
- 3 Locate this unit away from other electrical appliances, motors, or transformers to avoid humming sounds.
- 4 Do not expose this unit to sudden temperature changes from cold to hot, and do not locate this unit in an environment with high humidity (i.e. a room with a humidifier) to prevent condensation inside this unit, which may cause an electrical shock, fire, damage to this unit, and/or personal injury.
- 5 Avoid installing this unit where foreign objects may fall onto this unit and/or this unit may be exposed to liquid dripping or splashing. On the top of this unit, do not place:
  - Other components, as they may cause damage and/or discoloration on the surface of this unit.
  - Burning objects (i.e. candles), as they may cause fire, damage to this unit, and/or personal injury.
  - Containers with liquid in them, as they may fall and liquid may cause electrical shock to the user and/or damage to this unit.
- 6 Do not cover this unit with a newspaper, tablecloth, curtain, etc. in order not to obstruct heat radiation. If the temperature inside this unit rises, it may cause fire, damage to this unit, and/or personal injury.
- 7 Do not plug in this unit to a wall outlet until all connections are complete.
- 8 Do not operate this unit upside-down. It may overheat, possibly causing damage.
- 9 Do not use force on switches, knobs and/or cords.
- 10 When disconnecting the power cable from the wall outlet, grasp the plug; do not pull the cable.
- 11 Do not clean this unit with chemical solvents; this might damage the finish. Use a clean, dry cloth.
- 12 Only voltage specified on this unit must be used. Using this unit with a higher voltage than specified is dangerous and may cause fire, damage to this unit, and/or personal injury. Yamaha will not be held responsible for any damage resulting from use of this unit with a voltage other than specified.
- 13 To prevent damage by lightning, keep the power cord and outdoor antennas disconnected from a wall outlet or the unit during a lightning storm.
- 14 Do not attempt to modify or fix this unit. Contact qualified Yamaha service personnel when any service is needed. The cabinet should never be opened for any reasons.
- 15 When not planning to use this unit for long periods of time (i.e. vacation), disconnect the AC power plug from the wall outlet.
- 16 Install this unit near the AC outlet and where the AC power plug can be reached easily.
- 17 Be sure to read the “Troubleshooting” section on common operating errors before concluding that this unit is faulty.
- 18 Before moving this unit, press **Ⓐ MAIN ZONE ON/OFF** to set this unit in the standby mode, and disconnect the AC power plug from the wall outlet.
- 19 **VOLTAGE SELECTOR** (Asia and General models only)  
The **VOLTAGE SELECTOR** on the rear panel of this unit must be set for your local main voltage **BEFORE** plugging into the AC wall outlet. Voltages are:
  - .....AC 110/120/220/230–240 V, 50/60 Hz (General model)
  - ..... AC 220/230–240 V, 50/60 Hz (Asia model)
- 20 The batteries shall not be exposed to excessive heat such as sunshine, fire or like.
- 21 Excessive sound pressure from earphones and headphones can cause hearing loss.
- 22 When replacing the batteries, be sure to use batteries of the same type. Danger of explosion may happen if batteries are incorrectly replaced.

### WARNING

TO REDUCE THE RISK OF FIRE OR ELECTRIC SHOCK, DO NOT EXPOSE THIS UNIT TO RAIN OR MOISTURE.

As long as this unit is connected to the AC wall outlet, it is not disconnected from the AC power source even if you turn off this unit by **Ⓐ MAIN ZONE ON/OFF**. In this state, this unit is designed to consume a very small quantity of power.

# Contents

INTRODUCTION

PREPARATION

BASIC  
OPERATION

ADVANCED  
OPERATION

APPENDIX

English

## INTRODUCTION

<b>Features</b> .....	2
<b>About this manual</b> .....	3
<b>Supplied accessories</b> .....	3
<b>Part names and functions</b> .....	4
Front panel .....	4
Rear panel .....	5
Front panel display.....	6
Remote control.....	7
<b>Quick start guide</b> .....	8

## PREPARATION

<b>Preparing remote control</b> .....	9
Installing batteries in the remote control .....	9
Using the remote control.....	9
<b>Connections</b> .....	10
Placing speakers.....	10
Connecting speakers .....	11
Information on jacks and cable plugs .....	14
Connecting a video monitor.....	15
Connecting other components .....	16
Connecting a multi-format player or an external decoder.....	18
Connecting an external amplifier.....	18
Using REMOTE IN/OUT jacks.....	19
Connecting a Yamaha iPod universal dock or Bluetooth™ wireless audio receiver.....	19
Connecting a camcorder or portable audio player ...	19
Connecting the FM and AM antennas .....	20
Connecting the power cable.....	20
Turning this unit on and off.....	20
<b>Optimizing the speaker setting for your listening room (YPAO)</b> .....	21
Using Auto Setup.....	21
When an error message is displayed during measurement.....	23
When a warning message is displayed after measurement.....	23

## BASIC OPERATION

<b>Playback</b> .....	24
Basic procedure.....	24
Using the SCENE function .....	24
Muting audio output temporarily (MUTE).....	25
Adjusting high/low frequency sound (tone control) .....	25
Enjoying pure hi-fi sound (Pure Direct mode) .....	25
Using your headphones.....	26
Displaying input signal information .....	26
Changing information on the front panel display ...	26
<b>Enjoy the sound field programs</b> .....	27
Selecting sound field programs.....	27
Enjoying unprocessed input sources (Straight decoding mode) .....	30
Enjoying sound field programs without surround speakers (Virtual CINEMA DSP) .....	30
Enjoy sound field programs with headphones (SILENT CINEMA™) .....	30
Enjoying more spatial sound fields (CINEMA DSP 3D mode).....	30
<b>FM/AM tuning</b> .....	31
Tuning into the desired FM/AM station (Frequency tuning mode).....	31
Registering FM/AM stations and tuning in (Preset tuning mode).....	31
<b>Using iPod™</b> .....	33
Controlling iPod™.....	33

<b>Using Bluetooth™ components</b> .....	35
Pairing the Bluetooth™ wireless audio receiver and your Bluetooth™ component.....	35
Playback of the Bluetooth™ component .....	35
<b>Other functions</b> .....	36
Using the sleep timer .....	36
Using the HDMI™ control function.....	36

## ADVANCED OPERATION

<b>Setting the option menu for each input source (OPTION menu)</b> .....	37
OPTION menu items .....	37
Outputting a video signal input from another input source during reproducing a multi-channel audio signal.....	39
<b>Editing surround decoders/sound field programs</b> .....	40
Setting sound field parameters.....	40
Sound field parameters .....	40
<b>Changing various settings of this unit (SETUP menu)</b> .....	44
Basic operation of the SETUP menu .....	45
Speaker Setup .....	45
Sound Setup .....	47
Function Setup .....	48
DSP Parameter.....	50
Memory Guard.....	50
<b>Using multi-zone configuration</b> .....	51
Connecting Zone2.....	51
Controlling Zone2.....	52
<b>Controlling other components with the remote control</b> .....	53
Setting remote control codes.....	53
Resetting all remote control codes.....	54
<b>Advanced setup</b> .....	55

## APPENDIX

<b>Troubleshooting</b> .....	57
General.....	57
HDMI™.....	60
Tuner (FM/AM).....	61
Remote control.....	61
iPod™.....	62
Bluetooth™.....	63
Auto Setup (YPAO).....	63
<b>Glossary</b> .....	66
<b>Sound field program information</b> .....	68
<b>Information on HDMI™</b> .....	69
<b>Specifications</b> .....	70
<b>Index</b> .....	71

(at the end of this manual)

List of remote control codes.....	i
-----------------------------------	---

# INTRODUCTION

## Features

### ■ Built-in 7-channel power amplifier

- Minimum RMS Output Power (20 Hz-20 kHz, 0.08% THD, 8 Ω)
- FRONT L/R: 95 W + 95 W
- CENTER: 95 W
- SURROUND L/R: 95 W + 95 W
- SURROUND BACK L/R: 95 W + 95 W

### ■ Speaker/Preout outputs

- Speaker jacks (7-channel + presence 2-channel), preout output jacks (7-channel, and subwoofer preout jack x 2)

### ■ Input/Output terminals

#### Input terminals

- HDMI input x 4
- Audio/Video input
  - [Audio] Digital input (coaxial) x 2, digital input (optical) x 2, analog input x 2
  - [Video] Component video x 2, composite video x 4
- Audio input (analog) x 2
- Phono input x 1
- Multi-channel audio input x 1
- Dock input x 1
- V-AUX input
  - [Audio] Analog x 1, stereo mini jack x 1
  - [Video] Composite video x 1

#### Output terminals

- Monitor output
  - [Audio/Video] HDMI x 1
  - [Video] Component video x 1, Composite video x 1
- Audio/Video output
  - [Audio] Analog x 1
  - [Video] Composite video x 1
- Audio output
  - Analog x 1
- Zone2 output
  - Analog x 1

#### Other terminals

- Remote input x 1, Remote output x 1
- Trigger output x 1

### ■ Proprietary Yamaha technology for the creation of sound fields

- CINEMA DSP 3D
- Compressed Music Enhancer mode
- Virtual CINEMA DSP
- SILENT CINEMA™

### ■ Digital audio decoders

- Dolby TrueHD, Dolby Digital Plus
- DTS-HD Master Audio, DTS-HD High Resolution Audio, DTS Express
- Dolby Digital, Dolby Digital EX
- DTS, DTS 96/24, DTS-ES Matrix 6.1, DTS-ES Discrete 6.1

- Dolby Pro Logic, Dolby Pro Logic II, Dolby Pro Logic Ix
- DTS NEO:6
- DSD

### ■ Sophisticated FM/AM tuner

- 40-station random and direct preset tuning
- Automatic preset tuning

### ■ HDMI™ (High-Definition Multimedia Interface)

- HDMI interface for standard, enhanced or high-definition video as well as multi-channel digital audio
  - Automatic audio and video synchronization (lip sync) information capability
  - Deep Color video signal (30/36 bit) transmission capability
  - “x.v.Color” video signal transmission capability
  - High refresh rate and high resolution video signals capability
  - High definition digital audio format signals capability
- Analog video to HDMI digital video up-conversion (composite video → HDMI, component video → HDMI) capability for monitor out
- Analog video input up-scaling for HDMI digital video output 576i or 576p → 720p, 1080i or 1080p
- HDMI control capability

### ■ DOCK jack

- DOCK jack to connect a Yamaha iPod universal dock (such as YDS-11, sold separately) or Bluetooth wireless audio receiver (such as YBA-10, sold separately)



### ■ Automatic speaker setup features

- “YPAO” (Yamaha Parametric Room Acoustic Optimizer) for automatically optimizing speaker outputs suitable for listening environments

### ■ Other features

- 192-kHz/24-bit D/A converter
- OSD (on-screen display) menus that allow you to optimize this unit to suit your individual audiovisual system
- Pure Direct mode for pure hi-fi sound for all sources
- Adaptive dynamic range controlling capability
- SCENE function that allows you to change input sources and sound field programs with one key
- Sleep timer
- Multi-zone function

# About this manual

- Some operations can be performed by using either the keys on the front panel or the ones on the remote control. In case the key names differ between the front panel and the remote control, the key name on the remote control is given in parentheses.
- This manual is printed prior to production. Design and specifications are subject to change in part as a result of improvements, etc. In case of differences between the manual and product, the product has priority.
- “**A** **MAIN ZONE ON/OFF**” or “**5** **HDMI 1**” (example) indicates the name of the parts on the front panel or the remote control. Refer to the “Controls diagram” or “Part names and functions” on page 4 for the information about each position of the parts.
-  indicates a tip for your operation.
-  indicates the page describing the related information.



Manufactured under license from Dolby Laboratories.  
Dolby, Pro Logic and the double-D symbol are trademarks of Dolby Laboratories.



Manufactured under license under U.S. Patent No's:  
5,451,942;5,956,674;5,974,380;5,978,762;6,226,616;6,487,535 &  
other U.S. and worldwide patents issued & pending. DTS is a  
registered trademark and the DTS logos, Symbol, DTS-HD and DTS-  
HD Master Audio are trademark of DTS, Inc. © 1996-2007 DTS, Inc.  
All Rights Reserved.

### iPod™

“iPod” is a trademark of Apple Inc., registered in the U.S. and other countries.

### Bluetooth™

Bluetooth is a registered trademark of Bluetooth SIG and is used by Yamaha in accordance with a license agreement.



“HDMI,” the “HDMI” logo and “High-Definition Multimedia Interface” are trademarks, or registered trademarks of HDMI Licensing LLC.

### x.v.Color™

“x.v.Color” is a trademark of Sony Corporation.



“SILENT CINEMA” is a trademark of Yamaha Corporation.

# Supplied accessories

Check that you received all of the following parts.

- Remote control (see page 9)
- Batteries (AAA, R03, UM-4) x 2 (see page 9)
- Optimizer microphone (see page 21)
- AM loop antenna (see page 20)
- Indoor FM antenna (see page 20)
- Controls diagram

# Part names and functions

## Front panel

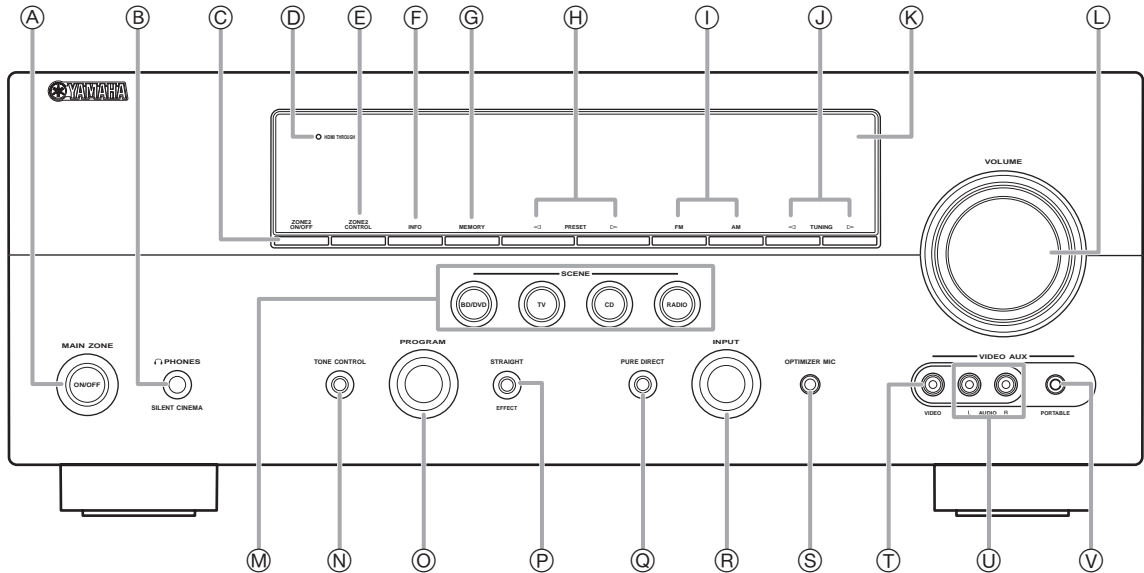

- A MAIN ZONE ON/OFF**  
Turns this unit on and off (see page 20).
- B PHONES jack**  
For connecting headphones (see page 26).
- C ZONE2 ON/OFF**  
Switches Zone2 between on and off (see page 52).
- D HDMI THROUGH**  
During standby, lights up under the following conditions:
- the HDMI control function is enabled (see page 48).
  - an HDMI signal input to this unit passes through this unit and output (see page 48).
- E ZONE2 CONTROL**  
Enables operation of a receiver set in Zone2, including input source switching, volume control and tuner operation, with the main amplifier or remote control after this key is pressed.
- F INFO**  
Changes information on the front panel display, such as input source and sound field program name (see page 26).
- G MEMORY**  
Registers FM/AM stations as preset stations (see page 32).
- H PRESET </>**  
Selects an FM/AM preset station (see page 32).
- I FM/AM**  
Changes the tuner bands between FM and AM.
- J TUNING </>**  
Changes FM/AM frequencies.
- K Front panel display**  
Displays information on this unit (see page 6).
- L VOLUME control**  
Controls the volume of this unit (see page 24).
- M SCENE**  
Switches between linked sets of input sources and sound field programs (see page 24).
- N TONE CONTROL**  
Adjusts high-frequency/low-frequency output of speakers/headphones (see page 24).
- O PROGRAM selector**  
Changes sound field programs (see page 27).
- P STRAIGHT**  
Toggles between the selected sound field program and straight decoding mode (see page 30).
- Q PURE DIRECT**  
Changes mode to Pure Direct mode (see page 25). This key lights up when Pure Direct mode is on.
- R INPUT selector**  
Selects an input source (see page 24).
- S OPTIMIZER MIC jack**  
For connecting the supplied optimizer microphone and adjusting output characteristics of speakers (see page 21).
- T VIDEO (VIDEO AUX) jack**  
For connecting the video output cable of a camcorder or game console (see page 19).
- U AUDIO L/R (VIDEO AUX) jack**  
For connecting the audio output cable of a camcorder or game console (see page 19).
- V PORTABLE (VIDEO AUX) jack**  
For connecting the audio output cable of a portable music player (see page 19).

## Rear panel

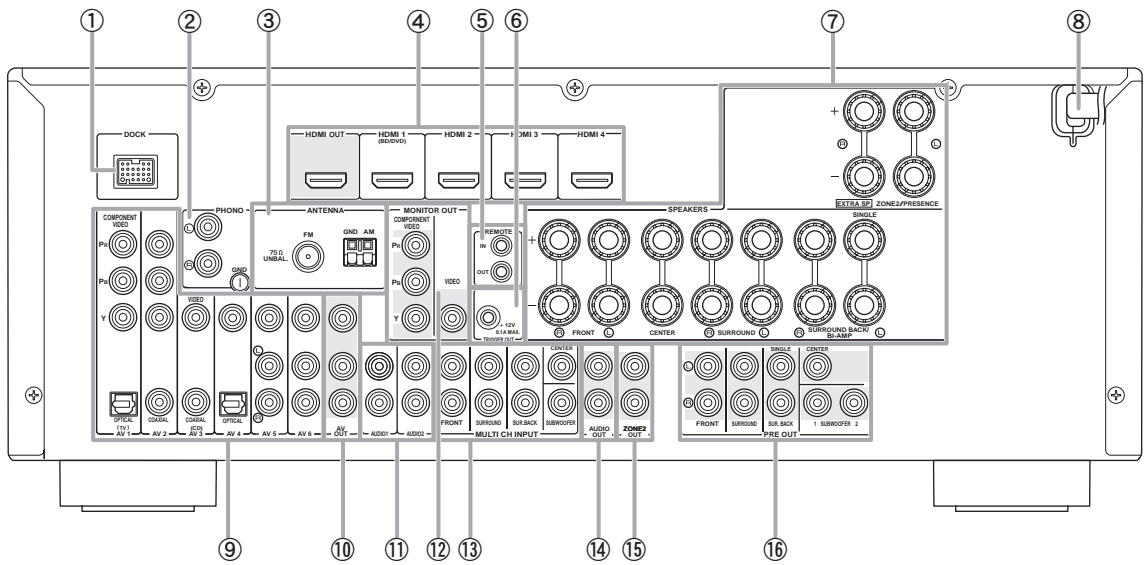

- ① **DOCK jack**  
For connecting a Yamaha iPod universal dock (YDS-11, sold separately) or a Bluetooth wireless audio receiver (YBA-10, sold separately) (see page 19).
- ② **PHONO jacks**  
For connecting a turntable (see page 17).
- ③ **ANTENNA jacks**  
For connecting supplied FM and AM antennas (see page 20).
- ④ **HDMI OUT/HDMI 1-4 jacks**  
For connecting an HDMI-compatible video monitor or external components for HDMI inputs 1-4 (see page 16).
- ⑤ **REMOTE IN/OUT jacks**  
For connecting an external component that supports the remote control function (see page 19).
- ⑥ **TRIGGER OUT jack**  
For connecting an external terminal with a trigger input terminal to operate it linked with operation of this unit. For example, when an electric screen that supports a trigger input is connected, it opens and closes linked with operation of an input source selected in this unit.
- ⑦ **SPEAKERS terminals**  
For connecting front right and left, center, surround and surround back speakers (see page 11). Connect the presence speakers (see page 12) or the speakers for Zone2 (see page 51) to the EXTRA SP jacks.
- ⑧ **Power Cable**  
Connect this cable to an AC wall outlet (see page 20).
- ⑨ **AV 1-6 jacks**  
For connecting external components for audio/video inputs 1-6 (see page 16).
- ⑩ **AV OUT jacks**  
Outputs audio/video signals from a selected analog input source to an external component (see page 17).
- ⑪ **AUDIO 1/2 jacks**  
For connecting external components for audio inputs 1-2 (see page 17).
- ⑫ **MONITOR OUT terminals**  
Outputs video signals from this unit to a video monitor, such as a TV (see page 15).
- ⑬ **MULTI CH INPUT terminals**  
For connecting a player that supports a multi-channel output (see page 18).
- ⑭ **AUDIO OUT jacks**  
Outputs audio signals from a selected analog input source to an external component (see page 17).
- ⑮ **ZONE2 OUT jacks**  
Outputs sound of this unit to an external amplifier set in a different zone.
- ⑯ **PRE OUT terminals**  
For connecting a subwoofer with built-in amplifier (see page 11) or an external power amplifier (see page 18).

## Front panel display

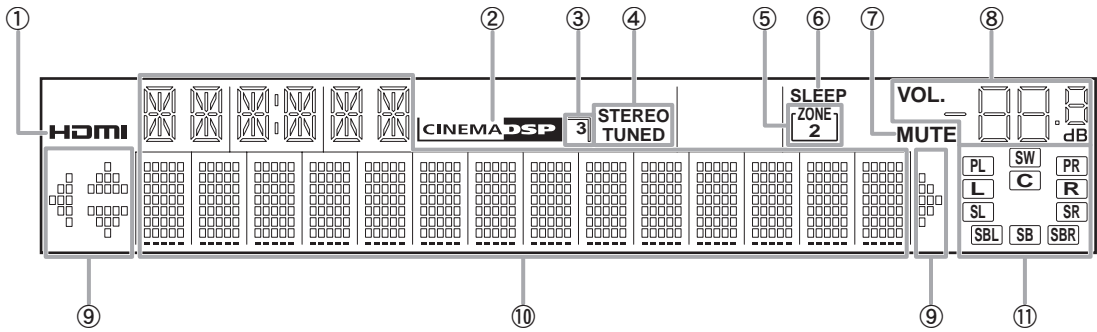

- ① **HDMI indicator**  
Lights up during normal communication when HDMI is selected as an input source.
- ② **CINEMA DSP indicator**  
Lights up when a sound field program that uses CINEMA DSP is selected.
- ③ **CINEMA DSP 3D indicator**  
Lights up when CINEMA DSP 3D is activated.
- ④ **Tuner indicator**  
Lights up during receiving radio broadcast signals from an FM/AM station (see page 31).
- ⑤ **ZONE2 indicator**  
Lights up when Zone2 is turned on (see page 51).
- ⑥ **SLEEP indicator**  
Lights up when the sleep timer is activated (see page 36).
- ⑦ **MUTE indicator**  
Flashes when audio is muted.
- ⑧ **VOLUME indicator**  
Displays volume levels.
- ⑨ **Cursor indicators**  
Light up when corresponding cursors on the remote control are available for operations.
- ⑩ **Multi information display**  
Displays menu items and settings for the current operation.
- ⑪ **Speaker indicators**  
Indicate speaker terminals from which signals are currently output.

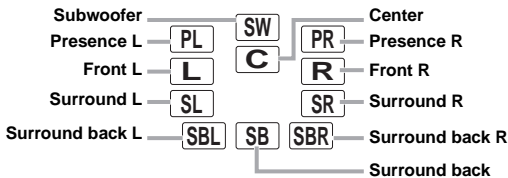



## Remote control

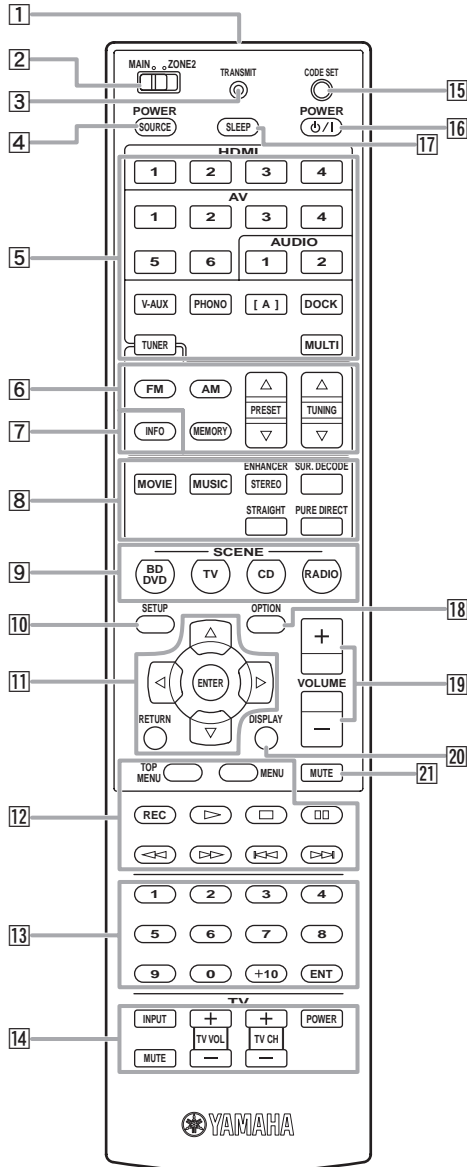

- 1 Remote control signal transmitter**  
Transmits infrared signals.
- 2 MAIN/ZONE2**  
Switches the zone to be operated by the remote control between the Main zone and Zone2 (see page 52).
- 3 TRANSMIT**  
Lights up when a signal is output from the remote control.
- 4 SOURCE POWER**  
Switches an external component on and off.
- 5 Input selection keys**  
**HDMI 1-4** Select HDMI inputs 1 through 4.  
**AV 1-6** Select AV inputs 1 through 6.  
**AUDIO 1/2** Select AUDIO inputs 1 and 2.  
**V-AUX** Selects the V-AUX jack on the front panel of this unit.

- PHONO** Selects a component such as a turntable that is connected to the PHONO jack on the rear panel as an input source.
- [A]** To control external components using the **12 External component operation keys** separately from operations of this unit (see page 53).
- DOCK** Selects a Yamaha iPod universal dock/Bluetooth wireless audio receiver connected to the DOCK jack.
- TUNER MULTI** Selects the FM/AM tuner.  
Selects a signal input from the MULTI CH INPUT jack on the rear panel as an input source.
- 6 Tuner keys**  
**FM** Select the FM band or AM band.  
**AM**  
**MEMORY** Presets radio stations.  
**PRESET  $\Delta / \nabla$**  Select a preset station.  
**TUNING  $\Delta / \nabla$**  Change tuning frequencies.
- 7 INFO**  
Changes information on the front panel display, such as input source and sound field program name (see page 26).
- 8 Sound selection keys**  
Selects sound field programs (see page 27).
- 9 SCENE**  
Switch between linked sets of input sources and sound field programs (see page 24).
- 10 SETUP**  
Displays the SETUP menu (see page 45).
- 11 Cursors  $\Delta / \nabla / \leftarrow / \rightarrow$  / ENTER/RETURN**  
**Cursors  $\Delta / \nabla / \leftarrow / \rightarrow$**  Select menu items displayed on the front panel display or on a video monitor, or change settings.  
**ENTER** Confirms a selected item.  
**RETURN** Returns to the previous screen or ends the menu display.
- 12 External component operation keys**  
Operate recording, playback etc. of external components (see page 53).
- 13 Numeric keys**  
Enter numbers.
- 14 TV control keys**  
Enable operations of a monitor such as a TV and a projector.
- 15 CODE SET**  
Sets remote control codes for external component operations (see page 53).
- 16 POWER**  
Switches this unit on and standby.
- 17 SLEEP**  
Switches the sleep timer operations (see page 36).
- 18 OPTION**  
Displays the OPTION menu (see page 37).
- 19 VOLUME +/-**  
Adjust the volume of this unit (see page 24).
- 20 DISPLAY**  
Changes the operation mode of the iPod connected to the Yamaha iPod universal dock (see page 33).
- 21 MUTE**  
Turns the mute function of the sound output on and off (see page 25).

# Quick start guide

When you use this product for the first time, perform the steps below. See the related pages for details of operations and settings.

## Step 1: Prepare items for setup

Prepare speakers, DVD player, cables, and other items necessary for setup.

For example, prepare the following items for setting up a 7.1-channel sound system.

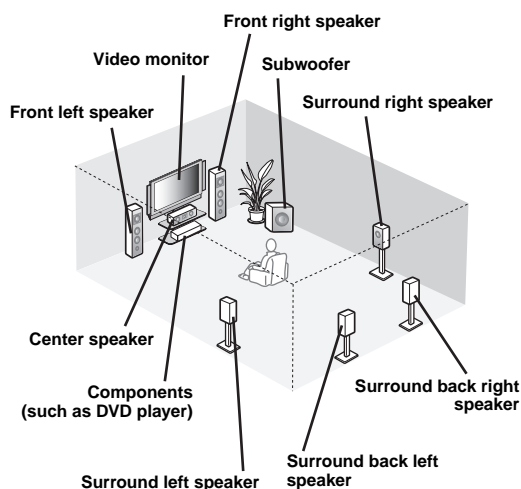

Requirements		qty.
Speakers	Front speaker	2
	Center speaker	1
	Surround speaker	2
	Surround back speaker	2
Active subwoofer		1
Speaker cable		5
Subwoofer cable		1
Reproduction component such as DVD player		1
Video monitor such as TV		1
Video cable or HDMI cable		2
Audio cable		2



- Prepare at least two (front) speakers. Speakers other than front speakers may be used in the following order of preference:
  - 1 Two surround speakers
  - 2 One center speaker
  - 3 One or two surround back speakers
- If your video monitor is a CRT, we recommend that you use magnetically shielded speakers.
- An audio cable is not required when you use an HDMI cable.

## Step 2: Set up your speakers

Place your speakers in the room and connect them to this unit.

- Placing speakers P. 10
- Connecting speakers P. 11



- This unit has a YPAO (Yamaha Parametric Room Acoustic Optimizer) that automatically optimizes this unit based on room acoustic characteristics (audio characteristics of the speakers, speaker positions, and room acoustics, etc.). You can enjoy good balanced sound without special knowledge by using the YPAO technology (see page 21).

## Step 3: Connect your components

Connect your TV, DVD player, or other components.

- Connecting a video monitor P. 15
- Connecting other components P. 16
- Connecting a multi-format player or an external decoder P. 18
- Connecting an external amplifier P. 18
- Connecting a Yamaha iPod universal dock or Bluetooth wireless audio receiver P. 19
- Connecting the FM and AM antennas P. 20

## Step 4: Turn on the power

Connect the power cable and turn on this unit.

- Connecting the power cable P. 20
- Turning this unit on and off P. 20

## Step 5: Select the input source and start playback

Select the component connected in the step 3 as an input source and start playback.

- Basic procedure P. 24
- Selecting sound field programs P. 27



- This unit supports the SCENE function that changes the input source and sound field program at one time. Four SCENE are preset for different purposes for Blu-ray disc, DVD and CD. You can select a SCENE from those just by pressing a remote control key. See page 24 for details.

# PREPARATION

## Preparing remote control

### Installing batteries in the remote control

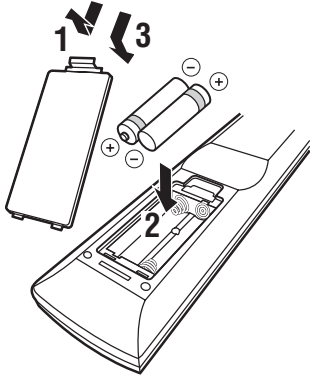

- 1** Take off the battery compartment cover.
- 2** Insert the two supplied batteries (AAA, R03, UM-4) according to the polarity markings (+ and -) on the inside of the battery compartment.
- 3** Snap the battery compartment cover back into place.

#### Notes

- Change all batteries if you notice the following conditions:
  - the operation range of the remote control narrows.
  - the transmit indicator does not flash or is dim.
- Do not use old batteries together with new ones.  
This may shorten the life of the new batteries or cause old batteries to leak.
- Do not use different types of batteries (such as alkaline and manganese batteries) together. Specification of batteries may be different even though they look the same.
- If you find leaking batteries, discard the batteries immediately, taking care not to touch the leaked material. If the leaked material comes into contact with your skin or gets into your eyes or mouth, rinse it away immediately and consult a doctor. Clean the battery compartment thoroughly before installing new batteries.
- Dispose of the old batteries correctly in accordance with your local regulations.
- If the remote control is without batteries for more than 2 minutes, or if exhausted batteries remain in the remote control, the contents of the memory may be cleared. In such a case, install new batteries and set the remote control code.

### Using the remote control

The remote control transmits a directional infrared ray. Be sure to aim the remote control directly at the remote control sensor on this unit during operation.

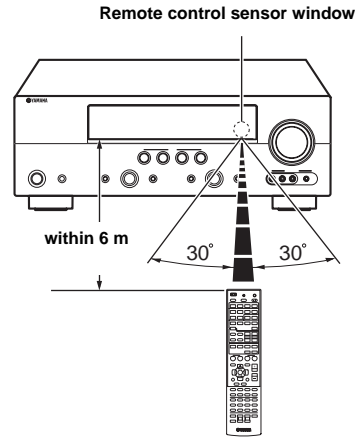

#### Notes

- Do not spill water or other liquids on the remote control.
- Do not drop the remote control.
- Do not leave or store the remote control in the following conditions:
  - places of high humidity, such as near a bath
  - places of high temperatures, such as near a heater or stove
  - places of extremely low temperatures
  - dusty places
- ☀️ You can operate external components with this remote control by setting the remote control code. See page 53 for details.

## Placing speakers

This unit supports up to 7.1-channel surround playback. We recommend the following speaker layout in order to obtain the optimum surround effect.

### 7.1-channel speaker layout

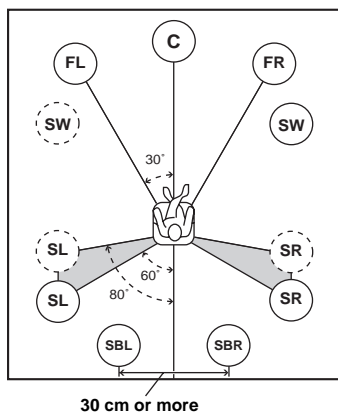

### 6.1-channel speaker layout

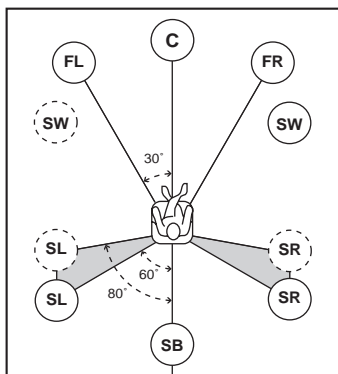

### 5.1-channel speaker layout

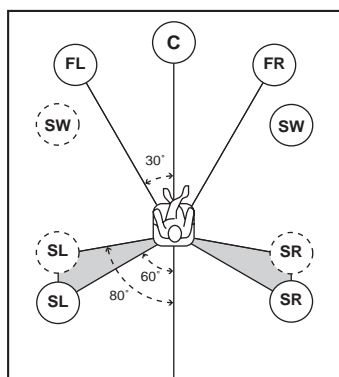

### Speaker channels

#### ■ Front left and right speakers (FL and FR)

The front speakers output the front channel sounds (stereo sound) and effect sounds. Place these speakers at an equal distance from the ideal listening position. When using a screen, the appropriate top positions of the speakers are about 1/4 of the screen from the bottom.

#### ■ Center speaker (C)

The center speaker outputs the center channel sounds (dialog, vocals, etc.). Place it halfway between the left and right speakers. When using a TV, place the speaker just above or just under the center of the TV with the front surfaces of the TV and the speaker aligned. When using a screen, place it just under the center of the screen.

#### ■ Surround left and right speakers (SL and SR)

The surround speakers output effect sounds and surround sounds. Place them at the rear left and rear right facing the listening position.

To obtain a natural sound flow in the 5.1-channel speaker layout, place them slightly further back than in the 7.1-channel speaker layout.

#### ■ Surround back left and right speakers (SBL and SBR) / Surround back speaker (SB)

The surround back left and right speakers output rear effect sounds. Place them at the rear of the room facing the listening position at least 30 cm away from each other, ideally at the same distance as that between the front left and right speakers.

In the 6.1-channel speaker layout, surround back left and right channel sound signals are mixed down and output from the single surround back speaker.

In the 5.1-channel speaker layout, surround back left and right channel sound signals are output from the surround left and right speakers.

#### ■ Subwoofer (SW)

The subwoofer speaker outputs bass sounds and low-frequency effect (LFE) sounds included in Dolby Digital and DTS signals. Use a subwoofer with a built-in amplifier, such as the Yamaha Active Servo Processing Subwoofer System. Place it exterior to the front left and right speakers facing slightly inward to reduce reflections from a wall.

## Connecting speakers

When you connect speakers, connect them to the respective jacks as follows, according to your speaker layout.



- You can connect up to two subwoofers. When two subwoofers are connected, the same sound is output from them.

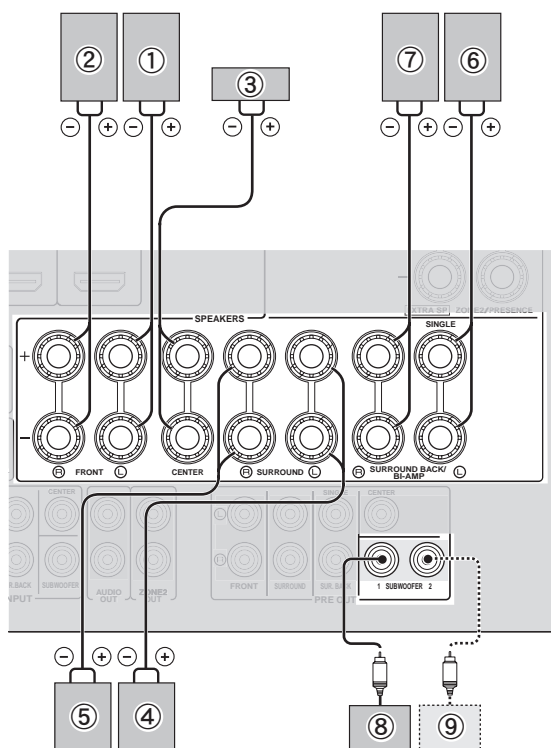

### 7.1-channel

Speakers	Jacks on this unit
① Front speaker L	FRONT (L)
② Front speaker R	FRONT (R)
③ Center speaker	CENTER
④ Surround speaker L	SURROUND (L)
⑤ Surround speaker R	SURROUND (R)
⑥ Surround back speaker L	SURROUND BACK/BI-AMP (L)
⑦ Surround back speaker R	SURROUND BACK/BI-AMP (R)
⑧ Subwoofer 1	SUBWOOFER 1
⑨ Subwoofer 2 (optional)	SUBWOOFER 2

### 6.1-channel

Speakers	Jacks on this unit
① Front speaker L	FRONT (L)
② Front speaker R	FRONT (R)
③ Center speaker	CENTER
④ Surround speaker L	SURROUND (L)
⑤ Surround speaker R	SURROUND (R)
⑥ Surround back speaker	SURROUND BACK/BI-AMP (SINGLE)
⑧ Subwoofer 1	SUBWOOFER 1
⑨ Subwoofer 2 (optional)	SUBWOOFER 2

### 5.1-channel

Speakers	Jacks on this unit
① Front speaker L	FRONT (L)
② Front speaker R	FRONT (R)
③ Center speaker	CENTER
④ Surround speaker L	SURROUND (L)
⑤ Surround speaker R	SURROUND (R)
⑧ Subwoofer 1	SUBWOOFER 1
⑨ Subwoofer 2 (optional)	SUBWOOFER 2

## Presence speakers

You can connect presence speakers (PL/PR) that output front effect sounds to this unit. With CINEMA DSP sound field programs (see page 27) and their CINEMA DSP 3D functions, a sound with a richer and more spacial presence can be created. You can adjust the vertical position of center sound such as a dialog (see page 45).

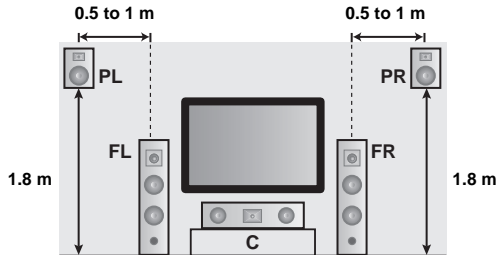

To use the presence speakers, connect them to the EXTRA SP jacks and set “Extra SP Assign” in “Speaker Setup” in the SETUP menu to “Presence” (see page 45).

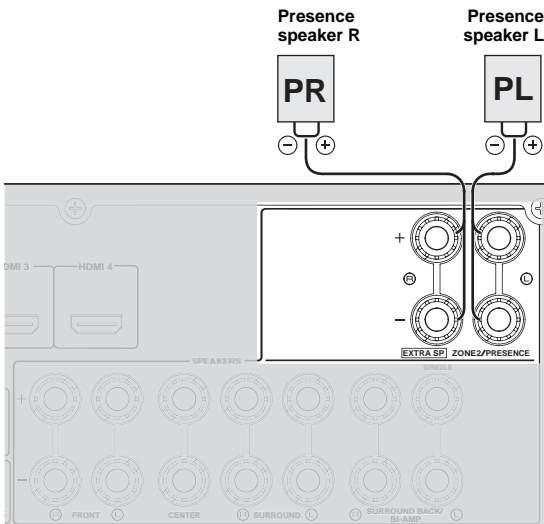

- Although you can connect both surround back speakers and presence speakers to this unit, you cannot output sounds from those speakers at the same time. This unit automatically selects speakers to output sounds according to the selected input source and sound field program.
- You can connect Zone2 speakers with a multi-zone function to the EXTRA SP jacks. For details, see page 51.

## Connecting the speaker cable

### Caution

- A speaker cable is a pair of insulated cables running side by side in general. One of the cables is colored differently or striped to indicate a polarity. Connect one end of the colored/striped cable to the “+” (red) terminal of this unit and the other end to that of your speaker, and connect one end of the other cable to the “-” (black) terminal of this unit and the other end to that of your speaker.
- Before connecting the speakers, be sure to disconnect the power cable.
- Do not let the bare speaker wires touch each other or any metal part of this unit. This could damage this unit and/or speakers. If the circuit shorts out, “CHECK SP WIRES!” appears on the front panel display when this unit is turned on.
- If your video monitor is a CRT, use magnetically shielded speakers. If images on the monitor are still distorted even when you use the magnetically shielded speakers, place the speakers away from the monitor.
- Use speakers with an impedance of 6-ohm or larger. Set speaker impedance in “ADVANCED SETUP” before connecting the speakers. You can also use 4-ohm speakers as the front speakers when you set “SP IMP” to “6ΩMIN” (see page 55).

- 1 Remove approximately 10 mm of insulation from the end of each speaker cable and then twist bare wires of the cable together so that they will not cause a short circuits.

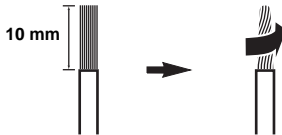

- 2 Loosen the knob, insert the twisted bare wires into the hole, and then tighten the knob.

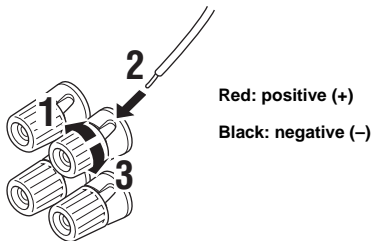

- You can connect the presence speakers (see page 12) or the speakers in the second zone (Zone2) (see page 51) to the EXTRA SP jacks.

### Connecting the banana plug (Except U.K., Europe, Russian, Asia and Korea models)

Tighten the knob, and then insert the banana plug into the end of the terminal.

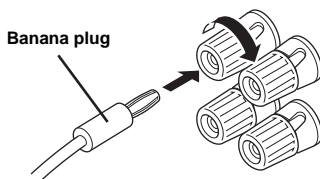

### Using bi-amplification connections

You can connect speakers that support bi-amplification connections to this unit. To connect the speakers via a bi-amp connection, connect them to the FRONT jacks and SURROUND BACK/BI-AMP jacks as illustrated.

To enable the bi-amp connection, connect the power cable to the wall outlet, display the ADVANCED SETUP menu and set “BI AMP” to “ON” (see page 55).

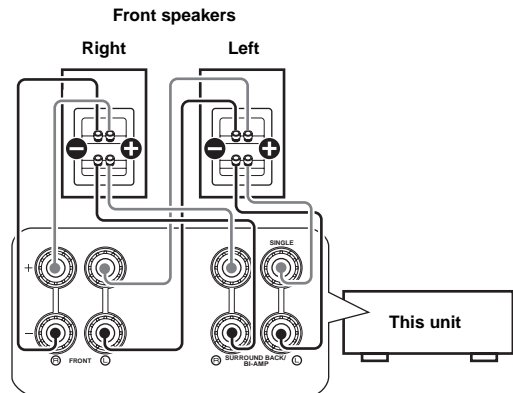

### Caution

Before making bi-amplification connections, remove any brackets or cables that connect a woofer with a tweeter. Refer to the instruction manuals of speakers for details.

When not making bi-amplification connections, make sure that the brackets or cables are connected before connecting the speaker cables.

### Note

- You cannot use surround back speakers or extra speakers (presence and Zone2 speakers) when bi-amplification connections are made.

## Information on jacks and cable plugs

This unit has the following input and output jacks. Use jacks and cables appropriate for components that you are connecting.

### ■ Audio jacks

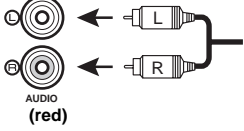
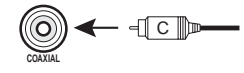
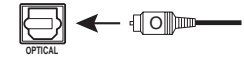
Jack and cables	Description
<b>AUDIO jacks</b> (white)  AUDIO (red)	To transmit conventional analog (stereo) signals. Use stereo pin cables. Connect red plugs to red jacks (R) and white plugs to white jacks (L).
<b>COAXIAL jacks</b> (orange)  COAXIAL	To transmit coaxial digital audio signals. Use pin cables for digital audio signals.
<b>OPTICAL jacks</b>  OPTICAL	To transmit optical digital audio signals. Use optical fiber cables for optical digital audio signals.

### ■ Video jacks

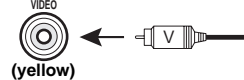
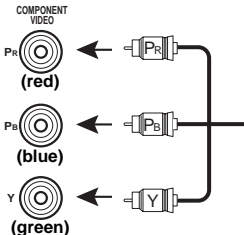
Jack and cables	Description
<b>VIDEO jacks</b>  VIDEO (yellow)	To transmit conventional composite video signals. Use video pin cables.
<b>COMPONENT VIDEO jacks</b>  COMPONENT VIDEO (red) COMPONENT VIDEO (blue) COMPONENT VIDEO (green)	To transmit component video signals that include luminance (Y), chrominance blue (Pb) and chrominance red (Pr) components. Use component video cables.

### ■ Video/audio jacks

Jack and cables	Description
<b>HDMI jacks</b> 	To transmit digital video and digital audio signals. Use HDMI cables.



- We recommend that you use a commercially available 19-pin HDMI cable no longer than 5 meters (16 feet) with the HDMI logo printed on it.
- If you connect this unit to a component that has a DVI jack, an HDMI/DVI-D cable is required.
- You can check error information on HDMI connections (see page 69).

A video signal input to this unit is output from the jacks in MONITOR OUT for the same kind of signal as the input signal.

For example, if a VCR with a composite output signal and a DVD player with a component video output signal are connected, connect both VIDEO jack and COMPONENT VIDEO jack in MONITOR OUT to the video monitor.

If an HDMI input compatible monitor is connected, this unit automatically converts an analog signal that is input from a video input jack to a digital video signal, and then outputs it from the HDMI OUT jack.

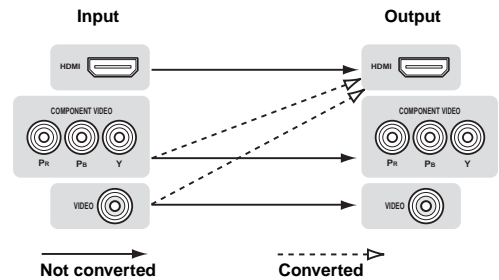



## Connecting a video monitor

Connect a video monitor such as a TV or projector to an output jack of this unit. You can select one of the following three types according to the input signal format supported by the video monitor: HDMI OUT, COMPONENT VIDEO and VIDEO (composite video).

### Note

- Make sure that this unit and video monitor are unplugged from the AC wall outlets.

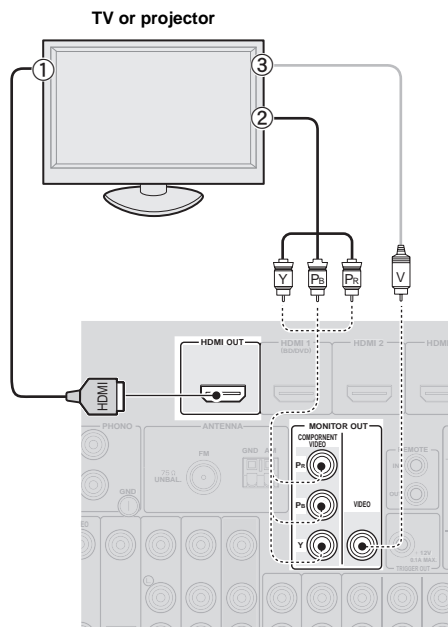

### To connect an HDMI video monitor

Jacks on components	Jacks on this unit
① HDMI input	HDMI OUT



- This unit supports the HDMI control function. By connecting a TV that supports the HDMI control, operations of this unit can be controlled with the remote control of the TV. For details, see page 36.

### To connect component video monitor

### Note

- Only video signals input from this unit via the COMPONENT VIDEO jack are output from the COMPONENT VIDEO jack.

Jacks on components	Jacks on this unit
② Component video output	MONITOR OUT (COMPONENT VIDEO)

### To connect composite video monitor

### Note

- Only video signals input from this unit via the VIDEO jacks are output from the VIDEO jacks.

Jacks on components	Jacks on this unit
③ Video input (composite)	MONITOR OUT (VIDEO)

## Outputting sound of a TV from this unit

To output sound of a TV from this unit, connect an audio output terminal of the TV to any of the AV 1-6 jacks. If the TV supports an optical digital output, we recommend that you use the AV 1. Connecting to the AV 1 allows you to switch an input source to the AV input 1 with a just a single key operation using the SCENE function (see page 24).

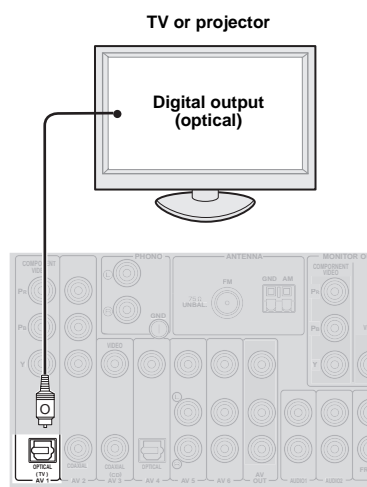

### Note

- If the video monitor connected to this unit supports the HDMI control function, we recommend that you connect its audio output jack to the OPTICAL jack of the AV1 jacks of this unit. By doing so, this unit automatically turns on and "TV" of SCENE is automatically selected when you turn on the video monitor. You can obtain the same result even if you connect the audio output jacks to the AV2-6, AUDIO1-2 or V-AUX jacks by assigning those jacks to TV in advance (see page 24).

## Connecting other components

This unit has input and output jacks for respective input and output sources. You can reproduce sound and movies from input sources selected with the front panel display or remote control.

### Note

- Make sure that this unit and other components are unplugged from the AC wall outlets.

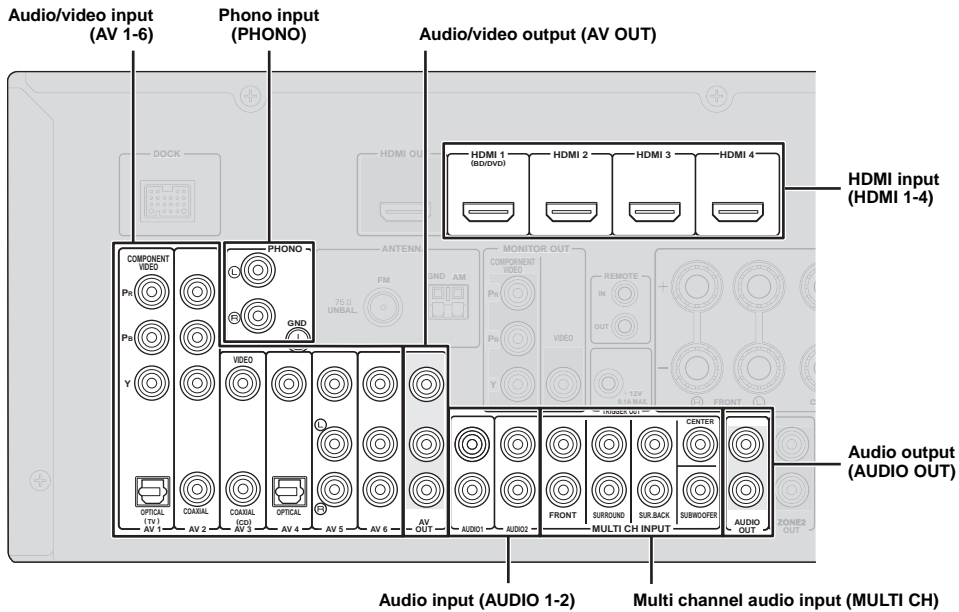

### ■ Audio and video player/Set-top box

Output jacks on the connected external component			Input sources/jacks of this unit	
External components	Signals	Output jacks		
External component with HDMI output	Audio/Video	HDMI output	HDMI1 (BD/DVD)	HDMI 1
			HDMI2	HDMI 2
			HDMI3	HDMI 3
			HDMI4	HDMI 4
External component with component video output	Audio	Optical digital output	AV1 (TV)	OPTICAL
		Component video output		COMPONENT VIDEO
	Video	Coaxial digital output	AV2	COAXIAL
		Component video output		COMPONENT VIDEO
External component with composite video output	Audio	Coaxial digital output	AV3 (CD)	COAXIAL
		Composite video output		VIDEO
	Video	Optical digital output	AV4	OPTICAL
		Composite video output		VIDEO
	Audio	Analog audio output	AV5	AUDIO
		Composite video output		VIDEO
	Video	Analog audio output	AV6	AUDIO
		Composite video output		VIDEO



- Input sources in parentheses are recommended to connect to the respective jacks. If a component is compatible with the SCENE function, you can switch the input source to that component with a single key operation using the SCENE function (see page 24).
- You can change the name of the input source displayed on the front panel display or the video monitor as necessary (see page 50).
- See page 51 on how to use ZONE2 OUT jack.

## ■ Audio player

Output jacks on the connected external component		Input sources/jacks of this unit	
External components	Output jacks		
External component with optical digital output	Optical digital output	AV 1 (TV)	OPTICAL
		AV 4	OPTICAL
External component with coaxial digital output	Coaxial digital output	AV 2	COAXIAL
		AV 3 (CD)	COAXIAL
External component with analog audio output	Analog audio output	AV 5	AUDIO
		AV 6	AUDIO
		AUDIO 1	AUDIO
		AUDIO 2	AUDIO
Turntable	Analog audio output	PHONO	PHONO



- When connecting a turntable with a low-output MC cartridge to the PHONO jack, use an in-line boosting transformer or MC-head amplifier.
- Connect your turntable to the GND terminal of this unit to reduce noise in the signal.
- We recommend connecting the coaxial digital output terminal of a CD player to the AV3 jack.

### About audio/video output jacks

Among the analog audio and analog video signals input to this unit via input terminals, the audio/video signals of the selected input sources are output from the AV OUT jack and AUDIO OUT jack. An HDMI input signal, COMPONENT VIDEO input signal or digital audio input signal cannot be output. When using the AV OUT jacks or AUDIO OUT jacks, connect them as follows:

**When using the AV OUT jacks:** connect them to composite video and analog audio input jacks of an external component.

**When using the AUDIO OUT jacks:** connect them to analog audio jacks of an external component.

## Connecting a multi-format player or an external decoder

This unit has 8 sets of input jacks (FRONT L/R, CENTER, SURROUND L/R, SUR. BACK and SUBWOOFER) to input multi-channel analog sound signals. If your playback component, such as a DVD player or SACD player, has multi-channel analog output capability, you can enjoy up to 7.1-channel multi-channel sound. To output multi-channel sound, connect the audio output jacks of your playback component to the MULTI CH INPUT jacks of this unit, and set the input source of this unit to "MULTI CH." For details on how to change input sources, see page 24.

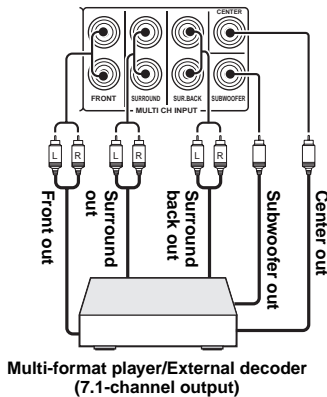

### Notes

- When you select "MULTI CH" as the input source, the digital sound field processor is automatically disabled.
- Since this unit does not redirect signals input at the MULTI CH INPUT jacks to accommodate for missing speakers, connect at least a 5.1-channel speaker system when using this feature.
- When the input source is switched to "MULTI CH," images input from a component connected to "AV1-6" or "V-AUX" can be displayed on a video monitor (see page 39). If your DVD player does not support multi-channel digital output, connect it to these input jacks.

## Connecting an external amplifier

The same channel signals are output from the jacks of the PRE OUT terminals as from their corresponding SPEAKERS terminals. When connecting an external power amplifier (pre-main amplifier) to enhance speaker output, connect the input terminals of the power amplifier to the PRE OUT terminals of this unit.

### Note

- When a component is connected to the PRE OUT terminals, do not connect speakers to the SPEAKERS terminals corresponding to those PRE OUT terminals.

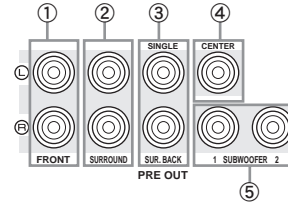

- FRONT (PRE OUT) jacks**  
Front channel output jacks.
  - SURROUND (PRE OUT) jacks**  
Surround channel output jacks.
  - SUR. BACK (PRE OUT) jacks**  
Surround back output jacks. When you only connect one external amplifier for the surround back channel, connect it to the SUR. BACK (SINGLE) jack.
- ☼
- To output surround back channel signals through these jacks, set "Sur.B L/R SP" to any parameter except for "None" in "Speaker Setup" (see page 46).
- CENTER (PRE OUT) jack**  
Center channel output jack.
  - SUBWOOFER (PRE OUT) 1/2 jack**  
Connect a subwoofer with a built-in amplifier. When two subwoofers are connected, the same sound is output from them.

## Using REMOTE IN/OUT jacks

When the components are the Yamaha products and have the capability of the transmission of the remote control signals, connect the REMOTE IN and REMOTE OUT jacks to the remote control input and output jack with the monaural analog mini cable as follows.

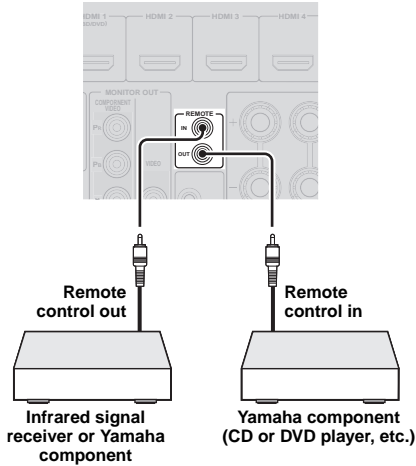

- If your Yamaha component supports the SCENE link playback function, remote connection automatically starts playback when you press **SCENE** (or **SCENE**) to select a SCENE.
- If the component connected to the REMOTE OUT jack is not a Yamaha product, set "SCENE IR" in the ADVANCED SETUP menu to "OFF" (see page 55).

## Connecting a Yamaha iPod universal dock or Bluetooth™ wireless audio receiver

This unit has the DOCK jack, to which you can connect a Yamaha iPod universal dock (YDS-11, sold separately) or a Bluetooth wireless audio receiver (YBA-10, sold separately). You can play an iPod or a Bluetooth component with this unit by connecting it to the DOCK jack.

Use a dedicated cable for connection between the dock/receiver and this unit.

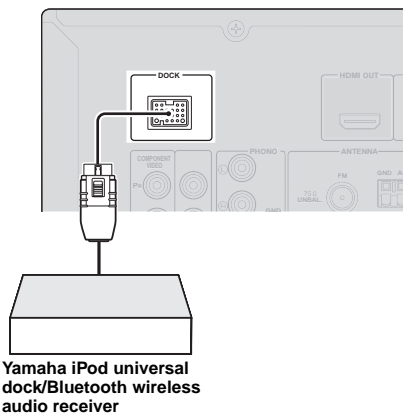

## Connecting a camcorder or portable audio player

The V-AUX terminals on the front panel are useful for connecting a camcorder, a game console or a portable music player to this unit. Be sure to turn down the volume of this unit and other components before making connections.

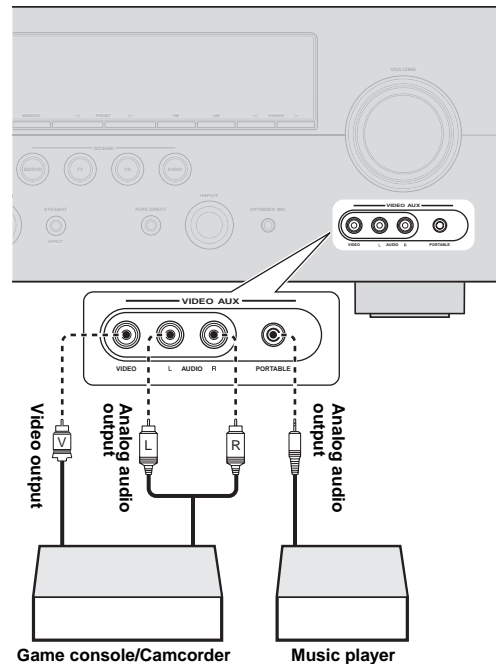

- To connect a component to the PORTABLE jack, use a 3.5 mm stereo mini plug cable.
- When external components are connected both the PORTABLE jack and AUDIO jack, sound input from the PORTABLE jack is output.

## Connecting the FM and AM antennas

An indoor FM antenna and an AM loop antenna are supplied with this unit. Connect these antennas properly to the respective jacks.

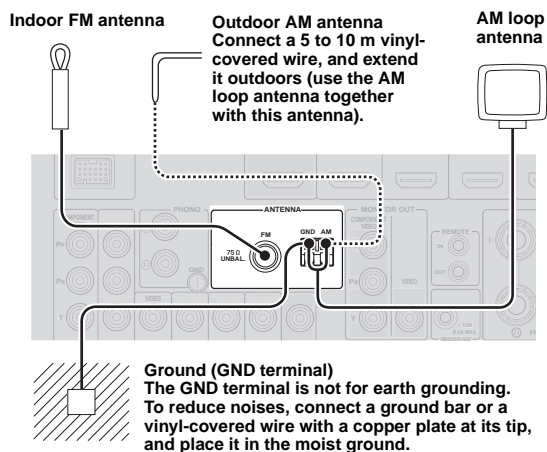

- The supplied antennas are normally sensitive enough to obtain good reception.
- Position the AM loop antenna away from this unit.
- If you cannot get good reception, we recommend that you use an outdoor antenna. For more details, consult the nearest authorized Yamaha dealer or service center.
- Always use the AM loop antenna even when the outdoor antenna is connected.

### Assembling the AM loop antenna

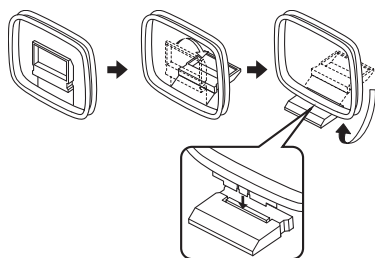

### Connecting the AM loop antenna

The wires of the AM loop antenna have no polarity. You can connect either wire to the AM terminal and the other to the GND terminal.

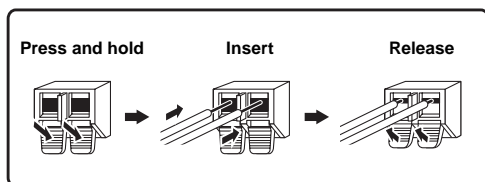

## Connecting the power cable

After all connections are complete, plug the AC power cable of this unit into an AC wall outlet.

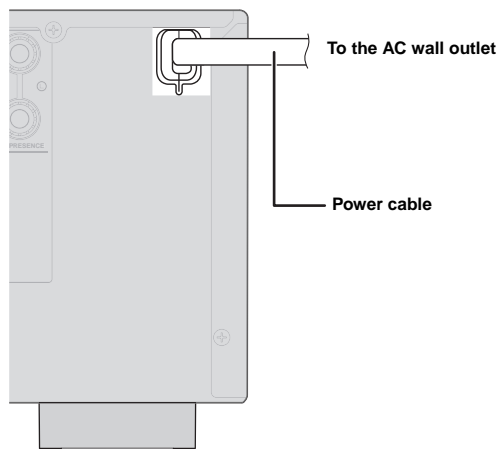

## Turning this unit on and off

- 1 Press **(A) MAIN ZONE ON/OFF** (or **(16) POWER**) to turn on this unit.
- 2 Press **(A) MAIN ZONE ON/OFF** (or **(16) POWER**) again to turn off this unit (standby).



- This unit needs a few seconds until ready to play back.
- You can also turn on this unit by pressing **(M) SCENE** (or **(9) SCENE**).
- This unit consumes a small amount of electricity even during standby.

We recommend disconnecting the power cable from the AC wall outlet.

### Caution

Do not unplug this unit while it is turned on. Doing so may damage this unit or cause the settings of this unit to be saved incorrectly.

# Optimizing the speaker setting for your listening room (YPAO)

This unit has a Yamaha Parametric Room Acoustic Optimizer (YPAO). With the YPAO, this unit automatically adjusts the output characteristics of your speakers based on speaker position, speaker performance, and the acoustic characteristics of the room. We recommend that you first adjust the output characteristics with the YPAO when you use this unit.

## Notes

- Loud test tones may be output during the automatic setup procedure. Do not allow small children to enter the room during the procedure.
- To achieve the best results, make sure the room is as quiet as possible while the automatic setup procedure is in progress. If there is too much ambient noise, the results may not be satisfactory.



- You can manually adjust the output characteristics of your speakers with "2 Manual Setup" in the SETUP menu. For details, see page 45.

"MIC ON. View OSD MENU" appears on the front panel display. The following menu screen appears on the video monitor.

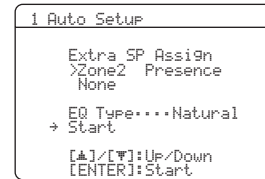

- You can bring up the above menu screen from the SETUP menu (see page 45).

## Using Auto Setup

### 1 Check the following points.

Before starting the automatic setup, check the following.

- All speakers and subwoofer are connected properly.
- Headphones are disconnected from this unit.
- The video monitor is connected properly.
- This unit and the video monitor are turned on.
- This unit is selected as the video input source of the video monitor.
- The connected subwoofer is turned on and the volume level is set to about half way (or slightly less).
- The crossover frequency controls of the connected subwoofer are set to the maximum.

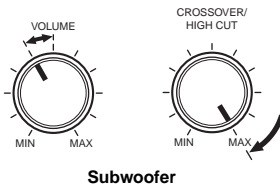

### 2 Connect the supplied optimizer microphone to the OPTIMIZER MIC jack on the front panel.

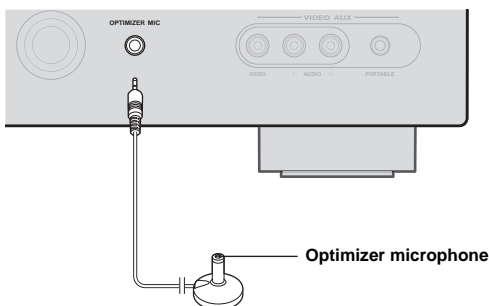

### 3 Place the optimizer microphone at your normal listening position on a flat level surface with the omni-directional microphone heading upward.

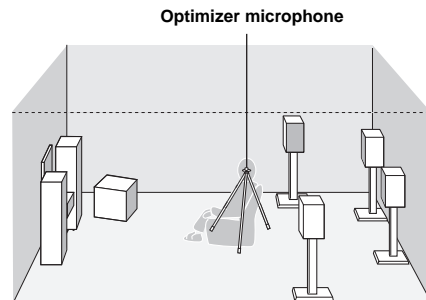

- It is recommended that you use a tripod or something similar to fix the optimizer microphone at the same height as your ears would be when seated in your listening position. You can fix the optimizer microphone to the tripod with the attaching screw of the tripod.

### 4 When the speakers are connected to EXTRA SP jacks, press **[Cursor Δ]** repeatedly to select "Extra SP Assign," and then press **[Cursor < / >]** to select how to use EXTRA SP jacks from "Zone2," "Presence" or "None."

If this unit does not work when you press **[Cursor Δ]**, press **[SETUP]** once and then operate this unit.

**5 To select a sound character for adjustment, press [F1]Cursor ▾ to select “EQ Type” and then press [F1]Cursor </>.**

If this unit does not work when you press [F1]Cursor, press [F10]SETUP once and then operate this unit. This unit has a parametric equalizer that adjusts the output levels for each frequency range. The equalizer is adjusted to produce a cohesive sound field based on automatically measured speaker characteristics. In “EQ Type,” you can select the following parametric equalizer characteristics suitable for the desired sound characteristics.

**Natural**

Adjusts all speakers to achieve natural sound. Select this if sounds in the high frequency range seem too strong when “EQ Type” is set to “Flat.”

**Flat**

Adjusts each speaker to obtain the same characteristics. Select this if your speakers have similar qualities.

**Front**

Adjusts each speaker to obtain the same characteristics as the front left and right speakers. Select this if your front left and right speakers have significantly better qualities than the other speakers.

**6 Press [F1]Cursor ▾ to select “Start” and then press [F1]ENTER to start the setup procedure.**

A countdown starts and a measurement starts in 10 seconds. A loud test tone is output during measurement.

**Notes**

- During the automatic setup procedure, do not perform any operation on this unit.
- To cancel the automatic setup procedure, press [F1]Cursor △.

Measurement takes about 3 minutes. To obtain precise results, stay where you will not disturb the measurement, such as to the side of or behind the speakers or outside the room.

When measurement is successfully completed, “YPAO Complete” appears on the front panel display and the results appear on the video monitor.

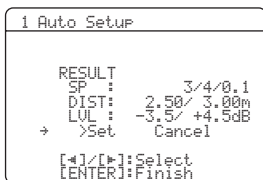

**SP**

Displays the number of speakers connected to this unit in the following order:  
Total of Front, Center, and Presence/Total of Surround and Surround Back/Subwoofer

**DIST**

Displays the speaker distance from the listening position in the following order:

Closest speaker distance/Farthest speaker distance

**LVL**

Displays the speaker output levels in the following order:  
Lowest speaker output level/Highest speaker output level

**Notes**

- If “ERROR” appears on the video monitor during the automatic setup procedure, measurement is canceled and the type of error is displayed. For details, see “When an error message is displayed during measurement” (see page 23).
- If problems occur during measurement, “WARNING (XX)” (xx indicates the number of warning) appears above “RESULT” (see page 23).

**7 Press [F1]ENTER.**

The speaker characteristics are adjusted according to measurement results.

To cancel the operation, press [F1]Cursor </> to select “Cancel” and press [F1]ENTER.

When the following screen appears, remove the optimizer microphone. The automatic setup procedure is now complete.



The optimizer microphone is sensitive to heat. Store it in a cool place and away from direct sunlight after measurement. Do not leave it in a place where it will be subjected to high temperatures such as on an AV component.

**☀**

- If you do not want to apply the measurement results, select “Cancel.”
- Perform the automatic setup procedure again if you change the number or positions of speakers.
- If you press [F1]ENTER before removing the optimizer microphone, “1 Auto Setup” of “Speaker Setup” in the SETUP menu (see page 45) is displayed.



## When an error message is displayed during measurement

Press **[F1]Cursor** **▽** once, and select “Retry” or “Exit” using **[F1]Cursor** **</>** and then press **[F1]ENTER**.

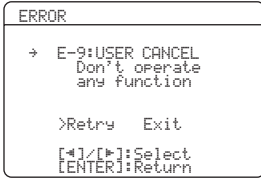

### Retry

Performs the automatic setup procedure again.

### Exit

Terminates the measurement and the automatic setup procedure.



- See page 63 for details on error messages.
- When “E-5:NOISY” appears, you can continue measurement. To continue measurement, select “Proceed.” However, we recommend that you solve the problem first and then perform measurement again.

## When a warning message is displayed after measurement

If a problem occurs during measurement, “WARNING” is displayed on the result display screen. Check the error and solve the problems.

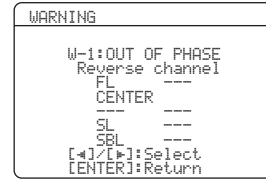

- See page 64 for details on warning messages.
- Optimization will not be performed while a warning message is displayed. We recommend that you solve the problem and perform the automatic setup procedure again.

**1** If “→” is displayed on the left of “WARNING” on the result display screen, press **[F1]ENTER**.

Details of the warning message are displayed. If there are multiple warning messages, you can display the next message using **[F1]Cursor** **>**.

**2** To return to the top result display, press **[F1]ENTER** again.

# BASIC OPERATION

## Playback

### Basic procedure

- 1 Turn on external components (TV, DVD player, etc.) connected to this unit.
- 2 Rotate the **INPUT selector** (or press the **Input selection keys**) to select an input source.

The name of the selected input source is displayed for a few seconds.

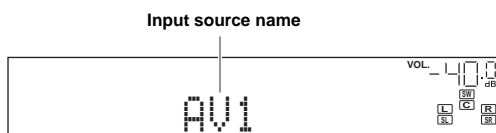

- You can change the input source name displayed on the front panel display or on the video monitor as necessary (see page 50).

- 3 Play the external component that you have selected as the source input, or select a radio station on the tuner.

Refer to the instruction manuals provided with the external component for details on playback. For selecting radio stations or playback of an iPod or Bluetooth component using this unit, see the following.

- Using iPod (see page 33)
- Using Bluetooth components (see page 35)

- 4 Turn the **VOLUME control** to adjust the volume (or press **VOLUME +/-**).

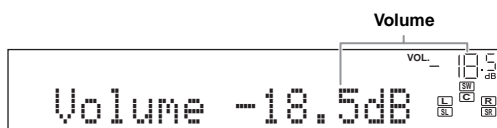

#### Note

When you play back a DTS-CD, noise may be output in some conditions, which may cause a speaker malfunction. Make sure that the volume is set to low before starting playback. If noise is output, do the following.

1) When only noise is output

If a DTS bitstream signal is not properly input to this unit, only noise is output. Connect the playback component to this unit by digital connection and play back the DTS-CD. If the condition is not improved, the problem may result from the playback component. Consult the manufacturer of the playback component.

2) When noise is output during playback or skip operation  
Before playing back the DTS-CD, display the OPTION menu after selecting the input source and set "Decoder Mode" to "DTS" (see page 38).

### Using the SCENE function

This unit has four SCENE keys that allow you to change input sources and sound field programs with one key. A set of input source and sound program suitable for a certain situation, such as playing back movies or music, is assigned to each key by default.

	Input source	Sound field program
BD/DVD	HDMI1	Straight
TV	AV1	Straight
CD	AV3	Straight
RADIO	TUNER	7ch Enhancer



- This unit turns on when **SCENE** (or **SCENE**) is pressed during standby.
- If a Yamaha DVD player that can receive SCENE control signals is connected to the REMOTE OUT jack of this unit, the DVD player automatically turns on and starts playback when **SCENE** (or **SCENE**) is pressed (see page 19). For details, refer to the instruction manual of the DVD player.

### Selecting a SCENE

Press **SCENE** (or **SCENE**).

### Registering input source/sound field program

Select the desired input source/sound field program, and press down **SCENE** (or **SCENE**) until "SET Complete" appears on the front panel display.

When the OSD is displayed on the video monitor, "SCENE Setting Complete" appears on the video monitor.



- If you are using the remote control for an external component, set that external component too whenever SCENE setting is performed. For more details, see the next section.

## Switching remotely controlled external components linked to SCENE selections

You can operate an external component with the remote control of this unit by setting a remote control code for the external component for each input source. Setting remote control codes for desired input sources allows you to switch between external components linked to SCENE selections.

When you change the SCENE key settings, change settings of the external component as well by following the steps below.

- 1 Register the remote control code of an external component to the desired input source (see page 53).

### Note

- Remote control codes cannot be registered to TUNER input sources.

- 2 Press **[5]** Input selection keys on the remote control for the input source whose remote control code was registered in step 1 for about 3 seconds while pressing down **[9]** SCENE key whose assignment you want to change.

The external component can now be controlled remotely just by selecting the **[9]** SCENE key.

## Muting audio output temporarily (MUTE)

- 1 Press **[21]** MUTE on the remote control to mute the audio output.  
The MUTE indicator on the front panel display flashes while audio output is muted.
- 2 Press **[21]** MUTE again to resume audio output.

## Adjusting high/low frequency sound (tone control)

You can adjust the balance of the high frequency range (Treble) and low frequency range (Bass) of sounds output from the front left and right speakers to obtain desired tone.



- The tone control of the speakers or headphones can be set separately. Set the headphone tone control with the headphones connected.

- 1 Press **[N]** TONE CONTROL on the front panel repeatedly to select “Treble” or “Bass.”

The current setting is displayed on the front panel display.



- 2 Rotate the **[C]** PROGRAM selector to adjust the output level in those frequency ranges.

Adjustable range: -10.0 dB to +10.0 dB

The display returns to the previous screen soon after you release the selector.

### Notes

- The tone control settings are not effective during playback in Pure Direct mode.
- If you set the balance extremely off, sounds may not match those from other channels well.

## Enjoying pure hi-fi sound (Pure Direct mode)

Use Pure Direct mode to enjoy the pure high fidelity sound of the selected source. When Pure Direct mode is activated, this unit plays back the selected source with the least circuitry.

Press **[Q]** PURE DIRECT (or **[8]** PURE DIRECT) to turn the Pure Direct mode on or off.

The following features are disabled in Pure Direct mode.

- sound field program and tone control
- display and operation of the OPTION menu and SETUP menu
- multi-zone function



- The front panel display turns off in Pure Direct mode. It turns on again when Pure Direct mode is turned off.

## Using your headphones

### Plug your headphones in the **PHONES** jack on the front panel.

When you select a sound field program while using the headphones, the mode is automatically set to SILENT CINEMA mode.

#### Notes

- When you connect headphones, no signals are output from the SPEAKERS terminals.
- When multi-channel signals are processed, sounds in all channels are divided to left and right channels. When the input source is set to "MULTI CH," only front L/R sound is output from the headphones.

## Displaying input signal information

When HDMI-4 or AV1-4 is selected as the input source, you can display audio/video signal information.



- Input signal information is displayed on both a video monitor and the front panel display.

### 1 Select the desired input source, and press **OPTION**.

The OPTION menu for the selected input source is displayed (see page 37).

### 2 Press **Cursor** $\Delta$ / $\nabla$ to select "Signal Info," and press **ENTER**.

Information on input signals is displayed. See page 38 on information displayed on the screen.



- You can change items of information displayed on the front panel display using **Cursor**  $\Delta$  /  $\nabla$ .
- If an HDMI related error occurs, error information is displayed at the bottom of the screen.

### 3 To end the information display, press **OPTION**.

## Changing information on the front panel display

You can display information on the front panel display such as the names of the currently selected sound field program and surround decoders on the front panel display. To change the display, press **INFO** (or **INFO**) repeatedly. The following information can be displayed on the front panel display.

- Currently selected input source name (Input)
- Currently selected sound field program name (DSP Program)
- Currently selected surround decoder (Audio Decoder)
- Currently set FM/AM tuner frequency (Frequency)
- iPod playback information (Song, Album, Artist, List)

For example, if you select HDMI1 and display "DSP Program," the following screen appears on the front panel display.

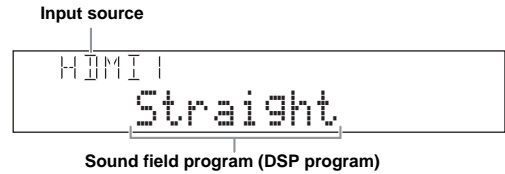

The information on each input source that can be displayed is shown in the table below.

Input source	Items
HDMI-4	Input
AV1-6	DSP Program
AUDIO1-2	Audio Decoder
V-AUX	
PHONO	
MULTI CH	Input
FM/AM	Frequency DSP Program Audio Decoder
iPod (Simple remote mode)	Input DSP Program Audio Decoder
iPod (Menu browse mode)	(Play information display) Artist Album Song DSP Program Audio Decoder (Play menu display) List
Bluetooth	Input DSP Program Audio Decoder

# Enjoy the sound field programs

This unit is also equipped with a Yamaha digital sound field processing (DSP) chip. You can enjoy multi-channel sounds for almost all input sources using various sound field programs stored on the chip and a variety of surround decoders.

## Selecting sound field programs

### ■ Selecting a sound field program on the front panel

Rotate the **PROGRAM selector** to select a desired sound field program.

### ■ Selecting a sound field program with the remote control

Perform the following operations depending on the category of the sound field programs.

- Sound field programs for movies/TV programs..... Press **[8] MOVIE** repeatedly.
  - Sound field programs for music ..... Press **[8] MUSIC** repeatedly.
  - Stereo reproduction ..... Press **[8] STEREO** repeatedly.
  - Multi-channel stereo reproduction ..... Press **[8] STEREO** repeatedly.
  - Compressed Music Enhancer ..... Press **[8] STEREO** repeatedly.
  - Surround decoder ..... Press **[8] SUR. DECODE** repeatedly.
- For example, if you select “Sci-Fi” in “MOVIE,” the following screen appears on the front panel display.

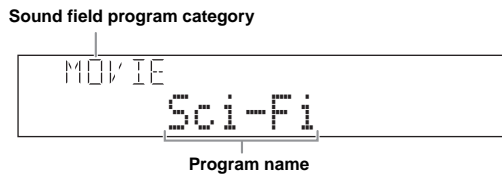

### Notes

- Sound field programs are stored for each input source. When you change the input source, the sound field program previously selected for that input source is applied again.
- When you play back the Dolby Digital Plus, Dolby TrueHD, DTS Express, DTS-HD Master Audio, or DTS-HD High Resolution Audio sources, sound is reproduced in straight decode mode.
- If the sampling frequency of an input source is higher than 96 kHz, this unit does not apply any sound field programs.

## Sound field program descriptions

This unit provides sound field programs for multiple categories including music, movies and stereo reproduction. Select a sound field program based on your listening preference, not merely on the name of the program, etc.



- You can check what speakers are currently outputting signals with the speaker indicators on the front panel display (see page 6).
- Each program can adjust sound field elements (sound field parameters). For details, see page 40.
- **CINEMA DSP** in the table indicates the sound field program with CINEMA DSP.

### For movie/TV program sources (MOVIE) **CINEMA DSP**

Program	Descriptions
<b>Standard</b>	Creates a sound field that emphasizes the surrounding feeling without disturbing the original acoustic positioning of multi-channel audio such as Dolby Digital and DTS. The design concept of this sound field is “an ideal movie theater,” in which the audience is surrounded by beautiful reverberations from the left, right and rear.
<b>Spectacle</b>	Creates a spectacular sound field that produces a sense of magnificent scale. This sound field program features a wide dynamic range that reproduces a broad theater sound field matching cinemascope and wider-screen movies, from tiny sound effects to big acoustics.
<b>Sci-Fi</b>	Creates a clear sound field that allows you to enjoy the finely elaborated sound design of the latest science fiction and SFX movies. Different atmospheres can be vividly reproduced while dialog, sound effects and background music are clearly separated.
<b>Adventure</b>	Creates a sound field ideal for action and adventure movies, reproducing a sense of power by reducing reverberations and emphasizing a horizontal soundscape. A clear and powerful atmosphere is reproduced while maintaining separation of audio channels and sound clarity with a shallower depth of feeling.

Program	Descriptions
<b>Drama</b>	Creates a calm sound field suitable for different genres of movies, from serious dramas to musicals and comedies. Sound is produced with discreet reverberation yet with a three-dimensional feeling. Spatial sound effects and background music are reproduced with soft reverberations around the center position, which reduces fatigue from watching movies for a long time.
<b>Mono Movie</b>	Creates a sound field that allows you to enjoy old monaural movies in an atmosphere of a movie theater of those days. A comfortable space with a feeling of depth is reproduced by adding soundscape and reasonable reverberation to the original sound.
<b>Sports</b>	Creates a lively sound field suitable for stereo sports broadcasts and TV studio shows. In sports broadcasts, the voices of sports commentators and analysts are output from the center while the crowd's cheers and other sounds are suitably spread out, creating a realistic stadium atmosphere that makes you feel as if you are really there.
<b>Action Game</b>	Creates a sound field designed for action games such as car racing and FPS games. The presence of various sound effects is enhanced while maintaining a clear feeling of direction by limiting each channel's sound effect range using reflection data, which produces a realistic and powerful playing environment.
<b>Roleplaying Game</b>	Creates a sound field designed for roleplaying games and adventure games. Depth and a three-dimensional feel to the game are produced by combining movie sound field effects and the sound design used in "Action Game." In movie scenes, movie-like surround effects are produced.

**For audio music sources (MUSIC)**



Program	Descriptions
<b>Hall in Munich</b>	Creates a sound field designed by simulating a concert hall with about 2,500 seats in Munich, which is a typical European concert venue with elegant wooden interior walls. A rich, delicate and beautiful sound is produced, creating a relaxing atmosphere. The seat setting is a left center orchestra seat.
<b>Hall in Vienna</b>	Creates a sound field designed by simulating a concert hall with about 1,700 seats in Vienna, which is a traditional middle-size shoebox type concert venue. In this hall, complex omnidirectional reflections bounce off pillars and carvings to produce a characteristically rich sound.
<b>Chamber</b>	Creates a sound field designed by simulating a relatively large room with a high ceiling such as a palace chamber. It produces pleasant reverberations suitable for court music and chamber music.
<b>Cellar Club</b>	Creates a realistic live sound field designed by simulating a live house with a low ceiling and intimate atmosphere. It features a powerful sound that makes you feel as if you are right in front of a small stage.
<b>The Roxy Theatre</b>	Creates a sound field designed by simulating a rock music live house with up to about 460 seats in Los Angeles. The seat setting is a left center seat.
<b>The Bottom Line</b>	Creates a sound field designed by simulating "The Bottom Line," a famous New York jazz club which has a floor occupied by 300 wide seats. It produces clear reverberations. The seat setting is in front of the stage.
<b>Music Video</b>	Creates a sound field designed by simulating a concert venue where live performances of pop, rock and jazz music take place. You can indulge yourself in a hot live atmosphere created by a presence sound field that emphasizes the vividness of vocals and solos and the beat of the drums, and by a surround sound field that reproduces a big live venue atmosphere.

**For stereo reproduction (STEREO)**

Program	Descriptions
<b>2ch Stereo</b>	Produces front stereo sound. This is standard playback mode.



- When multi-channel signals are input, they are downmixed to 2 channels and output from the front left and right speakers.

**For multi-channel stereo reproduction (STEREO)**



Program	Descriptions
<b>7ch Stereo</b>	Produces front and rear sound for a large area. This playback mode is suitable for BGM at a house party. Sound is output from a maximum of seven speakers.

## The Compressed Music Enhancer (ENHNCR)

Program	Descriptions
<b>Straight Enhancer</b>	Dynamically reproduces sound from 2-channel or multi-channel compressed sound data with the same number of channels as its source sound.
<b>7ch Enhancer</b>	Dynamically reproduces sound from compressed sound data in 7 channels regardless of the source sound channels.

## Surround decode mode (SUR.DEC)

Reproduces sound from 2-channel sound sources in up to 7 channels using a surround decoder.

Decoder	Descriptions
<b>Pro Logic</b>	Reproduces sound using the Dolby Pro Logic decoder. This is suitable for all kinds of sound sources.
<b>PLIIx Movie / PLII Movie</b>	Reproduces sound using the Dolby Pro Logic IIx (or Dolby Pro Logic II) decoder. This is suitable for movies. You cannot select the Dolby Pro Logic IIx decoder in the following conditions: <ul style="list-style-type: none"> <li>• When no surround back speakers are connected</li> <li>• When headphones are connected</li> </ul>
<b>PLIIx Music / PLII Music</b>	Reproduces sound using the Dolby Pro Logic IIx (or Dolby Pro Logic II) decoder. This is suitable for music. You cannot select the Dolby Pro Logic IIx decoder in the following conditions: <ul style="list-style-type: none"> <li>• When no surround back speakers are connected</li> <li>• When headphones are connected</li> </ul>
<b>PLIIx Game / PLII Game</b>	Reproduces sound using the Dolby Pro Logic IIx (or Dolby Pro Logic II) decoder. This is suitable for games. You cannot select the Dolby Pro Logic IIx decoder in the following conditions: <ul style="list-style-type: none"> <li>• When no surround back speakers are connected</li> <li>• When headphones are connected</li> </ul>
<b>Neo:6 Cinema</b>	Reproduces sound using the DTS Neo:6 decoder. This is suitable for movies.
<b>Neo:6 Music</b>	Reproduces sound using the DTS Neo:6 decoder. This is suitable for music.



- When multi-channel sound is input, sound is reproduced in straight decoding mode (see page 30).

## Enjoying unprocessed input sources (Straight decoding mode)

In straight decoding mode, sounds are reproduced without sound field effect. 2-channel stereo sources are output from only the front left and right speakers. Multi-channel input sources are decoded straight into the appropriate channels and multi-channel sounds are reproduced without a sound field effect.

**1 To enable straight decoding mode, press**  
Ⓟ **STRAIGHT** (or Ⓜ **STRAIGHT**).

“Straight” appears on the front panel display.

**2 To cancel straight decoding mode, press**  
Ⓟ **STRAIGHT** (or Ⓜ **STRAIGHT**) again.

A sound field program name appears on the front panel display, and sound is reproduced with that sound field effect.

## Enjoying sound field programs without surround speakers (Virtual CINEMA DSP)

Virtual CINEMA DSP allows you to enjoy DSP sound field surround effects even without any surround speakers by using virtual surround speakers. You can even enjoy Virtual CINEMA DSP using a minimal two-speaker system that does not include a center speaker. When “Sur. L/R SP” in the SETUP menu is set to “None” (see page 46), this unit operates in Virtual CINEMA DSP mode.

### Note

- Virtual CINEMA DSP is not available in the following conditions even if you set “Sur. L/R SP” to “None” (see page 46).
  - headphone plug is connected to the PHONES jack.
  - 7ch Stereo of the field sound program is selected.
  - Pure Direct mode or straight decoding mode is used.

## Enjoy sound field programs with headphones (SILENT CINEMA™)

SILENT CINEMA allows you to enjoy multi-channel sources with your headphones. SILENT CINEMA mode is automatically selected when you connect the headphone plug to the PHONES jack.

### Note

- SILENT CINEMA mode is not available in the following conditions.
  - 2ch Stereo of the sound field program is selected.
  - Pure Direct mode or straight decoding mode is selected.

## Enjoying more spatial sound fields (CINEMA DSP 3D mode)

CINEMA DSP 3D mode creates an intensive and accurate stereoscopic sound field in the listening room.

To use this unit in CINEMA DSP 3D mode, presence speakers are required. Do the following steps and then select a CINEMA DSP sound field program. When a sound field program runs in CINEMA DSP 3D mode, the CINEMA DSP 3D indicator on the front panel lights up.

- Connect the presence speakers to the EXTRA SP jacks (see page 12).
- Set “Extra SP Assign” to “Presence” (see page 45).
- Enable CINEMA DSP 3D in the SETUP menu (see page 40).

### Note

- If headphones are connected to this unit, this unit plays back in SILENT CINEMA mode so CINEMA DSP 3D mode cannot be enabled.



# FM/AM tuning

The FM/AM tuner of this unit provides the following two modes for tuning.

## ■ Frequency tuning mode

You can tune into a desired FM/AM station by searching or specifying its frequency.

## ■ Preset tuning mode

You can preset the frequencies of FM/AM stations by registering them to specific numbers, and later just select those numbers to tune in.

### Note

- Adjust the FM/AM antennas connected to this unit for the best reception.

## Tuning into the desired FM/AM station (Frequency tuning mode)

- 1 Rotate the **ⓇINPUT** selector (or press **ⓂTUNER**) to switch the input source to "TUNER."
- 2 Press **ⓁFM** (**ⓂFM**) or **ⓁAM** (**ⓂAM**) to select a band.  
"FM" or "AM" appears on the front panel display according to the band that you have selected.
- 3 Press **ⓂTUNING** **◀ / ▶** (or **ⓂTUNING** **△ / ▽**) to specify the frequency.  
To adjust the frequency to a higher range, press **▶** (or **△**). To adjust it to the lower range, press **◀** (or **▽**). The TUNED indicator on the front panel display lights up when the tuner is tuned into a station. The STEREO indicator also lights up if the program being broadcasted is in stereo.

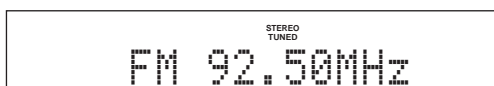

The frequency changes in the following manner according to how you press **ⓂTUNING** **◀ / ▶** (or **ⓂTUNING** **△ / ▽**).

### When you press the key more than 1 second

The tuner searches the frequency of a station that is detectable around the current frequency. This is effective when the tuner can receive strong signals without any interference. Once the search starts, release the key.

### When you press and release the key

The tuner increases or decreases the frequency in steps. Use this method when the tuner cannot receive strong signals and stations are skipped during the search.



- You can switch between stereo and monaural for FM broadcast in the OPTION menu (see page 39).

- 4 To tune in by direct frequency tuning, enter the frequency of the desired station using **ⓂNumeric keys** on the remote control.

Enter only integers. For example, if you want to set the frequency to 88.90 MHz, enter "8890" using **ⓂNumeric keys**.

### Notes

- When you press **ⓂNumeric keys** during preset tuning, a preset number is selected. Set tuning mode to frequency tuning mode using **ⓂTUNING** **◀ / ▶** (or **ⓂTUNING** **△ / ▽**) prior to the operation.
- "Wrong Station!" appears on the front panel display when you enter a frequency that is out of receivable range. Make sure that the entered frequency is correct.
- You do not need enter zero if it comes at the end of a decimal number. For example, enter "925" for "92.50 MHz" or "940" for "94.00 MHz."

## Registering FM/AM stations and tuning in (Preset tuning mode)

You can register up to 40 FM/AM stations (Preset) using the automatic station preset feature or manual station preset feature.

### Registering stations by automatic station preset

The tuner automatically detects FM stations with strong signals and registers up to 40 stations. AM stations cannot be automatically registered. Use manual station preset.

- 1 Rotate the **ⓇINPUT** selector (or press **ⓂTUNER**) to switch the input source to "TUNER."

- 2 Press **ⓂOPTION** on the remote control.

The OPTION menu screen for setting options of tuner input appears on the front panel display.



- For details on the OPTION menu, see page 37.
- The OPTION menu is displayed on the video monitor.

- 3 Select "Auto Preset," using **ⓂCursor** **△ / ▽** and press **ⓂENTER**.

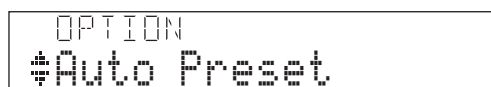

Automatic station preset starts about 5 seconds later from the lowest frequency upwards.



- You can select the preset number at which the preset starts by pressing **[6]PRESET**  $\Delta / \nabla$  or **[11]Cursor**  $\Delta / \nabla$  on the remote control while “READY” is displayed on the front panel display.
- To cancel registration, press **[11]RETURN** on the remote control.

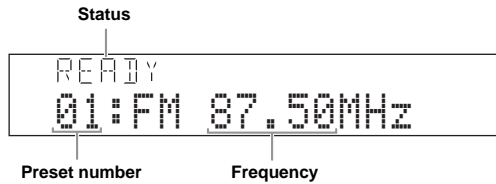

During the automatic station preset, the upper area of the screen changes as follows: SEARCH → MEMORY each time a station is registered.

When registration is complete, “FINISH” appears and the OPTION menu screen automatically reappears. When you press **[18]OPTION** on the remote control, the screen returns to the original state.

### Registering stations by manual station preset

You can manually register AM stations or FM stations with weak signals.

**1 Tune into a station referring to “Tuning into the desired FM/AM station (Frequency tuning mode)” (see page 31).**

**2 Press **[6]MEMORY** (or **[6]MEMORY**).**  
“Manual Preset” appears on the front panel display, followed soon by the preset number to which the station will be registered.



- By pressing down **[6]MEMORY** (or **[6]MEMORY**) for more than 2 seconds, you can skip step 3. The station is registered to the lowest empty preset number or a preset number one higher than the last preset number.

**3 Press **[H]PRESET**  $\triangleleft / \triangleright$  (or **[6]PRESET**  $\Delta / \nabla$ ) to select the preset number to which the station will be registered.**

When you select a preset number to which no station is registered, “Empty” appears on the display. When you select a registered preset number, a registered frequency is displayed on the right of the preset number.

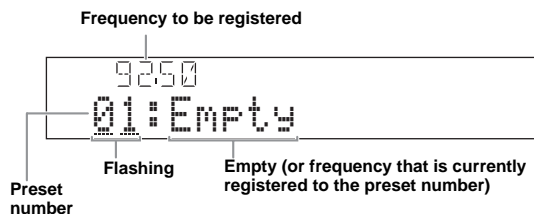

- You can select a preset number using the **[13]Numeric keys**.

**4 Press **[G]MEMORY** (or **[6]MEMORY**) again to register.**

When registration is complete, the screen returns to the original state.



- To cancel registration, press **[11]RETURN** on the remote control or leave the tuner without any operations for about 30 seconds.

### Calling a preset station (Preset tuning)

You can call preset stations registered by automatic station preset or manual station preset.

**Press **[H]PRESET**  $\triangleleft / \triangleright$  (or **[6]PRESET**  $\Delta / \nabla$ ) to select a preset number.**



- Preset numbers to which no stations are registered will be skipped.
- If no stations are registered, “No Presets” or “No Presets in Memory” appears on the display. See page 31 and register stations.
- You can directly select a preset number by pressing a **[13]Numeric keys** while calling a preset station. “Empty” appears on the display if you enter a preset number to which no station is registered. “Wrong Num.” appears if you enter an invalid number.
- When you press **[13]Numeric keys** during normal tuning, a preset number is selected. Set tuning mode to preset tuning mode using **[H]PRESET**  $\triangleleft / \triangleright$  (or **[6]PRESET**  $\Delta / \nabla$ ) prior to the operation.

### Clearing the preset station

**1 Rotate the **[R]INPUT selector** (or press **[5]TUNER**) to switch the input source to “TUNER.”**

**2 Press **[18]OPTION** on the remote control.**  
The OPTION menu screen for setting options of tuner input appears on the front panel display.

**3 Display “Clear Preset” using the **[11]Cursor**  $\Delta / \nabla$  and press **[11]ENTER**.**

The following screen appears on the display.

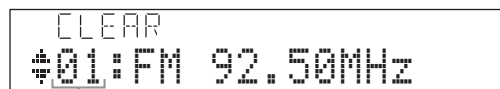

Preset number of the registered station you want to clear.



- You can cancel the operation and return to the OPTION menu screen by pressing **[11]RETURN** on the remote control.

**4 Select the preset number of the registered station you want to clear using the **[11]Cursor**  $\Delta / \nabla$  and press **[11]ENTER**.**

The preset station registered to the selected preset number is cleared. To clear the registration of multiple preset numbers, repeat the above steps. To end the operation, press **[18]OPTION**.

# Using iPod™

Once you have stationed your iPod in a Yamaha iPod universal dock (such as the YDS-11, sold separately) connected to the DOCK jack on the rear panel of this unit (see page 19), you can operate your iPod with the remote control of this unit using a menu displayed on the video monitor. You can also use the Compressed Music Enhancer mode of this unit to improve the sound quality of the compression artifacts (such as MP3 format) stored on your iPod (see page 29).

## Notes

- iPod touch, iPod (Click and Wheel including iPod classic), iPod nano, and iPod mini are supported.
- Some features may not be compatible depending on the model or the software version of your iPod.
- Some features may not be available depending on the model of Yamaha iPod universal dock. The following sections describe the procedure when using the YDS-11.



- Once the connection between your iPod and this unit is complete, "iPod connected" appears on the front panel display.
- For a complete list of status messages that appear on the front panel display and video monitor, see the "iPod" section on page 62.

## Controlling iPod™

You can control your iPod when you set it in the iPod universal dock and switch the input source to DOCK. The operations of your iPod can be done with the aid of the video monitor (menu browse mode) or without it (simple remote mode).

When you connect your iPod to this unit, you can perform the following operations with the remote control.

Key	Function
ENTER	Subsequent menu
△	Menu up
Ⓜ1 ▽	Menu down
◀	Previous menu
▶	Subsequent menu
◀◀	Search backward (Press and hold)
▶▶	Search forward (Press and hold)
▶▶▶	Skip forward
◀◀◀	Skip backward
Ⓜ2 □	Stop
⏸	Pause (Menu browse mode) Play/Pause (Simple remote mode)
▶	Play (Menu browse mode) Play/Pause (Simple remote mode)
Ⓜ20 DISPLAY	Switch between Menu browse mode and Simple remote mode

## Controlling iPod in simple remote mode

You can perform basic iPod operations (play, stop, skip, etc.) using the supplied remote control without displaying the menu on the video monitor. You can also directly control your iPod in this mode.

## Controlling iPod in menu browse mode

You can perform advanced iPod operations using the remote control while looking at the menu displayed on the video monitor. You can browse the song files or video files stored on your iPod and displayed on the monitor. You cannot directly control your iPod in this mode.



- “\_” (underscore) is displayed for characters that this unit cannot display.

**1** Rotate the **Ⓜ INPUT selector** (or press **Ⓜ5 DOCK** repeatedly) to select “iPod (DOCK)” as the input source.

**2** Press **Ⓜ20 DISPLAY** on the remote control. The following screen appears on the video monitor.



**3** Press **Ⓜ11 Cursor** △ / ▽ to select “Music” or “Videos” and press **Ⓜ11 Cursor** ▶.

- Select “Music” to browse music files.
- Select “Videos” to browse video files.

### Note

- “Videos” will not be displayed when your iPod or Yamaha iPod universal dock do not support the browser function for browsing video files.

- 4** Press **[11]Cursor**  $\Delta$  /  $\nabla$  /  $\triangleleft$  /  $\triangleright$  to select a menu item and then **[11]ENTER** to start playback.

#### Menu items of “Music”

Playlists, Artists, Albums, Songs, Genres, Composers

- Playlists > Songs
- Artists > Albums > Songs
- Albums > Songs
- Songs
- Genres > Artists > Albums > Songs
- Composers > Albums > Songs

#### Menu items of “Videos”

Menu items vary depending on the files stored on your iPod.

#### ■ Description of the play information display

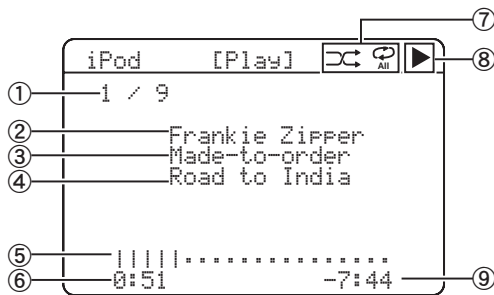

- ① Track number/total tracks
- ② Artist name
- ③ Album title
- ④ Song title
- ⑤ Progress bar
- ⑥ Elapsed time
- ⑦ Shuffle and repeat icons
- ⑧  $\blacktriangleright$  (playback),  $\parallel$  (pause),  $\blacktriangleright$  (search forward) and  $\blacktriangleleft$  (search backward)
- ⑨ Remaining time



- You can change information screens on the front panel display using **[E]INFO** (or **[7]INFO**) (see page 26). Items displayed on the front panel display vary depending on mode that is currently selected.

## Shuffle/repeat playback

You can use a special playback function such as shuffle playback and repeat playback by setting the OPTION menu.

- 1** Press **[20]DISPLAY** to switch to menu browse mode while “iPod (DOCK)” is selected as the input source.

To use the shuffle or repeat playback function in simple remote mode, set your iPod from its menu.

- 2** Press **[18]OPTION**.

The OPTION menu is displayed.

- 3** Press **[11]Cursor**  $\Delta$  /  $\nabla$  to select the desired playback function, “Shuffle” or “Repeat,” then press **[11]ENTER**.

The following playback styles are available depending on the playback function selected.

**Shuffle:** Plays back songs or albums in random order (Choices: Off, Songs, Albums).

- Select “Off” if you do not want to play back in random order.
- Select “Songs” to play back songs in random order.
- Select “Albums” to play back albums in random order.

**Repeat:** Plays back songs or albums repeatedly (Choices: Off, One, All).

- Select “Off” if you do not want to play back repeatedly.
- Select “One” to repeat each song.
- Select “All” to repeat all songs.

- 4** Select the desired style using **[11]Cursor**  $\triangleleft$  /  $\triangleright$ .

The style is selected. Playback starts with the function selected in step 3.

To return to the previous screen, press **[11]RETURN**. To return to the previous playback function, redo the above steps.



- When the shuffle function is on, “ $\square$ ” appears on the video monitor.
- When “Repeat” is set to “One” or “All,” “ $\square$ ” or “ $\square$ ” appears on the video monitor.

# Using Bluetooth™ components

This unit supports A2DP (Advanced Audio Distribution Profile) of the Bluetooth profile. You can connect a Yamaha Bluetooth wireless audio receiver (such as YBA-10, sold separately) to the DOCK jack of this unit and enjoy the music contents stored in your Bluetooth component (such as a portable music player) without wiring between this unit and the Bluetooth component. You need to perform “Pairing” the connected Bluetooth wireless audio receiver and your Bluetooth component in advance.

## Pairing the Bluetooth™ wireless audio receiver and your Bluetooth™ component

“Pairing” refers to the operation of registering a Bluetooth component for Bluetooth communications. Pairing must be performed when using a Bluetooth component with the Bluetooth wireless audio receiver connected to this unit for the first time or if the pairing data has been deleted.



- You only need the pairing operation for the first time that you use the Bluetooth component with the Bluetooth wireless audio receiver.
- Pairing requires operations on this unit and on the other component with which Bluetooth communications are to be established. If necessary, refer to the instruction manuals provided with other component.

### ■ Pairing the Bluetooth wireless audio receiver and your Bluetooth component

To ensure security, a time limit of 8 minutes is set for the pairing operation. We recommend that you read the instructions so that you fully understand them before starting.

#### 1 Rotate the **Ⓡ** INPUT selector (or press **5** DOCK repeatedly) to select “Bluetooth (DOCK)” as the input source.

#### 2 Turn on the Bluetooth component you want to pair with and set it to pairing mode.

For details on operation of the Bluetooth component, refer to its instruction manuals.

#### 3 Press **18** OPTION.

The OPTION menu for DOCK input appears on the video monitor.

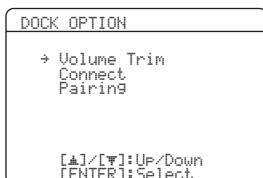

#### 4 Press **11** Cursor ▽ to select “Pairing” and press **11** ENTER.

“Searching” appears on the front panel display and the pairing operation starts.



- To cancel pairing, press **11** RETURN.
- You can also start pairing operation by pressing and holding **Ⓢ** MEMORY on the front panel.

#### 5 Make sure the Bluetooth component recognizes the Bluetooth wireless audio receiver.

If the Bluetooth have recognized the Bluetooth wireless audio receiver, “YBA-10 YAMAHA,” for instance, is displayed in the Bluetooth device list.

#### 6 Select the Bluetooth wireless audio receiver from the Bluetooth device list, and enter a path key “0000” into the Bluetooth component.

When pairing is complete, “Completed” appears on the front panel display.



- The Yamaha Bluetooth wireless audio receiver can be paired with up to eight Bluetooth components. When pairing is conducted successfully with a ninth component and the pairing data is registered, the pairing data for the least recently used other component is cleared.

## Playback of the Bluetooth™ component

#### 1 Rotate the **Ⓡ** INPUT selector (or press **5** DOCK repeatedly) to select “Bluetooth (DOCK)” as the input source.

#### 2 Press **18** OPTION.

#### 3 Press **11** Cursor ▽ repeatedly to select “Connect” and press **11** ENTER.

After you execute “Connect,” communication with the Bluetooth component is established. When the connected Bluetooth wireless audio receiver recognizes the Bluetooth component, “BT Connected” appears on the front panel display.



- When you press **11** ENTER on the remote control, the connected Bluetooth wireless audio receiver searches and connects to the last connected Bluetooth component. If the Bluetooth wireless audio receiver cannot find the Bluetooth component, “Not found” appears on the front panel display.
- To disconnect the Bluetooth wireless audio receiver from the Bluetooth component, display the OPTION menu again, select “Disconnect,” and press **11** ENTER.

#### 4 Start playback of the Bluetooth component.

# Other functions

## Using the sleep timer

You can set this unit to automatically return to standby after a set time has passed.

The sleep timer is useful if you want to go to sleep while this unit is playing or recording a source.

Press **[SLEEP]** repeatedly to set the amount of time.

Each time you press the key, the front panel display changes as shown below.

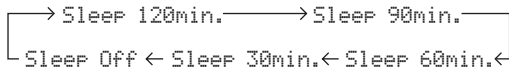

When the sleep timer is set, the SLEEP indicator on the front panel display lights up.

Press **[SLEEP]** on the remote control repeatedly until “Sleep Off” appears on the front panel display.

## Using the HDMI™ control function

This unit supports the HDMI control function.

When a TV that supports the HDMI control function is connected with this unit via the HDMI connection, the following operations of this unit can be controlled with the TV remote control (except for some TVs).

- Switching between on and standby (linked to the TV)
- Volume control (up/down, mute)
- Switching the sound output between a TV and this unit

When you use the HDMI control function, do the following referring to the instruction manuals of the TV.

- Turn on the HDMI control function on the TV.
- Connect the TV to this unit following the instructions for connecting the TV to an AV amplifier.



- The HDMI control-compatible components include Panasonic VIERA Link compatible TV, DVD player/recorder and Blu-ray Disc player.
- When a DVD recorder/Blu-ray recorder/HD DVD recorder that supports the HDMI control function is connected via the HDMI connection, its operations are also linked to those of this unit. For details, refer to its instruction manuals.
- We recommend that you use a TV, DVD recorder, Blu-ray recorder and HD DVD recorder of the same manufacturer.

**1 Connect a TV that supports the HDMI control function to this unit via the HDMI connection.**

**2 Turn on all components connected to this unit via the HDMI connection.**

For details on operations of external components, refer to instruction manuals provided with them.

**3 Check the settings of those components and enable the HDMI control function.**

This unit: Set “Control (SETUP menu → Function Setup → 1 HDMI)” to “On” in the SETUP menu (see page 48).

External components: Refer to their instruction manuals.

**4 Turn off the TV.**

All external components that support the HDMI control function turn off linked to the TV being turned off. If any component does not turn off, turn it off manually.

**5 Turn on the TV.**

Make sure that this unit turns on linked to the TV being turned on. If it does not turn on, turn it on manually.

**6 Set the input of the TV according to the component connected to this unit such as [HDMI].**

**7 If a DVD recorder or Blu-ray recorder that supports the HDMI control function is connected to this unit, turn it on.**

This unit: Make sure that the input source to which the DVD recorder or Blu-ray recorder is connected is selected. If another input source is selected, select the input source manually.

External component: Make sure that you can see images properly on the video monitor.



- You do not need to do step 1 through 7 from the second time.

**8 Perform the following operations with the TV remote control to check the link.**

- Turning on and off
- Adjusting volume
- Switching sound output components

### Notes

- If this unit does not work linked with the TV, turn the TV off and back on or unplug the AC power plug and plug back in. Doing so may solve the problem.
- If the problem still persists, check the following:
  - This unit: Is the HDMI control function set to “On”?  
(see page 48)
  - TV: Is the HDMI control function is enabled?



- If the TV connected to this unit supports the HDMI control function, you only need to connect its audio output jacks to the AV1 jacks of this unit, which are optical digital input jacks, and turn on the video monitor. TV of SCENE is automatically selected when you turn on the TV, and you can enjoy TV sound right away. When connecting the audio output jacks to the AV2-6, AUDIO1-2 or V-AUX jacks, assign those jacks to the TV beforehand (see page 24).

# ADVANCED OPERATION

## Setting the option menu for each input source (OPTION menu)

This unit has the OPTION menu of frequently used menu items for input sources compatible with this unit. The procedure for setting the OPTION menu items is described below.

**1 Select an input source using the **[INPUT]** selector (or **[Input selection keys]**).**

**2 Press **[OPTION]** on the remote control.**

The OPTION menu appears. The displayed OPTION menu items differ depending on the input source. For details, see next section.

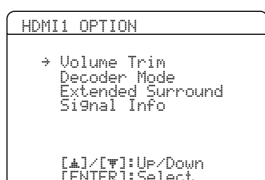

**3 Select the desired menu item using **[Cursor ▲ / ▼]**, and press **[ENTER]**.**

Parameters of the selected menu item are displayed.

**4 Change the setting of the selected menu item (or enable a function) using **[Cursor ▲ / ▼ / < / >]** and **[ENTER]**.**

Details of the selected menu item are displayed.

Parameters you can set differ depending on the menu items.

**5 To close the OPTION menu, press **[OPTION]**.**

You can also use **[RETURN]** to return to the previous screen or close the OPTION menu.



- If **[Cursor]** or other keys do not work after closing the OPTION menu, select the input source again using the **[Input selection keys]**.

### OPTION menu items

The following menu items are provided for each input source.

Input Source	Menu item			
HDMI1-4	Volume Trim	Decoder Mode	Extended Surround	Signal Info
AV1-4	Volume Trim	Decoder Mode	Extended Surround	Signal Info
AV5-6	Volume Trim			
AUDIO1-2	Volume Trim			
V-AUX	Volume Trim			
PHONO	Volume Trim			
iPod (DOCK)	Volume Trim	Shuffle	Repeat	
Bluetooth (DOCK)	Volume Trim	Connect/Disconnect	Pairing	
TUNER	Volume Trim	FM Mode	Auto Preset	Clear Preset
MULTI CH	Volume Trim	Video Out		

Below is a detailed explanation of the menu items in this table.



- The default settings are marked with “\*.”

#### ■ Volume Trim

**Input source:** All

**Adjustable range:** -6.0 dB to 0.0 dB\* to +6.0 dB  
(in 0.5 dB steps)

Reduces any change in volume when switching input sources by correcting volume differences between input sources.

You can set this parameter for each input source.

## ■ Decoder Mode

**Input source:** HDMI1-4, AV1-4

**Choices:** Auto\*/DTS

Selects DTS digital audio signals for reproduction.

**Auto** Automatically selects audio input signals.

**DTS** Selects DTS signals only. Other input signals are not reproduced.

## ■ Extended Surround

**Input source:** HDMI1-4, AV1-4

**Choices:** Auto\*/PLIIX Movie/PLIIX Music/EX/ES/Off

Selects whether to reproduce multi-channel input signals in 6.1- or 7.1-channel when surround back speakers are used.

**Auto** Automatically selects the most suitable decoder according to whether a flag for reproducing surround back channel is present, and reproduces the signals in 6.1- or 7.1-channel.

**PLIIX Movie** Always reproduces signals in 6.1- or 7.1-channel using the PLIIX Movie decoder whether or not surround back channel signals are contained. You can select this parameter when two surround back speakers are connected.

**PLIIX Music** Always reproduces signals in 6.1- or 7.1-channel using the PLIIX Music decoder whether or not surround back channel signals are contained. You can select this parameter when one or two surround back speakers are connected.

**EX/ES** Automatically selects the most suitable decoder for input signals whether or not the flag for reproducing surround back channel is present, and always reproduces signals in 6.1-channel.

**Off** Always reproduces signals in 5.1-channel when 5.1-channel sound is input, whether or not the flag for reproducing surround back channel is present.

## ■ Signal Info

**Input source:** HDMI1-4, AV1-4

Displays information on audio and video signals on the video monitor and front panel display. You can change items to be displayed using **Cursor**  $\Delta$  /  $\nabla$ .

### Signal Info parameters

#### ■ Audio information

Information	Description
Format	Format of digital audio signals.
Channel	The number of input signal channels (front/surround/LFE). For example, if input signal channels are 3 front channels, 2 surrounds and LFE, "3/2/0.1" is displayed. If a channel that cannot be expressed as the above, a total number of channels such as "5.1ch" may be displayed.
Sampling	The sampling frequency of digital input signal.
Bitrate	The bit rate of input signal per second.

#### Notes

- "No Signal" is displayed when no signals are input and "---" is displayed when signals that this unit cannot recognize are input.
- The bit rate may vary during playback.

#### ■ Video information

Information	Description
In	Format and resolution of video input signal.
Out	Format and resolution of video output signal.
Message	Error messages about HDMI signals and HDMI components. See the following for details of the error messages.

#### HDMI error message (appears only when an error has occurred)

HDCP Error	HDCP authentication failed.
Device Over	The number of HDMI components connected is over the limit.
Out of Res.	The connected monitor is not compatible with the video input signal.



## ■ FM Mode

**Input source:** TUNER

**Choices:** Stereo\* Mono

Sets FM broadcasting receiving mode.

**Stereo** Receives in stereo mode.

**Mono** Receives in monaural mode. You can get a better reception in monaural mode.

## ■ Auto Preset

**Input source:** TUNER

Automatically detects radio stations in the FM frequency band and registers them as preset stations (see page 31).

## ■ Clear Preset

**Input source:** TUNER

Clears the preset stations (see page 32).

## ■ Shuffle

**Input source:** iPod (DOCK)

**Choices:** Off\*/Songs/Albums

Changes the shuffle playback style (see page 34).

## ■ Repeat

**Input source:** iPod (DOCK)

**Choices:** Off\*/One/All

Changes the repeat playback style (see page 34).

## ■ Connect/Disconnect

**Input source:** Bluetooth (DOCK)

Switches communication with a Bluetooth component on and off (see page 35).

## ■ Pairing

**Input source:** Bluetooth (DOCK)

Performs pairing of this unit and a Bluetooth component (see page 35).

## ■ Video Out

**Input source:** MULTI CH

**Choices:** AV1 to 6/U-AUX/Off\*

When the multi-channel input is selected, outputs a signal input from another terminal to the video monitor. See "Outputting a video signal input from another input source during reproducing a multi-channel audio signal" on this page.

## Outputting a video signal input from another input source during reproducing a multi-channel audio signal

When "MULTI CH" is selected as the input source, a video signal input from another terminal can be output to the video monitor. For example, even if an audio and video component such as a DVD player that does not support a multi-channel digital audio output, the video signal can be output to the video monitor while reproducing a multi-channel analog audio signal.

- 1 Rotate the **INPUT selector** (or press **MULTI**) to change the input source to "MULTI CH."
- 2 Press **OPTION** on the remote control. The OPTION menu appears.
- 3 Press **Cursor**  $\Delta$  /  $\nabla$  to display "Video Out," and press **ENTER**. The following screen appears.

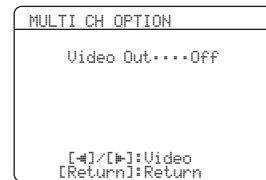

- 4 Press **Cursor**  $\triangleleft$  /  $\triangleright$  to select a video input jack to which a component to be used as a video input source is connected.
  - AV1-2 (COMPONENT VIDEO jacks)
  - AV3-6 (VIDEO jack)
  - V-AUX (VIDEO jack)
  - Off (no video input)
- 5 To end the setting, press **OPTION**.

# Editing surround decoders/sound field programs

## Setting sound field parameters

Although the sound field programs would satisfy you as they are with the default parameters, you can arrange sound effect or decoders suitable for acoustical conditions of sources or rooms by setting the parameters (sound field elements).



- You can protect the sound field against the changes of parameters the sound field parameters when “Memory Guard” of the SETUP menu is set to “On” (see page 50). To change the parameters, set it to “Off.”

**1 Turn on the video monitor connected to this unit.**

**2 Press **[0]SETUP** on the remote control.**  
The SETUP menu appears on the monitor.

**3 Press **[Left]Cursor**  $\Delta$  /  $\nabla$  to select “DSP Parameter” and press **[Enter]**.**

The screen changes as follows.

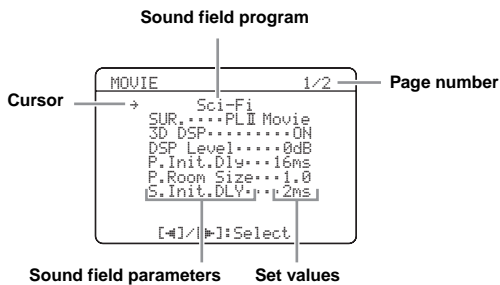

**4 Press **[Left]Cursor**  $\Delta$  /  $\nabla$  to move “→” to the sound field program and press **[Left]Cursor**  $\triangleleft$  /  $\triangleright$  to select the sound field program.**

**5 Press **[Left]Cursor**  $\Delta$  /  $\nabla$  to select the parameter that you want to change, and press **[Left]Cursor**  $\triangleleft$  /  $\triangleright$  to change the parameter.**

An asterisk (\*) appears on the left of the sound field parameter name displayed on the monitor when you change the parameter from its default setting. For details on functions and adjustable ranges of the sound field parameters, see “Sound field parameters” on this page.



- Repeat steps 4 and 5 to change other sound field program parameters.
- A complete list of the parameters of some sound field programs may exceed one page. In this case, press **[Left]Cursor**  $\Delta$  /  $\nabla$  to scroll through pages.

**6 To end the edit, press **[0]SETUP**.**

To initialize the parameters of the selected sound field program, **[Left]Cursor**  $\nabla$  repeatedly to select “Initialize” and then press, **[Left]Cursor**  $\triangleright$ . When the confirmation screen appears on the monitor, press **[Left]Cursor**  $\triangleright$  to confirm the initialization or **[Left]Cursor**  $\triangleleft$  to cancel it.

## Sound field parameters



- The default settings are marked with “\*.”

### CINEMA DSP basic parameters

SUR.

**Choices:** PLIIx Movie\*/Neo:6 Cinema

Selects a surround decoder to be used with a sound field program in the MOVIE category.

PLIIx Movie: Selects the Dolby Pro Logic IIX (Movie) decoder.

Neo:6 Cinema: Selects the Neo:6 (Cinema) decoder.

### Note

- Surround decoders cannot be changed when used with the following MOVIE sound field programs.

- Mono Movie
- Sports
- Action Game
- Roleplaying Game

3D DSP

**Choices:** On\*/Off

When CINEMA DSP 3D is enabled, sets whether to use sound field programs in CINEMA DSP 3D mode.

### Note

- When the presence speakers are not used, the 3D DSP parameters are not displayed.

DSP Level

**Adjustable range:** -6 dB to 0 dB\* to +3 dB

Fine adjusts an effect level (level of the sound field effect to be added). You can adjust the level of the sound field effect while checking sound levels. Adjust “DSP Level” as follows.

- The effect sound is too soft.  
→Increase the effect level.
- There is no difference in effects between the sound field programs.  
→Increase the effect level.
- The sound is dull.
- The sound field effect is added too much.  
→Reduce the effect level.

## Dialog Lift

Choices: 0\* to 5

Adjusts the vertical position of center sound such as dialogues when presence speakers are used. Increasing this parameter raises the position.

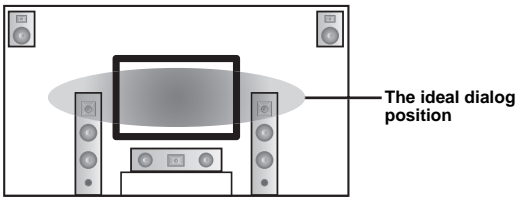

If the dialog seems to come out from a lower position than the video monitor screen, increase this parameter.

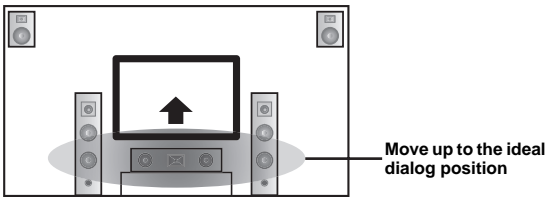

“0” (default) corresponds to the lowest position and “5” to the highest position.

### Notes

- “Dialog Lift” is displayed only when the presence speakers are available.
- You cannot move the dialog position lower than the default setting.

## Sound field parameters for the advanced configurations



- Some sound field programs have parameters for adjusting specific sound fields. The following letters are displayed next to the names of those parameters.
  - P (presence sound field)
  - S (surround sound field)
  - SB (surround back sound field)

### Parameters for adjusting early-reflected sound

Parameter	Adjustable range
Init.Dly	1 to 99ms
P.Init.Dly	1 to 99ms
S.Init.Dly	1 to 49ms
SB Init.Dly	1 to 49ms

Adjust attenuation characteristics of early-reflected sound. You can create a lively sound field (with a high reverberant sound level) as you increase the value, and a dead sound field (with a low reverberant sound level) as you decrease the value. Creating either a lively sound field or a dead sound field in an actual music hall is determined by the acoustic absorption characteristics of reflection surfaces. A dead sound field is created when the attenuation time is short while a lively sound field is created when the attenuation time is long.

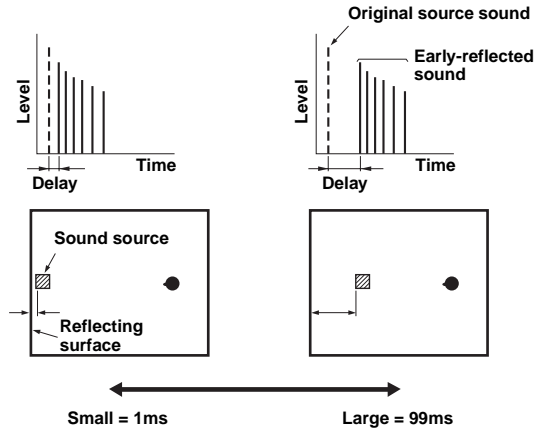

- We recommend that you adjust the size of corresponding sound field when you adjust the delay time.

### Parameters for specifying room size

Parameter	Adjustable range
Room Size	
P.Room Size	0.1 to 2.0
S.Room Size	
SB Room Size	

Produce different senses of sound expansion according to room sizes specified. In a large size room such as a music hall, the duration from when reflected sound is heard until when the next reflected sound is heard is long. Thus, different senses of sound expansion can be created by changing the duration. 1.0 is the original room size. When this parameter is set to 2.0, each side of the room is defined as twice larger than the original room size.

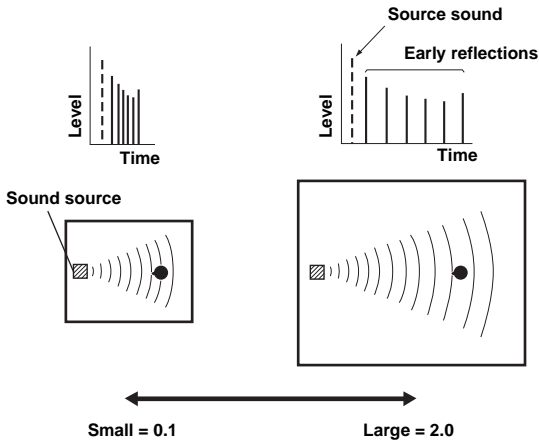

**Parameters for defining attenuation characteristics of early-reflected sound**

Parameter	Adjustable range
Liveness	0 to 10
S.Liveness	0 to 10
SB Liveness	0 to 10

Adjust the attenuation of reflected sound. You can create a lively sound field (with a high reverberant sound level) as you increase the value, and a dead sound field (with a low reverberant sound level) as you decrease the value. Creating either a lively sound field or a dead sound field in an actual music hall is determined by the acoustic absorption characteristics of reflection surfaces. A dead sound field is created when the attenuation time is short while a lively sound field is created when the attenuation time is long.

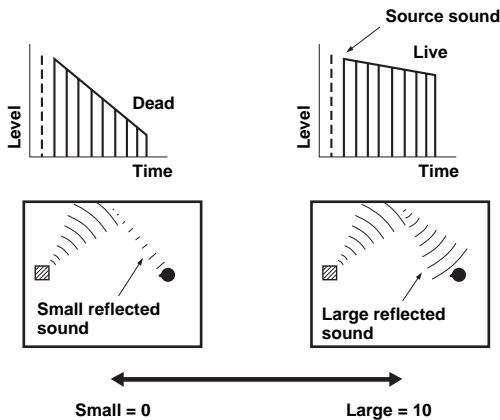

**Parameters for adjusting reverberant sound**

Parameter	Adjustable range
Rev.Time	1.0 to 5.0s
Rev.Delay	0 to 250ms
Rev.Level	0 to 100%

Rev.Time parameter adjusts the attenuation time of the rear reverberant sound based on the time that about 1kHz reverberant sound takes for 60dB of attenuation. Reverberant sound attenuates faster as you decrease the value. Rev.Time adjustment allows you to create a natural reverberant sound, by setting the attenuation time longer for a sound source or room with less echo, or shorter for a sound source or room with more echo.

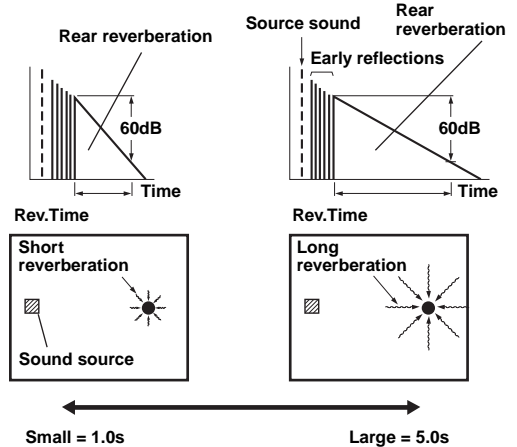

Rev.Delay parameter adjusts the time difference between the beginning of the direct sound and the beginning of the reverberation sound. The larger the value, the later the reverberation sound begins. Increasing the value of Rev.Delay allows you to create a reverberant sound in a wider area for the same Rev.Time.

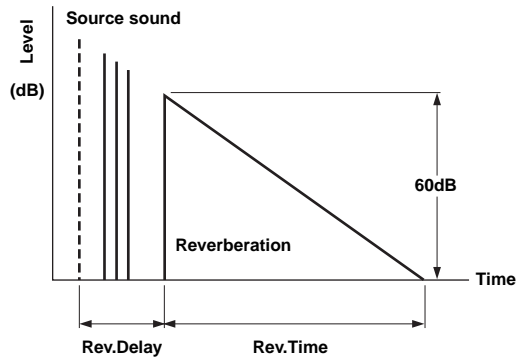

Rev.Level parameter adjusts the reverberation sound level. Increasing the value of Rev.Level makes the reverberation sound level higher, which allows you to create more echo.

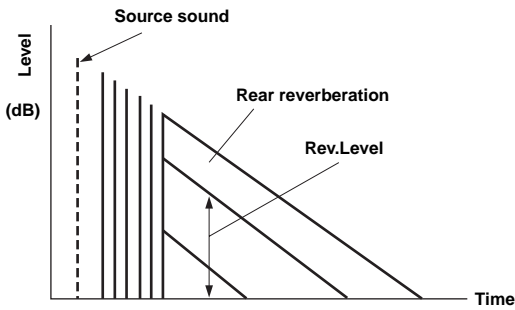

### Parameters only usable in certain sound field programs

#### 2ch Stereo only

##### Direct

**Choices:** Auto\*/Off

Automatically bypasses the DSP circuit and tone control circuit when an analog sound source is selected as the input source. This creates a higher quality sound.

**Auto** Outputs sound by bypassing the DSP circuit and tone control circuit when the “Bass” and “Treble” tone controls are both set to 0 dB.

**Off** Does not bypass the circuits.



• See page 47 for equalizers that can be used with this unit.

#### 7ch Stereo only

CT Level/SL Level/SR Level/  
SB Level/PL Level/PR Level

**Adjustable range:** 0 to 100%

Adjusts the volume of the center (CT), surround L (SL), surround R (SR), surround back (SB), presence L (PL) and presence R (PR) channels in the 7ch Stereo program. The available parameters differ depending on the setting of the speakers.

#### Straight Enhancer/7ch Enhancer only

##### Effect Level

**Choices:** High\*/Low

Adjusts the Compressed Music Enhancer effect level. To reduce the effect, set this parameter to “Low.”

### Decoder parameters

You can customize decoder effects by setting the following parameters. For kinds of decoders, see page 29.

#### When PLIIX Music/PLII Music is selected

##### Panorama

**Choices:** Off\*/On

Adjusts the soundscape of the front sound field. A small value increases the soundscape and a large value narrows it (makes the center more dominant).

##### Dimension

**Adjustable range:** -3 to STD\* to +3

Adjusts the difference in level between the front sound field and the surround sound field. You can adjust the difference in level created by the software being played back to obtain the preferred sound balance. The surround sound gets stronger as you make the value more negative and the front sound gets stronger as you make the value more positive.

##### Center Width

**Adjustable range:** 0 to 3\* to 7

Spreads the center sound toward left and right according to your preference. Set this parameter to 0 for outputting the center sound from the center speaker only, or to 7 for outputting it from the front left/right speaker.

#### When Neo:6 Music is selected

##### C. Image

**Adjustable range:** 0.0 to 0.3\* to 1.0

Adjusts the front left and right channel output relative to the center channel to make the center channel more or less dominant as necessary.

# Changing various settings of this unit (SETUP menu)

You can change various settings of this unit using the SETUP menu. See “Basic operation of the SETUP menu” on the next page, and other respective pages to change the settings.

## ■ List of SETUP menu items

Menu/Submenu	Function	Page
Speaker Setup	Sets items for speakers.	45
1 Auto Setup (YPAO)	Automatically adjusts output characteristics of speakers.	45
2 Manual Setup	Manually adjusts output characteristics of speakers.	45
A)Config	Sets speaker configurations, such as connection status of speaker and a size of the connected speaker (sound reproduction capacity), suitable for the listening environment.	45
B)Level	Separately adjusts volume of each speaker.	47
C)Distance	Adjusts timing at which each speaker outputs sound based on distances between speakers and the listening position.	47
D)Equalizer	Selects an equalizer that adjusts speaker output characteristics.	47
E)Test Tone	Generates test tones.	47
Sound Setup	Sets various items for sound outputs.	47
1 Dynamic Range	Adjusts dynamic ranges of speakers and headphones.	47
2 Lipsync	Adjusts delay in output timing between video signals and audio signals.	48
HDMI Auto	Sets on or off of automatic adjustments for delay between output timing between video signals input from the HDMI jack and audio signals.	48
Auto Delay	Fine adjusts a delay time of HDMI Auto.	48
Manual Delay	Manually fine adjusts the delay of audio and video output.	48
Function Setup	Sets various items for HDMI and display.	48
1 HDMI	Sets various items for input sources.	48
Control	Selects on or off of HDMI control functions.	48
Standby Through	Selects on or off of output of HDMI signals input from the HDMI 1-4 jacks to the HDMI OUT jack when this unit is on standby.	48
Audio Output	Selects this unit or a component connected to this unit via the HDMI OUT jack of this unit for reproducing sound signals input from the HDMI 1-4 jacks.	48
Resolution	Sets resolution of the HDMI output that is converted from analogy video input signals.	48
Aspect	Sets an aspect ratio of images reproduced by HDMI signals converted from analog video input signals.	49
2 Display	Sets items for a monitor or the front panel display.	49
Dimmer	Sets brightness of the front panel display.	49
FL Scroll	Selects the way to display characters on the front panel display.	49
OSD Shift	Adjusts top and bottom positions of the OSD (on-screen display) menus.	49
3 Volume	Sets items for volumes.	49
Adaptive DRC	Adjusts the dynamic range (difference between the maximum volume and the minimum volume) in conjunction with the volume level.	49
Max Volume	Sets the maximum volume level so that the volume will not be accidentally increased.	49
Init. Volume	Sets the volume at the time this unit is turned on.	49
4 Input Rename	Changes input source names to be displayed on a video monitor or the front panel display.	50
5 Zone2	Sets the maximum volume level and initial volume level of Zone2.	50
Max Volume	Sets the maximum volume level so that the volume will not be accidentally increased.	50
Init. Volume	Sets the volume at the time this unit is turned on.	50
DSP Parameter	Sets parameters for the sound field programs.	50
Memory Guard	Protects some settings against accidental alteration.	50

## Basic operation of the SETUP menu

The SETUP menu screen appears on both video display (OSD) and front panel display.

### Video display (OSD)



### Front panel display



In this section, procedures of setting menus displayed on the video monitor are described.

#### 1 Press **SETUP** on the remote control.

The SETUP menu screen appears.

#### 2 Select a menu using **Cursor** $\Delta$ / $\nabla$ , and press **ENTER**.

Items of the selected menu are displayed. For example, the following screen appears when you select "Function Setup."

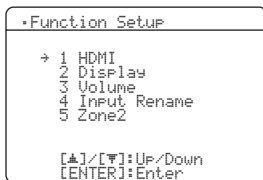

You can return to the previous screen by pressing **RETURN**.

#### 3 To display submenus, select a menu that you want to set using **Cursor** $\Delta$ / $\nabla$ , and press **ENTER**.

For example, the following screen appears when you select "2 Display."

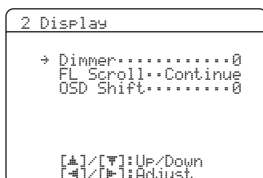

#### 4 Select an item using **Cursor** $\Delta$ / $\nabla$ , and change the setting of the item using **Cursor** $\leftarrow$ / $\rightarrow$ .

Some items in the Manual Setup menu of Speaker Setup take up a full screen. To display other items in the Manual Setup menu, press **Cursor**  $\Delta$  /  $\nabla$ .

### Example: A)Config

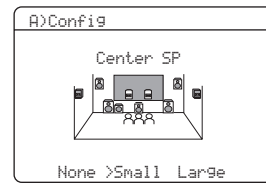

You can change other items by repeating step 4.

#### 5 To finish setting, press **SETUP**.



If **Cursor** or other keys do not work after exiting the SETUP menu, select the input source again using **Input selection keys**.

## Speaker Setup

You can set various items for speakers. Two kinds of adjustments are available. One is "1 Auto Setup (YPAO)" for automatic adjustment and another is "2 Manual Setup" for manual adjustment.



The default settings are marked with "\*".

### 1 Auto Setup

Automatically adjusts output characteristics of speakers to obtain optimum balance for the output sound based on positions and performances of the speakers and acoustic characteristics of the room, which are automatically measured. For details on operations, see page 21.

### 2 Manual Setup

Adjusts output characteristics of speakers based on manually set parameters.

After Auto Setup (YPAO) is performed, you can check automatically adjusted parameters in the Manual Setup menu. Fine adjust the parameters for your preference if necessary.

#### A)Config

Sets speaker configurations, such as connection status of speaker and a size of the connected speaker (sound reproduction capacity), suitable for the listening environment.



The speaker configuration includes items for defining a speaker size: Large or Small. Large and Small refer to speakers with woofer diameters 16 cm or larger and smaller than 16 cm, respectively.

#### Extra SP Assign

**Choices:** Zone2\*/Presence/None

Selects the application for EXTRA SP jacks.

**Zone2** Assigns the EXTRA SP jacks for the speakers in the second zone.

**Presence** Assigns the EXTRA SP jacks for the Presence speaker.

**None** Disables the EXTRA SP jacks.

#### Note

When setting "Extra SP Assign" to "Zone2" or "Presence," the surround back channel signals for main output is separately output from other channels.

## LFE/Bass Out

**Choices:** SWFR/Front/Both\*

Selects speaker(s) for outputting low-frequency components of the LFE (low-frequency effect sound) channel or other channels. The output status is as follows.

LFE channel signals

Parameter	Subwoofer	Front speakers	Other speakers
Both	Output	Not output	Not output
SWFR	Output	Not output	Not output
Front	Not output	Output	Not output

Low-frequency components of other channel signals

Parameter	Subwoofer	Front speakers	Other speakers
Both	[1]	[2]	[3]
SWFR	[4]	[3]	[3]
Front	Not output	[1]	[3]

- [1] Outputs low-frequency components of the front left and right channels and the channel of speaker, the size of which is set to "Small."
- [2] Outputs low-frequency components of the front left and right channels.
- [3] Outputs low frequency components when the sizes of speakers are set to "Large."
- [4] Outputs low-frequency components of the channel of speaker, the size of which is set to "Small."

## Front SP

**Choices:** Small/Large\*

Sets the sizes of front left and right speakers.

- Small** Select this when small speakers are connected. Low-frequency components of the front left and right channels are output from a subwoofer.
- Large** Select this when large speakers are connected.

### Note

- When "LFE/Bass Out" is set to "Front," you can only select "Large." If "LFE/Bass Out" is changed to "Front," this parameter automatically switches to "Large" even when it is set to "Small."

## Center SP

**Choices:** None/Small\*/Large

Sets the size of center speaker.

- None** Select this when no center speaker is connected. Center channel signals are spread to front left and right speakers.
- Small** Select this when a small center speaker is connected. Low-frequency components of center channel are output from a subwoofer. If a subwoofer is not connected they are output from front speakers.
- Large** Select this when a large center speaker is connected.

## Sur. L/R SP

**Choices:** None/Small\*/Large

Sets sizes of left and right surround speakers.

- None** Select this when no surround speakers are connected. Surround channel signals are spread to front left and right speakers. "Sur.B L/R SP" automatically switches to "None" when this is selected.
- Small** Select this when small surround speakers are connected. Low-frequency components of surround channels are output from a subwoofer. If a subwoofer is not connected they are output from front speakers.
- Large** Select this when large surround speakers are connected.



- When "None" is selected, the sound field programs automatically enter the Virtual CINEMA DSP mode.

## Sur. B L/R SP

**Choices:** None/SMLx1/SMLx2\*/LRGx1/LRGx2

Sets sizes of left and right surround back speakers.

- None** Select this when no surround back speaker are connected. Surround back channel signals are output from the surround L/R speakers and subwoofer. If the subwoofer is disabled, they are output from the surround L/R speakers and front speakers.
- SMLx1** Select this when one small surround back speaker is connected.
- SMLx2** Select this when two small surround back speakers are connected.
- LRGx1** Select this when one large surround back speaker is connected.
- LRGx2** Select this when two large surround back speakers are connected.

### Note

- When "None" is selected, "PLIIX Movie," "PLIIX Music," and "PLIIX Game" cannot be selected.



### Crossover Freq.

**Choices:** 40Hz/60Hz/80Hz\*/90Hz/100Hz/110Hz/120Hz/160Hz/200Hz

Sets the lower limit of the low frequency component output from a speaker with a size set to "Small (SMLx1/SMLx2)." Sound with a frequency below that limit is output from a subwoofer or front speakers.



- If your subwoofer has a volume control or a crossover frequency control, set the volume to half or the crossover frequency at the maximum.

### Subwoofer Phase

**Choices:** Normal\*/Reverse

Sets the phase of your subwoofer if bass sounds are lacking or unclear.

**Normal** Select this not to change the phase of your subwoofer.

**Reverse** Select this to reverse the phase of your subwoofer.

### B)Level

**Adjustable range:** -10.0dB to +10.0dB (0.5 dB steps)

**Defaults:** "FR.L/FR.R/SWFR/PR.L/PR.R" 0dB  
"CNTR/SUR.L/SUR.R/SBL/SBR" -1.0dB

Separately adjusts volume of each speaker so that the sounds from speakers are at the same volume at the listening position. Items to be displayed vary depending on the number of speakers connected.



- When only one surround back speaker is connected, "SB" appears instead of "SBL" and "SBR."
- You can adjust the volume listening to test tones when you set "E)Test Tone" to "On" (see page 47).
- If your subwoofer has a volume control or a crossover frequency control, set the volume to half or the crossover frequency at the maximum.

### C)Distance

Adjusts timing at which each speaker outputs sound so that sounds from speakers reach the listening position at the same time. Set the unit (Unit) first and then the distance of each speaker.

#### Unit

**Choices:** meters (m)\*/feet (ft)

**meters (m)** Displays the speaker distance in meters.

**feet (ft)** Displays the speaker distance in feet.

Front L/Front R/Center/Sur. L/  
Sur. R/Sur. B L/Sur. B R/SWFR/  
PRNS L/PRNS R

**Adjustable range:** 0.30m to 24.00m (1.0ft to 80.0ft)

**Defaults:** 3.00m (10.0ft) "Front L/Front R/  
SWFR/PRNS L/PRNS R"  
2.60m (8.5ft) "Center"  
2.40m (8.0ft) "Sur. L/Sur. R/  
Sur. B L/Sur. B R/PRNS L/PRNS R"



- Different items are displayed depending on settings of "A)Config" (see page 45).
- When only one surround back speaker is connected, "Sur.B" appears instead of "Sur.B L" and "Sur.B R."

### D)Equalizer

Adjusts sound quality and tone using a parametric graphic equalizer.

#### EQ Type Select

**Choices:** Auto PEQ/GEQ\*/Off

Selects an equalizer type.

**Auto PEQ** Uses a parametric equalizer selected in "1 Auto Setup." Characteristics of the currently used parametric equalizer (see page 21) are displayed below "Auto PEQ."

If Auto Setup is not executed, this parameter is not displayed.

**GEQ** Adjusts tone using a graphic equalizer. To

display the adjustment menu, press

**ENTER.**

**Off** Not use a graphic equalizer.

#### GEQ

**Choices:** 63Hz/160Hz/400Hz/1kHz/2.5kHz/  
6.3kHz/16kHz

**Adjustable range:** -6.0dB to 0dB\* to +6.0dB (0.5 dB steps)

Adjusts sound quality of each speaker using a graphic equalizer. The graphic equalizer of this unit can adjust signal levels in 7 frequency ranges.

To adjust the signal level within each range, select the desired speaker with **Cursor** </> while "→" is displayed next to "Channel," then the desired frequency band with **Cursor** Δ / ▽, and adjust the signal level with **Cursor** </>.

### E)Test Tone

**Choices:** Off\*/On

Switches test tones on and off. To generate test tones select "On" using **Cursor** </>. When "On" is selected, you can adjust the settings of "2 Manual Setup" while listening to a test tone.

**Off** Does not generate test tones.

**On** Generates test tones.

## Sound Setup

You can set various items for sound outputs.



- The default settings are marked with "\*".

### 1 Dynamic Range

**Choices:** Min/Auto/STD/Max\*

Selects the dynamic range adjustment method for reproducing bitstream signals.

**Min/Auto** (Min) Sets the dynamic range suitable for low volume or a quiet environment, such as at night, for bitstream signals except for Dolby TrueHD signals.

(Auto) Adjusts the dynamic range for Dolby TrueHD signals based on input signal information.

**STD** Sets the standard dynamic range recommended for regular home use.

**Max** Outputs sound without adjusting the dynamic range of the input signals.

## ■ 2 Lipsync

Adjusts delay between video output and audio output.

### HDMI Auto

**Choices:** Off\*/On

Automatically adjusts output timing of audio and video signals when a monitor that supports an automatic lip-sync function is connected to this unit.

- Off** Select this when the connected monitor does not support the automatic lip-sync function or that function is not to be used. Set the correction time in "Manual Delay."
- On** Select this when the connected monitor supports the automatic lip-sync function. Fine adjust the correction time in "Auto Delay."

### Auto Delay

**Adjustable range:** 0\* to 240ms (1 ms steps)

Fine adjusts the correction time when "HDMI Auto" is set to "On." The actual correction time is displayed under in "Auto Delay" field and an offset time set by the user in "offset" field.

### Manual Delay

**Adjustable range:** 0\* to 240ms (1 ms steps)

Manually fine adjusts the correction time. Select this when the connected monitor does not support the automatic lip-sync function or you set "HDMI Auto" to "Off."

## Function Setup

You can set various items for HDMI and display.



- The default settings are marked with "\*".

### 1 HDMI

You can set items for HDMI.

#### ■ Control

**Choices:** On/Off\*

Selects on or off of HDMI control functions when a component that supports the HDMI control functions is connected with this unit.

When this is set to "On," signals input from the HDMI 1-4 jacks are output to a monitor component even when this unit is on standby.

- On** Enables the HDMI control function.
- Off** Disables the HDMI control function.

#### ■ Standby Through

**Choices:** On/Off\*

Selects on or off of output of HDMI signals input from the HDMI 1-4 jacks to the HDMI OUT jack when this unit is on standby. When this parameter is set to "On" signals input from the HDMI 1-4 jacks can be output to a monitor component.

This item is not displayed when "Control" is set to "On."

- On** Outputs the HDMI signals to the HDMI OUT jack.
- Off** Does not output the HDMI signals to the HDMI OUT jack.



- To enable pass-through output, any one of the input sources connected to the HDMI 1-4 jacks must be selected before switching to standby.
- During pass-through output, the HDMI THROUGH indicator on the front panel display lights up. While the indicator lights up, it consumes 1 to 3W of power depending on a condition of an HDMI signal passing through this unit.

#### ■ Audio Output

**Choices:** AMP\*/TV/AMP+TV

Selects this unit or a component connected to this unit via the HDMI OUT jack of this unit for reproducing sound signals input from the HDMI 1-4 jacks.

This item is not displayed when "Control" is set to "On."

- AMP** Outputs HDMI sound signals from the speakers connected to this unit.
- TV** Outputs HDMI sound signals from the speakers of a TV connected to this unit. Sound output from the speakers connected to this unit is muted.
- AMP+TV** Outputs HDMI sound signals from the speakers connected to this unit and the speakers of a TV connected to this unit.

#### Note

- When "TV" or "Amp+TV" is selected, signal formats of audio and video signals output from this unit to the monitor vary depending on specifications of the monitor.

#### ■ Resolution

**Choices:** Through\*/480P or 576P/720P/1080i/1080P

Upscales the resolution of HDMI output that is converted from analog video input signals and output from the HDMI OUT jack.

#### Notes

- Resolution of the HDMI output converted from 720p or 1080i video signals cannot be upscaled.
- When a video monitor is connected to this unit via the HDMI jack, this unit automatically detects a resolution that the monitor supports. An asterisk (\*) appears on the left of the detected resolution.
- If this unit cannot detect the resolution that the monitor supports, set "MON.CHK" in the ADVANCED SETUP menu to "SKIP" (see page 55) and try it again.

### ■ Aspect

**Choices:** Thruh\*/16:9/Smart

Sets a horizontal to vertical ratio (aspect ratio) of images reproduced by HDMI signals output from the HDMI OUT jack when the HDMI signals are converted from analog video input signals by a video conversion function.

- Thruh Outputs the video signals without changing the aspect ratio.
- 16:9 Outputs the video signals that displays 4:3 images on a 16:9 monitor with black bands on the right and left sides of the monitor screen.
- Smart Outputs the video signals that displays 4:3 images on a 16:9 monitor by stretching right and left of images to fit on the monitor screen.

#### Notes

- You cannot change the aspect ratio of the screen when "Resolution" is set to "Through."
- The setting is not effective for inputs with the aspect ratio other than 4:3.
- You cannot obtain an effect of the aspect ratio when video signals are input from the HDMI 1-4 jacks or 720p, 1080i or 1080p signals are input.

## 2 Display

You can change some parameters for a monitor or the front panel display.

### ■ Dimmer

**Adjustable range:** -4 to 0\*

Sets brightness of the front panel display. As the value is lowered, the brightness of the front panel display is darkened.

#### Note

- The brightness of display does not become bright in Pure Direct mode even if the value is increased.

### ■ FL Scroll

**Choices:** Continue\*/Once

Selects the way to scroll the screen when a total number of characters exceed a display area of the front panel display.

- Continue Repeatedly displays all characters by scrolling.
- Once Displays all characters by scrolling once, halts scrolling, and then displays first 14 characters.

### ■ OSD Shift

**Adjustable range:** -5 to 0\* to +5

Adjusts top and bottom positions of the OSD (on-screen display) menus. To move up the screen, set this value larger. To move down the screen, set it smaller.

## 3 Volume

You can change some parameters for volumes.

### ■ Adaptive DRC

**Choices:** Auto/Off\*

Adjusts the dynamic range in conjunction with the volume level. This function is useful when you are listening at lower volumes or at night. When this function is enabled, the dynamic range is adjusted as follows.

If the volume setting is low:

the dynamic range is narrow

If the volume setting is high:

the dynamic range is wide

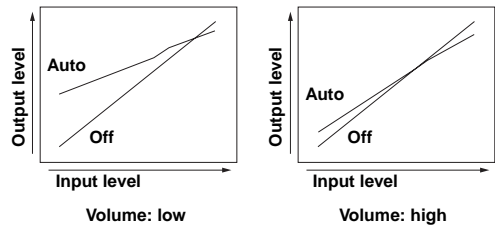

- Auto Adjusts the dynamic range automatically.
- Off Does not adjust the dynamic range automatically.



- The "Adaptive DRC" setting is effective for headphones.

### ■ Max Volume

**Adjustable range:** -30.0dB to +15.0dB/+16.5dB\* (5.0 dB steps)

Sets the maximum volume level so that the volume will not be accidentally increased. For example, you can adjust the volume between -80.0 dB and -5.0 dB or mute when you set this parameter to "-5.0dB." The volume increases to the maximum level when this parameter is set to +16.5 dB (default).

### ■ Init. Volume

**Choices:** Off\*/Mute/-80.0dB to +16.5dB (0.5 dB steps)

Sets the volume at the time this unit is turned on. When this parameter is set to "Off," the volume is set to a level that last time this unit is set to standby.

#### Note

- If the setting of "Max Volume" is lower than the setting of "Init. Volume," the setting of "Max Volume" becomes effective. For example, when you set "Max Volume" to "-30.0dB" and "Init. Volume" to "0.0dB," the volume is automatically set to "-30.0dB" at the next time this unit is turned on.

## 4 Input Rename

You can change input source names to be displayed on the front panel display.

You can select an input source that you want to change the name to be displayed using **[F1]Cursor**.

### Selecting a name to be displayed from templates

Select an input source that you want to change the name, and select a name from the following templates using **[F1]Cursor**.

- Blu-ray	- Satellite
- DVD	- VCR
- SetTopBox	- Tape
- Game	- MD
- TV	- PC
- DVR	- iPod
- CD	- HD DVD
- CD-R	- "blank"



- If you change the display name of an input source to your original one and select the input source, the current input source name and the template name are displayed. This is convenient if you want to cancel name change operation.

### Entering an original name

Select an input source that you want to name, and press **[F1]ENTER**. You can enter up to 9 characters by selecting one character at a time with the following keys according to the following operation.

<b>[F1]Cursor</b> < / >	For selecting characters that you want to change
<b>[F1]Cursor</b> Δ / ▽	For selecting characters to be entered
<b>[F1]ENTER</b>	For entering the selected characters

The following characters are available for input.  
A to Z, 0 to 9, a to z, symbols (#, \*, -, +, etc.) and space

## 5 Zone2

You can set the maximum volume level and initial volume level of Zone2.



- This item is displayed only when "Extra SP Assign" is set to "Zone2."

### ■ Max Volume

**Adjustable range:** -30.0dB to +15.0dB / +16.5dB\*  
(5.0 dB steps)

Sets the maximum volume level of Zone2 so that the volume will not be accidentally increased. For example, you can adjust the volume between -80.0 dB and -5.0 dB or mute when you set this parameter to "-5.0dB."

### ■ Init. Volume

**Choices:** Off\*/Mute/-80.0dB to +16.5dB (0.5 dB steps)

Sets the volume level of Zone2 when the power of Zone2 unit is turned on.

### Note

- If the setting of "Max Volume" is lower than the setting of "Init. Volume," the setting of "Max Volume" becomes effective. For example, when you set "Max Volume" to "-30.0dB" and "Init. Volume" to "0.0dB," the volume is automatically set to "-30.0dB" at the next time this unit is turned on.

## DSP Parameter

You can change some parameters for the sound field programs. For details, see page 40.

## Memory Guard



- The default settings are marked with "\*".

**Choices:** Off\*/On

Protects settings of SETUP menu against accidental alteration.

Off	Does not protect settings.
On	Protects the settings of the SETUP menu (except for the Memory Guard setting).

### Note

- When this parameter is switched to "On," "G" appears while the SETUP menu is displayed on the video monitor.

# Using multi-zone configuration

This unit allows you to configure a multi-zone audio system. The Zone2 feature allows you to set this unit to reproduce separate input sources in the main zone and the second zone (Zone2). You can control this unit from the second zone using the supplied remote control.

Only analog signal can be sent to Zone2. If you want to output sound from Zone2, connect an external component to AV5-6 or AUDIO1-2 by analog connection. For example, if you want to output sound from an HDMI DVD player in Zone2, you must connect the component to this unit by both HDMI and analog connections.

## Connecting Zone2

You need the following additional equipment to use the multi-zone functions of this unit:

- An infrared signal receiver in the second zone.
- An infrared signal emitter in the main zone. This emitter transmits infrared signals from the remote control to a CD player or a DVD player, etc. in the main zone via the infrared signal receiver in the second zone.
- An amplifier and speakers in the second zone.



- Since there are many possible ways to connect and use this unit in a multi-zone configuration, we recommend that you consult with your nearest authorized Yamaha dealer or service center about the Zone2 connections that best meet your requirements.
- Some Yamaha models can be directly connected to the REMOTE jacks of this unit. These models may not require an infrared signal emitter. Up to 6 Yamaha components can be connected as shown below.

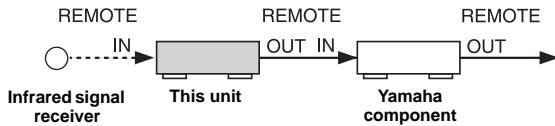

## Using the external amplifier

You can connect the amplifier/receiver in the second zone and other components to this unit as follows.

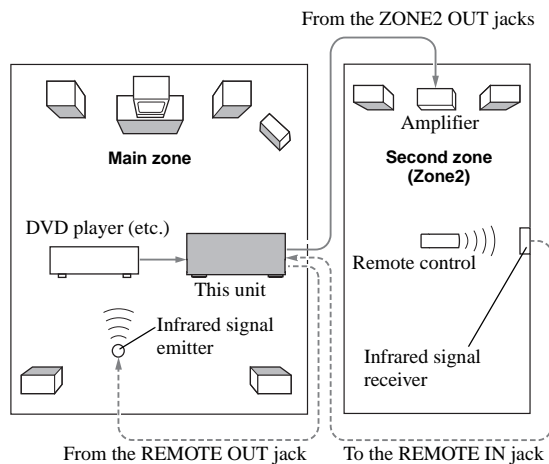

## Note

- To avoid unexpected noise, DO NOT USE the Zone2 feature with CDs encoded in DTS.

## Using the internal amplifier of this unit

### Important safety notice

The EXTRA SP jacks of this unit should not be connected to a Passive Loudspeaker Selector Box or more than one loudspeaker per channel. Connection to a Passive Loudspeaker Selector Box or multiple speakers per channel could create an abnormally low impedance load resulting in amplifier damage. See this owner's manual for correct usage. Compliance with minimum speaker impedance information for all channels must be maintained at all times. This information is found on the back panel of this unit.

Connect the speakers in the second zone to the EXTRA SP jacks and then set the "Extra SP Assign" to "Zone2" (see page 45).

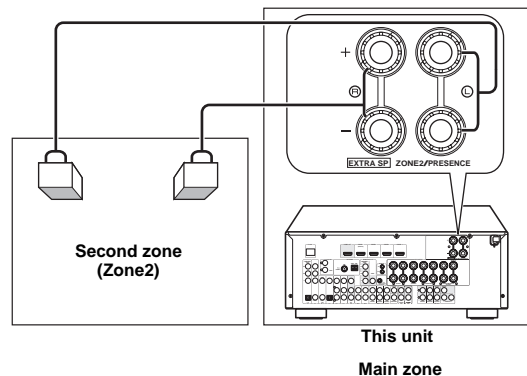

- You can use the speakers connected to the EXTRA SP jacks as the front speaker system of another zone. Set "Extra SP Assign" to "Zone2" (see page 45).
- When you use the internal amplifiers for the Zone2 speakers, you can adjust the volume level and set the initial volume and maximum volume of the Zone2 speakers (see page 50).

## Controlling Zone2

You can select and control Zone2 by using the control keys on the front panel or on the remote control. The available operations are as follows:

- Selecting the input source (AV5-6, AUDIO1-2, V-AUX) of Zone2.
- Adjusting the volume of Zone2 (when a Zone2 speaker is connected to the EXTRA SP jack).
- Tuning into FM or AM when “TUNER” is selected as the input source of Zone2 (see page 31).
- Playing back music stored on your iPod stationed in a Yamaha iPod universal dock (such as YDS-11 sold separately) connected to the DOCK jack.
- You can play back music stored on a Bluetooth component via a Bluetooth wireless audio receiver (sold separately) connected to the DOCK jack (see page 35).

### Note

- You must complete each step while the ZONE2 indicator is flashing on the front panel display. Otherwise, the Zone2 mode is automatically canceled and this unit returns to the normal operation mode. In this case, repeat the Zone2 selection procedure.

## Controlling Zone2 with the front panel

### ■ Turning on Zone2

Press **Ⓢ** **ZONE2 ON/OFF** to turn on Zone2.

### ■ Activating the Zone2 operation mode

Press **Ⓢ** **ZONE2 CONTROL** to control Zone2.

The ZONE2 indicator flashes on the front panel display for approximately 10 seconds.

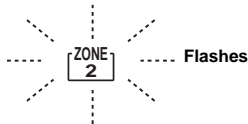

### ■ Operating Zone2

Rotate the **Ⓡ** **INPUT selector** to select the desired input source while the ZONE2 indicator on the front panel display is flashing.

- When AV5-6, AUDIO1-2 or V-AUX is selected, you can listening to the input source in Zone2.
- Select “TUNER” as the input source to use the TUNER features in Zone2. For details about the TUNER operations, see “FM/AM tuning” on page 31.
- Select “DOCK” as the input source to use iPod features in Zone2. For details about the iPod operations, see “Using iPod” on page 33.
- Select “DOCK” as the input source to use Bluetooth component features in Zone2. For details about the Bluetooth component operations, see “Using Bluetooth components” on page 35.

### ■ Setting Zone2 to standby

Press **Ⓢ** **ZONE2 ON/OFF** to set Zone2 to standby.

## Controlling Zone2 with the remote control

### ■ Turning on Zone2

Set **Ⓢ** **MAIN/ZONE2** to the ZONE2 position, and press **Ⓢ** **POWER**.

### ■ Operating Zone2

Set **Ⓢ** **MAIN/ZONE2** to the ZONE2 position, and press one of the input selection keys to select the desired input source of Zone2.

### Note

- **Ⓢ** **MUTE** and **Ⓢ** **VOLUME +/-** are available to control Zone2 with same procedure as mentioned above.

### ■ Setting Zone2 to standby

Set **Ⓢ** **MAIN/ZONE2** to the ZONE2 position, and press **Ⓢ** **POWER**, then set ZONE2 to standby.

# Controlling other components with the remote control

You can control external components for a selected input source with the remote control. The keys available for controlling external components are as follows:

## 4 SOURCE POWER

Turns on and off an external component.

## 11 Cursor, ENTER, RETURN

Operates the menus of external components.

## 20 DISPLAY

Switches between the screens of external components.

## 12 External component operation keys

Function as a recording or playback key of an external component, or a menu display key.

## 13 Numeric keys

Function as numeric keys of an external component.

## 14 TV control keys

**INPUT** Switches video inputs of TV

**MUTE** Mute audio of TV

**TV VOL +/-** Controls the volume of TV

**TV CH +/-** Switches channels of TV

**POWER** Turns on and off TV



- You need to set the remote control code first to control external components.
- The remote control keys for controlling external components are available only when the external components have corresponding control keys.

The following remote control codes are assigned to input sources as factory default settings. For a complete list of available remote control codes, refer to “List of remote control codes” at the end of this manual.

### ■ Default remote control code settings

Input source	Category	Manufacturer	Default code
[HDMI1]	Blu-ray Disc	Yamaha	2018
[HDMI2]	—	—	—
[HDMI3]	—	—	—
[HDMI4]	—	—	—
[AV1]	—	—	—
[AV2]	—	—	—
[AV3]	CD	Yamaha	5013
[AV4]	—	—	—
[AV5]	—	—	—
[AV6]	—	—	—
[AUDIO1]	—	—	—
[AUDIO2]	—	—	—
[V-AUX]	—	—	—
[PHONO]	—	—	—
[A]	—	—	—

Input source	Category	Manufacturer	Default code
[DOCK]	DOCK	Yamaha	5011
[TUNER]	Tuner	Yamaha	5007
[MULTI CH]	—	—	—

“—” indicates no assignment



- An external component that is controlled by the remote control can be automatically selected according to the [9] SCENE key selection (see page 25).

## Setting remote control codes

You can control other components by setting the appropriate remote control codes. For a complete list of available remote control codes, refer to “List of remote control codes” at the end of this manual.



- Each of the steps described in this section should be performed within one minute. Setting operation is automatically canceled when one minute has passed since the last step. If the operation is cancelled, start again from the beginning.

- Press [5] **CODE SET** on the remote control using a pointed object such as the tip of a ballpoint pen.  
[3] **TRANSMIT** on the remote control blinks twice.
- Press [5] **Input selection keys** corresponding to the input source whose remote control code you want to register.

- Enter a remote control code using [13] **Numeric keys**.

Once the remote control code is registered, [3] **TRANSMIT** on the remote control blinks twice. If it fails, [3] **TRANSMIT** blinks six times. Repeat from step 1.

## Resetting all remote control codes

You can clear all the remote control codes previously set, and reset all of them to the initial factory settings.



- Each of the steps described in this section should be performed within one minute. Setting operation is automatically canceled when one minute has passed since the last step. If the operation is cancelled, start again from the beginning.

- 
- 1 Press **[15]**CODE SET on the remote control using a pointed object such as a tip of a ballpoint pen.**  
**[3]**TRANSMIT on the remote control blinks twice.

---

  - 2 Press **[10]**SETUP on the remote control.**

---

  - 3 Enter “9981” using **[13]**Numeric keys.**  
Once the initialization is complete, **[3]**TRANSMIT on the remote control blinks twice. If it fails, **[3]**TRANSMIT blinks six times. Repeat from step 1.



# Advanced setup

The advanced setup includes more parameters for basic operation of this unit such as turning a bi-amp connection on and off and initializing user settings. This section describes what those parameters are and how to change them.

## 1 Set this unit to standby.

## 2 Press **Ⓐ** MAIN ZONE ON/OFF while pressing and holding **Ⓟ** STRAIGHT on the front panel.

The ADVANCED SETUP menu appears on the front panel display.



ADVANCED SETUP

## 3 Rotate the **Ⓞ** PROGRAM selector to select the parameter you want to change.



- Set values are placed in XXX of the following parameters on an actual display screen.
- The default setting are marked with “\*.”

SP IMP. -XXX

**Choices:** 6ΩMIN/8ΩMIN\*

Selects output impedance of this unit according to connected speakers. When you connect 4-ohm speakers to the FRONT jacks of the SPEAKERS terminals, set “SP IMP.” to “6ΩMIN.”

REMOTE ID -XXX

**Choices:** ID1\*/ID2

Selects a remote control ID for this unit. When using multiple Yamaha AV receivers, you can operate them with a single remote control by setting them to have the same remote control ID. By setting the receivers to have different remote control IDs, you can operate them with their respective remote controls.

BI AMP - XXX

**Choices:** ON/OFF\*

Switches on and off of bi-amp connection of main speakers. For bi-amp connection, see page 13.

SCENE IR -XXX

**Choices:** ON\*/OFF

Selects whether or not to transmit the SCENE control signals to an external component connected to the REMOTE jacks on this unit when BD/DVD or CD SCENE function is selected. If “ON” is selected and a playback component that supports the SCENE link playback, such as a Yamaha DVD player, is connected to the REMOTE OUT jack of this unit, remote connection automatically starts playback when a different SCENE key is selected.

MON. CHK - XXXX

**Choices:** YES\*/SKIP

Adds upscaling limitation on output signals to a video monitor connected to this unit via the HDMI OUT jack.

INIT-XXXXXXXXXX

**Choices:** DSP PARAM/VIDEO/ALL/CANCEL\*

Initializes various settings stored in this unit. You can select an initialization method from the following.

DSP PARAM Resets all parameters of sound field programs.

VIDEO Resets video conversion settings (resolution/aspect) in the SETUP menu and the OSD menus display position.

ALL Resets this unit to initial factory settings.

CANCEL Initialization.

## 4 Press **Ⓟ** STRAIGHT a few times to select the value you want to change.

The value selected here becomes effective when this unit is turned on the next time. You can change multiple settings by repeating steps 3 and 4.

## 5 Press **Ⓐ** MAIN ZONE ON/OFF, turns off this system, and press **Ⓐ** MAIN ZONE ON/OFF again.

The value set in step 4 becomes effective, and this unit turns on. When you select initialization in step 3, the initialization is performed.

## Setting a remote control ID

Two IDs are provided for the remote control of this unit. If another Yamaha amplifier is in the same room, setting a different remote control ID to this unit prevents unwanted operation of the other amplifier.

ID1 is set for both remote control and amplifier by default.

When you change the remote control ID, display “ADVANCED SETUP” (see the previous section) and change the ID for the amplifier too.



- Each of the steps described in this section should be performed within one minute. Setting operation is automatically canceled when one minute has passed since the last step. If the operation is cancelled, start again from the beginning.

**1 Press [15]CODE SET on the remote control using a pointed object such as the tip of a ballpoint pen.**

[3]TRANSMIT blinks twice.

**2 Press [10]SETUP on the remote control.**

**3 Enter the desired remote control ID code.**

To switch to ID1:

Enter “5019” using [13]Numeric keys.

To switch to ID2:

Enter “5020” using [13]Numeric keys.

Once the remote control code is registered,

[3]TRANSMIT blinks twice.

If it fails, [3]TRANSMIT blinks six times. Repeat from step 1.



- Initializing the remote control code (see page 54) returns it to ID1.

# APPENDIX

## Troubleshooting

Refer to the table below when this unit does not function properly. If the problem you are experiencing is not listed below or if the instruction below does not help, turn off this unit, disconnect the power cable, and contact the nearest authorized Yamaha dealer or service center.

### General

Problem	Cause	Remedy	See page
<b>This unit turns off soon after being turned on, or does not turn on after <b>Ⓐ</b> MAIN ZONE ON/OFF (or <b>Ⓘ</b> POWER) is pressed.</b>	The power cable is not connected or the plug is not completely inserted.	Connect the power cable properly to an AC wall outlet.	—
	The speaker impedance setting is incorrect.	Set the speaker impedance to match your speakers.	55
	(When this unit is turned back on and “CHECK SP WIRES!” is displayed.) The protection circuitry has been activated because this unit was turned on while a speaker cable was shorted.	Make sure that all speaker cables between this unit and speakers are connected properly.	13
<b>This unit cannot be turned off or does not work properly.</b>	The internal microcomputer is frozen due to an external electric shock (such as lightning or excessive static electricity) or by a drop in power supply voltage.	Disconnect the power cable from the AC wall outlet, wait about 30 seconds and then plug it in again.	—
<b>This unit suddenly enters the standby mode.</b>	The internal temperature becomes too high and the overheat protection circuitry has been activated.	Wait about 1 hour for this unit to cool down and then turn it back on.	—
<b>Sound/images suddenly go off.</b>	The protection circuitry has been activated because of a short circuit, etc.	Check that the speaker impedance setting is correct.	55
		Check that the speaker wires are not touching each other and then turn this unit back on.	—
	The sleep timer has turned off this unit.	Turn on this unit, and play the source again.	—
<b>“CHECK SP WIRES!” appears on the front panel display.</b>	Speaker cables are short-circuited.	Make sure all speaker cables are connected correctly.	13
<b>“Memory Guard!” is displayed on the front panel display and the setting cannot be changed.</b>	“Memory Guard” in the SETUP menu is set to “On.”	Set “Memory Guard” to “Off.”	50
<b>The picture is disturbed.</b>	The video software is copy-protected.		

<b>Problem</b>	<b>Cause</b>	<b>Remedy</b>	<b>See page</b>
<b>No sound.</b>	Incorrect input or output cable connections.	Connect the cables properly. If the problem persists, the cables may be defective.	15-19
	Speaker connections are not secure.	Secure the connections.	11
	The HDMI components connected to this unit do not support the HDCP copy protection standards.	Connect HDMI components that support the HDCP copy protection standards.	69
	The HDMI audio output parameter in the SETUP menu (Function Setup → 1 HDMI → Audio Output) is set to "TV."	Set the parameter to an item other than "TV."	48
	No appropriate input source has been selected.	Select an appropriate input source with the <b>ⓇINPUT selector</b> (or <b>ⓂInput selection keys</b> ).	24
	The volume is turned down or muted.	Turn up the volume.	—
	Signals that this unit cannot reproduce are being input from a source component, such as a CD-ROM.	Use an input source whose signals are reproducible on this unit.	—
	A proper audio decoder is not selected.	Display the OPTION menu and set "Decoder Mode" to "Auto."	38
<b>No picture.</b>	The video signal output from this unit is not supported by a monitor connected to this unit via the HDMI OUT jack.	Displays the ADVANCED SETUP menu and select "VIDEO" in "INIT" to reset the video parameters.	55
		Displays the ADVANCED SETUP menu and set "MON.CHK" to "YES."	55
	The VIDEO jack is used to output a component video signal, or the COMPONENT VIDEO jacks are used to output a composite video signal.	If your video monitor does not support the HDMI connection, connect it to the COMPONENT VIDEO jacks and the VIDEO jack and select an appropriate video input on the monitor.	15
	Non-standard video signals are input.	Connect the monitor to this unit via the COMPONENT VIDEO jacks or the VIDEO jack.	15
	An appropriate video input is not selected on the video monitor.	Select an appropriate video input on the video monitor.	—

Problem	Cause	Remedy	See page
<b>No sound is output from a specific speaker.</b>	The speaker is in malfunction.	Check the Speaker indicators on the front panel display. If the corresponding indicator lights up, connect another speaker and check if sound is output. If sound is not output, this unit may be malfunction.	6, 10
	The playback component or speakers are not connected properly.	Connect the cables properly. If the problem persists, the cables may be defective.	11
	Output from that speaker is disabled.	Check the Speaker indicators on the front panel display. If the corresponding indicator is turned off, try the following. 1) Change the input source to another one. 2) With the selected sound field program, sound is not output from that speaker. Select another sound field program. 3) "None" may have been selected for that speaker on this unit. Display Speaker Setup in the SETUP menu and set respective parameters to enable output from that speaker (Speaker Setup → 2 Manual Setup → A)Config).	6, 24, 27, 46
	The volume of that speaker is set to the minimum in Speaker Setup in the SETUP menu.	Display Speaker Setup in the SETUP menu and adjust the volume (2 Manual Setup → B)Level).	47
	(If hardly any sound comes from one channel) Speaker output balance is not properly set.	Set the volume of each speaker to be balanced from "B)Level" in the SETUP menu (Speaker Setup → 2 Manual Setup → B)Level).	47
	Sound may not be output from certain channels depending on the input source or sound field program.	Try another sound field program.	27
<b>Only the center speaker outputs substantial sound.</b>	When a monaural source sound field program is applied, sound of all channels are output from the center speaker for some surround decoders.	Try another sound field program.	27
<b>No sound is heard from the presence speakers.</b>	This unit is in "STRAIGHT" mode.	Press <b>ⓅSTRAIGHT</b> (or <b>ⓈSTRAIGHT</b> ) to exit "STRAIGHT" mode.	30
	This unit is in "STRAIGHT" mode and a monaural source is being played back.	Press <b>ⓅSTRAIGHT</b> (or <b>ⓈSTRAIGHT</b> ) to exit "STRAIGHT" mode.	30
<b>No sound is heard from the surround speakers.</b>	Sound may not be output from certain channels depending on input sources or sound field programs.	Try another sound field program.	27
	<b>No sound is heard from the subwoofer.</b>	A Dolby Digital or DTS signal is reproduced while the LFE channel setting (LFE/Bass Out) of the Speaker Setup in the SETUP menu is set to "Front."	46
	A 2-channel signal is reproduced while the LFE channel setting (LFE/Bass Out) of the Speaker Setup in the SETUP menu is set to "SWFR" or "Front."	Set "LFE/Bass Out" to "Both."	46
	The source does not contain LFE or low frequency signals.		

<b>Problem</b>	<b>Cause</b>	<b>Remedy</b>	<b>See page</b>
<b>No sound is heard from the surround back speakers.</b>	“Extended Surround” in the OPTION menu is set to “Off;” or an input signal does not contain a surround back flag with “Extended Surround” set to “Auto.”	Set “Extended Surround” other than “Off” or “Auto.”	38
<b>The audio input sources cannot be played in the desired digital audio signal format.</b>	The connected component is not set to output the desired digital audio signals.	Set the playback component properly referring to its instruction manuals.	—
<b>There is noise interference from digital or radio frequency equipment.</b>	This unit is too close to other digital or radio frequency equipment.	Move this unit further away from such equipment.	—
<b>Noise/hum noise is heard.</b>	Incorrect cable connection.	Connect the audio cables properly. If the problem persists, the cables may be defective.	—
	No connection from the turntable to the GND terminal.	Connect the grounding cable of the turntable to the GND terminal of this unit.	17
	A DTS-CD is being played back.	1) When only noise is output If a DTS bitstream signal is not properly input to this unit, only noise is output. Connect the playback component to this unit by digital connection and play back the DTS-CD. If the condition is not improved, the problem may result from the playback component. Consult the manufacturer of the playback component. 2) When noise is output during playback or skip operation Before playing back the DTS-CD, display the OPTION menu after selecting the input source and set “Decoder Mode” to “DTS.”	16, 38
<b>The volume level is low while a record is being played.</b>	The record is being played on a turntable with an MC cartridge.	Connect your turntable to this unit through an MC-head amplifier.	17
<b>The volume cannot be increased or the sound is distorted.</b>	The component connected to the output jacks of this unit is not turned on.	When the component connected to the output jacks of this unit is not turned on, the sound may be distorted or the volume may decrease due to the nature of AV receivers. Turn on all components connected to this unit.	—
	“Max Volume” is set to a low value.	Set it to a higher value.	49

**HDMI™**

<b>Problem</b>	<b>Cause</b>	<b>Remedy</b>	<b>See page</b>
<b>No picture or sound.</b>	The number of the connected HDMI components is over the limit.	Disconnect some of the HDMI components.	—
	The connected HDMI component does not support high-bandwidth digital copyright protection (HDCP).	Connect an HDMI component that supports HDCP.	16

## Tuner (FM/AM)

	Problem	Cause	Remedy	See page
FM	<b>FM stereo reception is noisy.</b>	You are too far from the station transmitter or the input from the antenna is weak.	Check the antenna connections.	20
			Replace the outdoor antenna with a more sensitive multi-element antenna.	—
			Switch to monaural mode.	39
	<b>There is distortion, and clear reception cannot be obtained even with a good FM antenna.</b>	There is multi-path interference.	Adjust the antenna height or orientation, or place it in a different location.	—
	<b>The desired station cannot be tuned into with the automatic tuning method.</b>	You are in an area far from a station or an input from the antenna is weak.	Replace an outdoor antenna with more sensitive multi element antenna.	—
Tune in manually or by direct frequency tuning.			31	
<b>The desired station cannot be tuned into with the automatic tuning method.</b>	The signal is weak or the antenna connections are loose.	Adjust the AM loop antenna orientation.	20	
		Use the manual tuning method.	31	
<b>Automatic station preset does not work.</b>	Automatic station preset is not available for AM stations.	Use manual station preset.	32	
AM	<b>There are continuous crackling and hissing noises.</b>	Supplied AM loop antenna is not connected.	Connect the AM loop antenna correctly even if you use an outdoor antenna.	20
		The noises may be caused by lightning, fluorescent lamps, motors, thermostats and other electrical equipment.	It is difficult to completely eliminate noise, but it can be reduced by installing and properly grounding an outdoor AM antenna.	20
	<b>There are buzzing and whining noises.</b>	A TV set is being used nearby.	Move this unit away from the TV set.	—

## Remote control

	Problem	Cause	Remedy	See page
	<b>The remote control does not work or function properly.</b>	Wrong distance or angle.	The remote control will function within a maximum range of 6 m and no more than 30 degrees offaxis from the front panel.	9
		Direct sunlight or lighting (from an inverter type of fluorescent lamp, strobe light, etc.) is striking the remote control sensor of this unit.	Adjust the lighting angle or reposition this unit.	—
		The batteries are weak.	Replace all batteries.	9
		The remote control ID of the remote control and this unit do not match.	Match the remote control ID of this unit and the remote control.	55

Problem	Cause	Remedy	See page
<b>External components cannot be controlled by the remote control.</b>	The remote control code is not correctly set.	Set the remote control code correctly using "List of remote control codes" at the end of this manual.	53
		Try setting another code of the same manufacturer using "List of remote control codes" at the end of this manual.	53
		<p>If this unit does not work when you press <b>[Cursor]</b>, do the following.</p> <p>When the key does not work during DVD disc menu operation: press the <b>[Input selection keys]</b> on the remote control again.</p> <p>When the key does not work during OPTION menu/SETUP menu operation: press the key applicable for the current menu operation again.</p>	—
	Even if the remote control code is correctly set, there are some models that do not respond to the remote control.		

## iPod™

### Note

- In case of a transmission error without a status message appearing on the front panel display and on the OSD, check the connection of your iPod (see page 19).

Problem	Cause	Remedy	See page
Loading...	This unit is in the middle of recognizing the connection with your iPod.		
	This unit is in the middle of acquiring song lists from your iPod.		
Connect error	There is a problem with the signal path from your iPod to this unit.	Turn off this unit and reconnect the Yamaha iPod universal dock to the DOCK jack of this unit.	19
		Remove your iPod in the Yamaha iPod universal dock and then place it back in the dock.	19
Unknown iPod	The iPod being used is not supported by this unit.	Connect an iPod supported by this unit.	—
iPod Connected	Your iPod is properly placed in the Yamaha iPod universal dock.		
Disconnected	Your iPod is removed from the Yamaha iPod universal dock.		
Unable to play	This unit cannot play back the songs currently stored on your iPod.	Check that the songs currently stored on your iPod are playable.	—



## Bluetooth™

Problem	Cause	Remedy	See page
Searchin9...	The Bluetooth wireless audio receiver and the Bluetooth component are in the middle of the pairing. The Bluetooth wireless audio receiver and the Bluetooth component are in the middle of establishing the connection.	/	—
Completed	The pairing is completed.		
Canceled	The pairing is canceled.		
BT Connected	The connection between the Yamaha Bluetooth wireless audio receiver and the Bluetooth component is established.		
Disconnected	The Bluetooth component is disconnected from the Yamaha Bluetooth wireless audio receiver.		
Not found	The Bluetooth component is not found.		

## Auto Setup (YPAO)

### Notes

- If an error or warning message is displayed, resolve the problem and run the automatic setup procedure again.
- Warning message “W-2” or “W-3” indicates that the adjusted settings may not be optimal.
- Depending on the speakers, warning message “W-1” may appear even if the speaker connections are correct.
- If error message “E-10” occurs repeatedly, contact a qualified Yamaha service center.

### Before Auto Setup

Error message	Cause	Remedy	See page
Connect MIC!	Optimizer microphone is not connected.	Connect the supplied optimizer microphone to the OPTIMIZER MIC jack on the front panel.	21
Unplug HP!	Headphones are connected.	Unplug the headphones.	—
Memory Guard!	The parameters of this unit are protected.	Set “Memory Guard” to “Off.”	50

### During Auto Setup

Error message	Cause	Remedy	See page
E-1:NO FRONT SP	Front L/R channel signals are not detected.	Check the front L/R speaker connections.	11
E-2:NO SUR. SP	Only one surround channel signal is detected.	Check the surround L/R speaker connections.	11

Error message	Cause	Remedy	See page
E-3:NO PRNS SP	Only one presence channel signal is detected.	Check the presence L/R speaker connections.	11
E-4:SBR->SBL	Only right surround back channel signal is detected.	If you connect only one surround back speaker, connect it to the L-side (SINGLE) jack.	11
E-5:NOISY	Measurement cannot be performed accurately due to loud ambient noise.	Run the automatic setup procedure again during a time when the environment is quiet.	—
		Turn off noisy electric equipment like air conditioners or move them away from the optimizer microphone.	—
E-6:CHECK SUR.	Surround back speakers are connected, though surround L/R speakers are not.	When using surround back speakers, you need to connect surround L/R speakers.	11
E-7:NO MIC	The optimizer microphone was unplugged during the "Auto Setup" procedure.	Do not touch the optimizer microphone during the automatic setup procedure.	21
E-8:NO SIGNAL	The optimizer microphone does not detect test tones.	Check whether the microphone is properly placed.	21
		Check whether the speakers are properly placed and connected.	11
		The optimizer microphone or OPTIMIZER MIC jack may be defective. Contact the nearest Yamaha dealer or service center.	21
		If a monitor such as a TV is connected to this unit via HDMI connection, sound may not be output from this unit due to the HDMI control function. In such a case, change the monitor setting, for example, change the sound output setting to an amplifier so that sound is output from this unit.	—
E-9:USER CANCEL	The automatic setup procedure was cancelled due to an inappropriate user operation.	Run the automatic setup procedure. Do not adjust the volume or do other operations during the procedure.	21
E-10:INTERNAL ERROR	An internal error occurred.	Run the automatic setup procedure again.	21

### After Auto Setup

Error message	Cause	Remedy	See page
W-1:OUT OF PHASE	Speaker polarity is not correct. This message may appear depending on the speakers even when the speakers are connected correctly.	Check the polarities (+, -) of the displayed speaker. If they are correct, the speakers work properly even when this message is displayed.	11
W-2:OVER 24m (80ft)	The distance between the speaker and the listening position is over 24 m (80 ft).	Bring the speaker within 24 m (80 ft.) area around the listening position.	—
W-3:LEVEL ERROR	The difference of volume level among speakers is excessive.	Recheck the speaker positions and make sure all speakers are placed in a similar environment.	—
		Check the polarities (+, -) of the speakers.	11
		We recommend that you use speakers with the same or similar specifications.	—
		Adjust the output volume of the subwoofer.	—

Error message	Cause	Remedy	See page
W-4: CHECK PRNS	Presence speakers were not detected during measurement with “Extra SP Assign” set to “Presence.”	Check the presence speaker connections and perform measurement again. If presence speakers are not connected, set the “Extra SP Assign” to other than “Presence.”	45
		If presence speakers are connected, set the “Extra SP Assign” to “Presence,” and retry the automatic setup procedure.	45

## ■ Audio and video synchronization (lip sync)

Lip sync, an abbreviation for lip synchronization, is a technical term that involves both a problem and a capability of maintaining audio and video signals synchronized during post-production and transmission. Whereas the audio and video latency requires complex end-user adjustments, HDMI version 1.3 incorporates an automatic audio and video syncing capability that allows devices to perform this synchronization automatically and accurately without user interaction.

## ■ Bi-amplification connection

A bi-amplification connection uses two amplifiers for a speaker. One amplifier is connected to the woofer section of a loudspeaker while the other is connected to the combined mid and tweeter section. With this arrangement each amplifier operates over a restricted frequency range. This restricted range presents each amplifier with a much simpler job and each amplifier is less likely to influence the sound in some way.

## ■ Component video signal

With the component video signal system, the video signal is separated into the Y signal for the luminance and the PB and PR signals for the chrominance. Color can be reproduced more faithfully with this system because each of these signals is independent. The component signal is also called the “color difference signal” because the luminance signal is subtracted from the color signal. A monitor with component input jacks is required in order to output component signals.

## ■ Composite video signal

With the composite video signal system, the video signal is composed of three basic elements of a video picture: color, brightness and synchronization data. A composite video jack on a video component transmits these three elements combined.

## ■ Deep Color

Deep Color refers to the use of various color depths in displays, up from the 24-bit depths in previous versions of the HDMI specification. This extra bit depth allows HDTVs and other displays go from millions of colors to billions of colors and eliminate on-screen color banding for smooth tonal transitions and subtle gradations between colors. The increased contrast ratio can represent many times more shades of gray between black and white. Also Deep Color increases the number of available colors within the boundaries defined by the RGB or YCbCr color space.

## ■ Dolby Digital

Dolby Digital is a digital surround sound system that gives you completely independent multi-channel audio. With 3 front channels (front L/R and center), and 2 surround stereo channels, Dolby Digital provides 5 full-range audio channels. With an additional channel especially for bass effects, called LFE (Low Frequency Effect), the system has a total of 5.1-channels (LFE is counted as 0.1 channel). By using 2-channel stereo for the surround speakers, more accurate moving sound effects and surround sound environment are possible than with Dolby Surround. The wide dynamic range from maximum to minimum volume reproduced by the 5 full-range channels and the precise sound orientation generated using digital sound processing provide listeners with unprecedented excitement and realism. With this unit, any sound environment from monaural up to a 5.1-channel configuration can be freely selected for your enjoyment.

## ■ Dolby Digital Surround EX

Dolby Digital EX creates 6 full-bandwidth output channels from 5.1-channel sources.

For the best results, Dolby Digital EX should be used with movie sound tracks recorded with Dolby Digital Surround EX. With this additional channel, you can experience more dynamic and realistic moving sound especially with scenes with “fly-over” and “fly-around” effects.

## ■ Dolby Digital Plus

Dolby Digital Plus is an advanced audio technology developed for high-definition programming and media including HD broadcasts, and Blu-ray Disc. Selected as an optional audio standard for Blu-ray Disc, this technology delivers multichannel sound with discrete channel output. Supporting bitrates up to 6.0 Mbps, Dolby Digital Plus can carry up to 7.1 discrete audio channels simultaneously. Supported by HDMI version 1.3 and designed for the optical disc players and AV receivers/amplifiers of the future, Dolby Digital Plus also remains fully compatible with the existing multichannel audio systems that incorporate Dolby Digital.

## ■ Dolby Pro Logic II

Dolby Pro Logic II is an improved technique used to decode vast numbers of existing Dolby Surround sources. This new technology enables a discrete 5-channel playback with 2 front left and right channels, 1 center channel, and 2 surround left and right channels instead of only 1 surround channel for conventional Pro Logic technology. There are three modes available: “Music mode” for music sources, “Movie mode” for movie sources and “Game mode” for game sources.

## ■ Dolby Pro Logic IIx

Dolby Pro Logic IIx is a new technology enabling discrete multichannel playback from 2-channel or multi-channel sources. There are three modes available: “Music mode” for music sources, “Movie mode” for movie sources (for 2-channel sources only) and “Game mode” for game sources.

## ■ Dolby Surround

Dolby Surround is widely used with nearly all video tapes and laser discs, and in many TV and cable broadcasts as well. Dolby Surround uses a 4-channel analog recording system to reproduce realistic and dynamic sound effects: 2 front left and right channels (stereo), a center channel for dialog (monaural), and a surround channel for special sound effects (monaural). The surround channel reproduces sound within a narrow frequency range. The Dolby Pro Logic decoder built into this unit employs a digital signal processing system that automatically stabilizes the volume on each channel to enhance moving sound effects and directionality.

## ■ Dolby TrueHD

Dolby TrueHD is an advanced lossless audio technology developed for high-definition disc-based media including Blu-ray Disc. Selected as an optional audio standard for Blu-ray Disc, this technology delivers sound that is bit-for-bit identical to the studio master, offering a high-definition home theater experience. Supporting bitrates up to 18.0 Mbps, Dolby TrueHD can carry up to 8 discrete channels of 24-bit/96 kHz audio simultaneously. Dolby TrueHD also remains fully compatible with the existing multichannel audio systems and retains the metadata capability of Dolby Digital, allowing dialog normalization and dynamic range control.

## ■ DSD

Direct Stream Digital (DSD) technology stores audio signals on digital storage media, such as Super Audio CDs. Using DSD, signals are stored as single bit values at a high-frequency sampling rate of 2.8224 MHz, while noise shaping and oversampling are used to reduce distortion, a common occurrence with very high quantization of audio signals. Due to the high sampling rate, better audio quality can be achieved than that offered by the PCM format used for normal audio CDs. The frequency is equal to or higher than 100 kHz and the dynamic range is 120 dB. This unit can transmit or receive DSD signals via the HDMI jack.

## ■ DTS 96/24

DTS 96/24 offers an unprecedented level of audio quality for multi-channel sound on DVD video, and is fully backward-compatible with all DTS decoders. “96” refers to a 96 kHz sampling rate compared to the typical 48 kHz sampling rate. “24” refers to 24-bit word length. DTS 96/24 offers sound quality transparent to the original 96/24 master, and 96/24 5.1-channel sound with full-quality full-motion video for music programs and motion picture soundtracks on DVD video.

## ■ DTS Digital Surround

DTS Digital Surround was developed to replace the analog soundtracks of movies with a 5.1-channel digital sound track, and is now rapidly gaining popularity in movie theaters around the world. DTS, Inc. has developed a home theater system so that you can enjoy the depth of sound and natural spatial representation of DTS Digital Surround in your home. This system produces practically distortion-free 6-channel sound (technically, front left and right, center, surround left and right, and LFE 0.1 (subwoofer) channels for a total of 5.1 channels). This unit incorporates a DTS-ES decoder that enables 6.1-channel reproduction by adding the surround back channel to the existing 5.1-channel format.

## ■ DTS Express

This is an audio format for next-generation optical discs such as Blu-ray discs. It uses optimized low bit rate signals for network streaming. In the case of a Blu-ray disc, this format is used with secondary audio, enabling you to enjoy the commentary of the movie producer via the Internet while playing the main program.

## ■ DTS-HD High Resolution Audio

DTS-HD High Resolution Audio is a high resolution audio technology developed for high-definition disc-based media including Blu-ray Disc. Selected as an optional audio standard for Blu-ray Disc, this technology delivers sound that is virtually indistinguishable from the original, offering a high-definition home theater experience. Supporting bitrates up to 6.0 Mbps for Blu-ray Disc, DTS-HD High Resolution Audio can carry up to 7.1 discrete channels of 24-bit/96 kHz audio simultaneously.

DTS-HD High Resolution Audio also remains fully compatible with the existing multichannel audio systems that incorporate DTS Digital Surround.

## ■ DTS-HD Master Audio

DTS-HD Master Audio is an advanced lossless audio technology developed for high-definition disc-based media including Blu-ray Disc. Selected as an optional audio standard for Blu-ray Disc, this technology delivers sound that is bit-for-bit identical to the studio master, offering a high-definition home theater experience. Supporting bitrates up to 24.5 Mbps for Blu-ray Disc, DTS-HD Master Audio can carry up to 7.1 discrete channels of 24-bit/96 kHz audio simultaneously. Supported by HDMI version 1.3 and designed for the optical disc players and AV receivers/amplifiers of the future, DTS-HD Master Audio also remains fully compatible with the existing multichannel audio systems that incorporate DTS Digital Surround.

## ■ HDMI

HDMI (High-Definition Multimedia Interface) is the first industry-supported, uncompressed, all-digital audio/video interface. Providing an interface between any source (such as a set-top box or AV receiver) and an audio/video monitor (such as a digital television), HDMI supports standard, enhanced or high-definition video as well as multi-channel digital audio using a single cable. HDMI transmits all ATSC HDTV standards and supports 8-channel digital audio, with bandwidth to spare to accommodate future enhancements and requirements.

When used in combination with HDCP (High-bandwidth Digital Content Protection), HDMI provides a secure audio/video interface that meets the security requirements of content providers and system operators. For further information on HDMI, visit the HDMI website at “<http://www.hdmi.org/>”

## ■ LFE 0.1 channel

This channel reproduces low-frequency signals. The frequency range of this channel is from 20 Hz to 120 Hz. This channel is counted as 0.1 because it only enforces a low-frequency range compared to the full-range reproduced by the other 5/6 channels in Dolby Digital or DTS 5.1/6.1-channel systems.

## ■ Neo:6

Neo:6 decodes the conventional 2-channel sources for 6-channel playback by the specific decoder. It enables playback with the full-range channels with higher separation just like digital discrete signal playback. There are two modes available: “Music mode” for music sources and “Cinema mode” for movie sources.

## ■ PCM (Linear PCM)

Linear PCM is a signal format under which an analog audio signal is digitized, recorded and transmitted without using any compression. This is used as a method of recording CDs and DVD audio. The PCM system uses a technique for sampling the size of the analog signal per very small unit of time. Standing for “Pulse Code Modulation,” the analog signal is encoded as pulses and then modulated for recording.

## ■ Sampling frequency and number of quantized bits

When digitizing an analog audio signal, the number of times the signal is sampled per second is called the sampling frequency, while the degree of fineness when converting the sound level into a numeric value is called the number of quantized bits. The range of rates that can be played back is determined based on the sampling rate, while the dynamic range representing the sound level difference is determined by the number of quantized bits. In principle, the higher the sampling frequency, the wider the range of frequencies that can be played back, and the higher the number of quantized bits, the more finely the sound level can be reproduced.

## ■ “x.v.Color”

A color space standard supported by HDMI version 1.3. It is a more extensive color space than sRGB, and allows the expression of colors that could not be expressed before. While remaining compatible with the color gamut of sRGB standards, “x.v.Color” expands the color space and can thus produce more vivid, natural images. It is particularly effective for still pictures and computer graphics.

# Sound field program information

## ■ CINEMA DSP

Since the Dolby Surround and DTS systems were originally designed for use in movie theaters, their effect is best felt in a theater having many speakers designed for acoustic effects. Since home conditions, such as room size, wall material, number of speakers, and so on, can differ so widely, it is inevitable that there are differences in the sound heard.

Based on a wealth of actually measured data, Yamaha CINEMA DSP provides the audiovisual experience of a movie theater in the listening room of your own home by using the Yamaha original sound field technology combined with various digital audio systems.

## ■ CINEMA DSP 3D

The actually measured sound field data contain the information of the height of the sound images. CINEMA DSP 3D feature achieves the reproduction of the accurate height of the sound images so that it creates the accurate and intensive stereoscopic sound fields in a listening room.

## ■ SILENT CINEMA

Yamaha has developed a natural, realistic sound effect DSP algorithm for headphones. Parameters for headphones have been set for each sound field so that accurate representations of all the sound field programs can be enjoyed on headphones.

## ■ Virtual CINEMA DSP

Yamaha has developed a Virtual CINEMA DSP algorithm that allows you to enjoy DSP sound field surround effects even without any surround speakers by using virtual surround speakers. It is even possible to enjoy Virtual CINEMA DSP using a minimal two-speaker system that does not include a center speaker.

## ■ Compressed Music Enhancer

The Compressed Music Enhancer feature of this unit enhances your listening experience by regenerating the missing harmonics in a compression artifact. As a result, flattened complexity due to the loss of high-frequency fidelity as well as lack of bass due to the loss of low-frequency bass is compensated, providing improved performance of the overall sound system.

# Information on HDMI™

## ■ HDMI signal compatibility

### Audio signals

Audio signal types	Audio signal formats	Compatible media
2ch Linear PCM	2ch, 32-192 kHz, 16/20/24 bit	CD, DVD-Video, DVD-Audio, etc.
Multi-ch Linear PCM	8ch, 32-192 kHz, 16/20/24 bit	DVD-Audio, Blu-ray Disc, HD DVD, etc.
DSD	2/5.1ch, 2.8224 MHz, 1 bit	SACD, etc.
Bitstream	Dolby Digital, DTS	DVD-Video, etc.
Bitstream (High definition audio)	Dolby TrueHD, Dolby Digital Plus, DTS-HD Master Audio, DTS-HD High Resolution Audio, DTS Express	Blu-ray Disc, HD DVD, etc.



- If the input source component can decode the bitstream audio signals of audio commentaries, you can play back the audio sources with the audio commentaries mixed down by using the following connections:
  - multi-channel analog audio input (see page 18)
  - DIGITAL INPUT OPTICAL (or COAXIAL)
- Refer to the supplied instruction manuals of the input source component, and set the component appropriately.

### Notes

- When CPPM copy-protected DVD-Audio is played back, video and audio signals may not be output depending on the type of the DVD player.
- This unit is not compatible with HDCP-incompatible HDMI or DVI components.
- To decode audio bitstream signals on this unit, set the input source component appropriately so that the component outputs the bitstream audio signals directly (does not decode the bitstream signals on the component). Refer to the supplied instruction manuals for details.
- This unit is not compatible with the audio commentary features (for example, the special audio contents downloaded via Internet) of Blu-ray Disc or HD DVD. This unit does not play back the audio commentaries of the Blu-ray Disc or HD DVD contents.

### Video signals

This unit is compatible with the video signals of the following resolutions:

- 480i/60 Hz
- 576i/50 Hz
- 480p/60 Hz
- 576p/50 Hz
- 720p/60 Hz, 50 Hz
- 1080i/60 Hz, 50 Hz
- 1080p/60 Hz, 50 Hz, 24 Hz

# Specifications

## AUDIO SECTION

- Minimum RMS Output Power for Front, Center, Surround, Surround back  
20 Hz - 20 kHz, 0.08% THD, 8 Ω ..... 95 W
- Dynamic Power (IHF)  
Front Speakers 8/6/4/2 Ω ..... 130/165/195/240 W
- Maximum Useful Output Power (JEITA)  
[China, Korea, General and Asia models]  
1 kHz, 10% THD, 8 Ω ..... 135 W
- Maximum Output Power  
[U.K., Europe, Russia and Asia models]  
1 kHz, 0.7% THD, 4 Ω ..... 145 W
- Dynamic Headroom [U.S.A. and Canada models]  
8 Ω ..... 1.4 dB
- IEC Output Power [U.K., Europe, Russia and Asia models]  
Front Speakers 1 kHz, 0.08% THD, 8 Ω ..... 105 W
- Input Sensitivity/Input Impedance  
PHONO  
[China, Korea, U.K., Europe, Russia, Australia, General and Asia models] ..... 3.5 mV/47 kΩ  
AV5, etc. .... 200 mV/47 kΩ  
MULTI CH INPUT ..... 200 mV/47 kΩ
- Maximum Input Voltage  
PHONO (1 kHz, 0.1% THD)  
[China, Korea, U.K., Europe, Russia, Australia, General and Asia models] ..... 60 mV or more  
AV5, etc. (1 kHz, 0.5% THD) ..... 2.3 V or more
- Rated Output Voltage/Output Impedance  
AUDIO OUT ..... 200 mV/1.2 kΩ  
PRE OUT ..... 1.0 V/1.2 kΩ  
SUBWOOFER (2ch Stereo & FRONT: Small)  
..... 1.0 V/1.2 kΩ  
ZONE2 OUT ..... 200 mV/1.2 kΩ
- Headphone Jack Rated Output/Impedance  
AV5, etc. (1 kHz, 50 mV, 8 Ω) ..... 100 mV/470 Ω
- Frequency Response  
AV5, etc. to FRONT ..... 10 Hz to 100 kHz, +0/-3 dB
- RIAA Equalization Deviation  
[China, Korea, U.K., Europe, Russia, Australia, General and Asia models]  
PHONO ..... 0 ± 0.5 dB
- Total Harmonic Distortion  
PHONO to AUDIO OUT  
[China, Korea, U.K., Europe, Russia, Australia, General and Asia models]  
(20 Hz to 20 kHz, 1 V) ..... 0.02% or less  
AV5, etc. to FRONT, Pure Direct  
(20 Hz to 20 kHz, 50 W, 8 Ω) ..... 0.06% or less
- Signal to Noise Ratio (IHF-A Network)  
PHONO Input Shorted (5.0 mV to AUDIO OUT)  
[China and General models]  
..... 86 dB or more  
PHONO Input Shorted (5.0 mV to AUDIO OUT)  
[Korea, U.K., Europe, Russia, Australia and Asia models]  
..... 81 dB or more  
AV5, etc. (Pure Direct) Input Shorted (250 mV to Front Speakers)  
..... 100 dB or more
- Residual Noise (IHF-A Network)  
Front Speakers ..... 150 μV or less
- Channel Separation (1 kHz/10 kHz)  
PHONO (Input Shorted)  
[China, Korea, U.K., Europe, Russia, Australia, General and Asia models] ..... 60 dB/55 dB or more  
AV5, etc. (5.1 kΩ shortened) ..... 60 dB/45 dB or more
- Volume Control ..... MUTE / -80 dB to +16.5 dB
- Tone Control (Front Speakers)  
BASS Boost/Cut ..... ±10 dB at 50 Hz  
BASS Turnover Frequency ..... 350 Hz  
TREBLE Boost/Cut ..... ±10 dB at 20 kHz  
TREBLE Turnover Frequency ..... 3.5 kHz

- Filter Characteristics (fc=40/60/80/90/100/110/120/160/200 Hz)  
H.P.F. (Front, Center, Surround, Surround back: Small)  
..... 12 dB/oct.  
L.P.F. (Subwoofer) ..... 24 dB/oct.

## VIDEO SECTION

- Video Signal Type (Gray Back)  
[U.S.A., Canada, Korea and General models] ..... NTSC  
[Other models] ..... PAL
- Signal Level  
Composite ..... 1 V<sub>p-p</sub>/75 Ω  
S-video [U.K., Europe and Russia models]  
..... 1 V<sub>p-p</sub>/75 Ω (Y), 0.286 V<sub>p-p</sub>/75 Ω (C)  
Component ..... 1 V<sub>p-p</sub>/75 Ω (Y), 0.7 V<sub>p-p</sub>/75 Ω (Cb/Cr)
- Maximum Input Level ..... 1.5 V<sub>p-p</sub> or more
- Signal to Noise Ratio ..... 50 dB or more
- Frequency Response [MONITOR OUT]  
Component ..... 5 Hz to 60 MHz, -3 dB

## FM SECTION

- Tuning Range  
[U.S.A. and Canada models] ..... 87.5 to 107.9 MHz  
[Asia and General models] ..... 87.5/87.50 to 108.0/108.00 MHz  
[Other models] ..... 87.50 to 108.00 MHz
- 50 dB Quieting Sensitivity (IHF)  
Mono ..... 3.0 μV (20.8 dBf)
- Signal to Noise Ratio (IHF)  
Mono/Stereo ..... 74 dB/70 dB
- Harmonic Distortion (1 kHz)  
Mono/Stereo ..... 0.3/0.3%
- Antenna Input (unbalanced) ..... 75 Ω

## AM SECTION

- Tuning Range  
[U.S.A. and Canada models] ..... 530 to 1710 kHz  
[Asia and General models] ..... 530/531 to 1710/1611 kHz  
[Other models] ..... 531 to 1611 kHz

## GENERAL

- Power Supply  
[U.S.A. and Canada models] ..... AC 120 V, 60 Hz  
[General model] ..... AC 110/120/220/230-240 V, 50/60 Hz  
[China model] ..... AC 220 V, 50 Hz  
[Korea model] ..... AC 220 V, 60 Hz  
[Australia model] ..... AC 240 V, 50 Hz  
[U.K., Europe and Russia models] ..... AC 230 V, 50 Hz  
[Asia model] ..... AC 220/230-240 V, 50/60 Hz
- Power Consumption  
[U.S.A. and Canada models] ..... 400 W/500 VA  
[Other models] ..... 400 W
- Standby Power Consumption  
HDMI control off/Standby through off ..... 0.2 W or less  
HDMI control on/Standby through on/No Repeat ..... 1.2 W or less  
HDMI control on/Standby through on/Repeat ..... 3 W or less
- Maximum Power Consumption  
[Asia and General models] ..... 590 W
- Dimensions (W x H x D) ..... 435 x 171 x 365 mm
- Weight ..... 11.0 kg

\* Specifications are subject to change without notice.



# Index

## ■ Numerics

1 Dynamic Range, sound setup .....	47
1 HDMI, function setup .....	48
2 Display, function setup .....	49
2 Lipsync, sound setup .....	48
2ch Stereo, sound field program .....	28
3 Volume, function setup .....	49
3D DSP, sound field parameter .....	40
4 Input Rename, function setup .....	50
5.1-channel speaker layout .....	10
6.1-channel speaker layout .....	10
7.1-channel speaker layout .....	10
7ch Enhancer, sound field program .....	29
7ch Stereo, sound field program .....	28

## ■ A

A)Config, speaker setup .....	45
Action Game, sound field program .....	28
Adaptive DRC, 3 Volume, function setup .....	49
Adjusting high frequency sound .....	25
Adjusting low frequency sound .....	25
ADVANCED SETUP .....	55
Adventure, sound field program .....	27
AM antenna connection .....	20
AM tuning .....	31
ANTENNA jacks, rear panel .....	5
Aspect, 1 HDMI, function setup .....	49
AUDIO 1/2 jacks, rear panel .....	5
Audio and video player connection .....	16
AUDIO jack .....	14
Audio jack .....	14
AUDIO L/R jack, front panel .....	4
AUDIO OUT jacks, rear panel .....	5
Audio Output, 1 HDMI, function setup .....	48
Audio player connection .....	17
Auto Delay, 2 Lipsync, sound setup .....	48
Auto Preset, OPTION menu .....	39
Auto Setup (YPAO), troubleshooting .....	63
Automatic setup .....	21
AV 1-6 jacks, rear panel .....	5
AV OUT jacks, rear panel .....	5

## ■ B

B)Level, speaker setup .....	47
Basic operation, SETUP menu .....	45
BI-AMP connection switch, ADVANCED SETUP .....	55
Bluetooth component playback .....	35
Bluetooth wireless audio receiver connection .....	19
Bluetooth, troubleshooting .....	63

## ■ C

C)Distance, speaker setup .....	47
C.Image, decoder parameter .....	43
Cellar Club, sound field program .....	28
Center SP, A)Config, speaker setup .....	46
Center speaker .....	10
Center width, decoder parameter .....	43
Center, C)Distance, speaker setup .....	47
Chamber, sound field program .....	28
Changing information on the front panel display .....	26
CINEMA DSP 3D indicator, front panel display .....	6
CINEMA DSP basic parameter .....	40
CINEMA DSP indicator, front panel display .....	6
Clear Preset, OPTION menu .....	39
COAXIAL jack .....	14
CODE SET, remote control .....	7
COMPONENT VIDEO jack .....	14
Connect, OPTION menu .....	39
Connecting AM antenna .....	20
Connecting audio and video player .....	16
Connecting audio player .....	17

## Connecting Bluetooth wireless audio

Receiver .....	19
Connecting external amplifier .....	18
Connecting external decoder .....	18
Connecting FM antenna .....	20
Connecting iPod universal dock .....	19
Connecting multi-format player .....	18
Connecting power cable .....	20
Connecting projector .....	15
Connecting set-top box .....	16
Connecting speaker .....	11
Connecting speaker cable .....	13
Connecting TV monitor .....	15
Connecting Zone2 .....	51
Connection .....	10
Control, 1 HDMI, function setup .....	48
Controlling other component, remote control .....	53
Controlling Zone2 .....	52
Crossover Freq., A)Config, speaker setup .....	47
CT Level, sound field parameter .....	43
Cursor indicator, front panel display .....	6
Cursors $\Delta$ / $\nabla$ / $\triangleleft$ / $\triangleright$ , remote control .....	7

## ■ D

D)Equalizer, speaker setup .....	47
Decoder Mode, OPTION menu .....	38
Decoder parameter .....	43
Dialog Lift, sound field parameter .....	41
Dimension, decoder parameter .....	43
Dimmer, 2 Display, function setup .....	49
Direct, sound field parameter .....	43
Disconnect, OPTION menu .....	39
DISPLAY, remote control .....	7
Displaying input signal information .....	26
DOCK jack, rear panel .....	5
Drama, sound field program .....	28
DSP Level, sound field parameter .....	40
DSP Parameter, SETUP menu .....	50

## ■ E

E)Test Tone, speaker setup .....	47
Editing sound field program .....	40
Editing surround decoder .....	40
Effect Level, sound field parameter .....	43
ENTER, remote control .....	7
EQ Type Select, D)Equalizer, speaker setup .....	47
Extended Surround, OPTION menu .....	38
External component operation key, remote control .....	7
Extra SP Assign, A)Config, speaker setup .....	45

## ■ F

FL Scroll, 2 Display, function setup .....	49
FM antenna connection .....	20
FM Mode, OPTION menu .....	39
FM tuning .....	31
FM/AM, front panel .....	4
Frequency tuning mode .....	31
Front L, C)Distance, speaker setup .....	47
Front left speaker .....	10
Front panel .....	4
Front panel display .....	6
Front panel display, front panel .....	4
Front R, C)Distance, speaker setup .....	47
Front right speaker .....	10
Front SP, A)Config, speaker setup .....	46
Function Setup, SETUP menu .....	48

## ■ H

Hall in Munich, sound field program .....	28
Hall in Vienna, sound field program .....	28
HDMI Auto, 2 Lipsync, sound setup .....	48
HDMI indicator, front panel display .....	6
HDMI information .....	69
HDMI jack .....	14

HDMI OUT/HDMI 1-4 jacks, rear panel .....	5
HDMI THROUGH, front panel .....	4
HDMI, troubleshooting .....	60
Headphones using .....	26
Hi-fi sound playback .....	25
High frequency sound adjustment .....	25

## ■ I

INFO, front panel .....	4
INFO, remote control .....	7
INIT, ADVANCED SETUP .....	55
Init. Volume, 3 Volume, function setup .....	49
Initialize setting, ADVANCED SETUP .....	55
Input selection key, remote control .....	7
INPUT selector, front panel .....	4
Input signal information displaying .....	26
Input source registration .....	24
Installing batteries, remote control .....	9
iPod playback .....	33
iPod universal dock connection .....	19
iPod, troubleshooting .....	62

## ■ L

LFE/Bass Out, A)Config, speaker setup .....	46
Low frequency sound adjustment .....	25

## ■ M

MAIN ZONE ON/OFF, front panel .....	4
MAIN/ZONE2, remote control .....	7
Manual Delay, 2 Lipsync, sound setup .....	48
Max Volume, 3 Volume, function setup .....	49
Memory guard, SETUP menu .....	50
MEMORY, front panel .....	4
MON.CHK, ADVANCED SETUP .....	55
MONITOR OUT terminals, rear panel .....	5
Mono Movie, sound field program .....	28
MULTI CH INPUT terminals, rear panel .....	5
Multi information display, front panel display .....	6
Multi-zone configuration .....	51
Music Video, sound field program .....	28
MUTE indicator, front panel display .....	6
MUTE, remote control .....	7

## ■ N

Numeric key, remote control .....	7
-----------------------------------	---

## ■ O

OPTICAL jack .....	14
OPTIMIZER MIC jack, front panel .....	4
OPTION menu .....	37
OPTION, remote control .....	7
OSD Shift, 2 Display, function setup .....	49

## ■ P

Pairing Bluetooth components .....	35
Pairing, OPTION menu .....	39
Panorama, decoder parameter .....	43
PHONES jack, front panel .....	4
PHONO jacks, rear panel .....	5
PL Level, sound field parameter .....	43
Placing speaker .....	10
PORTABLE jack, front panel .....	4
Power cable connection .....	20
Power Cable, rear panel .....	5
POWER, remote control .....	7
PR Level, sound field parameter .....	43
PRE OUT terminals, rear panel .....	5
PRESET $\triangleleft$ / $\triangleright$ , front panel .....	4
Preset tuning mode .....	31
PRNS L, C)Distance, speaker setup .....	47
PRNS R, C)Distance, speaker setup .....	47
PROGRAM selector, front panel .....	4
Projector connection .....	15
PURE DIRECT, front panel .....	4

## ■ R

Registering input source .....	24
Registering sound field program .....	24
Remote control .....	7
Remote control code resetting .....	54
Remote control code setting .....	53
Remote control ID, ADVANCED SETUP .....	55
Remote control signal transmitter, remote control .....	7
Remote control, controlling other component .....	53
Remote control, preparation .....	9
Remote control, troubleshooting .....	61
REMOTE ID, ADVANCED SETUP .....	55
REMOTE IN/OUT jacks, rear panel .....	5
Repeat playback, iPod .....	34
Repeat, OPTION menu .....	39
Resetting remote control code .....	54
Resolution, 1 HDMI, function setup .....	48
RETURN, remote control .....	7
Roleplaying Game, sound field program .....	28

## ■ S

SB Level, sound field parameter .....	43
SCENE function .....	24
SCENE IR, ADVANCED SETUP .....	55
SCENE, front panel .....	4
SCENE, remote control .....	7
Sci-Fi, sound field program .....	27
Selecting SCENE .....	24
Setting remote control code .....	53
Set-top box connection .....	16
SETUP menu .....	44
SETUP menu basic operation .....	45
SETUP, remote control .....	7
Shuffle playback, iPod .....	34
Shuffle, OPTION menu .....	39
Signal Info parameter .....	38
Signal Info, OPTION menu .....	38
SILENT CINEMA .....	30
SL Level, sound field parameter .....	43
SLEEP indicator, front panel display .....	6
Sleep timer .....	36
SLEEP, remote control .....	7
Sound field parameter .....	40
Sound field program editing .....	40
Sound field program registration .....	24
Sound selection key, remote control .....	7
Sound Setup, SETUP menu .....	47
SOURCE POWER, remote control .....	7
SP IMP., ADVANCED SETUP .....	55
Speaker cable connection .....	13
Speaker connection .....	11
Speaker impedance, ADVANCED SETUP .....	55
Speaker indicator, front panel display .....	6
Speaker layout .....	10
Speaker placement .....	10
Speaker setup .....	45
SPEAKERS terminals, rear panel .....	5
Specifications .....	70
Spectacle, sound field program .....	27
Sports, sound field program .....	28
SR Level, sound field parameter .....	43
Standard, sound field program .....	27
Standby Through, 1 HDMI, function setup .....	48
Straight decoding mode .....	30
Straight Enhancer, sound field program .....	29
STRAIGHT, front panel .....	4
Subwoofer .....	10
Subwoofer Phase, A)Config, speaker setup .....	47
Sur. L, C)Distance, speaker setup .....	47
Sur. L/R SP, A)Config, speaker setup .....	46
Sur. R, C)Distance, speaker setup .....	47
SUR., sound field parameter .....	40
Sur.B L, C)Distance, speaker setup .....	47
Sur.B L/R SP, A)Config, speaker setup .....	46
Sur.B R, C)Distance, speaker setup .....	47
Surround back left speaker .....	10
Surround back right speaker .....	10

Surround back speaker .....	10
Surround decoder editing .....	40
Surround left speaker .....	10
Surround right speaker .....	10
SWFR, C)Distance, speaker setup .....	47

## ■ T

The Bottom Line, sound field program .....	28
The Roxy Theatre, sound field program .....	28
Tone control .....	25
TONE CONTROL, front panel .....	4
TRANSMIT, remote control .....	7
TRIGGER OUT jack, rear panel .....	5
Troubleshooting .....	57
Tuner indicator, front panel display .....	6
Tuner key, remote control .....	7
Tuner, troubleshooting .....	61
TUNING ◀ / ▶, front panel .....	4
Tuning, AM .....	31
Tuning, FM .....	31
Turning off .....	20
Turning on .....	20
TV control key, remote control .....	7
TV monitor connection .....	15

## ■ U

Using the remote control .....	9
--------------------------------	---

## ■ V

VIDEO jack .....	14
Video jack .....	14
VIDEO jack, front panel .....	4
Video Out, OPTION menu .....	39
Video/audio jack .....	14
Virtual CINEMA DSP .....	30
VOLUME +/-, remote control .....	7
VOLUME control, front panel .....	4
VOLUME indicator, front panel display .....	6
Volume Trim, OPTION menu .....	37

## ■ Y

YPAO .....	21
YPAO, troubleshooting .....	63

## ■ Z

ZONE2 CONTROL, front panel .....	4
ZONE2 indicator, front panel display .....	6
ZONE2 ON/OFF, front panel .....	4
ZONE2 OUT jacks, rear panel .....	5

“**A** MAIN ZONE ON/OFF” or “**16** POWER” (example) indicates the name of the parts on the front panel or the remote control. Refer to “Controls diagram” or “Part names and functions” on page 4.

## List of remote control codes

TV		Ausind		Clatronic		Durabrand	
A.R. Systems	0274	Autovox	0249	0243, 0249, 0259,		0077, 0097, 0133,	
Acme	0260	Aventura	0249, 0257, 0259,	0260, 0261, 0262,		0225	
Acura	0261, 0273	Awa	0260, 0328	0268, 0269, 0273,		Dux	0271
ADC	0259	Axiom	0097	0274, 0328		Dwin	0224
Admiral	0100, 0224, 0257,	Baird	0327, 0328	CMS		Dynatron	0268, 0271, 0274
	0258, 0259, 0264,	Bang & Olufsen	0206	CMS Hightec		Dynex	0181, 0182
	0265	Basic Line	0328	Coby		Elbe	0243, 0250, 0274,
Advent	0204		0230, 0257	Colorlyme			0328
Adventura	0107		0261, 0262, 0268,	Commercial Solutions		Elcit	0257
Adyson	0260, 0327, 0328	Bastide	0273, 0274, 0328			Electa	0270
Agashi	0327, 0328	Baur	0260, 0328	Concerto		ELECTRO TECH	0261
Agazi	0259	Bazin	0271, 0274	Concorde		Electroband	0057, 0101
Aiko	0260, 0261, 0273,	Beko	0328	Condor		Electrograph	0226
	0274, 0327, 0328		0243, 0269, 0274,			Electrohome	0072, 0090, 0101,
Aim	0274		0282, 0351, 0357,	Contec			0102
Aiwa	0028, 0297	Belcor	0372, 0380			Element	0180
Akai	0063, 0096, 0101,	Bell & Howell	0090	Contec/Cony		Elin	0260, 0268, 0271,
	0205, 0231, 0261,	Benq	0065, 0100				0273, 0274, 0327
	0262, 0268, 0271,	Beon	0051, 0160, 0315	Continental Edison		Elite	0262, 0268, 0274
	0273, 0274, 0327,	Best	0268, 0271, 0274			Elman	0263
	0328	Bestar	0243	Cosmel		Elta	0261, 0273, 0327
Akiba	0262, 0274	Binatone	0243, 0268, 0274	Craig		Emerson	0065, 0072, 0077,
Akura	0259, 0262, 0273,	Blue Sky	0260, 0328	Crosley			0082, 0085, 0090,
	0274	Blue Star	0262, 0274				0094, 0095, 0097,
Alaron	0327	Boots	0270	Crown			0104, 0105, 0119,
Alba	0243, 0260, 0261,	BPL	0260, 0328				0225, 0243, 0257,
	0262, 0266, 0269,	Bradford	0270, 0274				0274
	0271, 0273, 0274,	Brandt	0104, 0225	CS Electronics		Emprex	0200
	0294, 0300, 0327	Brilliant	0267, 0272			Envision	0072, 0090, 0096
Albatron	0222	Brinkmann	0228	CTC Clatronic		Epson	0156, 0201, 0309
Alcyon	0249	Briovega	0274	CTX		Erres	0268, 0271, 0274
Alleron	0105		0257, 0268, 0271,	Curtis Mathes		ESA	0097
Allorgan	0328		0274			ESC	0328
Allstar	0268, 0274	Britannia	0260, 0327, 0328			Etron	0261
America Action	0225	Brockwood	0090	CXC		Eurofeel	0328
AMOi	0326	Broksonic	0063, 0225	Cybertron		Euro-Feel	0259
Amplivision	0243, 0260, 0275,	Bruno	0257	Cytron		Euroline	0271
	0328	BTC	0262	Daewoo		Euroman	0243, 0327, 0328
Amstrad	0259, 0261, 0262,	Bush	0261, 0262, 0264,			Euromann	0259, 0260, 0268,
	0273, 0274		0266, 0268, 0270,				0274
Amtron	0104		0271, 0273, 0274,			Europhon	0260, 0263, 0268,
Anam	0225, 0261		0282, 0286, 0294,				0274, 0327, 0328
Anam National	0102, 0104		0300, 0328, 0329,			Expert	0275
Anglo	0261, 0273		0351, 0388, 0394,			Exquisit	0274
Anitech	0249, 0259, 0261,	Candle	0413	Dainichi		Fenner	0261, 0273
	0273, 0274		0072, 0090, 0096,	Dansai		Ferguson	0267, 0271, 0272
Ansonic	0243, 0250, 0261,	Capsonic	0107			Fidelity	0260, 0264, 0274,
	0263, 0273, 0274	Carena	0259	Dantax			0327
AOC	0072, 0090, 0096,	Carnivale	0274	Dawa		Filsai	0328
	0103	Carrefour	0096	Daytron		Finlandia	0264
Apex	0061, 0117, 0139	Carver	0266			Finlux	0249, 0257, 0260,
Arcam	0327, 0328	Cascade	0088	De Graaf			0263, 0268, 0271,
Arcam Delta	0260	Casio	0261, 0273, 0274	Decca			0274, 0328
Aristona	0268, 0271, 0274	Cathay	0317			FIRST LINE	0260, 0261, 0268
Arthur Martin	0275	CCE	0268, 0271, 0274	Dell		Firstline	0273, 0274, 0327,
ASA	0257, 0265	Celebrity	0229, 0328	Denver			0328
Asberg	0249, 0268, 0274	Celera	0057, 0101	Desmet		Fisher	0065, 0243, 0257,
Astra	0261	Centurion	0117	Diamant			0260, 0266, 0269,
Asuka	0259, 0260, 0262,	Century	0268, 0271, 0274	Diamond			0328
	0327, 0328	CGE	0257	DiamondVision		Flint	0268, 0274
Atlantic	0260, 0268, 0271,	Changhong	0243, 0249	Dimensia		Formenti	0249, 0257, 0258,
	0274, 0327	Chimei	0117	Disney			0260, 0271, 0327
Atori	0261, 0273	Cimline	0323	Dixi		Formenti/Phoenix	0327
Auchan	0275	Citizen	0261, 0273			Fortress	0257, 0258
Audiosonic	0243, 0260, 0261,	City	0072, 0085, 0090,	Dream Vision		Fraba	0243, 0274
	0262, 0268, 0271,	Clarion	0096, 0104	DTS		Friac	0243
	0274, 0328	Clarivox	0261, 0273	Dual		Frontech	0259, 0261, 0264,
AudioTon	0243, 0260, 0328		0225	Dual-Tec			0265, 0273, 0328
Audiovox	0104, 0144, 0225		0271	Dumont		Fujitsu	0023, 0024, 0025,
							0105, 0328
						Fujitsu General	0328

Fujitsu Siemens	0425, 0426, 0427, 0428, 0429	Hinari	0261, 0262, 0266, 0268, 0271, 0273, 0274	Kaisui	0260, 0261, 0262, 0270, 0273, 0274, 0327, 0328	Magnavox	0072, 0088, 0090, 0091, 0095, 0096, 0098, 0114, 0115, 0129, 0134, 0176, 0178, 0189, 0210
Funai	0033, 0034, 0035, 0036, 0037, 0097, 0104, 0105, 0225, 0259	Hisawa Hisense Hitachi	0262, 0270, 0275 0165 0006, 0014, 0015, 0016, 0042, 0072, 0090, 0094, 0173, 0254, 0255, 0256, 0260, 0264, 0265, 0266, 0274, 0285, 0300, 0319, 0328, 0348, 0349, 0385, 0402, 0410	Kamosonic Kamp Kapsch Karcher	0260 0260, 0327 0265 0243, 0260, 0261, 0271, 0274	Magnum Majestic Mandor	0259, 0261 0100 0259
Futuretech	0104, 0225			Kawasho	0072, 0090, 0101, 0327	Manesth	0259, 0260, 0268, 0271, 0274, 0328
Galaxi	0269, 0274			KEC	0225	Marantz	0072, 0088, 0090, 0096, 0158, 0268, 0271, 0274
Galaxis	0243, 0274			Kendo	0243, 0263, 0264, 0274		
Gateway	0163, 0226, 0227			Kenwood	0072, 0090, 0096	Marelli	0257
GBC	0261, 0266, 0273			KIC	0328	Mark	0268, 0271, 0273, 0274, 0327, 0328
GE	0069, 0071, 0072, 0073, 0077, 0090, 0099, 0102, 0106, 0112, 0131	Hornophon	0268, 0274	Kingsley	0260, 0327		
Geant Casino	0275	Hoshai	0262	KLH	0117	Masuda	0328
GEC	0260, 0265, 0268, 0271, 0274, 0328	Huanyu	0260, 0327, 0328	Kloss Novabeam	0104, 0107	Matsui	0260, 0261, 0264, 0266, 0268, 0271, 0273, 0274, 0328, 0405
Geloso	0261, 0264, 0273	Hygashi	0260, 0261, 0273, 0327, 0328	Kneissel	0243, 0250, 0274		
General Technic	0261, 0273	Hyper	0260, 0261, 0273, 0259, 0260, 0268, 0270, 0271, 0274, 0275, 0328	Kolster	0268, 0274		
Genexxa	0262, 0265, 0268, 0274	Hypson	0259, 0260, 0268, 0270, 0271, 0274, 0275, 0328	Konka	0262	Matsushita	0067
GFM	0177, 0210			Korpel	0268, 0271, 0274	Maxent	0193, 0226
Giant	0328	Hyundai	0223	Korting	0243, 0257	Mediator	0268, 0271, 0274
Gibraltar	0076, 0090, 0096, 0108	Iberia	0274	Kosmos	0274	Medion	0259, 0261, 0274
GoldHand	0327	ICE	0259, 0260, 0261, 0262, 0268, 0273, 0274, 0327, 0328	Koyoda	0261	Megapower	0222
Goldline	0274			KTV	0085, 0096, 0104, 0225, 0229, 0260, 0328	Megatron	0072, 0077
GoldStar	0072, 0077, 0085, 0090, 0094, 0096, 0103, 0243, 0260, 0261, 0264, 0268, 0271, 0273, 0274, 0327, 0328	ICeS	0327	Kyoto	0327, 0328	MElectronic	0273, 0274, 0327, 0328
		Ilo	0198, 0203	Lasat	0243	Melvox	0275
		IMA	0104	Lenco	0261, 0273	Memorex	0065, 0072, 0077, 0100, 0103, 0133, 0219, 0261, 0273
		Imperial	0243, 0249, 0265, 0268, 0269, 0274	Lenoir	0260, 0261, 0273		
		Indiana	0268, 0271, 0274	Leyco	0259, 0268, 0271, 0274	Memphis	0261, 0273
Goodmans	0164, 0259, 0261, 0266, 0268, 0271, 0273, 0274, 0322, 0328, 0395, 0399, 0412	Infinity	0088	LG	0016, 0038, 0039, 0077, 0103, 0145, 0222, 0243, 0246, 0253, 0260, 0261, 0264, 0268, 0271, 0273, 0274, 0282, 0290, 0299, 0316, 0327, 0328, 0351, 0359, 0367, 0382, 0384, 0389, 0396	Mercury	0273, 0274
		InFocus	0168, 0277, 0313, 0397, 0430			Metz	0257
		Ingelen	0265			MGA	0072, 0077, 0090, 0096, 0103
		Ingersol	0261, 0273			Micromaxx	0259, 0261
Gorenje	0243, 0269	Initial	0203			Microstar	0259, 0261
GPM	0262	Inno Hit	0249, 0260, 0261, 0262, 0268, 0271, 0273, 0274, 0328			Midland	0069, 0071, 0073, 0076, 0085, 0106, 0108
GPX	0211						0249
Gradiente	0162						0249
Graetz	0265	Innovation	0259, 0261			Minerva	0249
Granada	0249, 0260, 0264, 0266, 0268, 0271, 0274, 0275, 0328	Insignia	0182, 0188, 0190, 0209	LG/GoldStar	0246	Minoka	0268, 0274
		Inteq	0076	Liesenk	0271	Mintek	0203
Grandin	0261, 0262, 0270, 0271	Interactive	0243	Liesenkotter	0274	Mitsubishi	0006, 0015, 0016, 0048, 0072, 0077, 0090, 0103, 0196, 0224, 0257, 0266, 0268, 0274, 0298, 0371
		Interbuy	0261, 0273	Life	0259, 0261		
Gronic	0328	Interfunk	0243, 0257, 0265, 0268, 0271, 0274	Lifetec	0259, 0261, 0273, 0274		
Grundig	0242, 0243, 0249, 0274, 0356	International	0327	Lloyds	0273		
Grunpy	0104, 0105, 0225	Intervision	0243, 0259, 0260, 0263, 0274, 0328	Loewe	0243, 0250, 0274, 0280, 0306, 0347	Mivar	0243, 0249, 0250, 0260, 0327, 0328
Haier	0187, 0207			Loewe Opta	0257, 0268, 0271		
Halifax	0259, 0260, 0327, 0328	Irradio	0249, 0261, 0262, 0268, 0271, 0273, 0274	Logik	0100	Monivision	0222
Hallmark	0072, 0077, 0090			Luma	0264, 0271, 0273, 0274	Montgomery Ward	0100
Hampton	0260, 0327, 0328	Isukai	0262, 0274	Lumatron	0264, 0268, 0271, 0274, 0328	Motion	0249
Hanseatic	0243, 0250, 0260, 0261, 0266, 0268, 0271, 0273, 0274, 0328	ITC	0260, 0328	Lux May	0268	Motorola	0102, 0224
		ITS	0262, 0268, 0270, 0274, 0327	Luxman	0072, 0090	MTC	0072, 0090, 0096, 0103, 0243, 0327
		ITT	0261, 0265	Luxor	0260, 0264, 0328	Multi System	0271
Hantarex	0261, 0273, 0274	ITV	0261, 0271, 0274	LXI	0061, 0065, 0071, 0072, 0073, 0077, 0088, 0099	Multitech	0104, 0225, 0229, 0243, 0260, 0261, 0263, 0264, 0266, 0271, 0273, 0274, 0327, 0328
Hantor	0274	Janeil	0107				
Harman/Kardon	0088	JBL	0088			Murphy	0260, 0327
Harvard	0104, 0225	JC Penney	0072, 0073, 0085, 0090, 0099, 0103, 0106	M Electronic	0260, 0261, 0265, 0267, 0268, 0271	NAD	0061, 0072, 0077
Harwood	0273, 0274			MAG	0050	Naonis	0264
Havermy	0224	JCB	0057, 0101	Magnadyne	0257, 0263, 0271	NEC	0026, 0053, 0072, 0090, 0096, 0102, 0103, 0266, 0328
HCM	0259, 0260, 0261, 0270, 0273, 0274, 0328	Jensen	0072, 0090	Magnafon	0249, 0260, 0263, 0327		
		JVC	0017, 0018, 0019, 0092, 0093, 0094, 0106, 0251, 0252, 0266, 0268, 0293, 0360, 0379				
Hema	0273, 0328						
Hewlett Packard	0146						
Higashi	0327						
HiLine	0274						

Neckermann	0243, 0257, 0260, 0264, 0268, 0269, 0271, 0274, 0328		0114, 0135, 0143, 0176, 0178, 0189, 0210, 0212, 0232, 0233, 0257, 0260, 0268, 0271, 0274, 0278, 0287, 0301, 0302, 0307, 0311, 0314, 0330, 0331, 0333, 0337, 0338, 0339, 0341, 0343, 0345, 0355, 0363, 0365, 0377, 0378, 0381, 0383, 0406, 0409, 0414	RCA	0071, 0072, 0073, 0074, 0075, 0090, 0099, 0102, 0103, 0109, 0120, 0179, 0218	SEI-Sinudyne	0257, 0263, 0265 0264, 0265, 0266 0261, 0273 0273 0327	
NEI	0268, 0271, 0274			Realistic	0065, 0077, 0096, 0225	Sharp	0009, 0010, 0011, 0072, 0080, 0081, 0082, 0083, 0085, 0090, 0094, 0110, 0148, 0183, 0216, 0224, 0247, 0248, 0258, 0266, 0288, 0304, 0324, 0325, 0340, 0358, 0362, 0369, 0386, 0392, 0398, 0400, 0401, 0403	
Net-TV	0226			Recor	0274			
Neufunk	0273, 0274			Redstar	0274			
New Tech	0261, 0268			Reflex	0274			
New World	0262			Revox	0243, 0268, 0271, 0274			
NewTech	0273, 0274, 0328			Rex	0259, 0264, 0265			
Nicamagic	0260, 0327			RFT	0243, 0250, 0257			
Nikkai	0259, 0260, 0262, 0268, 0271, 0273, 0274, 0327, 0328			Rhapsody	0327			
Nikko	0072, 0077, 0096			R-Line	0268, 0271, 0274			
Noblisko	0249, 0260, 0263, 0327	Philips Magnavox Phoenix	0089, 0114, 0115 0243, 0257, 0268, 0271, 0274, 0327	Roadstar	0259, 0261, 0262, 0273	Sheng Chia	0224	
Nokia	0265			Robotron	0257	Shogun	0090	
Norcent	0155	Phonola	0257, 0268, 0271, 0274, 0327	Rowa	0327, 0328	Siarem	0257, 0263, 0274	
Nordic	0328			Royal Lux	0243	Sierra	0268, 0274	
Nordmende	0257, 0265, 0267, 0268	Pilot	0085, 0090, 0096	RTF	0257	Siesta	0243	
Nordvision	0271	Pioneer	0012, 0013, 0072, 0090, 0243, 0265, 0267, 0268, 0271, 0274, 0408	Runco	0076, 0096, 0108	Signature	0100	
Novatronic	0274			Saba	0257, 0265, 0267, 0272, 0376	Silva	0327	
Oceanic	0265, 0275			Saisho	0259, 0260, 0261, 0273, 0328	Silver	0266	
Okano	0243, 0269, 0274	Plantron	0259, 0268, 0273, 0274			Singer	0257, 0263, 0275	
Olevia	0052, 0140, 0149, 0154, 0157					Sinudyne	0257, 0263, 0271, 0274	
ONCEAS	0260	Polaroid	0117, 0152, 0184, 0220	Salora	0264, 0265	Skantic	0265	
Onwa	0104, 0225			Sambers	0249, 0263	Solavox	0265	
Opera	0274	Poppy	0261, 0273	Sampo	0072, 0085, 0090, 0096, 0226	Sonitron	0243, 0328	
Oppo	0208	Portland	0072, 0085, 0090, 0103	Samsung	0029, 0030, 0031, 0032, 0044, 0045, 0046, 0047, 0072, 0077, 0084, 0085, 0086, 0087, 0090, 0094, 0096, 0103, 0118, 0217, 0229, 0235, 0236, 0237, 0243, 0259, 0260, 0261, 0268, 0269, 0271, 0273, 0274, 0284, 0295, 0327, 0328, 0336, 0346, 0390, 0407		Sonolor	0265, 0275
Optimus	0065, 0067					Sontec	0243, 0268, 0271, 0274	
Optoma	0194	Prandoni-Prince	0249, 0264			Sony	0041, 0057, 0058, 0059, 0060, 0101, 0116, 0125, 0126, 0127, 0142, 0169, 0170, 0171, 0172, 0174, 0234, 0261, 0266, 0276, 0289, 0292, 0393, 0411	
Optonica	0224	Precision	0260, 0328				0262, 0263	
Orbit	0268, 0274	Prima	0161, 0207, 0261, 0265, 0273				0104, 0105, 0225	
Orion	0121, 0192, 0261, 0268, 0271, 0273, 0274, 0282, 0329	Princeton	0222				0268, 0271, 0274	
Orline	0274	Prism	0069, 0106				0097	
Osaki	0259, 0260, 0262, 0274, 0328	Profex	0261, 0273				0090, 0104, 0225	
Oso	0262	Profi-Tronic	0268, 0274				0260, 0261, 0262, 0268, 0273, 0274, 0328	
Otto Versand	0258, 0260, 0266, 0268, 0270, 0271, 0274, 0328	Proline	0268, 0274				0104, 0225, 0271, 0273, 0274	
		Proscan	0071, 0073, 0099				0270	
		Prosonic	0243, 0260, 0271, 0274, 0327, 0328				0264, 0265	
		Protech	0259, 0260, 0261, 0263, 0268, 0271, 0328	Sandra	0260, 0327, 0328	Sound & Vision	0072, 0077, 0090, 0104, 0105, 0225	
Pael	0260, 0327			Sansui	0063, 0121, 0268, 0274	Soundesign	0268, 0271, 0274	
Palladium	0243, 0260, 0269, 0274, 0328	Proton	0072, 0077, 0090, 0094	Sanyo	0020, 0021, 0022, 0049, 0065, 0090, 0141, 0191, 0243, 0250, 0260, 0266, 0273, 0291, 0327, 0328, 0370, 0373, 0391	Soundwave	0268, 0271, 0274	
Palsonic	0328					Squareview	0097	
Panama	0259, 0260, 0261, 0273, 0274, 0327, 0328	Protron	0150			SSS	0090, 0104, 0225	
Panasonic	0006, 0007, 0066, 0067, 0068, 0069, 0070, 0102, 0106, 0113, 0147, 0215, 0241, 0265, 0274, 0279, 0310, 0332, 0334, 0368, 0374	PROVIEW	0050, 0164			Standard	0260, 0261, 0262, 0268, 0273, 0274, 0328	
		Provision	0271, 0274				0104, 0225, 0271, 0273, 0274	
		Pulsar	0076, 0090, 0108				0266, 0276, 0289, 0292, 0393, 0411	
		Pye	0268, 0271, 0274, 0296, 0338				0262, 0263	
		Pymi	0261, 0273	SBR	0271, 0274	Starlite	0104, 0225, 0271, 0273, 0274	
		Quandra Vision	0275	Sceptre	0166, 0185	Stenway	0270	
		Quasar	0067, 0069, 0102, 0106	Schaub Lorenz	0265	Stern	0264, 0265	
Panavision	0274	Quelle	0259, 0260, 0268, 0271, 0274, 0328	Schneider	0260, 0262, 0268, 0271, 0274, 0287, 0300, 0328, 0364, 0366	Strato	0273, 0274	
Pathe Cinema	0243, 0250, 0260, 0275, 0327	Questa	0266			Stylandia	0328	
Pausa	0261, 0273	Radialva	0274	Scotch	0072, 0077	Sunkai	0261	
Penney	0061, 0069, 0071, 0077, 0096	RadioShack	0065, 0071, 0077, 0096, 0225, 0274	Scott	0072, 0077, 0090, 0094, 0104, 0105, 0199, 0225	Sunstar	0273, 0274	
Perdio	0274, 0327					Sunwood	0261, 0268, 0273, 0274	
Perfekt	0274	RadioShack/Realistic	0072, 0085, 0090, 0094, 0099, 0104				0260, 0327, 0328	
Philco	0072, 0088, 0090, 0091, 0094, 0096, 0102, 0103, 0243, 0249, 0257, 0274	Radiola	0268, 0271, 0274, 0328	Sears	0061, 0065, 0071, 0072, 0073, 0077, 0088, 0090, 0097, 0099, 0105	Superscan	0095, 0224	
		Radiomarelli	0257, 0274			SuperTech	0273, 0274, 0327	
Philharmonic	0260, 0328	Radiotone	0243, 0268, 0273, 0274	SEG	0259, 0260, 0263, 0266, 0271, 0273, 0274, 0300, 0327, 0328	Supra	0261, 0273	
Philips	0040, 0088, 0089, 0090, 0091, 0094, 0098, 0099, 0102,	Rank	0266			Supre-Macy	0107	
						Supreme	0057, 0101	
						Susumu	0262	
						Sutron	0261, 0273	
						SVA	0197	
						Sydney	0260, 0327, 0328	
				SEI	0274			

Sylvania	0072, 0088, 0089, 0090, 0091, 0095, 0096, 0097, 0098, 0175, 0177, 0210	Triumph	0274	Adventura	1023	Dumont	1072, 1078
		Uher	0243, 0249, 0265, 0268, 0274	Adyson	1090	Durabrand	1032
		Ultravox	0257, 0260, 0263, 0274, 0327	Aiwa	1023, 1072, 1073, 1074	Dynatech	1023
Symphonic	0097, 0104, 0108, 0133, 0210, 0225	Unic Line	0274	Akai	1071, 1073	Echostar	1064
Syntax	0149	United	0271	Akiba	1079, 1090	Elbe	1091
Syntax-Brilliant	0149	Universum	0243, 0249, 0259, 0268, 0269, 0271, 0274, 0328	Akura	1073, 1079, 1090	Elcatech	1090
Sysline	0271			Alba	1074, 1075, 1076, 1079, 1090, 1091	Electrohome	1021
Sytong	0327			Alienware	1066	Electrohome	1021
Tandy	0224, 0258, 0260, 0262, 0265, 0328	Univox	0274	Ambassador	1076	Elsay	1090
		Vector Research	0096	American High	1022	Elta	1079, 1090, 1091
Tashiko	0260, 0264, 0266, 0327, 0328	Vestel	0264, 0265, 0268, 0269, 0271, 0274, 0328	Amstrad	1072, 1090, 1091	Emerson	1021, 1022, 1023, 1070, 1090
Tatung	0102, 0227, 0260, 0268, 0271, 0274, 0328	Vexa	0261, 0271, 0273, 0274	Anitech	1079, 1090	ESC	1075, 1091
TCM	0259, 0261	Victor	0093, 0266, 0268	Apex	1010	Etzuko	1079, 1090
Teac	0274, 0328	VIDEOLÓGIC	0327	ASA	1077, 1078	Expressvu	1064
Tec	0260, 0261, 0273, 0328	Videologique	0260, 0262, 0327, 0328	Asha	1020	Ferguson	1073
Technics	0067, 0069, 0106	VideoSystem	0268, 0274	Asuka	1072, 1077, 1078, 1079, 1090	Fidelity	1072, 1090
TechniSat	0320, 0417, 0418, 0419	Videotechnic	0327, 0328	Audio Dynamics	1018	Finlandia	1078
		Vidikron	0088	Audiosonic	1091	Finlux	1072, 1073, 1078
Techwood	0069, 0072, 0090, 0106	Vidtech	0072, 0077, 0090, 0103	Audiovox	1021	Firstline	1074, 1077, 1079, 1090
TEDELEX	0328	Viewsonic	0153, 0186, 0226, 0318	Baird	1072, 1073, 1075, 1091	Fisher	1019
Teknika	0072, 0085, 0088, 0090, 0094, 0100, 0103, 0104, 0105, 0225	Viking	0107	Bang & Olufsen	1067	Flint	1074
		Viore	0198	Basic Line	1074, 1075, 1076, 1079, 1090, 1091	Formenti/Phoenix	1078
Televia	0267	Visiola	0260, 0327	Baur	1078	Frontech	1076
Telecor	0274, 0328	Vision	0268, 0274, 0328	Beaumarck	1020	Fuji	1022
Telefunken	0267, 0268, 0272, 0274	Vizio	0090, 0136, 0160, 0227, 0420, 0421, 0422, 0423, 0424	Bell & Howell	1019	Fujitsu	1072
Telegazi	0274	Vortec	0268, 0271, 0274	Bestar	1075, 1076, 1091	Funai	1023, 1072
Telemeister	0274	Voxson	0249, 0257, 0264, 0265, 0268, 0274	Black Panther Line	1075, 1091	Galaxy	1072
Telesonic	0274	Waltham	0260, 0274, 0328	Blaupunkt	1078	Garrard	1023
Telestar	0274	Wards	0072, 0077, 0088, 0090, 0091, 0096, 0098, 0099, 0100, 0103, 0105	Bondstec	1076, 1090	Gateway	1066
Teletech	0261, 0271, 0273, 0274			Broksonic	1054	GBC	1076, 1079
Teleton	0260, 0328	Watson	0268, 0271, 0274	Bush	1074, 1075, 1079, 1090, 1091, 1097, 1099, 1109, 1139	GE	1020, 1022
Televideon	0327	Watt Radio	0260, 0263, 0327	Calix	1021	GEC	1078
Televideo	0275	Waycon	0061	Candle	1020, 1021	Geloso	1079
Tensai	0261, 0262, 0268, 0273, 0274, 0328	Wega	0257, 0266, 0274	Canon	1022	General	1076
Tesmet	0268	Wegavox	0273	Cathay	1091	General Technic	1074
Tevion	0259, 0261	Weltblick	0268, 0271, 0274, 0328	Catron	1076	GOI	1064
Textet	0260, 0273, 0327, 0328	Westinghouse	0057, 0138, 0142	CGE	1072, 1073	GoldHand	1079, 1090
Thomson	0238, 0239, 0240, 0260, 0267, 0268, 0272, 0274, 0335	White Westinghouse	0008, 0119, 0260, 0263, 0271, 0274, 0327	CineVision	1058	Goldstar	1018, 1021, 1072, 1077
				Citizen	1020, 1021	Goodmans	1072, 1075, 1076, 1077, 1079, 1090, 1091
Thorn	0072, 0077, 0090			Clatronic	1076, 1090	Gradiente	1023
TMK	0072, 0077, 0090			Colortyme	1018	Graetz	1073
TNCi	0076	Wincom	0055, 0056	Condor	1075, 1076, 1091	Granada	1078
Tokai	0268, 0274, 0328	Xrypton	0274	Craig	1020, 1021	Grandin	1072, 1075, 1076, 1077, 1079, 1090, 1091
Tokyo	0260, 0327	Yamaha	0000, 0001, 0002, 0003, 0004, 0005, 0103	Crown	1075, 1076, 1079, 1090, 1091	Harley Davidson	1023
Tomashi	0270			Curtis Mathes	1018, 1020, 1022	Harmann/Kardon	1018
Toshiba	0027, 0043, 0053, 0054, 0061, 0062, 0063, 0064, 0065, 0122, 0123, 0124, 0128, 0130, 0132, 0139, 0214, 0244, 0266, 0283, 0305, 0328, 0329, 0342, 0350, 0352, 0353, 0354, 0375, 0404	Yamishi	0274, 0328	Cyberberx	1020	Harwood	1090
		Yokan	0274	CyberPower	1066	HCM	1079, 1090
		Yoko	0243, 0259, 0260, 0261, 0262, 0268, 0271, 0273, 0274, 0327, 0328	Daewoo	1023, 1075, 1076, 1091, 1116, 1141	Headquarter	1019
				Dansai	1079, 1090, 1091	Hewlett Packard	1066
				Dantax	1074	Hinari	1074, 1079, 1090, 1091
				Daytron	1075, 1091	Hisawa	1074
				DBX	1018	Hitachi	1072, 1073, 1078, 1089, 1108, 1124
				De Graaf	1078	HNS	1060
				Decca	1072, 1073, 1078	Howard Computers	1066
				Dell	1066	HP	1066
				Denko	1090	HTS	1064
		Yorx	0262	DiamondVision	1050	Hughes	1035, 1040, 1061
		Zanussi	0264, 0328	DigiFusion	1092	Hughes Network Systems	1038, 1060
Totevision	0085	Zenith	0076, 0077, 0078, 0079, 0090, 0100, 0108, 0111	DIRECTV	1035, 1038, 1040, 1059, 1060, 1061, 1065	Humax	1035, 1060, 1094
Towada	0265, 0328			Dish Network	1064	Hush	1066
Trakton	0328			Dishpro	1064	Hypson	1074, 1079, 1090, 1091
Trans Continens	0274, 0328			Dual	1073, 1078, 1091		
Transtec	0327	<b>VCR</b>					
Trident	0328	ABS	1066				

iBUYPOWER	1066	Multitech	1020, 1023, 1072,	Ricavision	1066	Telefunken	1073
Impego	1076		1076, 1078, 1079,	Roadstar	1075, 1077, 1079,	Teletech	1090, 1091
Imperial	1072		1090		1090, 1091	Tenosal	1079, 1090
Inno Hit	1075, 1076, 1078,	Murphy	1072	Royal	1090	Tensai	1072, 1077, 1079,
	1079, 1090, 1091	NEC	1018, 1019, 1073	Runco	1032		1090
Innovation	1074	Neckermann	1073, 1078	Saba	1073	Tevion	1074
Instant Replay	1022	NEI	1078	Saisho	1074, 1079	Thomson	1073, 1087
Interbuy	1077, 1090	Nesco	1079, 1090	Samsung	1006, 1020, 1038,	Thorn	1073
Interfunk	1078	Nikkai	1076, 1090, 1091		1040, 1046, 1060,	Tivo	1035, 1036, 1037,
Intervision	1072, 1091	Nikko	1021		1080, 1107, 1110,		1039, 1040, 1060,
Irradio	1077, 1079, 1090	Niveus Media	1066		1112, 1121, 1123,		1061, 1062
ITT	1073	Noblex	1020		1140, 1142	TMK	1020
ITV	1075, 1077, 1091	Nokia	1073, 1091	Samurai	1076, 1090	Tokai	1077, 1079, 1090
JC Penney	1018, 1019, 1020,	Nordmende	1073	Sanky	1032	Tonsai	1079
	1021, 1022	Northgate	1066	Sansui	1033, 1056, 1069,	Toshiba	1004, 1005, 1034,
JCL	1022	Oceanic	1072, 1073		1073		1051, 1063, 1066,
JVC	1011, 1012, 1013,	Okano	1074, 1090, 1091	Sanyo	1019, 1020, 1114		1073, 1078, 1086,
	1014, 1015, 1016,	Olympus	1022	Saville	1091		1099, 1102, 1119,
	1017, 1018, 1019,	Optimus	1021	SBR	1078		1144
	1028, 1035, 1064,	Orion	1033, 1069, 1074,	Schaub Lorenz	1072, 1073	Totevision	1020, 1021
	1073, 1085, 1117,		1097, 1139	Schneider	1072, 1074, 1075,	Touch	1066
	1130, 1131, 1133,	Orson	1072		1076, 1077, 1078,	Towada	1079, 1090
	1134, 1135, 1136	Osaki	1072, 1077, 1079,		1079, 1090, 1091	Towika	1079, 1090
	1079, 1090		1090	Sears	1019, 1021, 1022	TVA	1076
Kaisui		Otto Versand	1078	SEG	1079, 1090, 1091	Uher	1077
Karcher	1078	Palladium	1073, 1077, 1079,	SEI-Sinudyne	1078	UltimateTV	1065
Kendo	1074, 1075, 1076,		1090	Selec	1073	Ultravox	1091
	1090	Panasonic	1007, 1008, 1009,	Sentra	1076, 1090	Unitech	1020
Kenwood	1018, 1019, 1073		1022, 1026, 1042,	Sentron	1079, 1090	United Quick Star	1075, 1091
Kodak	1021, 1022		1043, 1068, 1082,	Sharp	1031, 1045, 1057,	Universum	1072, 1077, 1078
Korpel	1079, 1090		1101, 1126, 1132		1081, 1115, 1137	Vector Research	1018
Kyoto	1090	Pathe Marconi	1073	Shintom	1079, 1090	Video Concepts	1018
Lenco	1075	Perdio	1072	Shivaki	1077	Videon	1074
Leyco	1079, 1090	Philco	1022, 1090	Shogun	1020	Videosonic	1020
LG	1021, 1053, 1072,	Philips	1022, 1030, 1035,	Siemens	1077	Viewsonic	1066
	1077, 1088, 1100,		1038, 1039, 1040,	Silva	1077	Voodoo	1066
	1106, 1125, 1143		1044, 1055, 1060,	Silver	1091	Wards	1020, 1021, 1022,
Lifetec	1074		1078, 1084, 1095,	Singer	1022		1023
Linksys	1066		1096, 1104, 1105,	Sinudyne	1078	Weltblick	1077
Lloyd's	1023		1111, 1113, 1122,	Solavox	1076	XR-1000	1022, 1023
Loewe Opta	1077, 1078		1124, 1127, 1128,	Sonic Blue	1041, 1068	Yamaha	1018, 1019
Logik	1079, 1090		1129	Sonneclair	1090	Yamishi	1079, 1090
Lumatron	1075, 1091			Sonoko	1075, 1091	Yokan	1079, 1090
Luxor	1090	Philips Magnavox	1030	Sontec	1077	Yoko	1076, 1077, 1079,
LXI	1021	Phonola	1078	Sony	1000, 1001, 1002,		1090
M Electronic	1072	Pilot	1021		1003, 1024, 1027,	Zenith	1032
Magnavox	1022, 1032, 1044,	Pioneer	1078, 1118		1036, 1062, 1066,	ZT Group	1066
	1070	Polaroid	1010, 1049	Stack	1066		
Magnin	1021	Portland	1075, 1076, 1091	Stack 9	1066	<b>DVD</b>	
Manesth	1079, 1090	Prinz	1072	Standard	1075, 1091	4Kus	2097
Marantz	1018, 1019, 1022,	Profex	1079	Stern	1091	Accurian	2220
	1078	Proline	1072	STS	1022	Advent	2169, 2201
Mark	1091	Proscan	1065	Sunkai	1074	AEG	2312
Marta	1021	Prosonic	1074, 1091	Sunstar	1072	Airis	2318
Matsui	1074, 1077	Pulsar	1032	Suntronc	1072	Aiwa	2272
Matsushita	1022	Pye	1052, 1078	Sunwood	1079, 1090	Akai	2170, 2195, 2225,
Media Center PC	1066	Quarter	1019	Superscan	1070		2227
Mediator	1078	Quasar	1022	Sylvania	1022, 1023, 1044,	Akura	2310
Medion	1074	Quelle	1072, 1078		1052, 1070	Alba	2018, 2232, 2247,
MEI	1022	Radialva	1090	Symphonic	1023, 1044, 1090		2259, 2264
Memorex	1019, 1020, 1021,	RadioShack	1021	Systemax	1066	Alco	2199
	1022, 1023, 1032,	RadioShack/Realistic	1019, 1020, 1021,	Tagar Systems	1066	Alize	2315
	1048, 1069, 1072,		1022, 1023	Taisho	1074	Allegro	2215
	1077	Radiola	1078	Tandberg	1091	Amitech	2312
Memphis	1079, 1090	Radix	1021	Tandy	1019	Amphion MediaWorks	2145
MGN Technology	1020	Randex	1021	Tashiko	1021, 1072	AMW	2145, 2313
Micromaxx	1074	RCA	1020, 1022, 1025,	Tatung	1072, 1073, 1078	Apex	2044, 2045, 2046,
Microsoft	1066		1035, 1040, 1047,	TCM	1074, 1093, 1120		2047, 2076, 2208,
Microstar	1074		1060, 1065	Teac	1023, 1091		2209
Migros	1072	Realistic	1019, 1020, 1021,	Tec	1076, 1090, 1091	Apple	2163
Mind	1066		1022, 1023	Technics	1022	Arrgo	2216
Mitsubishi	1029, 1072, 1078	ReplayTV	1041, 1068	Teknika	1021, 1022, 1023	Asono	2318
Motorola	1022	Rex	1073	Teleavia	1073	Aspire	2140, 2202
MTC	1020	RFT	1076, 1078, 1090			Astar	2162

ATACOM	2318	Enzer	2302	LG	2080, 2107, 2115,	2252, 2256, 2260,
Audiovox	2111, 2199	Epson	2165		2116, 2141, 2188,	2268, 2282, 2332,
Avious	2317	ESA	2219		2211, 2215, 2237,	2333, 2343, 2344,
Awa	2313	Finlux	2304, 2312, 2317		2239, 2285, 2293,	2345, 2367, 2371,
Axion	2171	Fintec	2299		2295, 2348, 2370	2373, 2380, 2382,
Bang & Olufsen	2210	Fisher	2212	Life	2228	2385
Baze	2317	Funai	2219	Lifetec	2228	Phonotrend 2317
BBK	2318	Gateway	2097	Limit	2305	Pioneer 2012, 2013, 2014,
Bellagio	2313	GE	2079, 2206, 2209	Liquid Video	2204	2063, 2064, 2065,
Best Buy	2309	Gericom	2269	Liteon	2097, 2121, 2220	2066, 2067, 2113,
Blaupunkt	2209	GFM	2176	Loewe	2274	2134, 2207, 2230,
Blue Parade	2207	Giec	2300	LogicLab	2305	2236, 2265, 2266,
Boghe	2300	Global Solutions	2305	Magnavox	2075, 2096, 2178,	2267, 2297, 2322,
Brainwave	2312	Global Sphere	2305		2180, 2196, 2205,	2351, 2352, 2353,
Brandt	2198, 2238	Go Video	2135, 2215		2219, 2308	2354, 2355, 2356,
Broksonic	2192, 2195	Goodmans	2247, 2289, 2298,	Magnex	2317	2357, 2358, 2359,
Bush	2018, 2060, 2248,		2300, 2308, 2330,	Majestic	2314	2377
	2264, 2301, 2308,		2369	Marantz	2282	2312
	2317, 2350, 2368	GPX	2177	Marquant	2312	Pointer 2312
California Audio Labs		Gradiente	2197	Matsui	2198, 2296	Polaroid 2047, 2133, 2185
		Graetz	2302	McIntosh	2149	Portland 2312
Cambridge Audio	2304	Greenhill	2209	Mecotek	2312	Powerpoint 2313
CAT	2306, 2307	Grundig	2271	Medion	2228	Prima 2174
CAVS	2146	Grunkel	2312, 2316	Memorex	2078, 2184, 2195	Proceed 2208
Centrum	2307	GVG	2299	MiCO	2300, 2304	Proscan 2206
CGV	2304, 2312	H&B	2308	Micromaxx	2228	Prosonic 2299, 2314
Changhong	2222	H_her	2318	Microsoft	2206	Prottron 2152
Cinetec	2313	Haaz	2304, 2305	Microstar	2228	Provision 2308
CineVision	2191, 2215	Haier	2172	Minoka	2312	Pye 2194
Clatronic	2308, 2317	Harman/Kardon	2125, 2213	Minowa	2317	Qwestar 2198
Coby	2077, 2124, 2314	HiMAX	2309	Mintek	2167, 2209	Raite 2302
Conia	2301	Hitachi	2008, 2033, 2108,	Mitsubishi	2081	RCA 2058, 2059, 2071,
Continental Edison			2302, 2309, 2320,	Mizuda	2308, 2309	2079, 2183, 2199,
			2366	Monyka	2302	2206, 2207, 2209
Crown	2312	Hiteker	2208	Mustek	2232	RedStar 2310, 2312, 2314
C-Tech	2305	Home Tech Industries		Mx Onda	2304	Regent 2203
Curtis Mathes	2217		2318	Mystral	2316	Reoc 2305
CVG	2299	Hyundai	2316	Naiko	2312	Rimax 2315
CyberHome	2048, 2068, 2216,	Ilo	2167	Nesa	2209	Rio 2215
	2233, 2258	Initial	2167, 2209	Neufunk	2302	Roadstar 2281, 2308
Cytron	2166	Innovation	2228	Nevir	2312	Ronin 2313
Daenyx	2313	Insignia	2080, 2175, 2219	Next Base	2221	Rotel 2153
Daewoo	2083, 2215, 2280,	Integra	2207	Nexxtech	2161	Rowa 2200, 2301
	2299, 2312, 2313,	Irradio	2103	NU-TEC	2301	Rowsonic 2307
	2326, 2376	iSymphony	2164	Onkyo	2205, 2290	Saba 2198, 2238
Daewoo International		JBL	2213	Oopla	2097	Sabaki 2305
		JVC	2049, 2050, 2051,	Oppo	2150, 2173	Saivod 2312
Dalton	2311		2052, 2053, 2054,	Optim	2303	Sampo 2223
Dansai	2303, 2312		2055, 2056, 2057,	Optimus	2230	Samsung 2031, 2032, 2033,
Daytek	2145, 2234, 2313		2070, 2242, 2261,	Orava	2308	2034, 2035, 2082,
Dayton	2313		2275, 2276, 2277,	Orbit	2313	2127, 2137, 2138,
DEC	2308		2278, 2339, 2340,	Orion	2027, 2060	2154, 2182, 2197,
Decca	2312		2341, 2342, 2386,	Oritron	2198, 2204	2283, 2319, 2325,
Denon	2105, 2147, 2197,		2387, 2389, 2390,	P&B	2308	2346, 2347, 2349,
	2286		2391	Pacific	2305	2372, 2381
Denver	2288, 2308, 2310,	Jwin	2148	Panasonic	2015, 2016, 2017,	Sansui 2027, 2195, 2304,
	2314	Kansai	2314		2036, 2037, 2038,	2305, 2312
Denzel	2302	Kawasaki	2199		2039, 2040, 2041,	Sanyo 2139, 2195, 2212,
Desay	2159	Kennex	2312		2042, 2043, 2074,	2374
Diamond	2304, 2305	Kenwood	2123, 2197, 2270		2089, 2104, 2108,	ScanMagic 2232
DiamondVision	2179, 2186	KeyPlug	2312		2112, 2120, 2131,	Schaub Lorenz 2312
Disney	2078, 2088	Kiïro	2312		2132, 2197, 2205,	Schneider 2226
DK Digital	2257	Kingavon	2308		2244, 2245, 2246,	Scientific Labs 2305
Dmtech	2226	Kiss	2302		2253, 2254, 2255,	Scott 2243, 2311
Dual	2302	KLH	2199, 2209		2292, 2321, 2324,	Seeltech 2318
Durabrand	2218	Koda	2308		2327, 2328, 2329,	SEG 2240, 2302, 2305,
DVX	2305	Koss	2095, 2198, 2204		2331, 2383, 2388	2313
Easy Home	2309	KXD	2309	Parasound	2151	Sharp 2009, 2010, 2084,
Eclipse	2304	Landel	2221	peeKTON	2318	2122, 2142, 2143,
E-Dem	2318	Lasonic	2214	Philips	2026, 2061, 2062,	2144, 2181, 2190,
Electrohome	2312	Lawson	2305		2075, 2090, 2094,	2228, 2262, 2375
Elin	2312	Lecson	2303		2096, 2097, 2103,	Shinsonic 2167
Elta	2263, 2312, 2315	Lenco	2308, 2312, 2317		2110, 2126, 2180,	Sigmathek 2309, 2318
Emerson	2196, 2211, 2219	Lenoxx	2203, 2218		2193, 2205, 2231,	Silva 2310
Enterprise	2211				2235, 2241, 2251,	Singer 2304, 2305
						Skymaster 2279, 2305



Skyworth	2310	Woxter	2315, 2318	Alcatel	3066	Movie Time	3031, 3063
Slim Art	2312	Xbox	2206, 2229	Americast	3046	Mr Zapp	3055
SM Electronic	2305	Xlogic	2305, 2312	Amstrad	3048, 3068	Multichoice	3057
Sonic Blue	2215	XMS	2312	Antronix	3019, 3020	Multitech	3045
Sontech	2316	Xoro	2300	Archer	3020	NEC	3018
Sony	2005, 2006, 2007, 2020, 2021, 2022, 2023, 2024, 2025, 2069, 2072, 2073, 2085, 2086, 2087, 2091, 2092, 2093, 2102, 2128, 2129, 2130, 2249, 2250, 2323, 2334, 2335, 2336, 2360, 2361, 2362, 2363, 2364, 2365, 2384	Yamada	2097, 2313, 2315	Arcon	3048	NET Brazil	3007
Soundmaster	2305	Yamaha	2000, 2001, 2002, 2003, 2011, 2018, 2019, 2036, 2106, 2197, 2273	AT&T	3013	Nokia	3051
Soundmax	2305	Yamakawa	2302, 2313	Axis	3048	Noos	3055
Spectra	2313	Yukai	2232	Bell South	3046	NSC	3031
Spectroniq	2155	Zenith	2080, 2141, 2205, 2211, 2215	Cable Vision	3014	Oak	3024
Standard	2305			Cabletenna	3019	Pace	3011, 3043, 3084
Star Cluster	2305			Cabletime	3058	Palladium	3049
Starmedia	2308, 2318			Cableview	3005	Panasonic	3034, 3036, 3040
Sungale	2158			Clearmaster	3045	Paragon	3040
Sunkai	2312			ClearMax	3045	Philips	3021, 3022, 3029, 3049, 3053, 3054, 3055
Superscan	2196			Clyde Cablevision		Pioneer	3012, 3032, 3038, 3042, 3048, 3083, 3084
Supervision	2305			Colour Voice	3022	Popular Mechanics	
Sylvania	2094, 2180, 2189, 2196, 2219, 2224			Comcast	3006, 3010, 3039	Proscan	3044
Symphonic	2062, 2180			Comcrypt	3057	Pulsar	3015, 3016 3040
Synn	2305			Comtronics	3023	PVP Stereo Visual Matrix	
T.D.E. Systems	2316			Contec	3024	Quasar	3064
Tatung	2083, 2312			Coolmax	3045	RadioShack	3040
TCM	2228, 2379			COX	3006	RCA	3041, 3045 3005, 3036, 3076, 3077
Teac	2199, 2287, 2301, 2305			Cryptovision	3060	Realistic	3020
Tec	2310			Director	3006	Recoton	3044
Technics	2197			Eastern	3025	Regal	3028
Technika	2312, 2317			Everquest	3041	Regency	3025
Telefunken	2307			Fidelity	3048	Rembrandt	3016
Tensai	2312			Filmnet	3057	Runco	3040
Tevion	2228, 2305, 2311			Filmnet Cablecrypt		Sagem	3055
Theta Digital	2207			Filmnet Comercrypt	3061	Samsung	3011, 3023, 3032, 3042
Thomson	2229, 2238, 2284, 2294			Finlux	3051	SAT	3048
Tokai	2302, 2310			Focus	3044	Scientific Atlanta	3003, 3004, 3011, 3012, 3013, 3062, 3078, 3079, 3080, 3081, 3082, 3083, 3084
Top Suxess	2318			Foxtel	3068	Signal	3026, 3041
Toshiba	2004, 2026, 2027, 2028, 2029, 2030, 2098, 2099, 2100, 2101, 2114, 2117, 2118, 2119, 2136, 2187, 2195, 2205, 2291, 2337, 2338, 2378			France Telecom	3054, 3055	Signature	3016
TRANScontinents	2313, 2317			Freebox	3069	Sony	3014, 3047
Transonic	2317			GC Electronics	3020	Sprucer	3036
Trio	2312			GE	3015, 3016	Standard Component	
Trutech	2160			GEC	3059	Starcom	3033
TruVision	2309			Gemini	3026, 3041	Stargate	3026, 3041
TSM	2318			General Instrument		Starquest	3026, 3041
Umax	2315				3006, 3008, 3016, 3039, 3050, 3067, 3075	Supercable	3008
United	2317			Goldstar	3042	Supermax	3045
Urban Concepts	2205			Gooding	3049	Tele+1	3057, 3061
US Logic	2167			Grundig	3048, 3049	Telepiu	3057
Venturer	2199			Hamlin	3027, 3028	Thomson	3000, 3009
Viewmaster	2318			Hirschmann	3051	TIME WARNER	3006
Vocopro	2156			Hitachi	3016	Tocom	3017
VocoStar	2157			HomeChoice	3056	Torx	3067
Waitec	2318			Humax	3001, 3002, 3071	Toshiba	3040
Welltech	2300			ITT Nokia	3051	Tristar	3045
Westinghouse	2109, 2168			Jasco	3041	Tudi	3052
Wharfedale	2304, 2305			Jerrold	3006, 3008, 3016, 3026, 3037, 3041, 3050, 3064, 3067, 3075	Tusa	3026, 3041
				JVC	3049	TV86	3031
				Kabel Deutschland		Unika	3019, 3020
					3043, 3073, 3074	United Cable	3037, 3064
				Macab	3055	Universal	3019, 3020
				Magnavox	3029	Universum	3049, 3051
				Maspro	3049	V2	3045
				Matsui	3049	Videoway	3065
				MegaCable	3039	View Star	3024, 3029, 3031
				Memorex	3030, 3040		
				Minerva	3049		
				Mnet	3057		
				Motorola	3006, 3008, 3010, 3013, 3039, 3072, 3075		

## Blu-ray Disc

LG	2115
Panasonic	2089, 2131, 2132
Pioneer	2134
Samsung	2035, 2127
Sharp	2142, 2143, 2144
Sony	2025
Yamaha	2018

## DVR

Bush	2060
Panasonic	2037, 2038, 2039, 2040, 2041, 2042
Philips	2061, 2062
Pioneer	2063, 2064, 2065, 2066, 2067
RCA	2059
Samsung	2035
Yamaha	2036

## DVD Recorder

Aspire	2140
Astar	2162
Broksonic	2192
Go Video	2135
Hitachi	2108
Insignia	2080
Irradio	2103
JVC	2054, 2055, 2056, 2057
LG	2107, 2115, 2141, 2188
Liteon	2121
Panasonic	2037, 2038, 2039, 2041, 2042, 2043, 2089, 2104, 2108, 2112
Philips	2090, 2096, 2097, 2126, 2193
Pioneer	2067, 2113
Pye	2194
Samsung	2034, 2082, 2138
Sansui	2027
Sanyo	2139
Sony	2022, 2023, 2024, 2085, 2086, 2087, 2102, 2128, 2129, 2130
Sylvania	2189
Toshiba	2030, 2099, 2100, 2101, 2114, 2117, 2118, 2119
Yamaha	2106

## Cable

ABC	3004, 3015, 3016, 3017, 3037, 3040, 3067, 3080, 3081
ADB	3070
Adelphia	3003

Viewmaster	3045	Condor	4074, 4090, 4137	Fuba	4074, 4083, 4090, 4092, 4093, 4101, 4133	Lasat	4074, 4088, 4090, 4100, 4133, 4134, 4137
Vision	3045	Connexions	4074, 4092	Galaxis	4074, 4087, 4090, 4091, 4096, 4098, 4133, 4140	Lasonic	4062
Visiopass	3051, 3054, 3055	Conrad	4074, 4133, 4136, 4137	GE	4015, 4016, 4061, 4151	Lenco	4074, 4083, 4099, 4133, 4137, 4139
Vortex View	3045	Conrad Electronic	4137, 4139	General Instrument	4027, 4065	Leng	4095
Wittenberg	3048	Contec	4096	GMI	4089	Lennox	4098
Zenith	3035, 3040, 3046	Coolsat	4050	GOI	4039	Lenson	4136
Zentek	3044	Cosat	4098	Goldbox	4135	Lexus	4103
<b>Sattelite</b>							
AB Sat	4138, 4139	Coship	4063	GoldStar	4099	LG	4053, 4057, 4099
AccessHD	4058	Crown	4089	Goodmans	4079, 4080, 4084	Lifesat	4074, 4090, 4134, 4139
ADB	4142	Daeryung	4092	Goodmind	4061	Lifetec	4090
AGS	4138	Daewoo	4107, 4139	Grandin	4077	Lorenzen	4137
Akai	4101, 4103	DDC	4085	Grundig	4083, 4099	Lorraine	4099
Alba	4083, 4084, 4085, 4086, 4108, 4139	Delega	4085	Grothusen	4083, 4099	Lupus	4074, 4090
Aldes	4085, 4087, 4088	Dew	4096	Grundig	4084, 4086, 4093, 4113, 4129, 4136, 4140	Luxor	4136
Allsat	4098, 4101, 4103	Diamond	4097	Hänsel & Gretel	4137	Lyonnaise	4102
Allsonic	4074, 4087, 4090	Digiality	4137	Hantor	4083, 4095	Macab	4102
Alltech	4139	Digital Stream	4059	Hanuri	4088	Magnavox	4045, 4055
Alpha	4103	DIRECTV	4017, 4018, 4020, 4021, 4022, 4024, 4037, 4038, 4040, 4041, 4043, 4045, 4057, 4106, 4143, 4144, 4145, 4146, 4147, 4148, 4149, 4150, 4151, 4152, 4153, 4154, 4155, 4156, 4157	Happauge	4126	Manata	4077, 4138, 4139
Alpha Digital	4058	Discoverer	4134	Heliocom	4137	Manhattan	4084, 4088, 4098, 4138
Alphastar	4031	Discovery	4138	Hinari	4085	Marantz	4101
Amitronica	4139	Diseqc	4138	Hirschmann	4074, 4093, 4128, 4136, 4137, 4138	Mascom	4088
Amstrad	4089, 4113, 4136, 4139	Dish Network	4011, 4012, 4013, 4014, 4019, 4039, 4064	Hisawa	4095	Maspro	4084, 4139
Anglo	4139	Dishpro	4039, 4064	Hisense	4066	Matsui	4138
Ankaro	4074, 4087, 4090, 4139	Distrisat	4103	Hitachi	4032, 4084, 4149, 4153	Max	4137
Antron	4083, 4086	Ditristrad	4098	Homecast	4005, 4006, 4007	Mediabox	4135
Apollo	4083	DNT	4092, 4101, 4103	Houston	4098	Mediamarkt	4089
Armstrong	4089, 4103	Drake	4026	HTS	4039	Mediasat	4091, 4135, 4136
Artec	4054	DStv	4140	Hughes	4018, 4022, 4144, 4146, 4150, 4152	Medion	4074, 4090, 4139
Asat	4101, 4103	Dune	4074	Hughes Network Systems	4021	Medison	4139
ASLF	4139	Echostar	4011, 4019, 4039, 4064, 4092, 4139	Humax	4051, 4075, 4076, 4110	Mega	4101, 4103
Astacom	4138	Einhell	4083, 4087, 4089, 4136, 4139	Huth	4087, 4089, 4094, 4095, 4096, 4098, 4137, 4141	Memorex	4045
Astra	4089, 4091, 4100, 4137, 4139	Elap	4138, 4139	Hypson	4077	Metronic	4077, 4078, 4083, 4086, 4087, 4088, 4139
Astro	4074, 4086, 4088, 4090, 4093, 4135, 4136, 4137	Elekta	4088	Ilo	4066	Metz	4093
AudioTon	4086, 4098	Elsat	4139	Imex	4077	Micro electronic	4136, 4137, 4139
Aurora	4140	Elta	4074, 4083, 4090, 4098, 4101, 4103	Innovation	4090	Micro Technology	4139
Austar	4140	Emanon	4083	Insignia	4057	MicroGem	4056
Axiel	4138	Emme Esse	4074, 4090	Intertronic	4089	Micromaxx	4074, 4090
Axis	4074, 4090, 4091, 4096	Engel	4139	Intervision	4098, 4137	Microstar	4090
Best	4074, 4090	Ep Sat	4084	ITT Nokia	4084	Microtec	4139
Blaupunkt	4093	EURIEULT	4077	Jerrold	4065	Minerva	4093
Blue Sky	4139	Eurodec	4102	Johansson	4095	Mitsubishi	4084, 4093, 4152
Boca	4089, 4100, 4105, 4139	Europa	4103, 4136, 4137	JOK	4138	Mitsumi	4100
Boston	4138	Europhon	4137	JSR	4098	Morgan's	4089, 4100, 4101, 4103, 4139
Brain Wave	4095	Eurosat	4089	JVC	4011, 4019, 4039, 4079	Motorola	4008, 4009, 4010, 4065
Broadcast	4094	Eurosky	4074, 4089, 4090, 4133, 4136, 4137	Kamm	4139	Multichoice	4140
Broco	4139	Eurostar	4089, 4133, 4137	Kathrein	4093, 4101, 4103, 4109, 4112, 4120, 4133, 4138, 4139	Multitec	4134
BSkyB	4113, 4123	Eutelsat	4139	Klap	4138	Muratto	4099
BT	4138	Exator	4083, 4086	Konig	4137	Mysat	4139
Bubu Sat	4139	Expressvu	4039	Kosmos	4099	Navex	4095
Bush	4084, 4127	Fenner	4074, 4134, 4139	KR	4086	Neuhaus	4091, 4098, 4136, 4137, 4139
Cambridge	4136	Ferguson	4084, 4102, 4132	Kreiselmeyer	4093	Neusat	4139
Canal Satellite	4135	Fidelity	4136	K-SAT	4139	Next Level	4065
Canal+	4135	Finlandia	4084	Kyostar	4083	NextWave	4141
CaptiveWorks	4049	Finlux	4084	L&S Electronic	4074	Nikko	4089, 4139
Channel Master	4060, 4085	FinnSat	4096, 4102			Nokia	4084, 4122
Chaparral	4025	Flair Mate	4139			Nordmende	4083, 4084, 4085, 4088, 4102
CHEROKEE	4138	Foxtel	4140			Nova	4140
Chess	4134, 4139	Freecom	4083, 4099, 4136			Novis	4095
CityCom	4084, 4133, 4137	FTEmaximal	4074, 4139			Oceanic	4097
Clatronic	4095					Octagon	4083, 4086, 4096
CNT	4088					Okano	4089
Comag	4000, 4001, 4002, 4003, 4004					Optex	4098
Commlink	4087					Optus	4135, 4140, 4141
Comtech	4096						

Orbitech	4083, 4134, 4135, 4136	Satcom	4094, 4137	Tivax	4058
OSat	4086	Satec	4139	Tivo	4150
Otto Versand	4093	Satelco	4074	Tokai	4103
Pace	4084, 4093, 4113, 4121, 4125, 4138	Satford	4094	Tonna	4084, 4094, 4098, 4136, 4139
Pacific	4097	Satmaster	4094	Toshiba	4144, 4152, 4153
Packsat	4138	Satplus	4134	Triad	4099
Palcom	4085	Schneider	4090, 4134, 4138	Triasat	4136
Palladium	4089, 4136	Schwaiger	4097, 4134, 4137	Triax	4093, 4133, 4136, 4139
Palsat	4134, 4136	SCS	4133	Turnsat	4139
Panasat	4140	Seemann	4089, 4091, 4092	Tvronics	4132
Panasonic	4043, 4044, 4046, 4084, 4113, 4118, 4143, 4148	SEG	4074, 4083, 4090, 4095	Twiner	4077, 4139
Panda	4084, 4137	Seleco	4098	UEC	4140
Pansat	4047	Servi Sat	4077, 4139	Uher	4134
Patriot	4138	Siemens	4093	UltimateTV	4020
Paysat	4045	Silva	4099	Uniden	4029, 4045
PCT	4060	Skantin	4139	Unisat	4089, 4096, 4103
Philco	4055	Skardin	4091	Unitor	4095
Philips	4021, 4022, 4045, 4084, 4101, 4103, 4111, 4115, 4135, 4138, 4150, 4152, 4153, 4155, 4156	Skinsat	4136	Universum	4093, 4133, 4137
Phoenix	4096	SKR	4139	US Digital	4066
Phonotrend	4084, 4087, 4098	Skymaster	4067, 4068, 4087, 4134, 4139	Variosat	4093
Pioneer	4124, 4135	Skymax	4101, 4103	Vega	4074
Polsat	4102	SkySat	4134, 4136, 4137, 4139	Ventana	4101, 4103
Predki	4095	Skyvision	4098	Viewsat	4048
Premiere	4098, 4135	SM Electronic	4134, 4139	Visiosat	4095, 4098, 4138, 4139
Priesner	4089	Smart	4133, 4139	Voom	4065
Primestar	4030	Sony	4017, 4020, 4135	Vortec	4083
Profile	4138	SR	4089, 4100	Welltech	4134
Promax	4084	Star Choice	4065	WeTeKom	4134, 4136
Prosat	4085, 4087	Starland	4139	Wevasat	4084
Proscan	4015, 4016, 4040, 4151	Starring	4095	Wewa	4084
Protek	4097	Start Trak	4083	Winersat	4095
Proton	4066	Strong	4074, 4083, 4086, 4090, 4099, 4140	Wisi	4084, 4092, 4093, 4136, 4137
Provision	4088	STS	4033	Woorisat	4088
Quadral	4074, 4085, 4087, 4090, 4138	STVI	4077	Worldsat	4138
Quelle	4093, 4133, 4137	Sumida	4089	Xrypton	4074
Quiero	4102	Sunny Sound	4074	XSat	4139
RadioShack	4065	Sunsat	4139	Zehnder	4074, 4088, 4090, 4131, 4133
Radiola	4101, 4103	Sunstar	4074, 4089, 4100	Zenith	4052, 4057, 4145
Radix	4092, 4119	Supermax	4141	Zodiac	4086
Rainbow	4086	Tandberg	4102		
RCA	4015, 4016, 4034, 4035, 4036, 4037, 4038, 4040, 4151, 4157	Tandy	4086		
Realistic	4028	Tantec	4084		
Redpoint	4091	TCM	4090		
Redstar	4074, 4090	Techniland	4094		
RFT	4087, 4101, 4103	TechniSat	4071, 4072, 4073, 4092, 4103, 4116, 4117, 4134, 4135, 4136		
Roadstar	4139	Technology	4140		
Roch	4077	Technosat	4141		
Rover	4074, 4139	Technowelt	4137		
Saba	4088, 4133, 4137, 4138	Teco	4089, 4100		
Sabre	4084	Telanor	4085		
Sagem	4069, 4102	Telasat	4133, 4137		
Sakura	4096	Telecom	4139		
Samsung	4018, 4021, 4023, 4041, 4042, 4081, 4082, 4083, 4114, 4150, 4154	Telefunken	4067, 4083, 4138		
SAT	4085, 4136	Teleka	4086, 4089, 4092, 4136, 4137		
Sat Cruiser	4141	Telemaster	4088		
Sat Partner	4083, 4086, 4088, 4095, 4099, 4136	Telesat	4137		
Sat Team	4139	Telestar	4134, 4135, 4136		
		Televess	4084, 4136		
		Telewire	4098		
		Tempo	4141		
		Tevion	4090, 4139		
		Thomson	4070, 4084, 4102, 4104, 4130, 4133, 4135, 4137, 4138, 4139		
		Thorens	4097		
		Thorn	4084		

---

## CD

Yamaha 5000, 5013

---

## CD Recoder

Yamaha 5001

---

## MD

Yamaha 5002, 5003, 5004

---

## Tape

Yamaha 5005, 5006

---

## Tuner

Yamaha 5007, 5008, 5009,  
5010, 5014, 5015,  
5016, 5017, 5018

---

## USB

Yamaha 5012, 5021

---

## DOCK

Yamaha 5011, 5022

---

## LD

Yamaha 2002



*Thank you for selecting a YAMAHA speaker system.*

## PRECAUTIONS

Read these precautions carefully before using your speakers.

- To assure the finest performance, please read this manual carefully. Keep it in a safe place for future reference.
- Install the speaker in a cool, dry, clean place - away from windows, heat sources, sources of excessive vibration, dust, moisture and cold. Avoid sources of humming (transformers, motors). To prevent fire or electrical shock, do not expose the speaker to rain or water.
- To prevent the enclosure from warping or discoloring, do not place the speaker where it will be exposed to direct sunlight or excessive humidity.
- Do not place the following objects on the speaker: Glass, china, small metallic, etc.  
 If glass etc. falls by vibrations and breaks, it may cause bodily injury.  
 A burning candle etc.  
 If the candle falls by vibrations, it may cause fire and bodily injury.  
 A vessel with water in it  
 If the vessel falls by vibrations and water spills, it may cause damage to the speaker, and/or you may get an electric shock.
- Do not place the speaker where foreign objects such as water drips might fall. It might cause a fire, damage to the speaker, and/or bodily injury.
- Do not place the speaker where it is liable to be knocked over or struck by falling objects. Stable placement will also ensure better sound performance.
- Placing the speaker on the same shelf or rack as the turntable can result in feedback.
- Never put a hand or a foreign object into the port located on the rear of the speaker as this might cause bodily injury and/or damage to the speaker.
- When moving the speaker, do not hold the port as it might cause bodily injury and/or damage to the speaker.
- Any time you note distortion, reduce the volume control on your amplifier to a lower setting. Never allow your amplifier to be driven into "clipping". Otherwise the speaker may be damaged.
- When using an amplifier with a rated output power higher than the nominal input power of the speaker, care should be taken never to exceed the speaker's maximum input.
- Do not attempt to clean the speaker with chemical solvents as this might damage the finish. Use a clean, dry cloth.

- Do not attempt to modify or fix the speaker. Contact qualified YAMAHA service personnel when any service is needed. The cabinet should never be opened for any reasons.
- **Secure placement or installation is the owner's responsibility. YAMAHA shall not be liable for any accident caused by improper placement or installation of speaker.**

## PRECAUTIONS WHEN POSITIONING THE SPEAKERS

The speaker is constructed with the majority of the weight located in its upper portion, and is thus susceptible to falling over if proper care is not taken to insure its stability. If the speaker falls over, it may damage the speaker or be the cause of injury (or even death) to persons and/or damage to personal property.

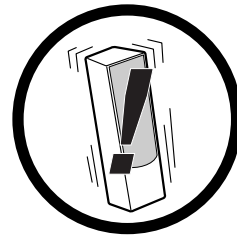

### For safe and proper use of the speaker:

- Position the speaker in a location that is solid, level, smooth, and low (with respect to the floor).
- Do not push or apply pressure to the side of the speaker when moving, or lean objects against the side of the speaker.
- Do not sit on or set objects on top of the speaker.

Vibrations or jolts associated with earthquakes and other phenomena or activities may cause the speaker to fall over.

For safety reasons, using commercially available products that increase stability in the speaker is recommended (metal fittings or chains, etc.).

### Use the stands included with the speaker to increase stability:

Be sure to use the stands regardless of where the speaker is positioned. Attaching the stands included with the speaker reinforces the base of the speaker not to fall over.

Please be cautioned that even though the stands are connected, this does not guarantee that the speaker will not fall over.

## ATTACHING THE STANDS

When placing the speakers, be sure to use the stands to increase stability.

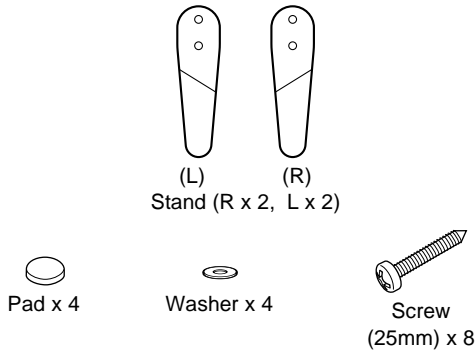

### Note

The provided stands are in two types. Two stands are for the right side and others are for the left side. Attach each stand to the proper position on the bottom of the speaker by following the figure below.

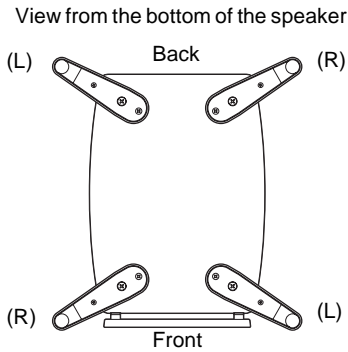

Use the 8 specified holes located on the base of the speaker.

### Procedure:

- ① First, put the screw through the washer, then through the inner hole of the stand, and screw it into the outside hole of the speaker. Do not tighten too much at this point.

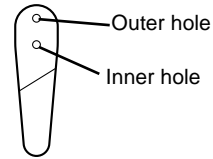

- ② Put a screw through the outer hole on the stand, and screw it into the other hole on the base of the speaker.
- ③ Tighten both of the screws firmly.
- ④ Attach a pad to the bottom of the end portion of the stand.
- ⑤ Attach the other stands to the other corners of the base of the speaker in the same way and confirm that all 4 stands have been firmly attached.

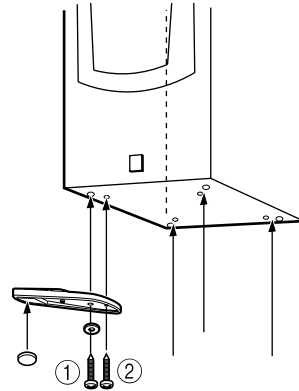

### Note

Be careful not to apply force to the side of the speaker, otherwise the speaker may fall causing damage to the speaker or personal injury.

## CONNECTIONS TO YOUR AMPLIFIER

This speaker system is capable of standard connections and bi-wired connections. Before making connections, make sure that the amplifier is switched off.

### [Standard Connection]

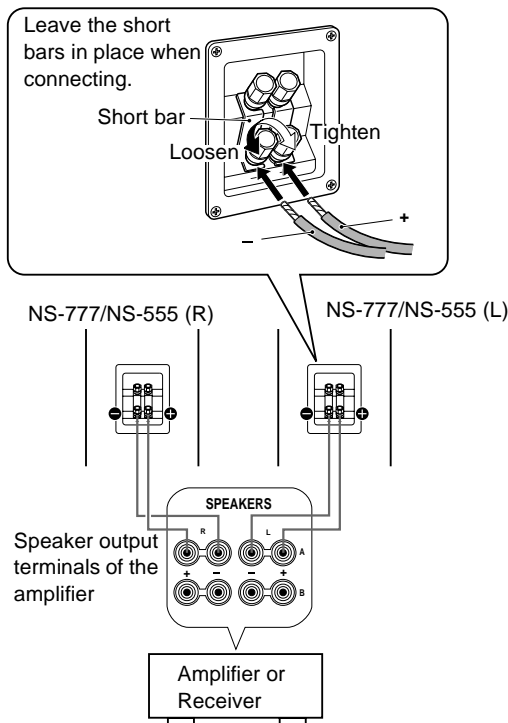

### How to Connect:

- 1 Remove the insulation coating at the extremity of each speaker cable by twisting the coating off.

**Good**   **No Good**



- 2 Loosen the terminal knob.
- 3 Insert the bare wire.
- 4 Tighten the knob and secure the cable. Test the firmness of the connection by pulling lightly on the cable at the terminal.

### Note

Do not let the bare speaker wires touch each other to avoid damaging the speaker or the amplifier, or both of them.

### Using a Banana Plug

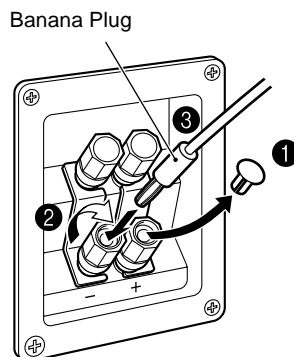

- 1 Remove the speaker terminal cover by gently pulling it toward you.
- 2 Tighten the terminal knob.
- 3 Simply insert the banana plug into the terminal.

### CONNECTIONS

- Connect the screw-type input terminals at the rear of the speaker to the speaker output terminals of the amplifier (or receiver) with the speaker cable.
- Connect the (+) terminals on the amplifier (or receiver) and the speaker using one side of the cable. Connect the (-) terminals on both components using the other side of the cable.
- Connect one speaker to the left (marked L) terminals of your amplifier, and another speaker to the right (marked R) terminals, making sure not to reverse the polarity (+, -). If one speaker is connected with reversed polarity, the sound will be unnatural and lack bass.

## [Bi-Wired Connection]

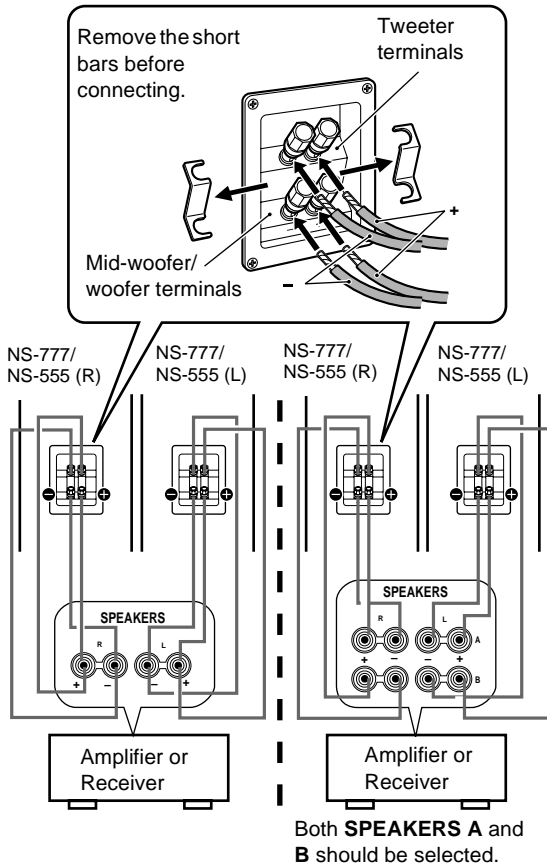

This speaker system is capable of bi-wired connections. To connect the speaker to the output terminals of the amplifier (or receiver), two pairs of cables for each of mid-woofer/woofer and tweeter used instead of standard connections.

This type of connection decreases the modulation distortion caused by electric resistance of the cables and driving current of the speakers. Consequently, purer sound quality can be expected.

To utilize bi-wired connections, remove the short bars from the terminals first, and then connect the mid-woofer/woofer and tweeter to the amplifier separately using two pairs of cables.

## PLACING THE SPEAKERS

Place the speakers on a sturdy, vibration-free surface, on a well-built stand.

### ■ Using as 2ch stereo speakers

Better stereo images will be obtained when the speakers are slightly angled in towards the listeners.

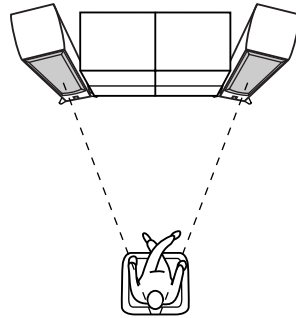

### ■ Using as main speakers in a multi channel system

Position the speakers on both sides of the TV. The positioning of speakers is important, because it controls the whole sound quality of a multi channel system. Set up the speakers on the basis of your listening position by following the owner's manual supplied with your amplifier.

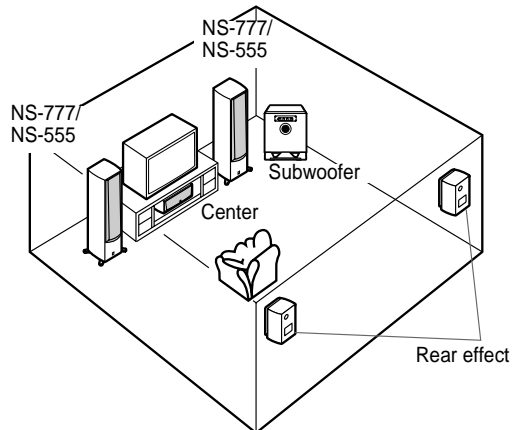

### Note

This speaker features a magnetically shielded design, but there is still a chance that placing it too close to a TV set might impair picture color. Should this happen, move the speaker away from the TV set.



## REMOVING THE FRONT COVER

The front cover is fastened to the enclosure at six points and can be removed if desired. To remove the cover, hold on to both sides and slowly pull straight away from the speaker. To reattach, line up the six pegs on the inside surface of the cover with the six corresponding holes on the speaker and push gently.

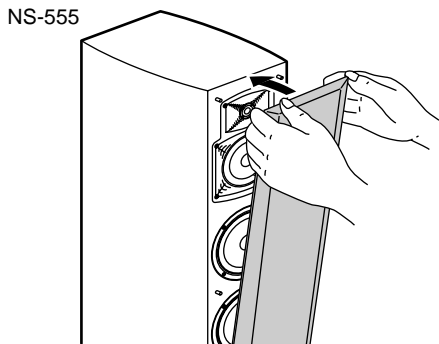
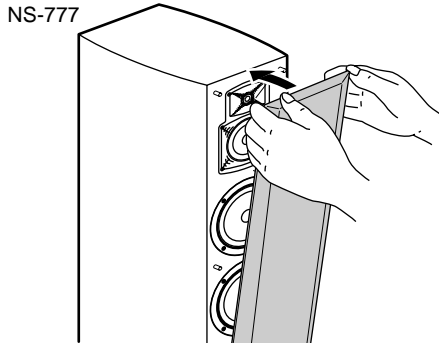

### Note

When the cover is removed, take care not to touch the speaker units with your hands or to exert excessive force with tools.

## SPECIFICATIONS

### NS-777

Type .....	3-way bass reflex speaker system Magnetic shielding type
Driver .....	20 cm (8") cone woofer x 2 Wave guide horn 13 cm (5") cone mid-range Wave guide horn 2.5 cm (1") dome tweeter
Frequency response.....	30 Hz – 35 kHz
Nominal impedance .....	6 ohms
Nominal input power .....	100 W
Maximum input power .....	250 W
Sensitivity .....	89 dB/2.83 V/m
Crossover frequency .....	1 kHz, 4 kHz
Dimensions (W x H x D)	276 mm x 1100 mm x 390 mm (10.9" x 43.3" x 15.4")
Weight.....	24.4 kg (53 lbs. 13 oz.)
Accessories .....	Stand (R x 2, L x 2) Washer x 4 Screw x 8 Pad x 4

### NS-555

Type .....	3-way bass reflex speaker system Magnetic shielding type
Driver .....	16 cm (6.5") cone woofer x 2 Wave guide horn 13 cm (5") cone mid-range Wave guide horn 2.5 cm (1") dome tweeter
Frequency response.....	35 Hz – 35 kHz
Nominal impedance .....	6 ohms
Nominal input power .....	100 W
Maximum input power .....	250 W
Sensitivity .....	88 dB/2.83 V/m
Crossover frequency .....	1 kHz, 4 kHz
Dimensions (W x H x D) ...	222 mm x 980 mm x 345 mm (8.74" x 38.6" x 13.6")
Weight.....	20 kg (44.1 lbs)
Accessories .....	Stand (R x 2, L x 2) Washer x 4 Screw x 8 Pad x 4

- Specifications subject to change without notice due to product improvements.
- Care should be taken not to exceed the input power values noted above.

## 卸下前盖

前盖四周六点被扣紧, 可根据需要卸下。卸下前盖时, 握住两边从扬声器慢慢直拉出来。如需再安装, 将前盖里层的六个钉对准扬声器六个相应的孔, 轻轻推入。

NS-777

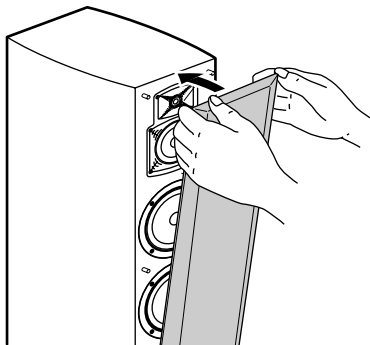

NS-555

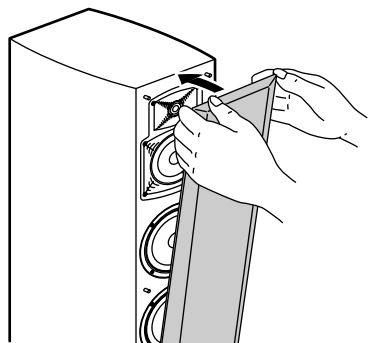

### 注意

当前盖被卸下后, 切勿用手接触扬声器或用工具过分施力。

## 规格

### NS-777

种类	3 声道低频反射式扬声器系统
	磁屏型
驱动器	20 cm 圆锥低音扬声器 × 2 波导喇叭 13 cm 圆锥中型 波导喇叭 2.5 cm 穹型低音扬声器
频率响应	30 Hz 至 35 kHz
额定阻抗	6 欧姆
额定输入功率	100 W
最大输入功率	250 W
灵敏度	.89 dB/2.83 V/m
交换频率	1 kHz, 4 kHz
尺寸 (宽 × 高 × 深)	276 mm × 1100 mm × 390 mm
重量	24.4 kg
附件	支架 (右 × 2, 左 × 2) 垫圈 × 4 螺丝 × 8 防滑垫 × 4

### NS-555

种类	3 声道低频反射式扬声器系统
	磁屏型
驱动器	16 cm 圆锥低音扬声器 × 2 波导喇叭 13 cm 圆锥中型 波导喇叭 2.5 cm 穹型低音扬声器
频率响应	35 Hz 至 35 kHz
额定阻抗	6 欧姆
额定输入功率	100 W
最大输入功率	250 W
灵敏度	.88 dB/2.83 V/m
交换频率	1 kHz, 4 kHz
尺寸 (宽 × 高 × 深)	222 mm × 980 mm × 345 mm
重量	20 kg
附件	支架 (右 × 2, 左 × 2) 垫圈 × 4 螺丝 × 8 防滑垫 × 4

- 产品规格若有变动, 恕不另行通知。
- 请注意输入功率值不要超过上述值。



Thank you for selecting a YAMAHA speaker system.

### PRECAUTIONS

Read these precautions carefully before using your speaker.

- To assure the finest performance, please read this manual carefully. Keep it in a safe place for future reference.
- Install the speaker in a cool, dry, clean place - away from windows, heat sources, sources of excessive vibration, dust, moisture and cold. Avoid sources of humming (transformers, motors). To prevent fire or electrical shock, do not expose the speaker to rain or water.
- To prevent the enclosure from warping or discoloring, do not place the speaker where it will be exposed to direct sunlight or excessive humidity.
- Do not place the following objects on the speaker: Glass, china, small metallic, etc.  
If glass etc. falls by vibrations and breaks, it may cause bodily injury.  
A burning candle etc.  
If the candle falls by vibrations, it may cause fire and bodily injury.  
A vessel with water in it  
If the vessel falls by vibrations and water spills, it may cause damage to the speaker, and/or you may get an electric shock.
- Do not place the speaker where foreign objects such as water drips might fall. It might cause a fire, damage to the speaker, and/or bodily injury.
- Do not place the speaker where it is liable to be knocked over or struck by falling objects. Stable placement will also ensure better sound performance.
- Placing the speaker on the same shelf or rack as the turntable can result in feedback.
- Any time you note distortion, reduce the volume control on your amplifier to a lower setting. Never allow your amplifier to be driven into "clipping". Otherwise the speaker may be damaged.
- When using an amplifier with a rated output power higher than the nominal input power of the speaker, care should be taken never to exceed the speaker's maximum input.
- Do not attempt to clean the speaker with chemical solvents as this might damage the finish. Use a clean, dry cloth.
- Do not attempt to modify or fix the speaker. Contact qualified YAMAHA service personnel when any service is needed. The cabinet should never be opened for any reasons.
- **Secure placement or installation is the owner's responsibility. YAMAHA shall not be liable for any accident caused by improper placement or installation of speaker.**

### PLACING THE SPEAKER

Place the speaker on TV whose top is flat or on the floor under the TV or inside the TV rack so that it is stabilized. When placing the speaker on top of the TV, to prevent the speaker from falling down, put the provided fasteners at four points on the bottom of the speaker and the top of the TV.

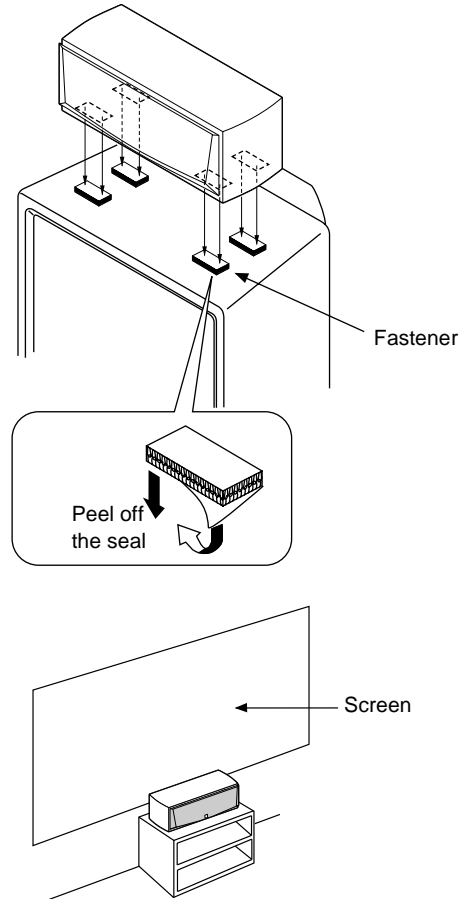

#### Note

- Do not place the speaker on top of the TV whose area is smaller than the bottom area of the speaker. If placed, the speaker may drop out causing an injury to you.
- Do not place the speaker on top of the TV with an inclination.
- Do not touch the adhesive surface after peeling off the seal as this will weaken its adhesive strength.
- Thoroughly wipe clean the surface where the fastener is to be applied. Note that adhesive strength is weakened if the surface is dirty, oily or wet and that this may cause the center speaker to drop.
- This speaker features a magnetically shielded design, but there is still a chance that placing it too close to a TV set might impair picture color. Should this happen, move the speaker away from the TV set.

## CONNECTIONS TO YOUR AMPLIFIER

Before making connections, make sure that the amplifier is switched off.

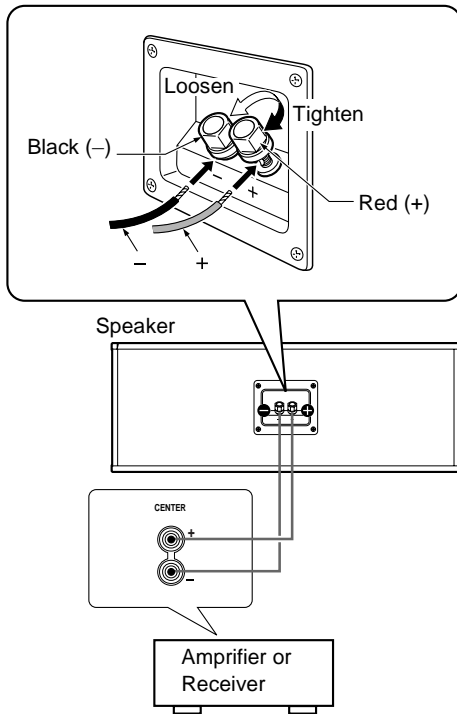

### CONNECTIONS

- Connect the screw-type input terminals at the rear of the speaker to the speaker output terminals of the amplifier (or receiver) with the speaker cable.
- Connect the (+) terminals on the amplifier (or receiver) and the speaker using one side of the cable. Connect the (-) terminals on both components using the other side of the cable.
- Connect the speaker to the center terminals of the amplifier (or receiver) making sure not to reverse the polarity (+, -). If the speaker is connected with reversed polarity, the sound will be unnatural and lack bass.

#### How to Connect:

- ① Remove the insulation coating at the extremity of each speaker cable by twisting the coating off.

**Good**   **No Good**



- ② Loosen the terminal knob.
- ③ Insert the bare wire.
- ④ Tighten the knob and secure the cable. Test the firmness of the connection by pulling lightly on the cable at the terminal.

#### Note

Do not let the bare speaker wires touch each other to avoid damaging the speaker or the amplifier, or both of them.

#### [Using a Banana Plug]

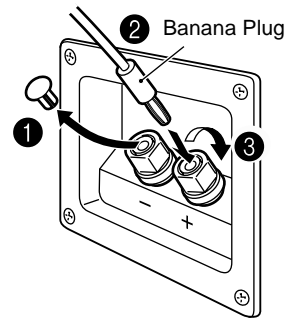

- ① Remove the speaker terminal cover by gently pulling it toward you.
- ② Tighten the terminal knob.
- ③ Simply insert the banana plug into the terminal.

## REMOVING THE FRONT COVER

The front cover is fastened to the enclosure at four points and can be removed if desired. To remove the cover, hold on to both sides and slowly pull straight away from the speaker. To reattach, line up the four pegs on the inside surface of the cover with the four corresponding holes on the speaker and push gently.

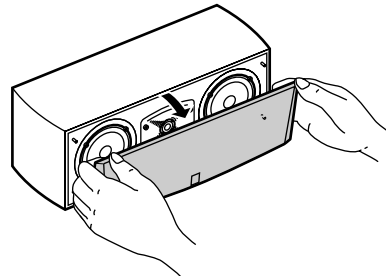

#### Note

When the cover is removed, take care not to touch the speaker units with your hands or to exert excessive force with tools.

## SPECIFICATIONS

Type..... 2-way acoustic suspension speaker system  
magnetic shielding type  
Driver..... 13 cm (5") cone woofer x 2  
2.5 cm (1") dome tweeter  
Frequency response ..... 55 Hz – 35 kHz  
Nominal impedance..... 6 ohms  
Nominal input power..... 100 W  
Maximum input power ..... 250 W  
Sensitivity ..... 89 dB/2.83 V/m  
Crossover frequency..... 3 kHz  
Dimensions (W x H x D)... 514 mm x 190 mm x 213 mm  
(20.2"x 7.5" x 8.4")  
Weight ..... 7.3 kg (16 lbs. 1 oz.)  
Accessories ..... Fastener x 4

- Specifications subject to change without notice due to product improvements.
- Care should be taken not to exceed the input power values noted above.

## 规格

种类 .....	2 声道声学支撑扬声器系统 磁屏型
驱动器 .....	13 cm 圆锥低音扬声器 × 2 2.5 cm 穹型高频扬声器
频率响应 .....	55 Hz 至 35 kHz
额定阻抗 .....	6 欧姆
额定输入功率 .....	100 W
最大输入功率 .....	250 W
敏感度 .....	89 dB/2.83 V/m
交换频率 .....	3 kHz
尺寸 (宽 × 高 × 深) .....	514 mm × 190 mm × 213 mm
重量 .....	7.3kg
附件 .....	固定物 × 4

- 产品规格若有变动，恕不另行通知。
- 请注意输入功率值不要超过上述值。



Thank you for selecting a YAMAHA speaker system.

## PRECAUTIONS

Read these precautions carefully before using your speakers.

- To assure the finest performance, please read this manual carefully. Keep it in a safe place for future reference.
- Install the speakers in a cool, dry, clean place - away from windows, heat sources, sources of excessive vibration, dust, moisture and cold. Avoid sources of humming (transformers, motors). To prevent fire or electrical shock, do not expose the speakers to rain or water.
- To prevent the enclosure from warping or discoloring, do not place the speakers where they will be exposed to direct sunlight or excessive humidity.
- Do not place the following objects on the speakers: Glass, china, small metallic, etc.  
If glass etc. falls by vibrations and breaks, it may cause bodily injury.

A burning candle etc.

If the candle falls by vibrations, it may cause fire and bodily injury.

A vessel with water in it

If the vessel falls by vibrations and water spills, it may cause damage to the speakers, and/or you may get an electric shock.

- Do not place the speakers where foreign objects such as water drips might fall. It might cause a fire, damage to the speakers, and/or bodily injury.
- Do not place the speakers where they are liable to be knocked over or struck by falling objects. Stable placement will also ensure better sound performance.
- Placing the speakers on the same shelf or rack as the turntable can result in feedback.
- Any time you note distortion, reduce the volume control on your amplifier to a lower setting. Never allow your amplifier to be driven into "clipping". Otherwise the speakers may be damaged.
- When using an amplifier with a rated output power higher than the nominal input power of the speakers, care should be taken never to exceed the speakers' maximum input.
- Do not attempt to clean the speakers with chemical solvents as this might damage the finish. Use a clean, dry cloth.
- Do not attempt to modify or fix the speakers. Contact qualified YAMAHA service personnel when any service is needed. The cabinet should never be opened for any reasons.
- **Secure placement or installation is the owner's responsibility. YAMAHA shall not be liable for any accident caused by improper placement or installation of speakers.**

## PLACING THE SPEAKERS

Place the speakers on a sturdy, vibration-free surface, on a well-built stand.

### ■ Using as 2ch stereo speakers

Better stereo images will be obtained when the speakers are slightly angled in towards the listeners.

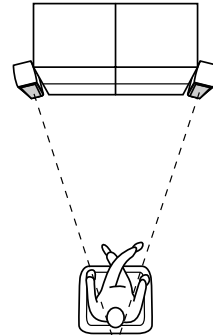

### ■ Using as main speakers in a multi channel system

Position the speakers on both sides of the TV. The positioning of speakers is important, because it controls the whole sound quality of a multi channel system. Set up the speakers on the basis of your listening position by following the owner's manual supplied with your amplifier.

### ■ Using as front or rear effect speakers

Mount the speakers on a wall or place the speakers on a shelf. Determine the best position by following the owner's manual supplied with your amplifier.

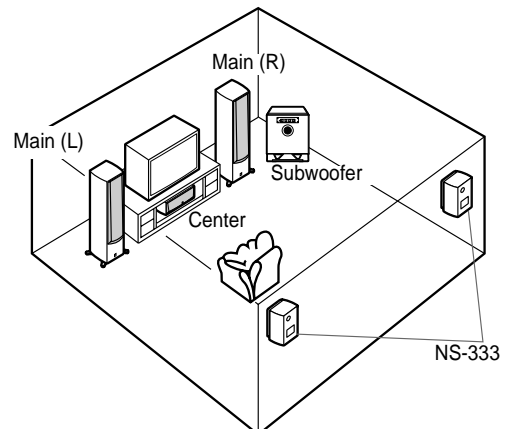

#### Note

This speaker features a magnetically shielded design, but there is still a chance that placing it too close to a TV set might impair picture color. Should this happen, move the speaker away from the TV set.

## ■ To mount the speaker on a wall by using the attached mounting bracket

Fasten screws into a firm wall or wall support as shown in the figure, and hang the holes of the mounting bracket on the protruding screws.

- \* Make sure that the screws are securely caught by the narrow parts of the holes.

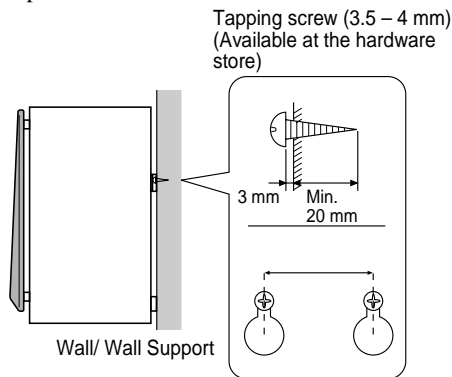

### WARNING

- This speaker weighs 5.5 kg (12 lbs. 2 oz.). Do not mount it on thin plywood or a wall with soft surface material. If mounted, the screws may come out of the flimsy surface and the speaker may fall. This damages the speaker or causes personal injury.
- Do not install the speaker to a wall with nails, adhesives, or any other unstable hardware. Long-term use and vibrations may cause it to fall.
- To avoid accidents resulting from tripping over loose speaker cable, fix it to the wall.

## CONNECTIONS TO YOUR AMPLIFIER

Before making connections, make sure that the amplifier is switched off.

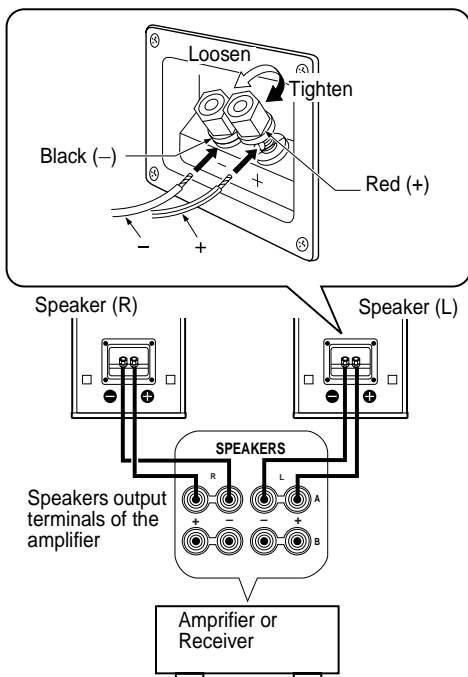

## Connections

- Connect the screw-type input terminals at the rear of the speaker to the speaker output terminals of the amplifier (or receiver) with the speaker cable.
- Connect the (+) terminals on the amplifier (or receiver) and the speaker using one side of the cable. Connect the (-) terminals on both components using the other side of the cable.
- Connect the speaker to the center terminals of the amplifier (or receiver) making sure not to reverse the polarity (+, -). If the speaker is connected with reversed polarity, the sound will be unnatural and lack bass.

### ■ How to Connect:

- ① Remove the insulation coating at the extremity of each speaker cable by twisting the coating off.

### Good No Good



- ② Loosen the terminal knob.
- ③ Insert the bare wire.
- ④ Tighten the knob and secure the cable. Test the firmness of the connection by pulling lightly on the cable at the terminal.

### Note

Do not let the bare speaker wires touch each other to avoid damaging the speaker or the amplifier, or both of them.

### [Using a Banana Plug]

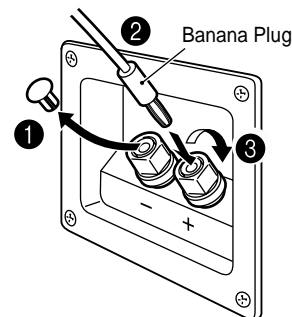

- ① Remove the speaker terminal cover by gently pulling it toward you.
- ② Tighten the terminal knob.
- ③ Simply insert the banana plug into the terminal.



## REMOVING THE FRONT COVER

The front cover is fastened to the enclosure at four points and can be removed if desired. To remove the cover, hold on to both sides and slowly pull straight away from the speaker. To reattach, line up the four pegs on the inside surface of the cover with the four corresponding holes on the speaker and push gently.

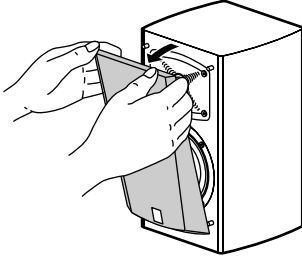

### Note

When the cover is removed, take care not to touch the speaker units with your hands or to exert excessive force with tools.

## SPECIFICATIONS

Type .....	2-way bass reflex speaker system magnetic shielding type
Driver .....	13 cm (5") cone woofer 2.5 cm (1") dome tweeter
Frequency response.....	60 Hz – 35 kHz
Nominal impedance .....	6 ohms
Nominal input power .....	60 W
Maximum input power .....	150 W
Sensitivity .....	87 dB/2.83 V/m
Crossover frequency .....	3 kHz
Dimensions (W x H x D) ...	200 mm x 320 mm x 213 mm (7.9" x 12.6" x 8.4")
Weight.....	5.5 kg (12 lbs. 2 oz.)

- Specifications subject to change without notice due to product improvements.
- Care should be taken not to exceed the input power values noted above.

Nous vous remercions d'avoir acheté un système d'enceintes YAMAHA.

## PRECAUTIONS

Lire ces précautions avant d'utiliser les enceintes.

- Pour garantir les meilleures performances possibles, lire ce manuel avec attention. Le garder dans un endroit sûr pour une utilisation ultérieure.
- Installer ces enceintes dans un endroit frais, sec et propre - loin des fenêtres, sources de chaleur et d'endroits où les vibrations, la poussière, l'humidité ou le froid sont importants. Éviter les sources de bourdonnement (transformateurs, moteurs). Afin d'éviter un incendie ou une électrocution, ne pas exposer ces enceintes à la pluie ni à l'humidité.
- Pour éviter que le coffret se gondole ou se décolore, ne pas placer les enceintes à un endroit où elles seront exposées aux rayons directs du soleil ou à une trop forte humidité.
- Ne pas placer les objets suivants sur les enceintes : Des verres, de la vaisselle, des petits objets métalliques, etc.

Des blessures pourraient être causées par des débris de verre, etc. dus aux vibrations et aux brisures.

Une bougie allumée, etc.

Si celle-ci tombe à cause des vibrations, cela peut déclencher un incendie ou causer une blessure corporelle.

Un récipient rempli d'eau

Si le récipient tombe et l'eau se renverse, le système risque d'être endommagé et/ou de vous exposer à une électrocution.

- Ne pas placer les enceintes dans un endroit où des corps étrangers comme des gouttes d'eau peuvent tomber. Ceci peut causer un incendie, des dommages aux enceintes et/ou une blessure corporelle.
- Ne pas placer les enceintes à un endroit où elles risquent d'être renversées ou percutées par des objets tombants. Un endroit bien stable améliorera aussi la qualité du son.
- Si les enceintes sont placées sur la même étagère ou dans le même meuble que le tourne-disque, un effet de retour sonore risquera de se produire.
- Si des distorsions sonores se produisent, réduire le niveau sonore en réduisant la commande de volume de l'amplificateur. Ne jamais laisser de "pincement" sonore se produire sur l'amplificateur, sinon, les enceintes risqueront d'être endommagées.
- Lorsqu'on utilise un amplificateur dont la puissance de sortie nominale est supérieure à la puissance d'entrée nominale des enceintes, veiller à ne jamais dépasser l'entrée maximale de l'enceinte.
- Ne pas essayer de nettoyer les enceintes avec des diluants chimiques, ceci endommagerait la finition. Utiliser un chiffon propre et sec.
- Ne pas essayer de modifier ou de réparer les enceintes. Contacter un réparateur YAMAHA qualifié en cas de nécessité de réparation. Le coffret ne doit jamais être ouvert pour quelque raison que ce soit.
- **Installer ou placer les enceintes dans un endroit sûr relève de la responsabilité de l'utilisateur. YAMAHA décline toute responsabilité en cas d'accident causé par un positionnement ou une installation inadéquate des enceintes.**

## POSITIONNEMENT DES ENCEINTES

Placer les enceintes sur une surface plane, immune aux vibrations, ou sur un support bien conçu.

### ■ Utilisation comme enceintes stéréo à 2 canaux

Une meilleure image stéréo est obtenue si les enceintes sont légèrement orientées vers l'auditeur.

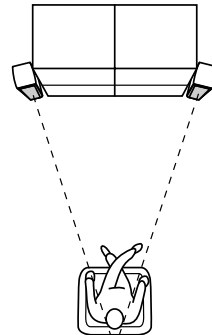

### ■ Utilisation comme enceintes principales dans un système multi-canaux

Positionner les enceintes de chaque côté du téléviseur. Le positionnement des enceintes est important car de lui dépend toute la qualité sonore d'un système multi-canaux. Positionner les enceintes par rapport à votre position d'écoute habituelle en se référant au mode d'emploi fourni avec votre amplificateur.

### ■ Utilisation comme enceintes d'effets avant ou arrière

Positionner les enceintes au mur ou sur une étagère. Déterminer le meilleur emplacement en suivant les instructions du mode d'emploi fourni avec votre amplificateur.

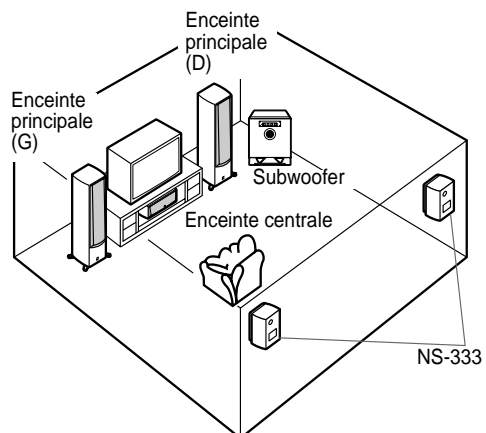

### Remarque

Cette enceinte est dotée d'un blindage magnétique, mais l'image risque de se détériorer en cas de placement à côté d'un téléviseur. Déplacer dans ce cas l'enceinte loin du téléviseur.

## ■ Installation de l'enceinte au mur à l'aide du support de montage fourni

Visser les vis dans un mur ferme ou un support mural comme montré dans l'illustration, et pendre les trous du support de montage aux vis faisant protubérance.

\* S'assurer que les vis sont fermement insérées dans les parties étroites des trous.

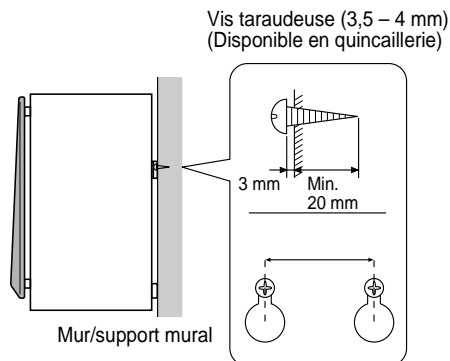

### AVERTISSEMENT

- Cette enceinte pèse 5,5 kg. Il ne faudra jamais la monter sur un panneau en contre-plaqué fin ou sur un mur composé d'un matériau non résistant. Les vis pourraient en effet ressortir très facilement de la surface, et les enceintes pourraient tomber. Ceci pourrait endommager les enceintes ou causer des blessures.
- Il ne faudra jamais monter l'enceinte sur un mur à l'aide de clous, de ruban adhésif ou d'autres matériaux de fixation instables. Une utilisation prolongée et les vibrations pourraient en causer la chute.
- Fixez les câbles des enceintes au mur afin d'éviter d'éventuelles chutes.

## CONNEXION A VOTRE AMPLIFICATEUR

Avant de réaliser les connexions, s'assurer que l'amplificateur est hors tension.

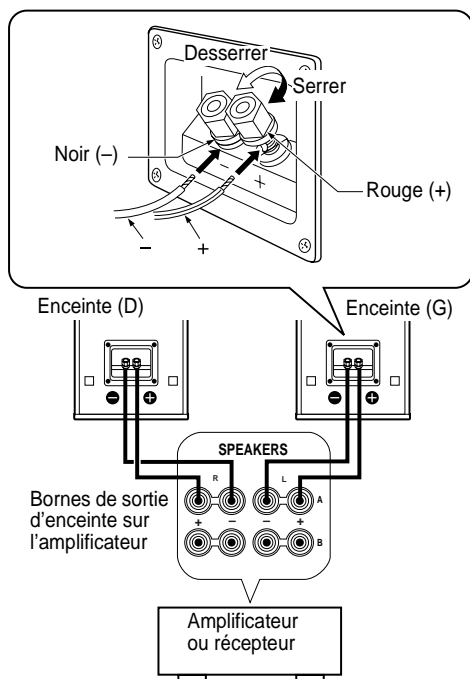

## Connexions

- Connecter les bornes à vis situées à l'arrière de l'enceinte aux bornes de sorties de l'enceinte de l'amplificateur (ou du récepteur) à l'aide du câble d'enceinte.
- Connecter les bornes (+) de l'amplificateur (ou du récepteur) à l'enceinte en utilisant un des côtés du câble. Connecter les bornes (-) de l'amplificateur (ou du récepteur) et des enceintes en utilisant l'autre côté du câble.
- Connecter l'enceinte aux bornes centrales de l'amplificateur (ou du récepteur) en faisant attention à ne pas inverser la polarité (+, -). Si l'enceinte est raccordée avec une polarité inversée, le son manquera de naturel et de graves.

### ■ Raccordement :

- ① Retirer la gaine d'isolation à l'extrémité de chaque câble d'enceinte en tortillant la gaine pour la dégager.

### Correct Incorrect



- ② Desserrer le bouton de la prise.
- ③ Insérer le câble dénudé.
- ④ Serrer le bouton pour fixer solidement le câble. Vérifier la solidité de la connexion en tirant légèrement sur le câble au niveau de la borne.

### Remarque

Ne jamais laisser les fils d'enceinte dénudés se toucher afin d'éviter d'endommager l'enceinte ou l'amplificateur, ou les deux.

### [Utilisation d'une fiche banane]

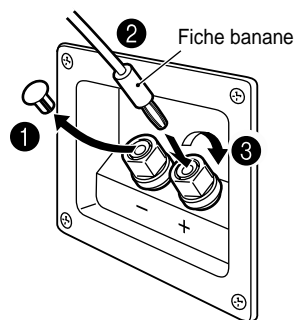

- ① Retirer le chapeau de la borne d'enceinte en le tirant doucement vers vous.
- ② Serrer le bouton de la borne.
- ③ Insérer simplement la fiche banane dans la borne.

## RETRAIT DU COUVERCLE AVANT

Le couvercle avant est fixé au coffret en quatre points et peut être déposé, si nécessaire. Pour retirer le couvercle, tenir les deux côtés et tirer légèrement en ligne droite vers l'extérieur de l'enceinte. Pour le remettre en place, aligner les quatre fiches sur l'enceinte avec les quatre trous correspondants sur la surface intérieure du couvercle et pousser légèrement.

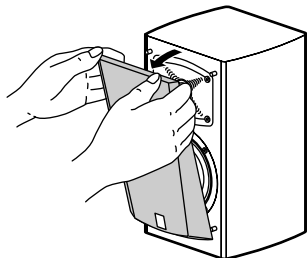

### Remarque

Quand le couvercle est retiré, faire attention de ne pas toucher les haut-parleurs avec vos mains ou avec des outils.

## CARACTERISTIQUES

Type .....	Système d'enceintes bass reflex 2 voies
	Type à blindage magnétique
Driver .....	13 cm de type cône à woofer
	Tweeter à dôme de 2,5 cm
Réponse en fréquence .....	60 Hz – 35 kHz
Impédance nominale .....	6 ohms
Puissance d'entrée nominale .....	60 W
Puissance d'entrée maximale .....	150 W
Sensibilité .....	87 dB/2,83 V/m
Fréquence de recouvrement .....	3 kHz
Dimensions (L x H x P) ....	200 mm x 320 mm x 213 mm
Poids .....	5,5 kg

- Les caractéristiques techniques sont modifiables sans préavis aux fins d'amélioration.
- Veiller à ne pas dépasser les valeurs de puissance d'entrée indiquées ci-dessus.

## 卸下前盖

前盖四周四点被扣紧，可根据需要卸下。卸下前盖时，握住两边从扬声器慢慢直拉出来。如需再安装，将前盖里层的四个钉对准扬声器四个相应的孔，轻轻地推入。

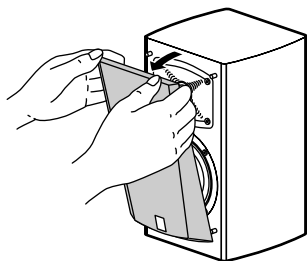

### 注意

当前盖被卸下后，切勿用手接触扬声器或用工具过分施力。

## 规格

种类.....	2 声道反射式扬声器系统 磁屏型
驱动器.....	13 cm 圆锥低音扬声器 2.5 cm 穹型高频扬声器
频率响应.....	60 Hz 至 35 kHz
额定阻抗.....	6 欧姆
额定输入功率.....	60 W
最大输入功率.....	150 W
灵敏度.....	87 dB/2.83 V/m
交换频率.....	3 kHz
尺寸（宽×高×深）.....	200 mm × 320 mm × 213 mm
重量.....	5.5 kg

- 产品规格若有变动，恕不另行通知。
- 请注意输入功率值不要超过上述值。





UB

# *YST-RSW300*

---

---

*SUBWOOFER SYSTEM*



**OWNER'S MANUAL**

# IMPORTANT SAFETY INSTRUCTIONS

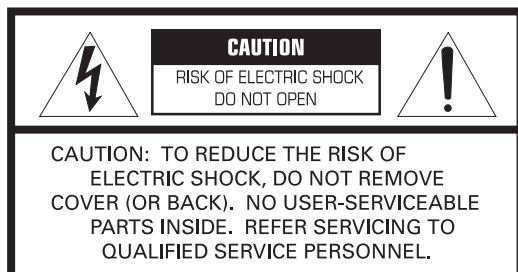

## • Explanation of Graphical Symbols



The lightning flash with arrowhead symbol, within an equilateral triangle, is intended to alert you to the presence of uninsulated "dangerous voltage" within the product's enclosure that may be of sufficient magnitude to constitute a risk of electric shock to persons.



The exclamation point within an equilateral triangle is intended to alert you to the presence of important operating and maintenance (servicing) instructions in the literature accompanying the appliance.

## WARNING

TO REDUCE THE RISK OF FIRE OR ELECTRIC SHOCK, DO NOT EXPOSE THIS APPLIANCE TO RAIN OR MOISTURE.

## IMPORTANT

Please record the serial number of this system in the space below.

Model:

Serial No.:

The serial number is located on the rear of the main unit.

Retain this Owner's Manual in a safe place for future reference.

- 1 Read these instructions.
- 2 Keep these instructions.
- 3 Heed all warnings.
- 4 Follow all instructions.
- 5 Do not use this apparatus near water.
- 6 Clean only with dry cloth.
- 7 Do not block any ventilation openings. Install in accordance with the manufacturer's instructions.
- 8 Do not install near any heat sources such as radiators, heat registers, stoves, or other apparatus (including amplifiers) that produce heat.
- 9 Do not defeat the safety purpose of the polarized or grounding-type plug. A polarized plug has two blades with one wider than the other. A grounding type plug has two blades and a third grounding prong. The wide blade or the third prong are provided for your safety. If the provided plug does not fit into your outlet, consult an electrician for replacement of the obsolete outlet.
- 10 Protect the power cord from being walked on or pinched particularly at plugs, convenience receptacles, and the point where they exit from the apparatus.
- 11 Only use attachments/accessories specified by the manufacturer.
- 12 Use only with the cart, stand, tripod, bracket, or table specified by the manufacturer, or sold with the apparatus. When a cart is used, use caution when moving the cart/apparatus combination to avoid injury from tip-over.
- 13 Unplug this apparatus during lightning storms or when unused for long periods of time.
- 14 Refer all servicing to qualified service personnel. Servicing is required when the apparatus has been damaged in any way, such as power-supply cord or plug is damaged, liquid has been spilled or objects have fallen into the apparatus, the apparatus has been exposed to rain or moisture, does not operate normally, or has been dropped.



- Be sure to allow spaces of at least 20 cm above, behind and on both sides of the unit.
- Do not place the following objects on the unit:  
A vessel with water in it.  
If the vessel falls by vibrations and water spills, it may cause damage to the unit, and/or you may get an electric shock.

## **FCC INFORMATION (for US customers)**

### **1 IMPORTANT NOTICE : DO NOT MODIFY THIS UNIT!**

This product, when installed as indicated in the instructions contained in this manual, meets FCC requirements. Modifications not expressly approved by Yamaha may void your authority, granted by the FCC, to use the product.

### **2 IMPORTANT :** When connecting this product to accessories and/or another product use only high quality shielded cables. Cable/s supplied with this product **MUST** be used. Follow all installation instructions. Failure to follow instructions could void your FCC authorization to use this product in the USA.

### **3 NOTE :** This product has been tested and found to comply with the requirements listed in FCC Regulations, Part 15 for Class "B" digital devices. Compliance with these requirements provides a reasonable level of assurance that your use of this product in a residential environment will not result in harmful interference with other electronic devices.

This equipment generates/uses radio frequencies and, if not installed and used according to the instructions found in the users manual, may cause interference harmful to the operation of other electronic devices.

Compliance with FCC regulations does not guarantee that interference will not occur in all installations. If this product is found to be the source of interference, which can be determined by turning the unit "OFF" and "ON", please try to eliminate the problem by using one of the following measures:

Relocate either this product or the device that is being affected by the interference.

Utilize power outlets that are on different branch (circuit breaker or fuse) circuits or install AC line filter/s.

In the case of radio or TV interference, relocate/reorient the antenna. If the antenna lead-in is 300 ohm ribbon lead, change the lead-in to coaxial type cable.

If these corrective measures do not produce satisfactory results, please contact the local retailer authorized to distribute this type of product. If you can not locate the appropriate retailer, please contact Yamaha Electronics Corp., U.S.A. 6660 Orangethorpe Ave, Buena Park, CA 90620.

The above statements apply **ONLY** to those products distributed by Yamaha Corporation of America or its subsidiaries.

## **We Want You Listening For A Lifetime**

YAMAHA and the Electronic Industries Association's Consumer Electronics Group want you to get the most out of your equipment by playing it at a safe level. One that lets the sound come through loud and clear without annoying blaring or distortion – and, most importantly, without affecting your sensitive hearing.

Since hearing damage from loud sounds is often undetectable until it is too late, YAMAHA and the Electronic Industries Association's Consumer Electronics Group recommend you to avoid prolonged exposure from excessive volume levels.





## CAUTION: Read this before operating your unit.

Please read the following operating precautions before use.

Yamaha will not be held responsible for any damage and/or injury caused by not following the cautions below.

- To assure the finest performance, please read this manual carefully. Keep it in a safe place for future reference.
- Install this unit in a cool, dry, clean place - away from windows, heat sources, sources of excessive vibration, dust, moisture and cold. Avoid sources of humming (transformers, motors). To prevent fire or electrical shock, do not expose this unit to rain or water.
- Never open the cabinet. If something drops into the set, contact your dealer.
- The voltage to be used must be the same as that specified on the rear panel. Using this unit with a higher voltage than specified is dangerous and may cause a fire and/or electric shock.
- To reduce the risk of fire or electric shock, do not expose this unit to rain or moisture.
- Do not use force on switches, controls or connection wires. When moving the unit, first disconnect the power plug and the wires connected to other equipment. Never pull the wires themselves.
- When not planning to use this unit for a long period (ie., vacation, etc.), disconnect the AC power plug from the wall outlet.
- Since this unit has a built-in power amplifier, heat will radiate from the rear panel. Place the unit apart from the walls, allowing at least 20 cm of space above, behind and on both sides of the unit to prevent fire or damage. Furthermore, do not position with the rear panel facing down on the floor or other surfaces.
- Do not cover the rear panel of this unit with a newspaper, a tablecloth, a curtain, etc. in order not to obstruct heat radiation. If the temperature inside the unit rises, it may cause fire, damage to the unit and/or personal injury.
- Do not place the following objects on this unit:
  - Glass, china, small metallic etc.  
If glass etc. falls by vibrations and breaks, it may cause bodily injury.
  - A burning candle etc.  
If the candle falls by vibrations, it may cause fire and bodily injury.
  - A vessel with water in it  
If the vessel falls by vibrations and water spills, it may cause damage to the speaker, and/or you may get an electric shock.
- Do not place this unit where foreign objects such as water drips might fall. It might cause a fire, damage to this unit, and/or personal injury.
- Never put a hand or a foreign object into the YST port located on the right side of this unit. When moving this unit, do not hold the port as it might cause personal injury and/or damage to this unit.
- Never place a fragile object near the YST port of this unit. If the object falls or drops by the air pressure, it may cause damage to the unit and/or personal injury.
- Never open the cabinet. It might cause an electric shock since this unit uses a high voltage. It might also cause personal injury and/or damage to this unit.
- When using a humidifier, be sure to avoid condensation inside this unit by allowing enough spaces around this unit or avoiding excess humidification. Condensation might cause a fire, damage to this unit, and/or electric shock.
- Super-bass frequencies reproduced by this unit may cause a turntable to generate a howling sound. In such a case, move this unit away from the turntable.
- This unit may be damaged if certain sounds are continuously output at high volume level. For example, if 20 Hz-50 Hz sine waves from a test disc, bass sounds from electronic instruments, etc. are continuously output, or when the stylus of a turntable touches the surface of a disc, reduce the volume level to prevent this unit from being damaged.
- If you hear distorted noise (i.e., unnatural, intermittent “rapping” or “hammering” sounds) coming from this unit, reduce the volume level. Extremely loud playing of a movie soundtrack’s low frequency, bass-heavy sounds or similarly loud popular music passages can damage this speaker system.
- Vibration generated by super-bass frequencies may distort images on a TV. In such a case, move this unit away from the TV set.
- Do not attempt to clean this unit with chemical solvents as this might damage the finish. Use a clean, dry cloth.
- Be sure to read the “TROUBLESHOOTING” section regarding common operating errors before concluding that the unit is faulty.
- Install this unit near the wall outlet and where the AC power plug can be reached easily.
- **Secure placement or installation is the owner’s responsibility. Yamaha shall not be liable for any accident caused by improper placement or installation of speakers.**

This unit features a magnetically shielded design, but there is still a chance that placing it too close to a TV set might impair picture color. Should this happen, move this unit away from the TV set.

This unit is not disconnected from the AC power source as long as it is connected to the wall outlet, even if this unit itself is turned off. In this state, this unit is designed to consume a very small quantity of power.

## SPECIAL INSTRUCTIONS FOR U.K. MODEL

### IMPORTANT:

THE WIRES IN MAINS LEAD ARE COLOURED IN ACCORDANCE WITH THE FOLLOWING CODE:

Blue: NEUTRAL

Brown: LIVE

As the colours of the wires in the mains lead of this apparatus may not correspond with the coloured markings identifying the terminals in your plug, proceed as follows: The wire which is coloured BLUE must be connected to the terminal which is marked with the letter N or coloured BLACK. The wire which is coloured BROWN must be connected to the terminal which is marked with the letter L or coloured RED. Making sure that neither core is connected to the earth terminal of the three pin plug.

### For U.K. customers

If the socket outlets in the home are not suitable for the plug supplied with this appliance, it should be cut off and an appropriate 3 pin plug fitted. For details, refer to the instructions described below.

**Note:** The plug severed from the mains lead must be destroyed, as a plug with bared flexible cord is hazardous if engaged in a live socket outlet.

### For Canadian Customers

To prevent electric shock, match wide blade of plug to wide slot and fully insert.

This Class B digital apparatus complies with Canadian ICES-003.

### VOLTAGE SELECTOR

(For Asia and General models only)

**The voltage selector switch on the rear panel of this unit must be set for your local main voltage BEFORE plugging this unit into the AC main supply. Voltages are 110/120/220/230-240 V AC, 50/60 Hz.**

## CONTENTS

FEATURES .....	2
SUPPLIED ACCESSORIES .....	2
PLACEMENT .....	3
CONTROLS AND THEIR FUNCTIONS .....	4
CONNECTIONS .....	6
[1] Connecting to line output (pin jack) terminals of the amplifier .....	6
[2] Connecting to speaker output terminals of the amplifier .....	8
Connecting to the INPUT1/OUTPUT terminals of the subwoofer .....	10
Plug in the subwoofer to the AC outlet .....	11
ADJUSTING THE SUBWOOFER BEFORE USE .....	12
AUTOMATIC POWER-SWITCHING FUNCTION .....	13
Changing the AUTO STANDBY setting .....	13
FREQUENCY CHARACTERISTICS .....	14
ADVANCED YAMAHA ACTIVE SERVO TECHNOLOGY II .....	15
TROUBLESHOOTING .....	16
SPECIFICATIONS .....	17

## FEATURES

- This subwoofer system employs Advanced Yamaha Active Servo Technology II, which Yamaha has developed for reproducing higher quality super-bass sound (refer to page 15 for details on Advanced Yamaha Active Servo Technology II). This super-bass sound adds a more realistic, theater-in-the-home effect to your stereo system.
- This subwoofer can be easily added to your existing audio system by connecting to either the speaker terminals or the line output (pin jack) terminals of the amplifier.
- For the effective use of the subwoofer, the subwoofer's super-bass sound should be matched to the sounds of your main speakers. You can create the best sound quality for various listening conditions by using the HIGH CUT control and the PHASE switch.
- The Automatic power-switching function saves you the trouble of pressing the STANDBY/ON button to turn the power on and off.
- This subwoofer system is equipped with a linear port unique to Yamaha that provides smooth bass response during playback, minimizing extraneous noise not included in the original input signal.

## SUPPLIED ACCESSORIES

After unpacking, check that the following parts are contained.

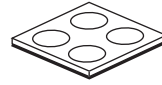

Non-skid pads (1 set: 4 pieces)

# PLACEMENT

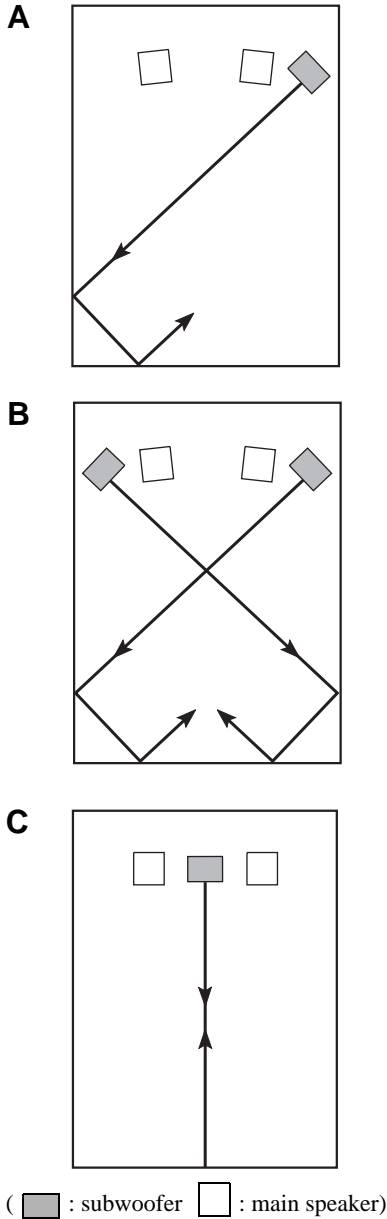

One subwoofer will have a good effect on your audio system, however, the use of two subwoofers is recommended to obtain more effect.

If using one subwoofer, it is recommended to place it on the outside of either the right or the left main speaker (see A). If using two subwoofers, it is recommended to place them on the outside of each main speaker (see B). The placement shown in C is also possible, however, if the subwoofer system is placed directly facing the wall, the bass effect may die because the sound from it and the sound reflected by the wall may cancel out each other. To prevent this from happening, face the subwoofer system at an angle as in A or B.

## Note

There may be a case that you cannot obtain enough super-bass sounds from the subwoofer when listening in the center of the room. This is because “standing waves” have been developed between two parallel walls and they cancel the bass sounds. In such a case, face the subwoofer obliquely to the wall. It also may be necessary to break up the parallel surfaces by placing bookshelves etc. along the walls.

## Use the non-skid pads

Put the provided non-skid pads at the four corners on the bottom of the subwoofer to prevent the subwoofer from moving by vibrations etc.

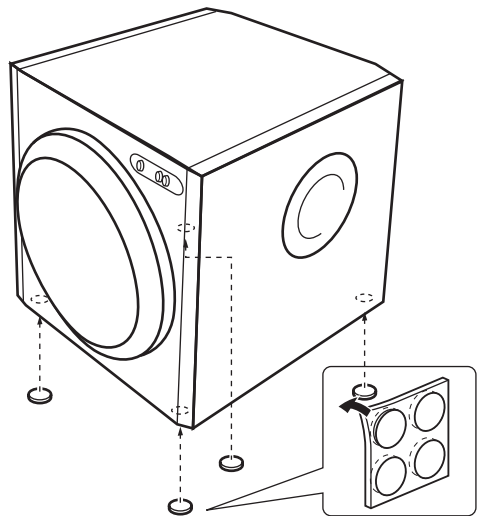

# CONTROLS AND THEIR FUNCTIONS

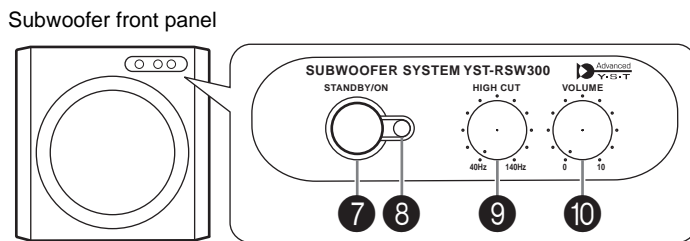
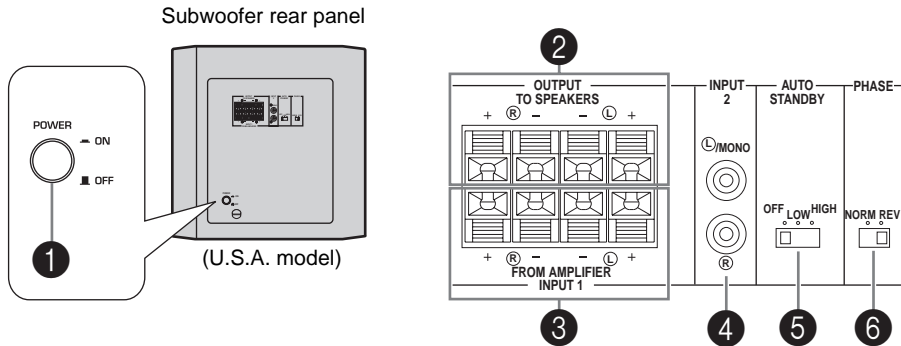

## 1 POWER switch

Normally, set this switch to the **ON** position to use the subwoofer. In this state, you can turn on the subwoofer or turn the subwoofer into the standby mode by pressing the **STANDBY/ON** switch.

## 2 OUTPUT (TO SPEAKERS) terminals

Can be used for connecting to the front speakers. Signals from the **INPUT1** terminals are sent to these terminals.  
(Refer to "CONNECTIONS" for details.)

## 3 INPUT1 (FROM AMPLIFIER) terminals

Used to connect the subwoofer with the speaker terminals of the amplifier.  
(Refer to "CONNECTIONS" for details.)

## 4 INPUT2 terminals

Used to input line level signals from the amplifier.  
(Refer to "CONNECTIONS" for details.)

## 5 AUTO STANDBY (OFF/LOW/HIGH) switch

This switch is originally set to the **OFF** position. By setting this switch to the **HIGH** or **LOW** position, the subwoofer's automatic power-switching function operates as described on page 13. If you do not need this function, leave this switch in the **OFF** position.

### Note

Make sure to change the setting of this switch only when the subwoofer is set in the standby mode by pressing the **STANDBY/ON** switch.

## 6 PHASE (NORM/REV) switch

Normally, this switch is to be set to the **REV** (reverse) position. However, according to your speaker systems or the listening condition, there may be a case when better sound quality is obtained by setting this switch to the **NORM** (normal) position. Select the better position by monitoring the sound.

**7 STANDBY/ON switch**

Press this switch to turn on the power when the **POWER** switch is set in the **ON** position (the status indicator lights up in green). Press again to set the subwoofer in the standby mode (the status indicator goes off).

**Note**

Even while the subwoofer is in the standby mode, it is still using a small amount of power.

**8 Status indicator**

Lights up in green while the subwoofer is on.

Lights up in red while the subwoofer is set in the standby mode by the operation of the automatic power-switching function.

Goes off when the subwoofer is set in the standby mode.

**9 HIGH CUT control**

Adjusts the high frequency cut off point. Frequencies higher than the frequency selected by this control are all cut off (and no output). One graduation of this control represents 10 Hz.

**10 VOLUME control**

Adjusts the volume level. Turn the control clockwise to increase the volume, and counterclockwise to decrease the volume.

# CONNECTIONS

Choose one of the following two connecting methods that is more suitable for your audio system.

- **Choose [1] (pages 6-7) if your amplifier has line output (pin jack) terminal(s)**
- **Choose [2] (pages 8-9) if your amplifier has no line output (pin jack) terminal**

## Caution

**Unplug the subwoofer and other audio/video components before making connections.**

## Notes

- All connections must be correct, that is to say L (left) to L, R (right) to R, “+” to “+” and “-” to “-”. Also, refer to the owner’s manual of your component to be connected to the subwoofer.
- After all connections are completed, plug in the subwoofer and other audio/video components.

## [1] Connecting to line output (pin jack) terminals of the amplifier

- To connect with a Yamaha DSP amplifier (or AV receiver), connect the SUBWOOFER (or LOW PASS etc.) terminal on the rear of the DSP amplifier (or AV receiver) to the **(L)**/MONO INPUT2 terminal of the subwoofer.
- When connecting the subwoofer to the SPLIT SUBWOOFER terminals on the rear of the DSP amplifier, be sure to connect the **(L)**/MONO INPUT2 terminal to the “L” side and the **(R)** INPUT2 terminal to the “R” side of the SPLIT SUBWOOFER terminals.

## Notes

- Some amplifiers have line output terminals labeled PRE OUT. When you connect the subwoofer to the PRE OUT terminals of the amplifier, make sure that the amplifier has at least two sets of PRE OUT terminals. If the amplifier has only one set of PRE OUT terminals, do not connect the subwoofer to the PRE OUT terminals. Instead, connect the subwoofer to the speaker output terminals of the amplifier (refer to pages 8-9).
- When connecting to a monaural line output terminal of the amplifier, connect the **(L)**/MONO INPUT2 terminal.
- When connecting to line output terminals of the amplifier, other speakers should not be connected to the OUTPUT terminals on the rear panel of the subwoofer. If connected, they will not produce sound.

■ Using one subwoofer

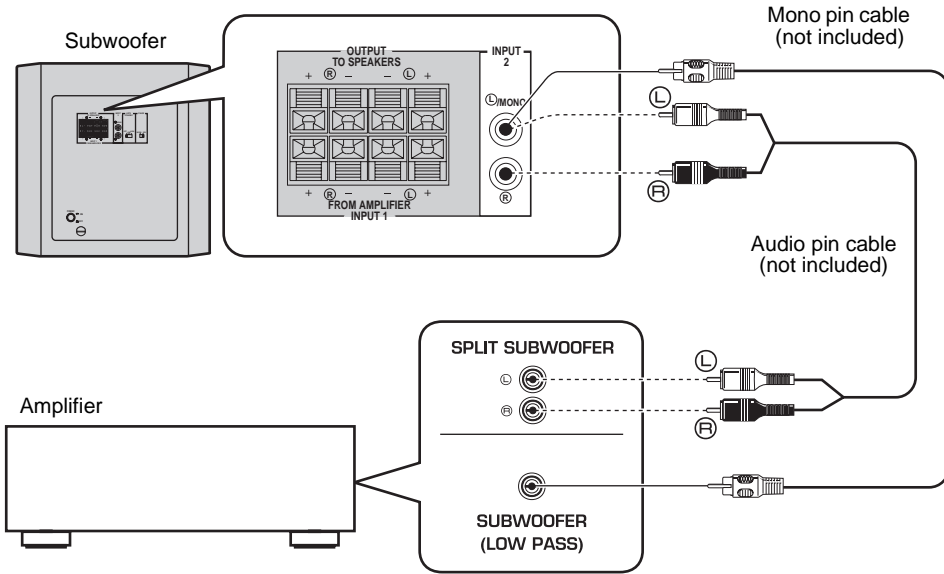

■ Using two subwoofers

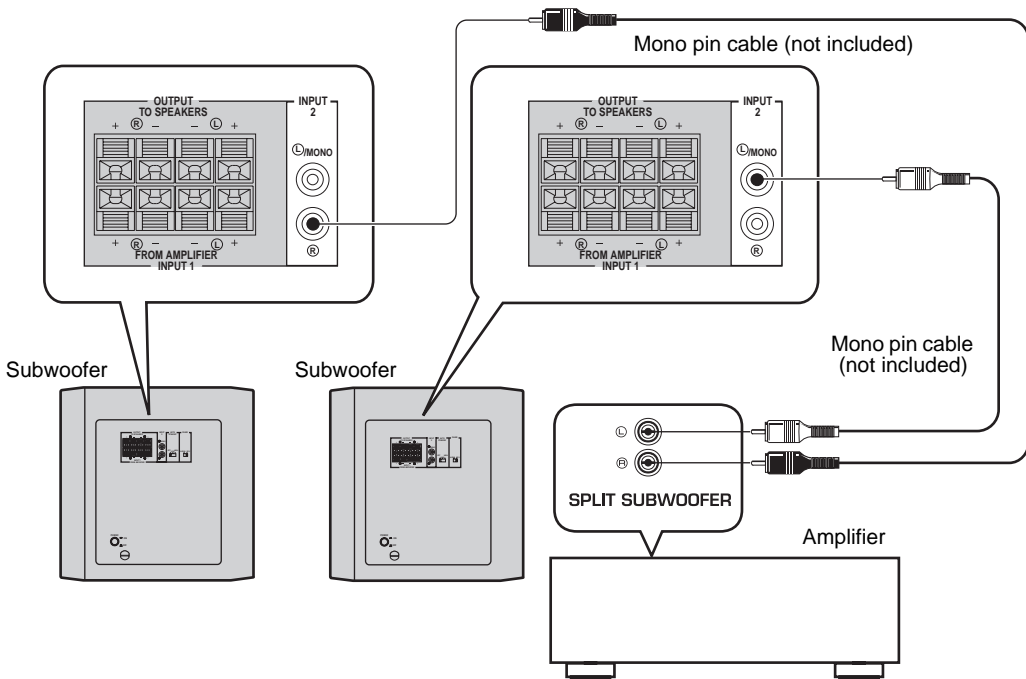



## [2] Connecting to speaker output terminals of the amplifier

Select this method if your amplifier has no line output (pin jack) terminal. For details about the connection method of the INPUT1/OUTPUT terminals, see the “Connecting to the INPUT1/OUTPUT terminals of the subwoofer” on page 10.

### If your amplifier has two sets of main speaker output terminals and both terminals can output sound signals simultaneously:

- Connect one set of main speaker output terminals of the amplifier to the INPUT1 terminals of the subwoofer, and connect the other set of main speaker output terminals of the amplifier to the main speakers.
- Set the amplifier so that both sets of main speaker output terminals output sound signals simultaneously.

#### Note

If your amplifier has only one set of main speaker output terminals, see page 9.

#### ■ Using one subwoofer (with speaker cables)

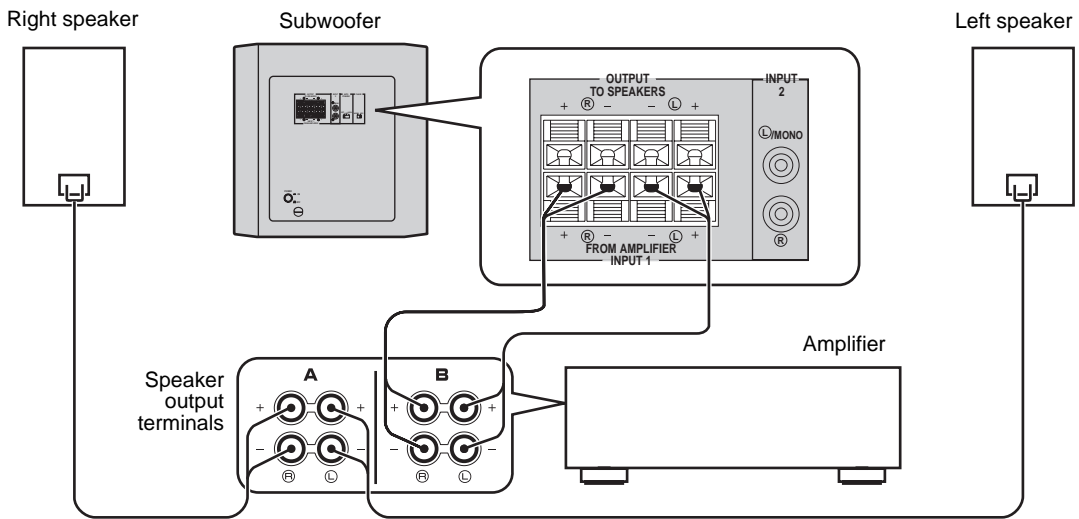

#### ■ Using two subwoofers (with speaker cables)

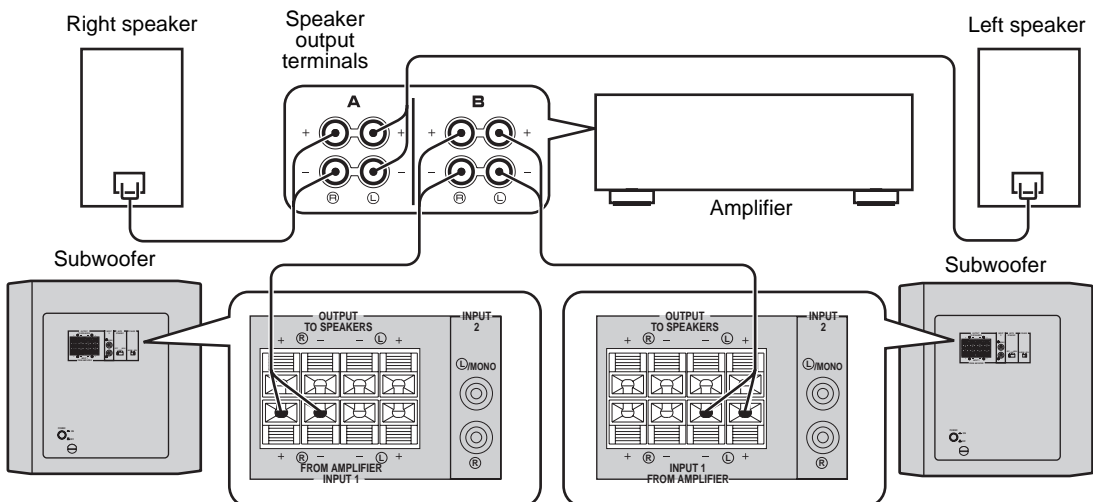

**If your amplifier has only one set of main speaker output terminals:**

Connect the speaker output terminals of the amplifier to the INPUT1 terminals of the subwoofer, and connect the OUTPUT terminals of the subwoofer to the main speakers.

**■ Using one subwoofer (with speaker cables)**

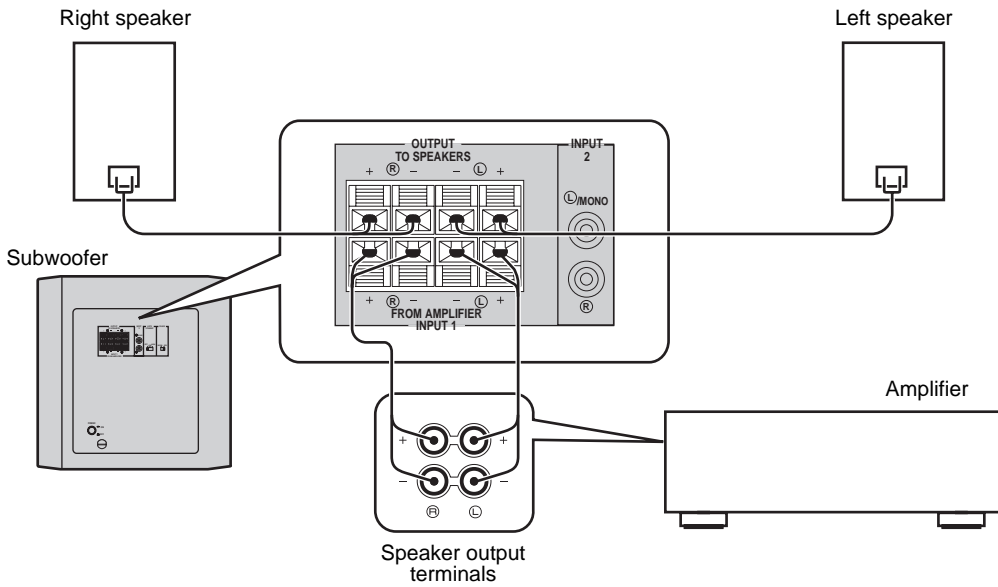

**■ Using two subwoofers (with speaker cables)**

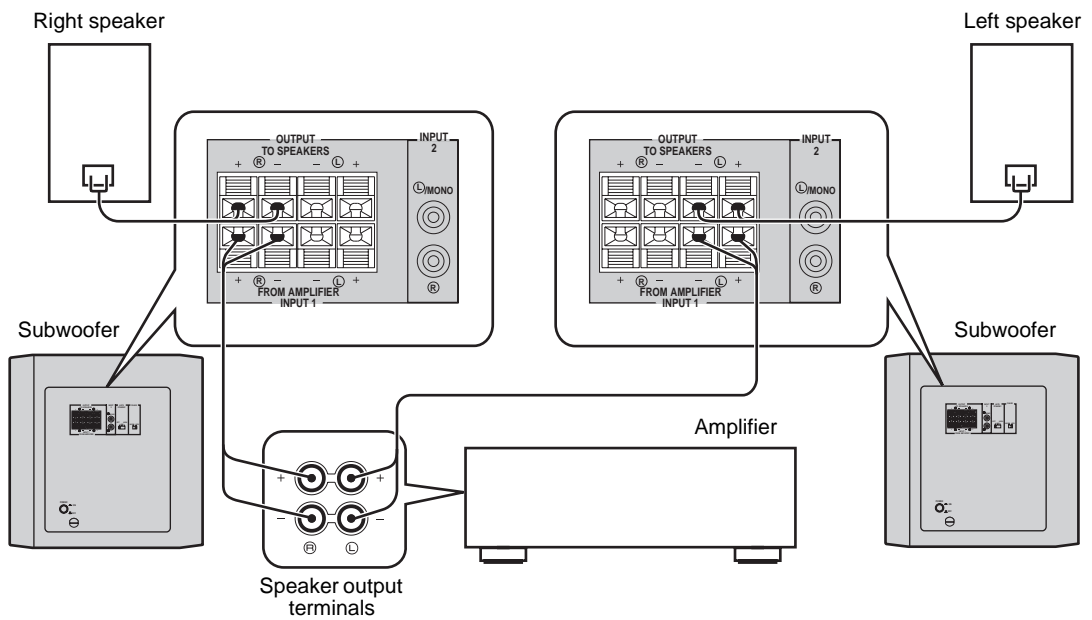

## Connecting to the INPUT1/OUTPUT terminals of the subwoofer

For connection, keep the speaker cables as short as possible. Do not bundle or roll up the excess part of the cables. If the connections are faulty, no sound will be heard from the subwoofer or the speakers, or both of them. Make sure that the + and – polarity markings of the speaker cables are observed and set correctly. If these cables are reversed, the sound will be unnatural and lack bass.

### Caution

**Do not let the bare speaker wires touch each other, because this could damage the subwoofer or the amplifier, or both of them.**

### ■ Before connecting

Remove the insulation coating at the extremity of each speaker cable by twisting the coating off.

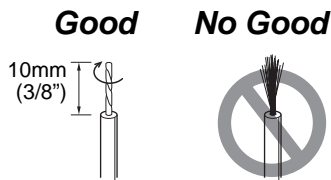

### ■ How to connect

- ① Press and hold the terminal's tab, as shown in the figure below.
- ② Insert the bare wire.
- ③ Release your finger from the tab to allow it to lock securely on the cable's wire end.
- ④ Test the firmness of the connection by pulling lightly on the cable at the terminal.

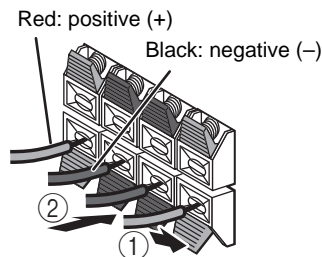

### Note

Do not insert the insulation coating into the hole. The sound may not be produced.

**Plug in the subwoofer to the AC outlet**

After all connections are completed, plug in the subwoofer and other audio/video components to the AC outlet.

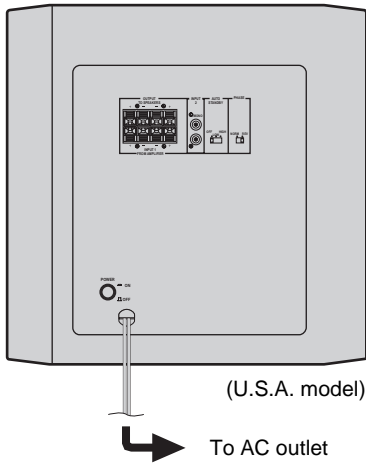

**VOLTAGE SELECTOR switch (For Asia and General models only)**

This unit has a voltage selector switch on the rear panel. If the preset setting of the switch is incorrect, set the switch to the proper voltage range (110/120/220/230-240 V) of your area. Consult your dealer if you are unsure of the correct setting.

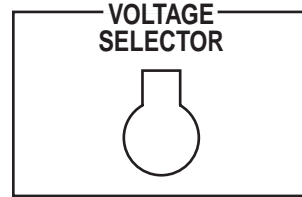

**WARNING**

Do not plug the subwoofer to the AC outlet before setting the VOLTAGE SELECTOR.

# ADJUSTING THE SUBWOOFER BEFORE USE

Before using the subwoofer, adjust the subwoofer to obtain the optimum volume and tone balance between the subwoofer and the main speakers by following the procedures described below.

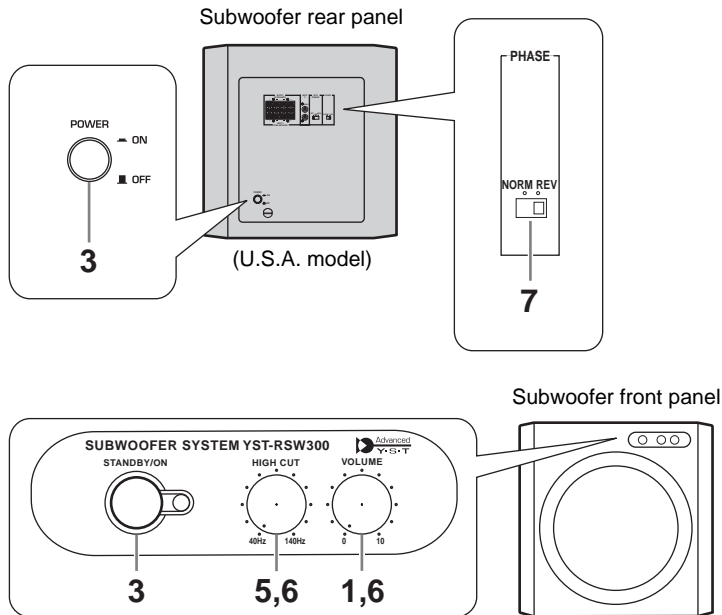

- 1 Set the **VOLUME** control to minimum (0).
- 2 Turn on the power of all the other components.
- 3 Make sure that the **POWER** switch on the rear panel is set to the **ON** position, then press the **STANDBY/ON** switch on the front panel to turn on the subwoofer.  
\* The status indicator lights up in green.
- 4 Play a source containing low-frequency signals and adjust the amplifier's volume control to the desired listening level.
- 5 Adjust the **HIGH CUT** control to the position where the desired response can be obtained. Normally, set the control to the level a little higher than the main speaker's rated minimum reproducible frequency\*.  
\* The main speaker's rated minimum reproducible frequency can be looked up in the speakers' catalog or owner's manual.
- 6 Increase the volume gradually to adjust the volume balance between the subwoofer and the main speakers. Normally, set the control to the level where you can obtain a little more bass effect than when the subwoofer is not used. If the desired response cannot be obtained, adjust the **HIGH CUT** control and the **VOLUME** control again.
- 7 Set the **PHASE** switch to the position which gives you the better bass sound. Normally, set the switch to the **REV** (reverse) position. If the desired response cannot be obtained, set the switch to the **NORM** (normal) position.

## Notes

- Once the volume balance between the subwoofer and the main speakers is adjusted, you can adjust the volume of your whole sound system by using the amplifier's volume control. However, if you change the main speakers to others, you must make this adjustment again.
- For adjusting the **VOLUME** control, the **HIGH CUT** control and the **PHASE** switch, refer to "FREQUENCY CHARACTERISTICS" on page 14.

# AUTOMATIC POWER-SWITCHING FUNCTION

This function automatically switches the unit between standby and power-on modes.

- The subwoofer automatically places itself in standby mode if it does not receive an input signal for 7 or 8 minutes (the status indicator lights red).
- When the subwoofer detects a bass signal input of below 200 Hz, it automatically places itself in power-on mode (the status indicator lights green).

## Changing the AUTO STANDBY setting

- 1 Set the subwoofer to standby.
- 2 Change the **AUTO STANDBY** setting.
  - **LOW**: Normally select this position to activate this function.
  - **HIGH**: If this function does not operate with **AUTO STANDBY** switch set to **LOW**, select this position so that the subwoofer detects input signals with a lower level and switches the power on automatically.
  - **OFF**: Select this position to deactivate this function, for example, when the subwoofer switches the power on unexpectedly by sensing noises from other appliances.

### Notes

- This function does not operate when the **POWER** switch is set to the **OFF** position, or when you manually set the subwoofer to the standby mode by pressing the **STANDBY/ON** switch.
- Noise received from other appliances may extend the time period before the subwoofer places itself in the standby mode to more than 8 minutes.

# FREQUENCY CHARACTERISTICS

This subwoofer's frequency characteristics

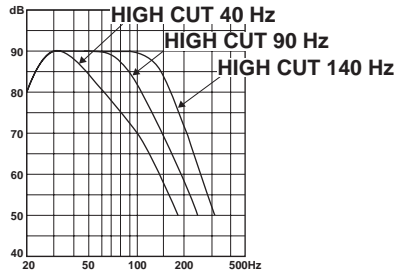

The figures below show the optimum adjustment of each control and the frequency characteristics when this subwoofer is combined with a typical main speaker system.

## Example 1

When combined with a 4" or 5" (10 cm or 13 cm) acoustic suspension, 2 way system main speakers:

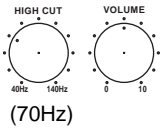

(70Hz)

### PHASE

NORM REV



(REV)

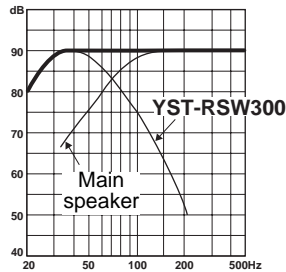

Frequency response graph\*

## Example 2

When combined with an 8" or 10" (20 cm or 25 cm) acoustic suspension, 2 way system main speakers:

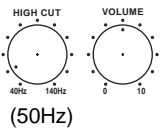

(50Hz)

### PHASE

NORM REV



(REV)

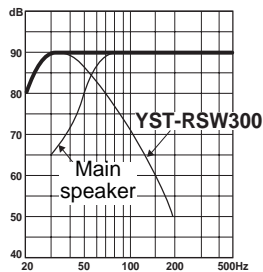

Frequency response graph\*

\*This diagram does not depict actual frequency response characteristics accurately.

## ADVANCED YAMAHA ACTIVE SERVO TECHNOLOGY II

In 1988, Yamaha brought to the marketplace speaker systems utilizing YST (Yamaha Active Servo Technology) to give powerful, high quality bass reproduction. This technique uses a direct connection between the amplifier and speaker, allowing accurate signal transmission and precise speaker control.

As this technology uses speaker units controlled by the negative impedance drive of the amplifier and resonance generated between the speaker cabinet volume and port, it creates more resonant energy (the “air woofer” concept) than the standard bass reflex method. This allows bass reproduction from much smaller cabinets than before.

Yamaha’s newly developed Advanced YST II adds many refinements to Yamaha Active Servo Technology, allowing better control of the forces driving the amplifier and speaker. From the amplifier’s point of view, the speaker impedance changes depending on the sound frequency. Yamaha developed a new circuit design combining negative-impedance and constant-current drives, which provides a more stable performance and clear bass reproduction without any murkiness.

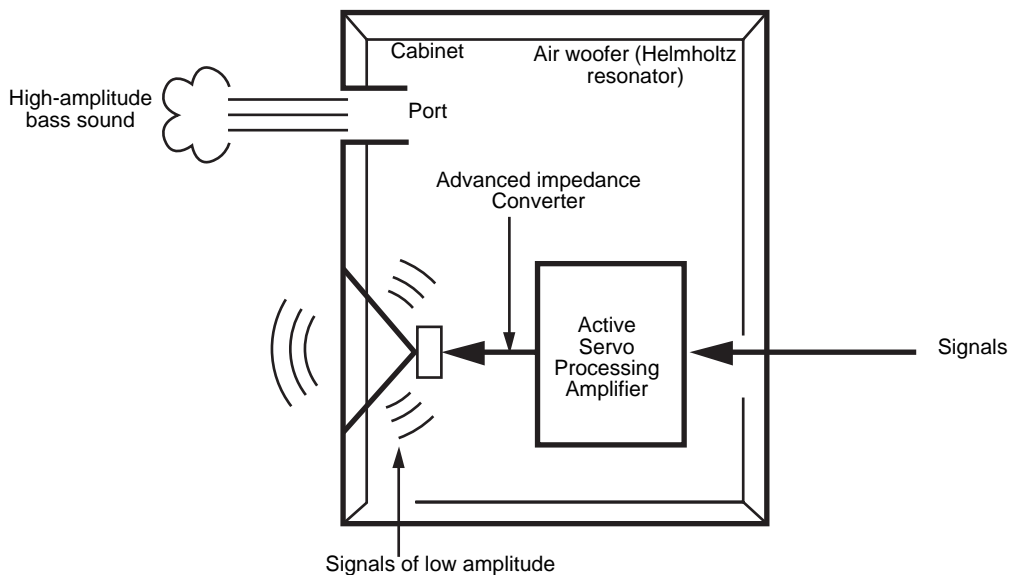



# TROUBLESHOOTING

Refer to the chart below when this unit does not function properly. If the problem you are experiencing is not listed below or if the instructions given below do not help, disconnect the power cord and contact your authorized Yamaha dealer or service center.

Problem	Cause	What to Do
<b>Power is not supplied even though the STANDBY/ON switch is set to the ON position.</b>	The power plug is not securely connected.	Connect it securely.
	The <b>POWER</b> switch is set to the <b>OFF</b> position.	Set the <b>POWER</b> switch to the <b>ON</b> position.
<b>No sound.</b>	The volume is set to minimum.	Raise the volume up.
	Speaker cables are not connected securely.	Connect them securely.
<b>Sound level is too low.</b>	Speaker cables are not connected correctly.	Connect them correctly, that is L (left) to L, R (right) to R, “+” to “+” and “-” to “-”.
	Setting of the <b>PHASE</b> switch is not proper.	Set the <b>PHASE</b> switch to the other position.
	A source sound with few bass frequencies is played.	Play a source sound with bass frequencies. Set the <b>HIGH CUT</b> control to a higher position.
	It is influenced by standing waves.	Reposition the subwoofer or break up the parallel surface by placing bookshelves etc. along the walls.
<b>The subwoofer does not turn on automatically.</b>	The <b>POWER</b> switch is set to the <b>OFF</b> position.	Set the <b>POWER</b> switch to the <b>ON</b> position.
	The <b>STANDBY/ON</b> switch is set to the <b>STANDBY</b> position.	Set the <b>STANDBY/ON</b> switch to the <b>ON</b> position.
	The <b>AUTO STANDBY</b> switch is set to the <b>OFF</b> position.	Set the <b>AUTO STANDBY</b> switch to the “ <b>HIGH</b> ” or “ <b>LOW</b> ” position.
	The level of input signal is too low.	Set the <b>AUTO STANDBY</b> switch to the “ <b>HIGH</b> ” position.
<b>The subwoofer does not turn into the standby mode automatically.</b>	There is an influence of noise generated from external appliances etc.	Move the subwoofer farther away from such appliances and/or reposition the connected speaker cables. Otherwise, set the <b>AUTO STANDBY</b> switch to the <b>OFF</b> position.
	The <b>AUTO STANDBY</b> switch is set to the <b>OFF</b> position.	Set the <b>AUTO STANDBY</b> switch to the “ <b>HIGH</b> ” or “ <b>LOW</b> ” position.
<b>The subwoofer turns into the standby mode unexpectedly.</b>	The level of input signal is too low.	Set the <b>AUTO STANDBY</b> switch to the “ <b>HIGH</b> ” position.
<b>The subwoofer turns on unexpectedly.</b>	There is an influence of noise generated from external appliances etc.	Move the subwoofer farther away from such appliances and/or reposition the connected speaker cables. Otherwise, set the <b>AUTO STANDBY</b> switch to the <b>OFF</b> position.

# SPECIFICATIONS

Type .....	Advanced Yamaha Active Servo Technology II	Power Supply	
Driver .....	25 cm (10") cone woofer Magnetic shielding type	U.S.A. and Canada models .....	AC 120V, 60 Hz
Output Power .....	250 W (100 Hz, 5 $\Omega$ 10% T.H.D)	U.K. and Europe models .....	AC 230V, 50 Hz
Dynamic Power .....	270 W, 5 $\Omega$	Australia model .....	AC 240V, 50 Hz
Input Sensitivity (50 Hz, 250 W/5 $\Omega$ , L+R)		Asia and General models .....	AC 110/120/220/230-240 V, 50/60 Hz
Speaker terminal .....	1.0 V	Korea model .....	AC 220V, 60 Hz
RCA pin jack .....	50 mV	Power Consumption .....	80 W
Input Impedance		Standby Power Consumption .....	0.5 W
Speaker terminal .....	2.2 k $\Omega$	Dimensions (W x H x D)	
RCA pin jack .....	12 k $\Omega$	.....	372 mm x 400 mm x 428 mm (14-5/8" x 15-3/4" x 16-7/8")
Frequency Response .....	20 Hz - 160 Hz	Weight .....	20 kg (44 lbs. 1oz.)

\* Please note that all specifications are subject to change without notice.







© 2007 YAMAHA CORPORATION All rights reserved.

YAMAHA ELECTRONICS CORPORATION, USA 6660 ORANGETHORPE AVE., BUENA PARK, CALIF. 90620, U.S.A.  
YAMAHA CANADA MUSIC LTD. 135 MILNER AVE., SCARBOROUGH, ONTARIO M1S 3R1, CANADA  
YAMAHA ELECTRONIK EUROPA G.m.b.H. SIEMENSSTR. 22-34, 25462 RELLINGEN BEI HAMBURG, GERMANY  
YAMAHA ELECTRONIQUE FRANCE S.A. RUE AMBROISE CROIZAT BP70 CROISSY-BEAUBOURG 77312 MARNE-LA-VALLEE CEDEX02, FRANCE  
YAMAHA ELECTRONICS (UK) LTD. YAMAHA HOUSE, 200 RICKMANSWORTH ROAD WATFORD, HERTS WD18 7GQ, ENGLAND  
YAMAHA SCANDINAVIA A.B. J A WETTERGRENS GATA 1, BOX 30053, 400 43 VÄSTRA FRÖLUNDA, SWEDEN  
YAMAHA MUSIC AUSTRALIA PTY, LTD. 17-33 MARKET ST., SOUTH MELBOURNE, 3205 VIC., AUSTRALIA

YAMAHA CORPORATION  
Printed in Indonesia © WK23240