



PORTATONE **EZ-30**

Owner's Manual



SPECIAL MESSAGE SECTION

This product utilizes batteries or an external power supply (adapter). DO NOT connect this product to any power supply or adapter other than one described in the manual, on the name plate, or specifically recommended by Yamaha.

This product should be used only with the components supplied or; a cart, rack, or stand that is recommended by Yamaha. If a cart, etc., is used, please observe all safety markings and instructions that accompany the accessory product.

SPECIFICATIONS SUBJECT TO CHANGE:

The information contained in this manual is believed to be correct at the time of printing. However, Yamaha reserves the right to change or modify any of the specifications without notice or obligation to update existing units.

This product, either alone or in combination with an amplifier and headphones or speaker/s, may be capable of producing sound levels that could cause permanent hearing loss. DO NOT operate for long periods of time at a high volume level or at a level that is uncomfortable. If you experience any hearing loss or ringing in the ears, you should consult an audiologist.

IMPORTANT: The louder the sound, the shorter the time period before damage occurs.

NOTICE:

Service charges incurred due to a lack of knowledge relating to how a function or effect works (when the unit is operating as designed) are not covered by the manufacturer's warranty, and are therefore the owners responsibility. Please study this manual carefully and consult your dealer before requesting service.

ENVIRONMENTAL ISSUES:

Yamaha strives to produce products that are both user safe and environmentally friendly. We sincerely believe that our products and the production methods used to produce them, meet these goals. In keeping with both the letter and the spirit of the law, we want you to be aware of the following:

Battery Notice:

This product MAY contain a small non-rechargeable battery which (if applicable) is soldered in place. The average life span of this type of battery is approximately five years. When replacement becomes

necessary, contact a qualified service representative to perform the replacement.

This product may also use "household" type batteries. Some of these may be rechargeable. Make sure that the battery being charged is a rechargeable type and that the charger is intended for the battery being charged.

When installing batteries, do not mix batteries with new, or with batteries of a different type. Batteries MUST be installed correctly. Mismatches or incorrect installation may result in overheating and battery case rupture.

Warning:

Do not attempt to disassemble, or incinerate any battery. Keep all batteries away from children. Dispose of used batteries promptly and as regulated by the laws in your area. Note: Check with any retailer of household type batteries in your area for battery disposal information.

Disposal Notice:

Should this product become damaged beyond repair, or for some reason its useful life is considered to be at an end, please observe all local, state, and federal regulations that relate to the disposal of products that contain lead, batteries, plastics, etc. If your dealer is unable to assist you, please contact Yamaha directly.

NAME PLATE LOCATION:

The name plate is located on the bottom of the product. The model number, serial number, power requirements, etc., are located on this plate. You should record the model number, serial number, and the date of purchase in the spaces provided below and retain this manual as a permanent record of your purchase.

Model _____

Serial No. _____

Purchase Date _____

PLEASE KEEP THIS MANUAL

92-BP (bottom)

FCC INFORMATION (U.S.A.)

1. IMPORTANT NOTICE: DO NOT MODIFY THIS UNIT!

This product, when installed as indicated in the instructions contained in this manual, meets FCC requirements. Modifications not expressly approved by Yamaha may void your authority, granted by the FCC, to use the product.

2. IMPORTANT:

When connecting this product to accessories and/or another product use only high quality shielded cables. Cable/s supplied with this product MUST be used. Follow all installation instructions. Failure to follow instructions could void your FCC authorization to use this product in the USA.

3. NOTE:

This product has been tested and found to comply with the requirements listed in FCC Regulations, Part 15 for Class "B" digital devices. Compliance with these requirements provides a reasonable level of assurance that your use of this product in a residential environment will not result in harmful interference with other electronic devices. This equipment generates/uses radio frequencies and, if not installed and used according to the instructions found in the users manual, may cause interference harmful to the operation of other electronic devices. Compliance with FCC regulations does not

guarantee that interference will not occur in all installations. If this product is found to be the source of interference, which can be determined by turning the unit "OFF" and "ON", please try to eliminate the problem by using one of the following measures:

Relocate either this product or the device that is being affected by the interference.

Utilize power outlets that are on different branch (circuit breaker or fuse) circuits or install AC line filter/s.

In the case of radio or TV interference, relocate/reorient the antenna. If the antenna lead-in is 300 ohm ribbon lead, change the lead-in to coaxial type cable.

If these corrective measures do not produce satisfactory results, please contact the local retailer authorized to distribute this type of product. If you can not locate the appropriate retailer, please contact Yamaha Corporation of America, Electronic Service Division, 6600 Orangethorpe Ave, Buena Park, CA90620

The above statements apply ONLY to those products distributed by Yamaha Corporation of America or its subsidiaries.

* This applies only to products distributed by YAMAHA CORPORATION OF AMERICA.

(class B)

OBSERVERA!

Apparaten kopplas inte ur växelströmskällan (nätet) så länge som den är ansluten till vägguttaget, även om själva apparaten har stängts av.

ADVARSEL: Netspændingen til dette apparat er IKKE afbrudt, så længe netledningen sidder i en stikkontakt, som er t endt — også selvom der er slukket på apparatets afbryder.

VAROITUS: Laitteen toisiopiiriin kytketty käyttökytin ei irroita koko laitetta verkosta.

(standby)

PRECAUTIONS

PLEASE READ CAREFULLY BEFORE PROCEEDING

* Please keep this manual in a safe place for future reference.

WARNING

Always follow the basic precautions listed below to avoid the possibility of serious injury or even death from electrical shock, short-circuiting, damages, fire or other hazards. These precautions include, but are not limited to, the following:

- Do not open the instrument or attempt to disassemble the internal parts or modify them in any way. The instrument contains no user-serviceable parts. If it should appear to be malfunctioning, discontinue use immediately and have it inspected by qualified Yamaha service personnel.
- Do not expose the instrument to rain, use it near water or in damp or wet conditions, or place containers on it containing liquids which might spill into any openings.
- If the AC adaptor cord or plug becomes frayed or damaged, or if there is a sudden loss of sound during use of the instrument, or if any unusual smells or smoke should appear to be caused by it, immediately turn off the power switch, disconnect the adaptor plug from the outlet, and have the instrument inspected by qualified Yamaha service personnel.
- Use the specified adaptor (PA-5C or an equivalent recommended by Yamaha) only. Using the wrong adaptor can result in damage to the instrument or overheating.
- Before cleaning the instrument, always remove the electric plug from the outlet. Never insert or remove an electric plug with wet hands.
- Check the electric plug periodically and remove any dirt or dust which may have accumulated on it.

CAUTION

Always follow the basic precautions listed below to avoid the possibility of physical injury to you or others, or damage to the instrument or other property. These precautions include, but are not limited to, the following:

- Do not place the AC adaptor cord near heat sources such as heaters or radiators, and do not excessively bend or otherwise damage the cord, place heavy objects on it, or place it in a position where anyone could walk on, trip over, or roll anything over it.
- When removing the electric plug from the instrument or an outlet, always hold the plug itself and not the cord.
- Do not connect the instrument to an electrical outlet using a multiple-connector. Doing so can result in lower sound quality, or possibly cause overheating in the outlet.
- Unplug the AC power adaptor when not using the instrument, or during electrical storms.
- Always make sure all batteries are inserted in conformity with the +/- polarity markings. Failure to do so might result in overheating, fire, or battery fluid leakage.
- Always replace all batteries at the same time. Do not use new batteries together with old ones. Also, do not mix battery types, such as alkaline batteries with manganese batteries, or batteries from different makers, or different types of batteries from the same maker, since this can cause overheating, fire, or battery fluid leakage.
- Do not dispose of batteries in fire.
- Do not attempt to recharge batteries that are not intended to be charged.
- When the batteries run out, or if the instrument is not to be used for a long time, remove the batteries from the instrument to prevent possible leakage of the battery fluid.
- Keep batteries away from children.
- If the batteries do leak, avoid contact with the leaked fluid. If the battery fluid should come in contact with your eyes, mouth, or skin, wash immediately with water and consult a doctor. Battery fluid is corrosive and may possibly cause loss of sight or chemical burns.
- Before connecting the instrument to other electronic components, turn off the power for all components. Before turning the power on or off for all components, set all volume levels to minimum. Also, be sure to set the volumes of all components at their minimum levels and gradually raise the volume controls while playing the instrument to set the desired listening level.
- Do not expose the instrument to excessive dust or vibrations, or extreme cold or heat (such as in direct sunlight, near a heater, or in a car during the day) to prevent the possibility of panel disfiguration or damage to the internal components.
- Do not use the instrument near other electrical products such as televisions, radios, or speakers, since this might cause interference which can affect proper operation of the other products.
- Do not place the instrument in an unstable position where it might accidentally fall over.
- Before moving the instrument, remove all connected adaptor and other cables.
- When cleaning the instrument, use a soft, dry cloth. Do not use paint thinners, solvents, cleaning fluids, or chemical-impregnated wiping cloths. Also, do not place vinyl, plastic or rubber objects on the instrument, since this might discolor the panel or keyboard.
- Do not rest your weight on, or place heavy objects on the instrument, and do not use excessive force on the buttons, switches or connectors.
- Use only the stand specified for the instrument. When attaching the stand, use the provided screws only. Failure to do so could cause damage to the internal components or result in the instrument falling over.
- Do not operate the instrument for a long period of time at a high or uncomfortable volume level, since this can cause permanent hearing loss. If you experience any hearing loss or ringing in the ears, consult a physician.
- Playing while looking at the lights for a long period of time may cause eye strain and stiff neck/shoulders. For your health and comfort, we recommend that you take a ten-minute break for every hour.

■ DATA BACK-UP AND STORAGE

- Yamaha recommends that you regularly save data using an external device such as the floppy disk-based Yamaha MIDI data filer MDF3, and storing the floppy disks in a safe, cool, dry place. **YAMAHA CANNOT BE HELD RESPONSIBLE FOR THE ACCIDENTAL LOSS OF IMPORTANT MUSIC DATA!** Regarding the data you have created, as long as fresh batteries are inserted in (or an AC power adaptor is connected to) the instrument, the data will be retained, even when the power is turned off. It will also be retained long enough to exchange an old set of batteries for a new set. If you have important data in the instrument which you don't want to lose, please take care to keep fresh batteries inserted in (or keep an AC power adaptor connected to) the instrument, and to regularly save data.

Yamaha cannot be held responsible for damage caused by improper use or modifications to the instrument, or data that is lost or destroyed.

Always turn the power off when the instrument is not in use.
Make sure to discard used batteries according to local regulations.

Congratulations on your purchase of the Yamaha EZ-30 PortaTone!

You now own a portable keyboard that combines advanced functions, great sound and exceptional ease-of-use in a highly compact package. Its outstanding features also make it a remarkably expressive and versatile instrument.

Read this Owner's Manual carefully while playing your new EZ-30 in order to take full advantage of its various features.

Main Features

The EZ-30 is a sophisticated yet easy-to-use keyboard with the following features and functions:



Yamaha Education Suite

The EZ-30 features the new Yamaha Education Suite - a set of learning tools that utilize the latest technology to make studying and practicing music more fun and fulfilling than ever before!

The Yamaha Education Suite includes:

- **Lesson page 34**
The convenient and easy-to-use Lesson feature guides you through the parts of a song - just like a patient teacher! Select from any one of 100 songs on the EZ-30, and learn the left- and right-hand parts independently at first, then together. Lesson features three easy steps that help you master each song: Timing, Waiting and Minus One.
- **Grade & Talking pages 37 and 38**
The EZ-30 also has the Grade and Talking features. Grade is a virtual "teacher," evaluating your practice sessions and rating your performance. The convenient Talking function "announces" each Lesson step and your "grades," among other things.
- **Dictionary page 58**
Dictionary is a built-in "chord encyclopedia" that teaches you how to play specific chords by showing you the appropriate notes in the display - perfect for when you know the name of a chord and want to quickly learn how to play it!
- **Lighting page 32**
When you are using the Lesson feature or Dictionary, the key indicators tell you which keys to play. Also, during song playback, they show the keys that are playing.
- **ABC/DoReMi..... page 43**
The EZ-30 sings the melody using "A, B, C..." or "DoReMi." Also, while you are using the Lesson function, the EZ-30 guides you by singing a note ahead using "A, B, C" or "DoReMi."



Portable Grand page 39

The EZ-30 also has a Portable Grand function for realistic piano performance. Pressing the [PORTABLE GRAND] button instantly calls up the stunningly authentic “Stereo Sampled Piano” voice and configures the entire EZ-30 for optimum piano play. Special Pianist styles and songs - with piano-only accompaniment - are also provided.

Flash Memory page 71

The EZ-30, when connected to a personal computer, can load song data (purchased via internet) into the internal flash memory. You can use this song data along with the Lesson function. Also, the song data will be retained, even when the AC power adaptor and batteries are removed from the EZ-30.

Other powerful features include:

- ◆ 61 keys with a **Touch Response** mechanism that enables you to express subtle nuances through various playing techniques.
- ◆ A total of **610 various high-quality voices** (including 480 Expanded voices), with a maximum polyphony of 32 voices.
- ◆ High-quality **Reverb, DSP, and Harmony effects** for enhancing the sound of the voices - and your performance.
- ◆ **106 auto accompaniment styles**, each with Intro, Main A and B, and Ending sections. An Auto Fill function adds dynamic fills when switching sections.
- ◆ Powerful, easy-to-use **song recording** operations, for recording and playing back up to five of your original songs.
- ◆ **Registration Memory** presets for storing all of the EZ-30’s panel settings to a single button for instant and automatic recall.
- ◆ **One Touch Setting** function for automatically calling up an appropriate voice to match the style or song you select.
- ◆ Full MIDI and **General MIDI (GM) compatibility**, letting you easily integrate the EZ-30 into a MIDI music system, and use the built-in Expanded voices with all GM software.

* The illustrations and LCD screens as shown in this owner’s manual are for instructional purposes only, and may be different from the ones on your instrument.

Contents

Setting Up8

- Power Requirements 8
- Using Headphones..... 9
- Connecting a Keyboard Amplifier or Stereo System..... 9
- Using a Footswitch..... 9
- Using the MIDI Terminals 9

Panel Controls and Terminals.10

Quick Guide 12

Songs 12

- Playing the Demo Songs..... 12
- Playing a Single Song 13

Lesson 14

- Using the Lesson Feature..... 14

Voices 16

- Playing the Piano 16
- Playing along with the Metronome 16
- Playing the ABC/DoReMi voices. 17
- Selecting and Playing Other Voices 17

Auto Accompaniment 18

- Using the Auto Accompaniment 18
- Looking up Chords in the Dictionary 20

Panel Display Indications22

Selecting and Playing Songs ...28

- Listening To a Demo Song 28
- Selecting and Playing a Song 28
- Listening to a Flash Song..... 29
- Switching the Tracks On and Off 29
 - Melody Voice Change..... 30
- Adjusting the Tempo 31
 - Tap Function 31
- Song Volume Level 32
- Switching the Light Guide On and Off 32

Song Lesson34

- Using the Lesson Feature 34
- ABC/DoReMi Guide..... 36
- Grade 37
- Talking 38

Portable Grand.....39

- Using the Metronome..... 39
 - Setting a Tempo..... 39
 - Setting the Time Signature of the Metronome..... 40
 - Adjusting the Metronome Volume..... 40

Playing Voices42

- Selecting a Voice 42
- Playing a Voice 42
- One Touch Setting 43
- Changing the Split Point..... 44
- Transpose 45
- Tuning 46
- Touch 47
- Touch Sensitivity 47

Effects48

- Reverb..... 48
- DSP 49
- Harmony..... 50

Auto Accompaniment51

- Selecting a Style 51
- Starting Accompaniment 52
 - Sync start..... 52
 - Start..... 53
 - Tap start 53
- Stopping the Accompaniment... 54
- Changing the Tempo 54
- Using Auto Accompaniment—
Multi Fingering..... 55
 - Single Finger Chords..... 55
 - Fingered Chords 56

Looking up Chords in the dictionary.....	58	Troubleshooting.....	83
Playing a Melody along with the Accompaniment.....	61	Data Backup & Initialization..	84
Adjusting the Accompaniment Volume.....	61	Data Backup	84
Ending.....	63	Data Initialization	84
Changing the Accompaniment Section	62	Voice List	85
Intro.....	62	Style List	90
Main.....	62	Drum Kit List	91
Ending.....	63	Effect Type List	96
Registration Memory	64	MIDI Implementation Chart... ..	98
Recording a Registration Memory Preset.....	64	Specifications	102
Recalling a Registration Memory Preset.....	65	Index.....	103
Song Recording	66		
Recording a User Song.....	66		
Erasing a Song.....	69		
Song Clear.....	69		
Track Clear.....	70		
Loading a Song into Flash Memory	71		
Installing Song Filer.....	71		
Song Filer's Functions.....	72		
Octave.....	73		
Available Flash Memory Amount	74		
Flash Clear	74		
MIDI Functions.....	75		
What is MIDI?.....	75		
Available MIDI Functions.....	77		
Connecting to a Personal Computer	78		
Local Control	79		
Using Bulk Dump Send to Save Data	80		
Transmitting the EZ-30 Panel Settings (Initial Send)	81		
Transmitting SMF Format Data..	82		

Setting Up

Power Requirements

Although the EZ-30 will run either from an optional AC adaptor or batteries, Yamaha recommends use of an AC adaptor whenever possible. An AC adaptor is more environmentally friendly than batteries and does not deplete resources.

■ Using an AC Power Adaptor

Use of an AC power adaptor is recommended, especially when you use the EZ-30 for a long period of time.

- ① Make sure that the [STANDBY/ON] switch of the EZ-30 is set to STANDBY.
- ② Connect one end of the adaptor to the **DC IN 10-12V** jack on the rear panel of your EZ-30.
- ③ Connect the other end to a suitable electrical outlet.

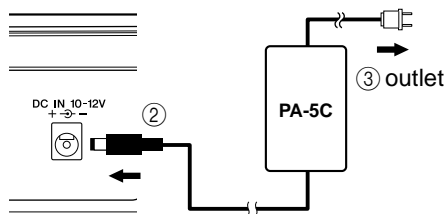

⚠ WARNING

Use **ONLY** a Yamaha PA-5C AC Power Adaptor (or other adaptor specifically recommended by Yamaha) to power your instrument from the AC mains. The use of other adaptors may result in irreparable damage to both the adaptor and the EZ-30.

⚠ CAUTION

Unplug the AC Power Adaptor when not using the EZ-30, or during electrical storms.

■ Using Batteries

- ① Turn the instrument upside-down and remove the battery compartment lid.

- ② Insert six 1.5-volt “D” size, R20P (LR20) or equivalent batteries as shown in the illustration, making sure that the positive and negative terminals are properly aligned.
- ③ Replace the lid.

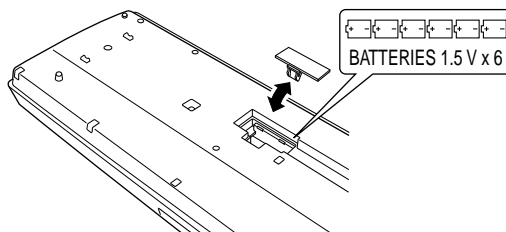

Replace the batteries before they completely discharge. If the battery voltage gets low, the volume level may be reduced, sound integrity may deteriorate, the display indicators may disappear, or the stored data may be deleted. If any of these events occur, replace the battery, heeding the cautions described below.

⚠ CAUTION

- Insert the batteries in the correct direction, making sure that the positive and negative terminals of the batteries match the label. If the orientation does not match the label, the batteries may generate heat, cause a fire, or leak.
- Never mix old and new batteries or different types of batteries (e.g., alkaline and manganese).
- To prevent possible damage from battery leakage, remove the batteries from the instrument if it is not to be used for a long time.
- Even when the switch is in the “STANDBY” position, electricity is still flowing to the instrument at the minimum level. When you plan not to use the EZ-30 for a long period of time, make sure you unplug the AC power adaptor from the wall AC outlet, and/or remove the batteries from the instrument.

Using Headphones

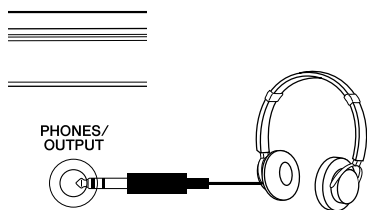

For private practicing and playing without disturbing others, connect a set of stereo headphones to the rear panel PHONES/OUTPUT jack. Sound from the built-in speaker system is automatically cut off when you insert a headphone plug into this jack.

CAUTION

Do not use headphones for a long time at high volume levels. Otherwise, you may damage your hearing.

Connecting a Keyboard Amplifier or Stereo System

Though the EZ-30 is equipped with a built-in speaker system, you can also play it through an external amplifier/speaker system. First, make sure the EZ-30 and any external devices are turned off, then connect one end of a stereo audio cable to the LINE IN or AUX IN jack(s) of the other device and the other end to the rear panel PHONES/OUTPUT jack on the EZ-30.

CAUTION

To prevent damage to the speakers, set the volume of the external devices at the minimum setting before connecting them. Failure to observe these cautions may result in electric shock or equipment damage. Also, be sure to set the volumes of all devices at their minimum levels and gradually raise the volume controls while playing the instrument to set the desired listening level.

Using a Footswitch

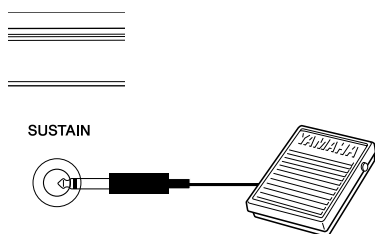

This feature lets you use an optional footswitch (Yamaha FC4 or FC5) to sustain the sound of the voices. The footswitch functions the same way as a damper pedal on an acoustic piano - press and hold down the footswitch as you play the keyboard to sustain the sound.



Note

- Make sure that the footswitch plug is properly connected to the SUSTAIN jack before you turn on the power.
- Do not press the footswitch while turning the power on. Doing this changes the recognized polarity of the footswitch, resulting in reversed footswitch operation.

Using the MIDI Terminals

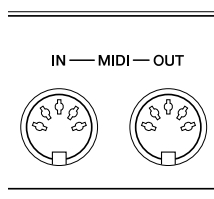

The EZ-30 also features MIDI terminals, allowing you to interface the EZ-30 with other MIDI instruments and devices. (For more information, see page 78.)



Note

- Special MIDI cables (sold separately) must be used for connecting to MIDI devices. They can be bought at music stores, etc.
- Never use MIDI cables longer than about 15 meters. Cables longer than this can pick up noise which can cause data errors.

Music Stand

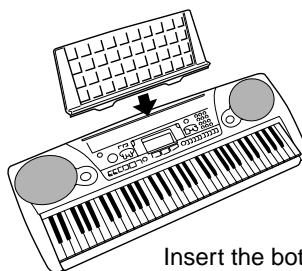

Insert the bottom edge of the included music stand into the slot located at the top rear of the EZ-30 control panel.

Panel Controls and Terminals

Front Panel

- ❶ Power switch ([STANDBY/ON])..... 22
- ❷ [MASTER VOLUME] dial..... 22
- ❸ [DEMO] button..... 28
- ❹ [TOUCH] button..... 47
- ❺ [Dict.] (DICTIONARY) button 58
- ❻ LESSON [L] (Left) and [R] (Right) buttons34
- ❼ Overall (left, right) buttons 23
- ❽ [TEMPO/TAP] button..... 31
- ❾ [PORTABLE GRAND] button 39
- ❿ [METRONOME] button..... 39
- ⓫ [ABC/DoReMi] button 43
- ⓬ Numeric keypad, [+ /YES] and [- /NO] buttons..... 25
- ⓭ [ACMP ON/OFF] / [GRADE ON/OFF] button 52, 37
- ⓮ [REW] button 29
- ⓯ [SYNC STOP] / [FF] button..... 52, 29
- ⓰ [SYNC START] / [LESSON 1] button52, 35
- ⓱ [INTRO/ENDING] / [LESSON 2] button 62, 35
- ⓲ [MAIN/AUTO FILL] / [LESSON 3] button..... 62, 35
- ⓳ [STYLE] button 51
- ⓴ [SONG] button 28
- ⓴ [START/STOP] button 29
- ⓴ [VOICE] button..... 42
- ⓴ [RECORD] button 67
- ⓴ SONG MEMORY buttons..... 67
- ⓴ REGISTRATION MEMORY buttons 64

Rear Panel

- ⓶ MIDI IN,OUT terminals 9
- ⓷ SUSTAIN jack 9
- ⓸ PHONES/OUTPUT jack..... 9
- ⓹ DC IN 10-12V jack 8

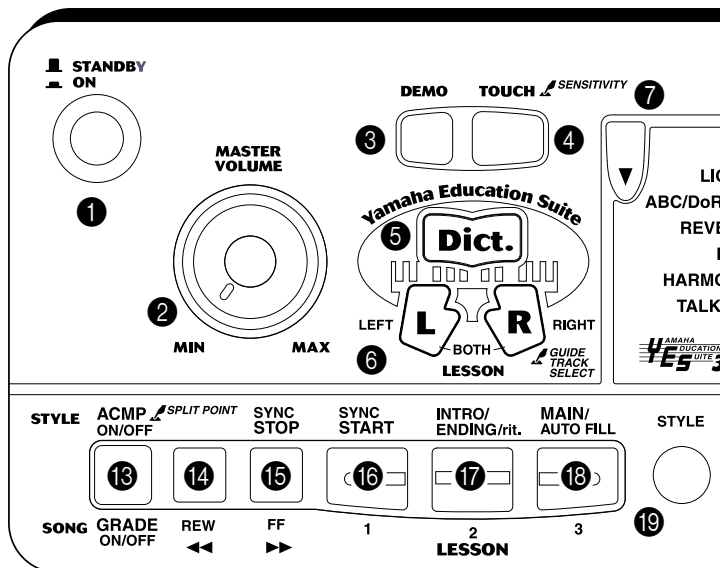



▲...PRESS AND HOLD FOR A WHILE.

LIGHT
oReMi
EYEB
DSP
MONY
LKLING

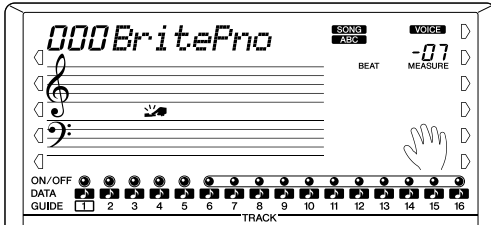

OCTAVE
TRANSPOSE
TUNING
ACMP/SONG
METRONOME
VOLUME
MIDI

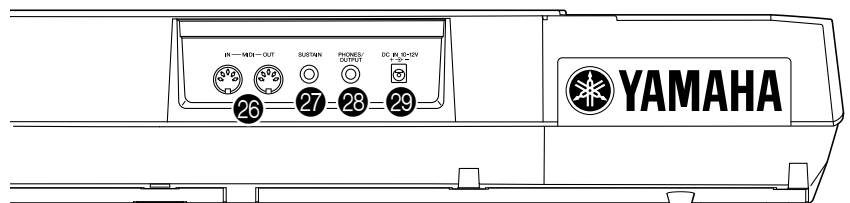
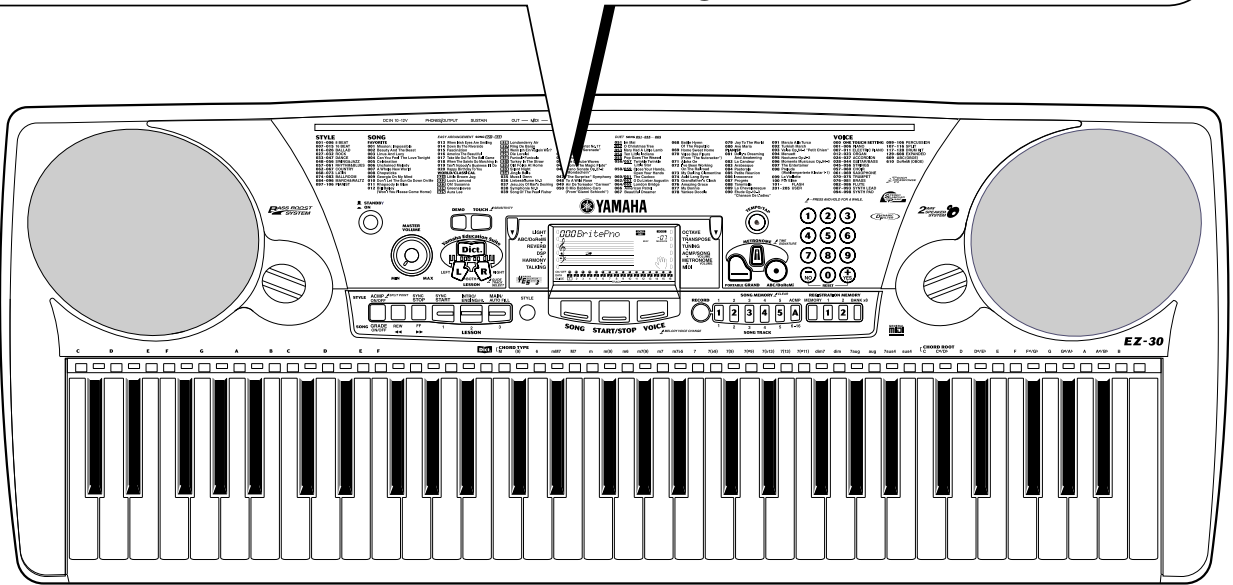
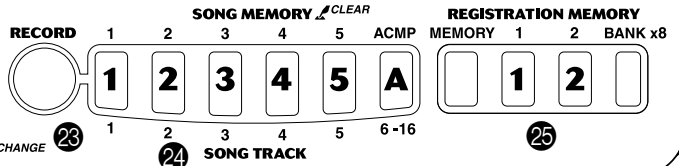
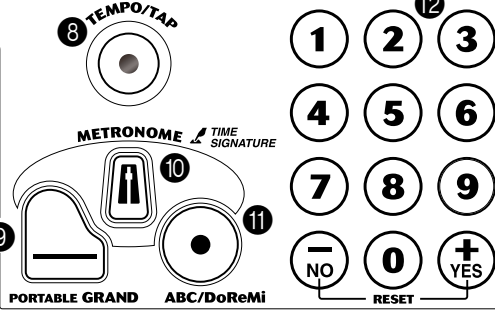

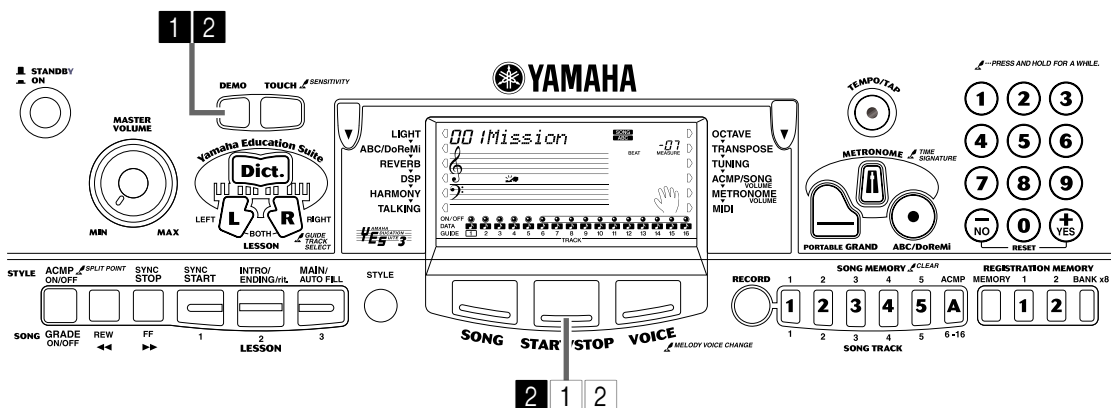

Playing the Demo Songs

Demo songs (001–100) showcase the sophisticated features and stunning sound of the EZ-30. Let's play the Demo songs now, starting with 001...

1 Press the [DEMO] button.

Demo song 001 starts playing. When the song is complete, the subsequent songs (002, 003...) start playing sequentially.



Note If you have loaded songs into flash memory, they are the first to play.

2 Stop the Demo song.

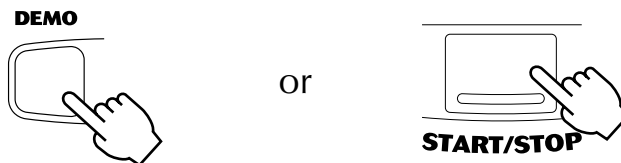

* Want to find out more? See page 28.



Note If you do not wish to play the Demo songs when you press the [DEMO] button, turn on the power to the EZ-30 while pressing and holding down the [DEMO] button. To activate the Demo playback function, turn on the power to the EZ-30 in the normal manner.

Playing a Single Song

Naturally, you can also individually select and play back any of the EZ-30's songs (Songs 001–100 and songs in flash memory). Also, simply by pressing the [START/STOP] button, you can start playback.

1 Start the song.

When the power of the EZ-30 is turned on, the song of "003: Linus And Lucy" is selected. For instructions on selecting songs, See page 28.

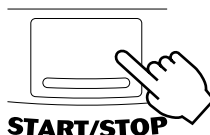

2 Stop the song.

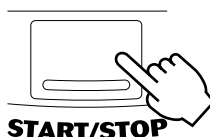

* Want to find out more? See page 28.

[Song List]

No.	Song Name	No.	Song Name	No.	Song Name	No.	Song Name
Favorite		25	Aura Lee	52	O Christmas Tree (DUET)	77	My Bonnie
1	Mission:Impossible	26	Londonderry Air	53	Mary Had A Little Lamb (DUET)	78	Yankee Doodle
2	Beauty And The Beast	27	Ring De Banjo	54	Ten Little Indians (DUET)	79	Joy To The World
3	Linus And Lucy	28	Wenn Ich Ein Vöglein Wär ?	55	Pop Goes The Weasel (DUET)	80	Ave Maria
4	Can You Feel The Love Tonight	29	Die Lorelei	56	Twinkle Twinkle Little Star	Pianist	
5	Celebration	30	Funiculi-Funicula	57	Twinkle Twinkle Little Star (DUET)	81	Dolly's Dreaming And Awakening
6	Unchained Melody	31	Turkey In The Straw	58	Close Your Hands, Open Your Hands	82	La Candeur
7	A Whole New World	32	Old Folks At Home	59	Close Your Hands, Open Your Hands (DUET)	83	Arabesque
8	Chopsticks	33	Silent Night	60	The Cuckoo	84	Pastorale
9	Georgia On My Mind	34	Jingle Bells	61	The Cuckoo (DUET)	85	Petite Réunion
10	Don't Let The Sun Go Down On Me	35	Muss I Denn	62	O Du Lieber Augustin	86	Innocence
11	Rhapsody In Blue	36	Liebesträume Nr.3	63	O Du Lieber Augustin (DUET)	87	Progrès
12	Bill Bailey (Won't You Please Come Home)	37	Jesu, Joy Of Man's Desiring	64	London Bridge	88	Tarentelle
13	When Irish Eyes Are Smiling	38	Symphonie Nr.9	65	London Bridge (DUET)	89	La Chevaleresque
14	Down By The Riverside	39	Song Of The Pearl Fisher	66	American Patrol	90	Etude Op.10-3 "Chanson De L'adieu"
15	Fascination	40	Gavotte	67	Beautiful Dreamer	91	Marcia Alla Turca
16	America The Beautiful	41	String Quartet No.17 2nd Mov. "Serenade"	68	Battle Hymn Of The Republic	92	Turkish March
17	Take Me Out To The Ball Game	42	Menuett	69	Home Sweet Home	93	Valse Op.64-1 "Peiti Chien"
18	When The Saints Go Marchin' In	43	Canon	70	Valse Des Fleurs (From "The Nutcracker")	94	Menuett
19	Tain't Nobody's Business If I Do	44	The Danube Waves	71	Aloha Oe	95	Nocturne Op.9-2
20	Happy Birthday To You	45	From "The Magic Flute"	72	I've Been Working On The Railroad	96	Moments Musicaux Op.94-3
World/Classic		46	Piano Sonate Op.27-2 "Mondschein"	73	My Darling Clementine	97	The Entertainer
21	Little Brown Jug	47	"The Surprise" Symphony	74	Auld Lang Syne	98	Prelude (Wohltemperierte Klavier 1-1)
22	Loch Lomond	48	To A Wild Rose	75	Grandfather's Clock	99	La Violette
23	Oh! Susanna	49	Air de "Toréador" Carmen"	76	Amazing Grace	100	Für Elise
24	Greensleeves	50	O Mio Babbino Caro (From "Gianni Schicchi")				
		51	Im Mai (DUET)				

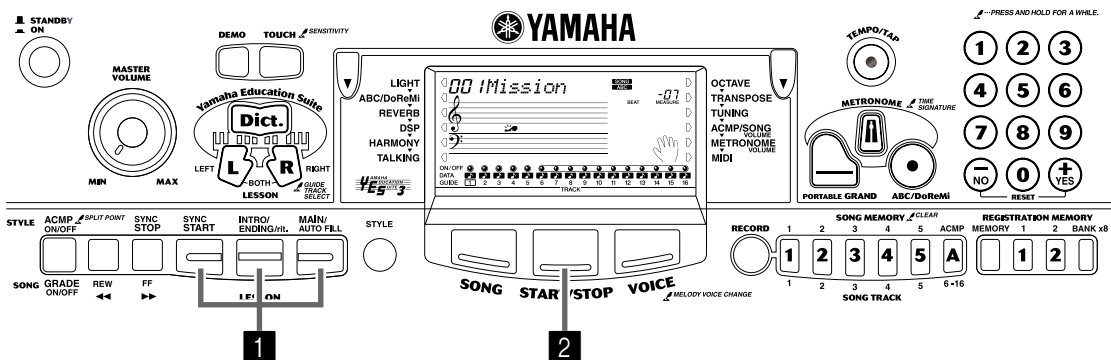

Using the Lesson Feature

Songs 001 to 100 are specially designed for use with the educational Lesson feature. Let's start the practice, following the light.

1 Select Timing, Waiting, or Minus One, and start the lesson.

When the power of the EZ-30 is turned on, the song of "003: Linus And Lucy" and the right-hand part are selected.

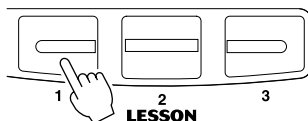

Lesson 1: Timing

This step lets you work on the timing of the notes. In Lesson 1, the particular note you play on the keyboard is unimportant. The EZ-30 checks your timing and how rhythmically "tight" your playing is.

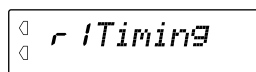
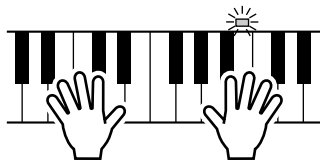

Lesson 2: Waiting

In Lesson 2, you practice playing the notes correctly as they appear in the display notation. The accompaniment pauses and waits for you to play the notes correctly before it continues.

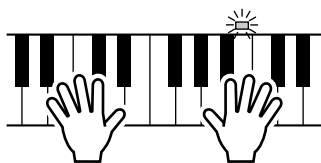

```
r2Waiting
```

Lesson 3: Minus One

In Lesson 3, you practice playing correct notes, along with the accompaniment. The accompaniment continues playing in tempo.

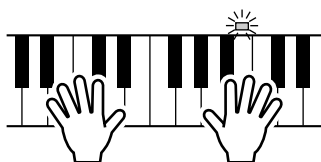

```
r3MinusOne
```

2 When you're finished, stop the Lesson.

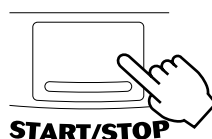

* Want to find out more? See page 34.

Grade

The EZ-30 has a built-in evaluation function that monitors your practicing and - like a real teacher - tells you how well you did each practice. Four grades are assigned, depending on your performance: "Try Again," "Good," "Very Good," and "Excellent."

* Want to find out more? See page 37.

Talking

This feature "talks" to you through the speakers, "announcing" the Grade comments as well as the titles of the Lesson steps.

* Want to find out more? See page 38.

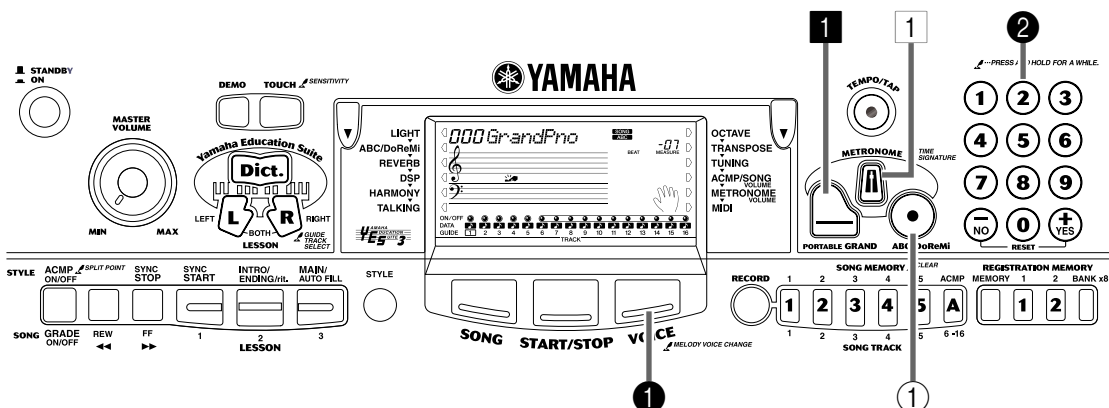

Playing the Piano

Simply by pressing the [PORTABLE GRAND] button, you can automatically reset the entire EZ-30 for piano play.

- 1 Press the [PORTABLE GRAND] button.

The song and style are also set for piano performance.

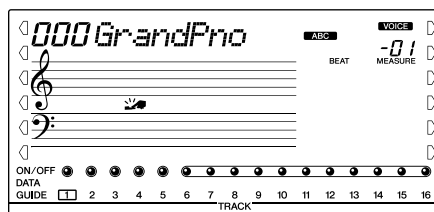

- 2 Play the keyboard.

* Want to find out more? See page 39.

Playing along with the Metronome

- 1 Press the [METRONOME] button.



* Want to find out more? See page 39.

Playing the ABC/DoReMi voices

① Press the [ABC/DoReMi] button.

The ABC voice is selected. To select the DoReMi voice, press the [ABC/DoReMi] again.

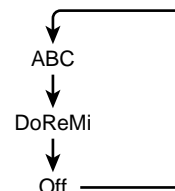
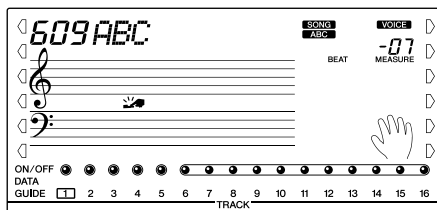

② Play the keyboard.

* Want to find out more? See page 43.

Selecting and Playing Other Voices

The EZ-30 has a huge total of 610 dynamic and realistic instrument voices. Let's try a few of them out now...

① Press the [VOICE] button.

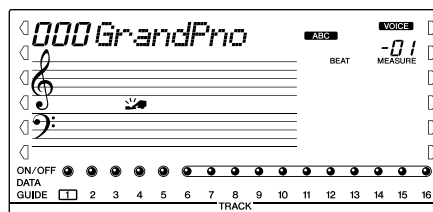
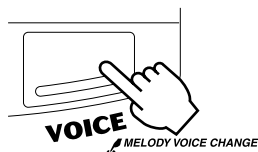

② Select a voice.

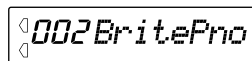
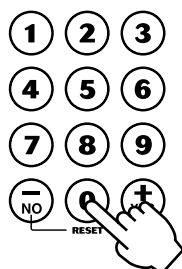

③ Play the keyboard.

* Want to find out more? See page 42.

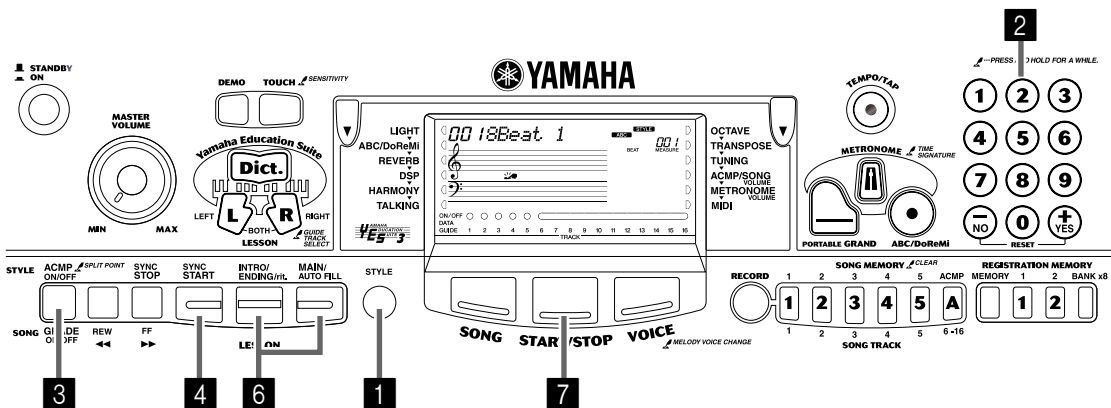

Using the Auto Accompaniment

Simply play chords with your left hand - and the EZ-30 automatically produces appropriate bass, chord and rhythm backing. Use your right hand to play melodies, and you'll sound like an entire band!

Note For more information on playing proper chords for the auto accompaniment, see "Using Auto Accompaniment - Multi Fingering" on page 55 and "Looking up Chords in the dictionary" on page 58.

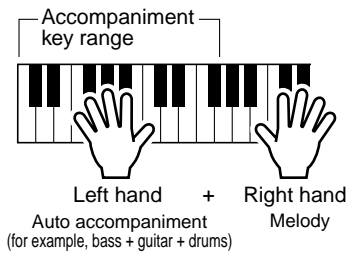

1 Press the [STYLE] button.

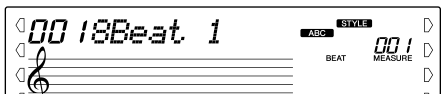
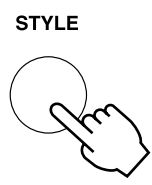

2 Select a style. Refer to the Style List on page 90.

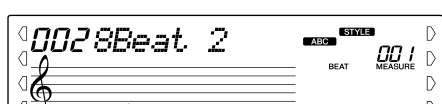
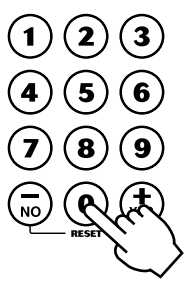

3 Turn the auto accompaniment on.

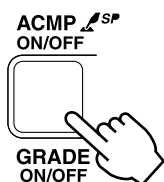

4 Turn the Sync Start function on.

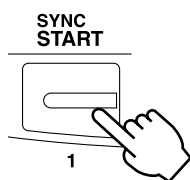

5 Play a chord with your left hand.

The auto accompaniment starts as soon as you play the keyboard.

* Want to find out more? See page 55.

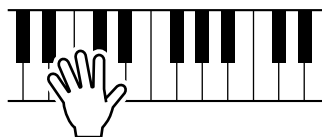

6 Select a section.

The auto accompaniment has four sections: Intro, Main A/B, and Ending.

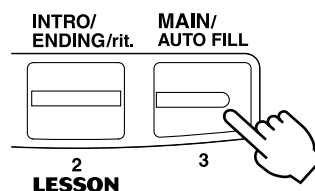

7 Stop the auto accompaniment.

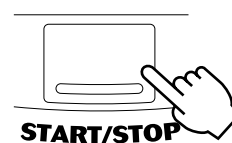

* Want to find out more? See page 51.

Quick Guide **STEP 4** Auto Accompaniment

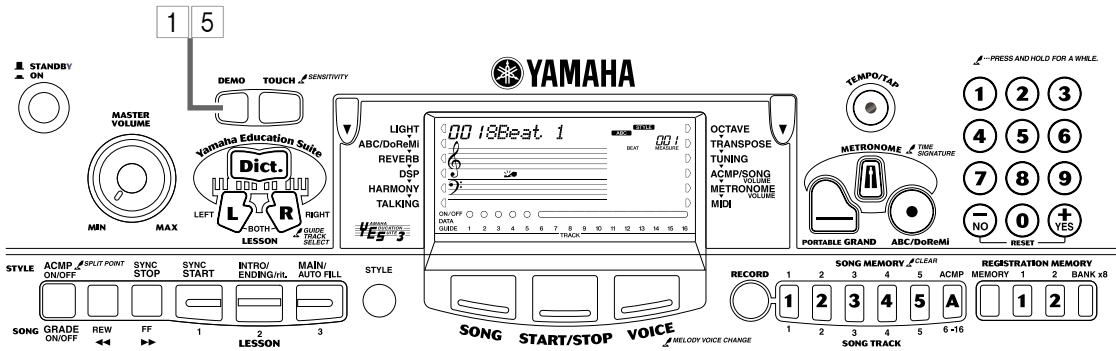

Looking up Chords in the Dictionary

The convenient Dictionary function teaches you how to play chords by showing you the individual notes. In the example below, we'll learn how to play a GM7 chord...

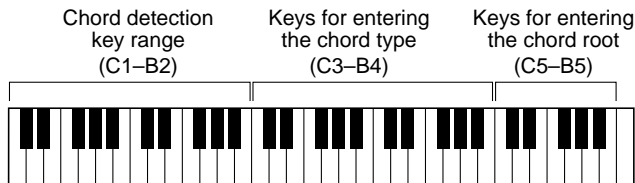

Example:

G	M7
Root note	Chord type

1 Press the [Dict.] button.

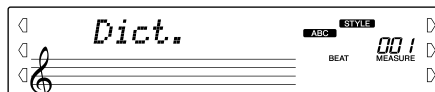

- 2 Specify the root note of the chord (in this case, G).

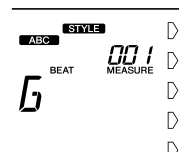
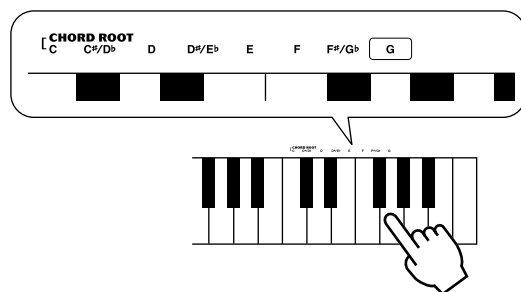

- 3 Specify the chord type of the chord (in this case, M7).

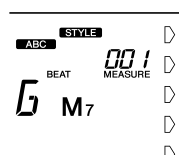
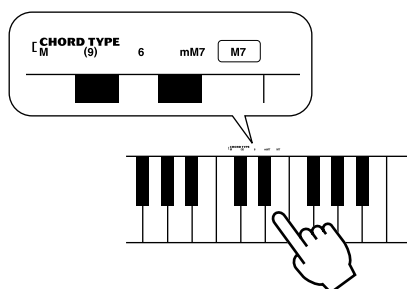

- 4 Play the chord by pressing the keys lighted up.

The chord name flashes and a "congratulations" melody is played, when the chord is played properly.

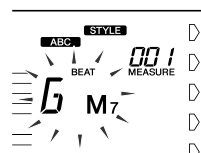
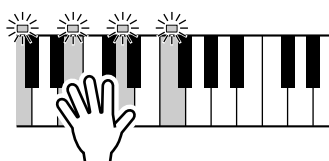

- 5 To leave the Dictionary function, press the [Dict.] button again.



* Want to find out more? See page 58.

Panel Display Indications

Power on

Press the [STANDBY/ON] switch to turn on the power to the EZ-30. Press the [STANDBY/ON] switch again to turn off the power.



Even when the [STANDBY/ON] switch is in the "STANDBY" position, electricity still flows through the instrument at the minimum level. When you plan not to use the EZ-30 for a long period of time, make sure you unplug the AC power adaptor from the wall AC outlet, and/or remove the batteries from the instrument.

Adjusting the volume level

Rotate the [MASTER VOLUME] dial.

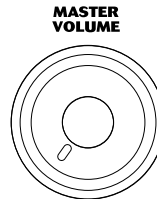

Rotating the dial counter-clockwise lowers the volume level.

Rotating the dial clockwise raises the volume level.

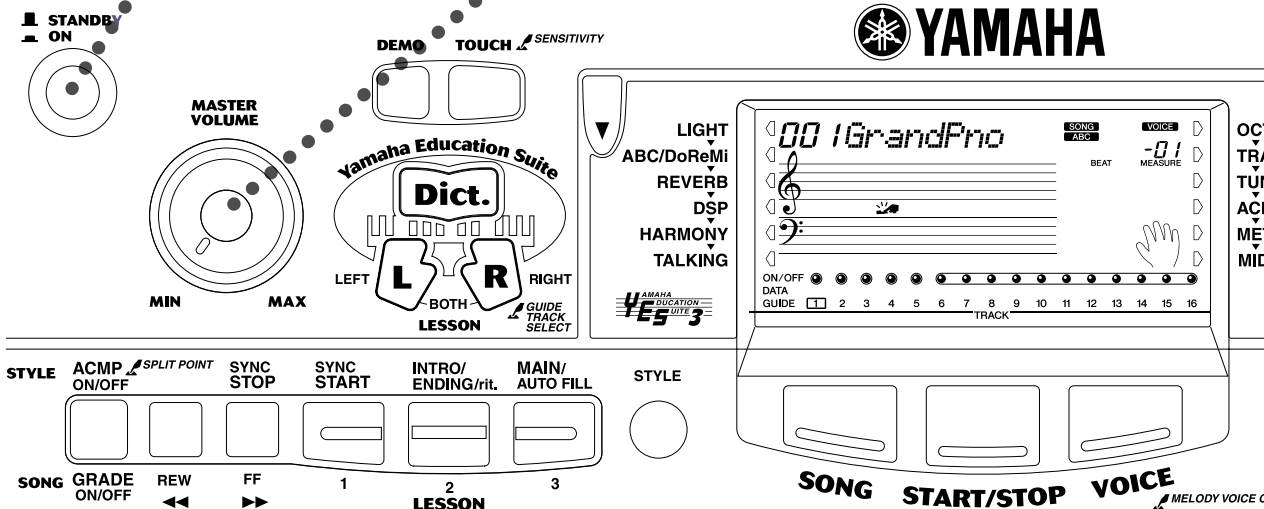

Overall (L, R) indicator

The left and right Overall buttons enable you to make EZ-30's global settings.

Overall (left)

LIGHT	32
ABC/DoReMi	36
REVERB	48
DSP	49
HARMONY	50
TALKING	38

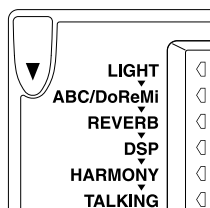

Overall (right)

OCTAVE	73
TRANPOSE	45
TUNING	46
ACMP/SONG VOLUME	61, 32
METRONOME VOLUME	40
MIDI	74, 79

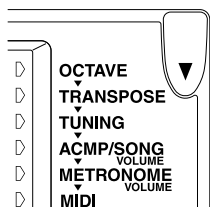

If you press the left or right Overall button located in the upper-left and upper-right of the display, a menu icon advances and the top row in the display indicates the currently-selected "setting item" and "value." When you press the left or right Overall button again, the menu icon advances to the next setting item.

E.g., Transpose setting

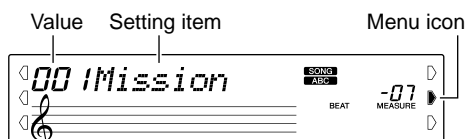

Adjusting the tempo

Song and accompaniment tempo can be adjusted (page 31).

Changing the value

Use the numeric keypad [0]–[9], [+], or [-] buttons to change the value.

Pressing the button once decrements the value by one.

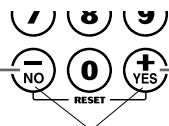

Pressing the button once increments the value by one.

Pressing and holding down the button increments/decrements the value continuously. For some functions, pressing these buttons simultaneously restores the default setting.

Symbol for pressing and holding down the button

If you press and hold down a button with this symbol for more than one second, a different function will be activated.

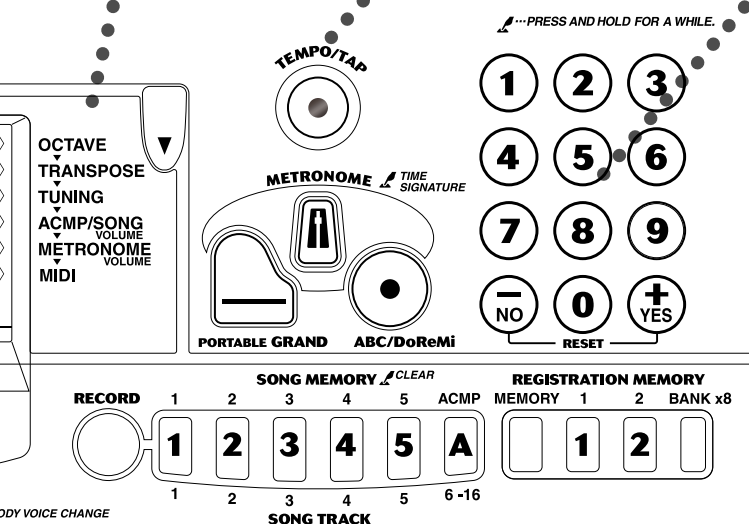

Pressing and holding down



Panel Display Indications

Selecting a function

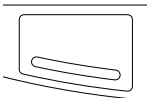
- Pressing the [STYLE], [VOICE], or [SONG] button enables you to select one of EZ-30's basic functions. (The icon of the selected function appears.)

 STYLE	 SONG	 VOICE
<p><u>Style</u></p> <p>Select a style for accompaniment.</p> <p>STYLE</p>	<p><u>Song</u></p> <p>Selects a song for playback or practice.</p> <p>SONG</p>	<p><u>Voice</u></p> <p>Selects a voice to play on the keyboard.</p> <p>VOICE</p>

- If you select a song or accompaniment, then select a voice, the EZ-30 indicates the following:

[Song→Voice]
Select a voice using the numeric keypad.

SONG VOICE

Press the [START/STOP] button to start the song.

[Style→Voice]
Select a voice using the numeric keypad.

STYLE VOICE

Press the [START/STOP] button to start the accompaniment.

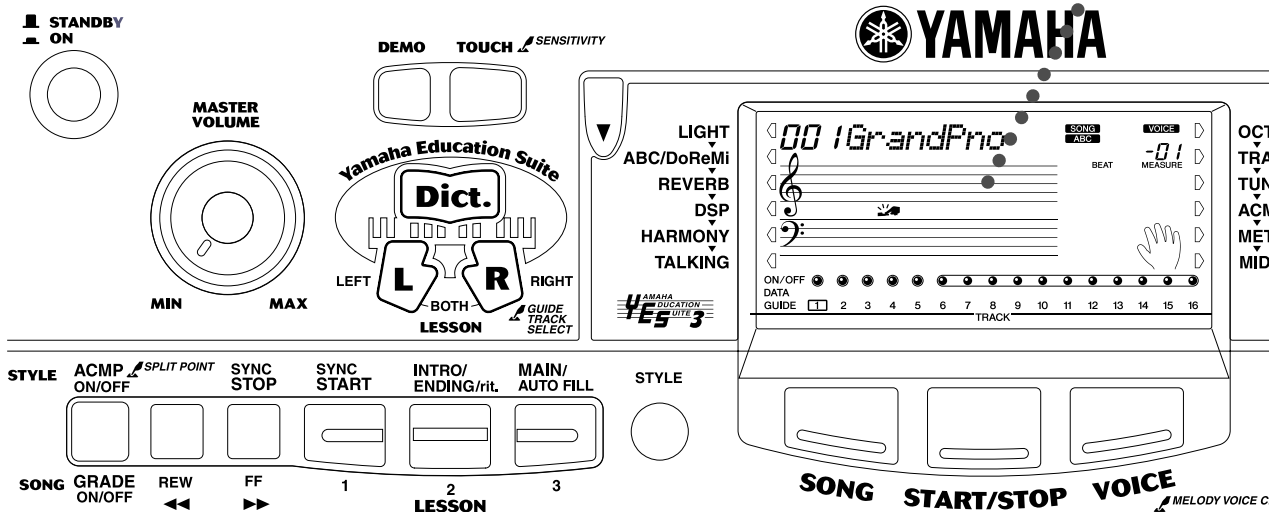

Name & number indication (Song/Style/Voice)

The top row of the display indicates the name and number of the currently-selected function.

E.g., Selecting a song

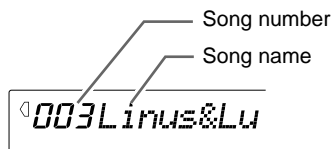

Selecting a number

- To increment or decrement the number, use the numeric keypad or [+]/[-] button.

Pressing the button once decrements the number by one.

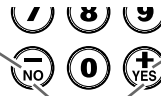

Pressing the button once increments the number by one.

Pressing and holding down the button increments/decrements the number continuously. Pressing both buttons simultaneously resets the number.

- To select the number directly, use the numeric keypad [0]–[9].

For example, to select Voice #005: HnkyTonk, press [0], [0], then [5] on the numeric keypad.

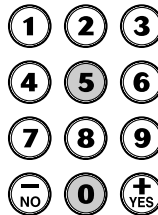

005 HnkyTonk



Note If the first digit is "0," you can skip pressing [0]. If the first and second digits are both "0," you can also skip pressing [0] twice.

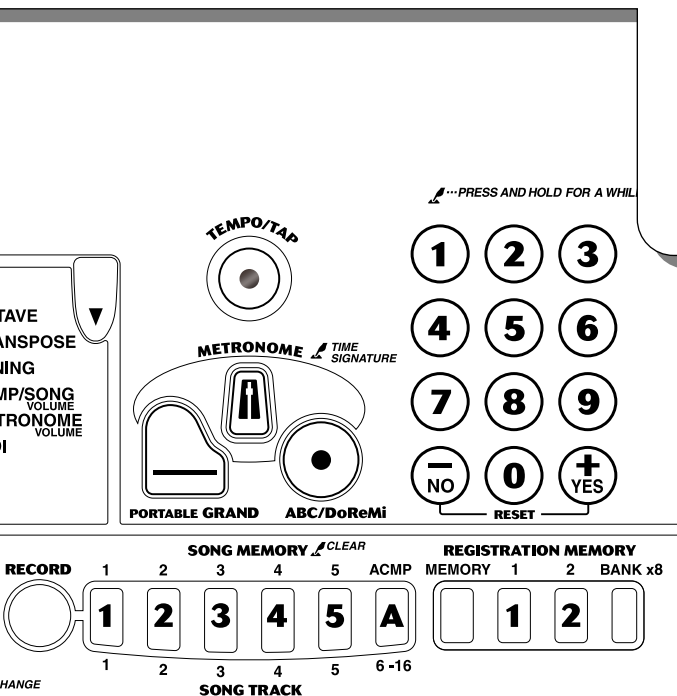

Panel Display Indications

Touch indicator

This appears when the Touch function is turned on.



Sync Stop indicator

This appears when the Sync Stop function is turned on.



Harmony indicator

This appears when the Harmony effect is turned on.



Accompaniment On indicator

This appears when the auto accompaniment has been turned on.



ABC/DoReMi indicators

These show the guide voice setting ("ABC" or "DoReMi") for the Lesson function.

ABC

Low battery indicator

This appears when the battery voltage is getting low.



Song track ON/OFF indicators

They light up when the corresponding tracks are turned on.



Song track DATA indicators

They indicate the current playback tracks.



Song track GUIDE indicators

A frame appears around the number of a track that uses the right-hand/left-hand guide function.



Notation display

When you are using the Lesson function, the notation display indicates the song melody or chord notation. When you are using the Dictionary function, it indicates the notes that make up the chord. Other than that, it usually indicates the notes you played.

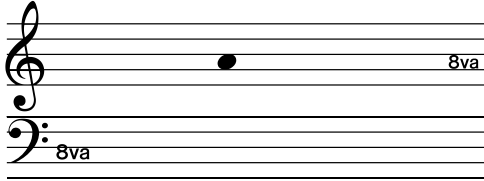

- If a note is too high or too low to be notated within the score, a note that is one octave lower or higher will be indicated on the score, along with "8va" at the top or bottom of the score.
- Due to the limitation of the screen, some notes in a chord may not be displayed.

Measure indicator

The measure numbers of a song or accompaniment are displayed. If you select a free-tempo song, "F t" appears.



Beat indicators

Four arrows flash to indicate the beat of a song or accompaniment.

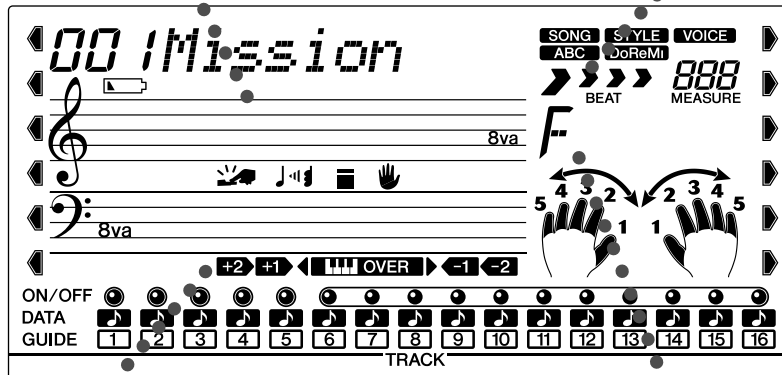

Octave indicator

While a Flash song is being played, this indicator appears if the key range of the notes being played is higher (or lower) than the EZ-30's keyboard range.



These indicators are displayed when the playback pitch is raised (or lowered) by an octave or two (page 73).



Chord indicator

This indicator indicates the name of the currently-played chord or a chord you play on the keyboard.



Fingering guide

During the Lesson, this guide suggests a fingering for playing the song.

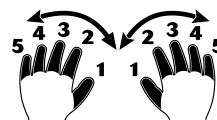

Selecting and Playing Songs

The EZ-30 has 100 preset songs. Try playing these songs or songs loaded into flash memory. Use the Song Memory function to record your own performance. (See page 66.)

Listening To a Demo Song

Press the [DEMO] button. Songs from #1 to #100 will be played sequentially.

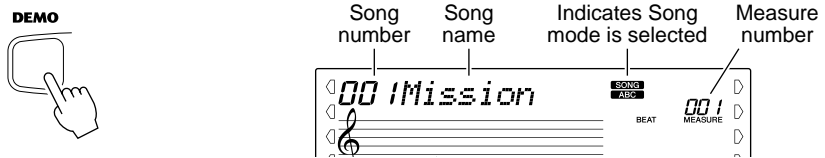

If you select a song after another song has started playing, the EZ-30 will sequentially play songs in the category (e.g., Pianist etc. See page 13.) that contains the selected song.



Note

- Turning the power on while pressing and holding down the [DEMO] button will disable the Demo song playback function. To enable the Demo song playback, turn the power on in the normal manner.
- If a song (or songs) has been loaded into flash memory, the Flash song(s) starts playing first.

Press the [START/STOP] button or the [DEMO] button to stop Demo playback.

Selecting and Playing a Song



Press the [SONG] button.

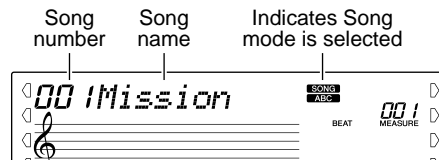
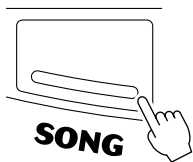

Select the desired song number.

Use the numeric keypad or the [+]/[-] buttons (page 25).

001–100	Preset Songs
101–(199)*	Flash Songs
201–205	User Songs

* The maximum song number differs depending on the amount of available flash memory.

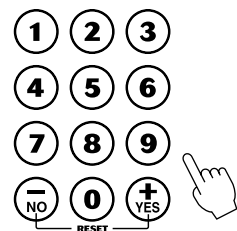

3

Start and stop the song playback.

Press the [START/STOP] button to start song playback.
 You can play the keyboard along with the playback.
 Press the [START/STOP] button to stop song playback.

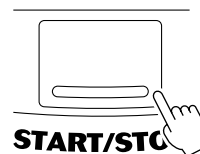

The playback will repeat until you press the [START/STOP] button.

Other controls

- [FF] button** Pressing this button during playback will fast forward the song.
 Pressing this button while playback is stopped will increment the measure number.
- [REW] button** Press this button during playback will rewind the song. (No sound will be heard at this time.)
 Pressing this button while playback is stopped will decrement the measure number.

Listening to a Flash Song

The EZ-30 can play a song loaded into its internal flash memory. To do this, you need to connect the EZ-30 to a personal computer, and use “Song Filer” application program on the computer to transmit a song.
 For more information on Flash songs and Song Filer, refer to page 71.

Switching the Tracks On and Off

Each song contains 16 tracks (1–16).

You can switch tracks 1–5 on and off using the **SONG MEMORY [1]–[5]** buttons respectively, and switch tracks 6–16 on and off altogether using the **[A]** button.

This is useful when you practice playing a certain track by switching that track off (the track sound will be muted).

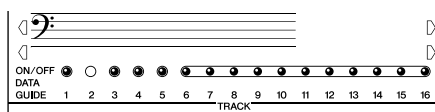
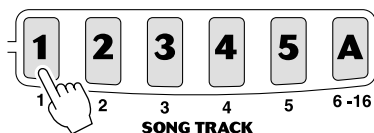

- ON/OFF indicator is lit. The corresponding track is played. (The track contains data.)
- ON/OFF indicator is off. The corresponding track is muted (no sound will be heard), or the track contains no data.

A song contains the following tracks:

- **Tracks [1]–[5]** Each track can be switched on and off individually.
- **Tracks [6]–[16]** Tracks 6–16 can be switched on and off altogether.

Melody Voice Change

You can change the voice of a song melody to the desired one during song playback.

1 Select the desired voice.

Press the [VOICE] button, then use the numeric keypad or [+]/[-] buttons to select the desired voice.



003PianoStr

2 Press and hold down the [VOICE] button for at least one second.

"MELODY VOICE CHANGE" appears in the display, indicating that the selected voice has replaced the song's original melody voice.



Adjusting the Tempo

Song and accompaniment tempo can be adjusted in the range of ♩ = 32–280 (the number of quarter notes per minute).



Press the [TEMPO/TAP] button.



Press the numeric keypad or [+]/[-] buttons to change the tempo value.

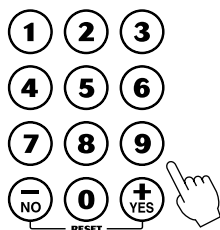

You can instantly restore the default setting by pressing both [+]/[-] buttons simultaneously (When Tempo is selected).

Tap Function

You can set your own tempo intuitively.

Press the [TEMPO/TAP] button four times for a four-beat song and three times for a three-beat song at a tempo at which you would like to play.



The Tap function is also available during song playback.

About beat indicators

During performance, the arrows flash sequentially in tempo.

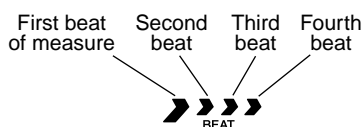

About free tempo

Some songs utilize a tempo that does not synchronize with or match the timing of the measures and beats as a way of enriching musical expression.

During the playback of such songs, the measure indicator indicates “Ft.”

Also, depending on the song, the beat indicators may not flash.

Song Volume Level

Adjust the song volume to balance with the level of the keyboard performance.



Press the right Overall button repeatedly until “SONG VOL” appears in the display.

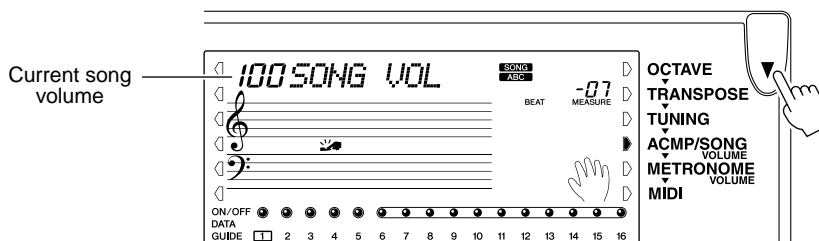

Press the numeric keypad or [+]/[-] buttons to set the song volume (000–127).

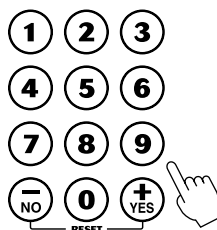

Note

- You can instantly restore the default setting of “100” by pressing both [+]/[-] buttons simultaneously (When Song Volume is selected).
- You can set the volume level of the selected song.

Switching the Light Guide On and Off

You can switch the Light Guide on the keyboard on or off.

The Light Guide can be used as a keyboard guide during song playback or while you are using the Lesson or the Dictionary function.



Press the left Overall button to select “LIGHT.”

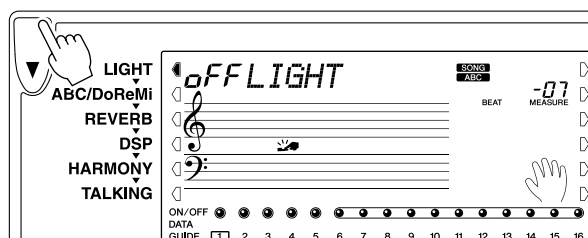



Press the [+] or [-] button to turn the Light Guide on or off.

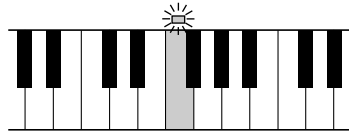
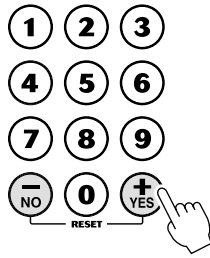

! CAUTION

Playing while looking at the lights for a long period of time may cause eye strain and stiff neck/shoulders. For your health and comfort, we recommend that you take a ten-minute break for every hour.

Song Lesson

You can practice playing a song selected from Lesson songs #001–100 and songs in flash memory.

Using the Lesson Feature



Select one of the Lesson songs.

Press the [SONG] button, then use the numeric keypad or [+]/[-] buttons to select the desired song.

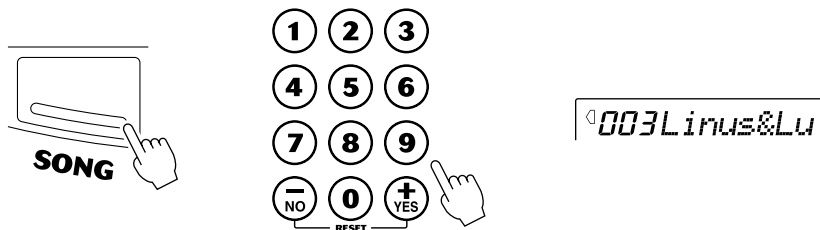

Select the part you wish to work on (left, right or both.)

If you want to work on the right-hand part, press the [R] button; to work on the left, press the [L] button. Press the [L] and [R] buttons simultaneously to work with both hands.



The icon of the selected hand(s) appears.

Track indicators

A lesson track(s) will be indicated by a frame around the GUIDE track number.

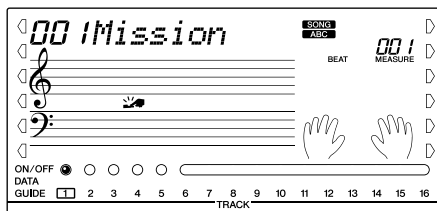

If a flash song is selected, you can change the track that guides your right- and left-hand part (See page 73).

3

Start the Lesson.

When you press one of the **LESSON** [1]–[3] buttons, the Lesson song starts. The display indicates the notes to play and the Light Guide shows you which key to play.

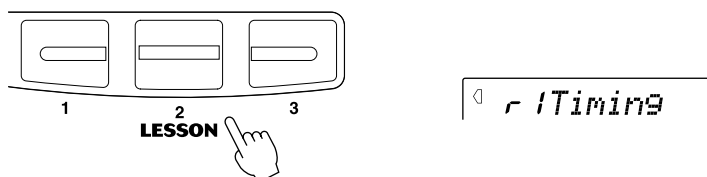

Types of Lesson

Press one of the following buttons to select and start a type of Lesson.

Lesson 1: Timing This lesson step lets you practice just the timing of the notes - any note can be used. The melody does not sound unless you play in rhythm.

Lesson 2: Waiting..... In this lesson step, the EZ-30 waits for you to play the correct notes before continuing playback of the song. When you play the correct note, the next note to play is indicated. Also, the EZ-30 can sing the next note to play using "A, B, C..." or "Do, Re, Mi..." (page 36).

Lesson 3: Minus One ... This lesson step lets you practice playing the correct notes along with the accompaniment. All parts except for the part you are practicing will be played in tempo like a "karaoke".



Note

- In Lesson 2, the rhythm part is muted.
- If the Talking function is turned on, the EZ-30 announces the Lesson number.
- To exit from the Lesson, press the corresponding **LESSON** button.

4

Press the [START/STOP] button to stop the Lesson.

The EZ-30 exits from the Lesson feature automatically when the [START/STOP] button is pressed.

ABC/DoReMi Guide

When the ABC/DoReMi Guide is activated, the EZ-30 sings the next note to play using "A, B, C..." or "Do, Re, Mi..." in Lesson 2.



For instruction on changing the guide voice (ABC or DoReMi), see page 43.



Press the left Overall button repeatedly to select "ABC/DoReMi."

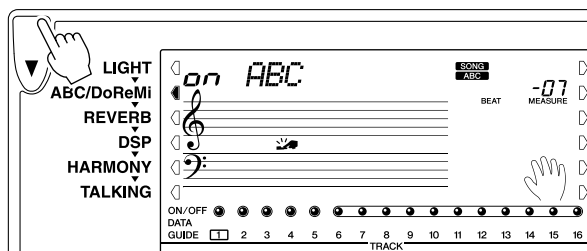

Press the [+] or [-] button to turn the ABC/DoReMi Guide on or off.

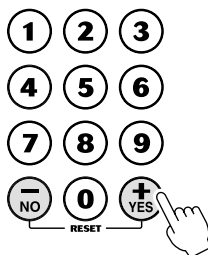

Grade

The Lesson feature has a built-in evaluation function that monitors your practicing of the Lesson songs, and just like a real teacher, it tells you how well you did each practice. Four grades are assigned, depending on your performance: "Try Again," "Good," "Very Good," and "Excellent." When the Talking function (page 38) is on, the EZ-30 also "announces" your grade.



Press the [GRADE ON/OFF] button to turn the Grade on or off.



The EZ-30 tells you your grade via the LCD, Light Guide, and the Talking function.

After displaying your grade, the EZ-30 resumes the Lesson.

Talking

This feature “talks” to you through the speakers, “announcing” the Grade comments as well as the titles of the Lesson steps and the names of certain functions.

- 1 Press the left Overall button repeatedly to select “TALKING”.

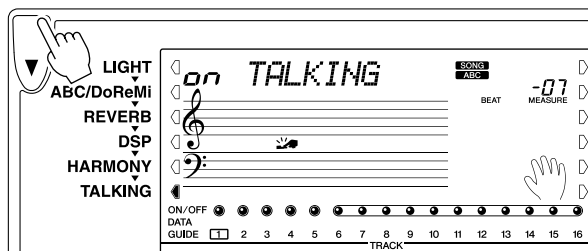

- 2 Press the [+]/[-] buttons to set Talking to on or off.

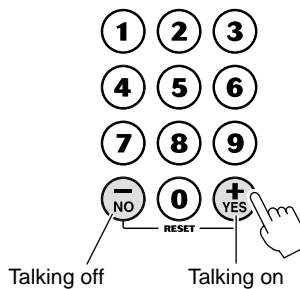

The Talking function includes the following “announcements”:

- [Dictionary]
- [LESSON 1–3]
- [Try Again]
- [Good]
- [Very Good]
- [Excellent]

Portable Grand

You can practice playing “a real piano,” by pressing the [PORTABLE GRAND] button.

When you press the [PORTABLE GRAND] button, the EZ-30 configures all the settings for piano performance.



PORTABLE GRAND

The EZ-30 configures the following settings when you press the [PORTABLE GRAND] button:

Voice	001 Grand Piano
Style	097 Stride
Song	081 Dolly's Dreaming And Awakening
Touch	On
One touch setting	On
Harmony	Off
Split point	054

The song and style category “PIANIST” (automatically selected with the settings described above) includes the songs and styles that are suitable for the piano performance.



The “PIANIST” styles are played without any rhythm sound.

Using the Metronome

Press the [METRONOME] button to play the Metronome in tempo with the accompaniment. You can use this feature for your piano practice.

A chime sounds at every first beat of the measures.



To turn the Metronome off, press the [METRONOME] button again.

Setting a Tempo

To change the tempo, press the [TEMPO/TAP] button and use the numeric keypad or [+]/[-] buttons to change the value. (See page 31.)



To restore the default Metronome Tempo value, press both [+]/[-] buttons simultaneously (when Metronome Tempo is selected in the Overall menu).

Setting the Time Signature of the Metronome

You can set the time signature of the Metronome while the rhythm part is stopped. Press and hold down the [METRONOME] button for more than one second to display the Metronome time signature setting, and use the numeric keypad or [+] / [-] buttons to change the time signature value.

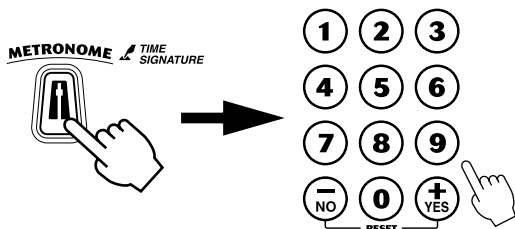

05 TIME SIG

Numeric keypad	Time signature
0	– (A chime does not sound.)
1	1/4 (A chime sounds on every beat.)
2	2/4
3	3/4
4	4/4
5	5/4
6	6/4
7	7/4
8	8/4
9	9/4
10	10/4
11	11/4
12	12/4
13	13/4
14	14/4
15	15/4



Note When you select another style or song, the time signature of the Metronome also changes to that of the selected style or song.

Adjusting the Metronome Volume

You can adjust the volume of the Metronome sound independently of the other EZ-30 sounds. The volume range is 000–127.

- 1 Press the right Overall button repeatedly to select “METRONOME VOLUME”.

Current Metronome Volume value

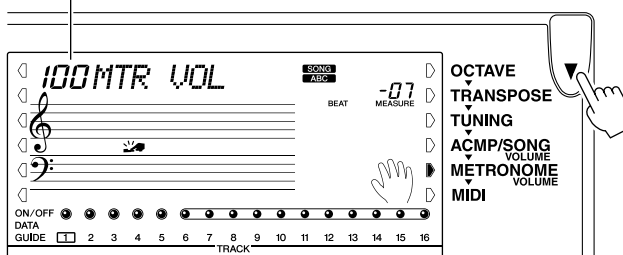

2 Press the numeric keypad or [+] / [-] buttons to set the desired Metronome Volume value.

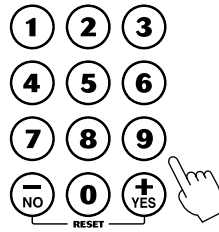

Note To restore the default Metronome Volume value (100), press both [+] / [-] buttons simultaneously (when Metronome Volume is selected in the Overall menu).

Playing Voices

Selecting a Voice

The EZ-30 features high-quality voices that use an advanced technology AWM (Advanced Wave Memory) tone generator. (See page 85.)

- **Voices** 1–116 (116 voices), 117–128 (drum kit), 609 (ABC (Oboe) voice), 610 (DoReMi (Oboe) voice)
- **Expanded Voices** 129–608 (480 voices)

Some voices include the following effects.

Split voice (107–116)

One voice is assigned to the right side of the split point on the keyboard, and another voice is assigned to the left side.

Drum kit (117–128)

Playing different keys on the keyboard produces different drum sounds.

ABC (Oboe) voice (609), DoReMi (Oboe) voice (610)

When you play the keyboard, the EZ-30 “sings” the corresponding notes using ABC or DoReMi. If the Transpose value is adjusted (other than “00”), they sound using Oboe voice.

Playing a Voice



Press the [VOICE] button.

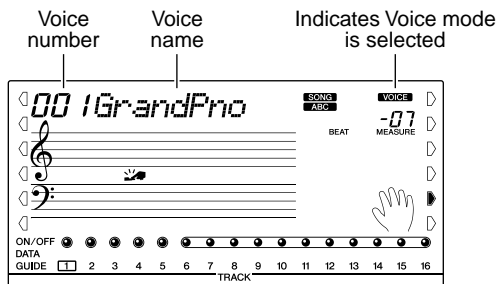

Select the desired voice number.

Use the numeric keypad to directly enter the voice number, or use the [+]/[-] buttons to step up and down through the voices (page 25).

3

Play the selected voice.

Try playing different voices.

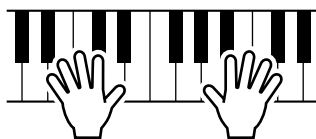

Note When you select a voice, a DSP type most appropriate for the voice will be selected automatically.

Selecting the ABC or DoReMi voice

Simply by pressing the [ABC/DoReMi] button, you can select the ABC (Oboe) voice (#609) or DoReMi (Oboe) voice (#610). The setting is also valid for the guide voice for the Lesson function (page 36).

1. Press the [ABC/DoReMi] button repeatedly to select the ABC or DoReMi voice.

Pressing the [ABC/DoReMi] button toggle among ABC voice, DoReMi voice and Guide Off.

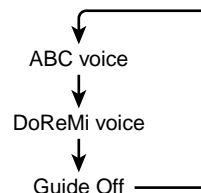
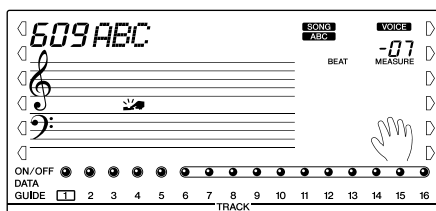

One Touch Setting

This special “voice” is actually a convenient feature which automatically selects a suitable voice for you when you select a style. The voice is selected to best match the style or song you’ve called up.

1

Press the [VOICE] button.

The name of the current voice appears.





Press the numeric keypad [0] or [+]/[-] buttons to select the voice number "000."

This turns on the One Touch Setting.

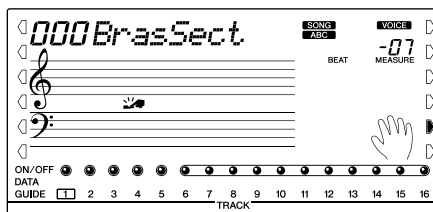
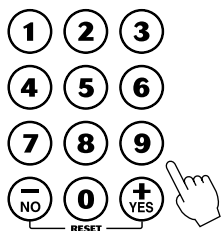

Changing the Split Point

Pressing and holding down the [ACMP ON/OFF] button for more than one second enables you to change the split point. If you have already selected a split voice, you can play a different voice on the right and left sides of the split point on the keyboard.

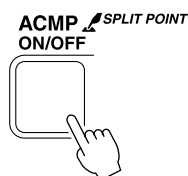

Current split point setting

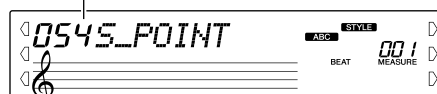

To restore the default setting of "54F#2," press both [+]/[-] buttons simultaneously.

Press the numeric keypad or [+]/[-] buttons to change the split point.

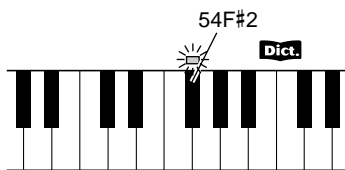
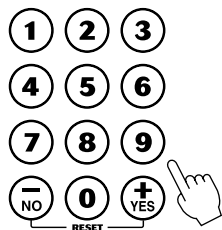

Current split point



"54F#2" means that the left side of the keyboard ranges up to F#2.

Split point for auto accompaniment

The split point for the auto accompaniment (the border between the melody key range and the accompaniment key range) is the same as that for the split voices.

Transpose

Transpose determines the key of both the main voice and the bass/chord accompaniment of the selected style. The Transpose settings can be adjusted over a range of ± 12 semitones (± 1 octave).



Press the right Overall button repeatedly to select "TRANPOSE".

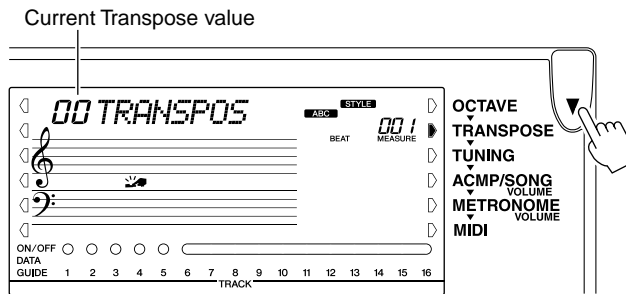

Press the numeric keypad or [+]/[-] buttons to set the desired Transpose value (-12 - +12).

To transpose the pitch down, simultaneously press and hold the [-] button, and use the numeric keypad to type in the (negative) value.

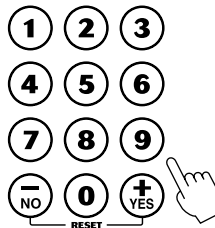

- You can instantly restore the default setting of "00" by pressing both [+]/[-] buttons simultaneously (when Transpose is selected).
- The Transpose function has no effect on the Drum Kits voices (#119–#128).
- If the Transpose value is adjusted (other than "00"), the ABC and DoReMi voices sound using Oboe voice.

Tuning

Tuning determines the fine pitch setting of both the main voice and the bass/chord accompaniment of the selected style. The Tuning settings can be adjusted over a range of ± 100 (approx. ± 1 semitone).

- 1 Press the right Overall button repeatedly to select "TUNING".

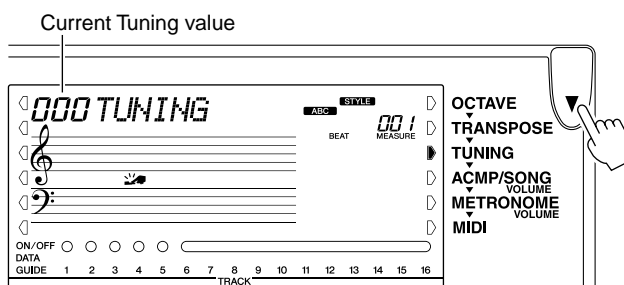

- 2 Press the numeric keypad or [+]/[-] buttons to set the desired Tuning value (-100 - +100).

To tune the pitch down, simultaneously press and hold the [-] button, and use the numeric keypad to type in the (negative) value.

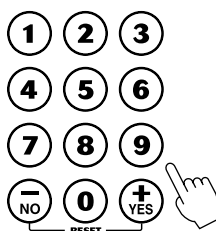

Note

- You can instantly restore the default setting of "000" by pressing both [+]/[-] buttons simultaneously (when Tuning is selected).
- The Tuning settings have no effect on the Drum Kit voices (#119–#128).

Touch

The Touch function gives you dynamic, expressive control over the voices, letting you determine how loud or soft the sound is by your playing strength.

Turn the Touch function on or off as desired by pressing the [TOUCH] button.

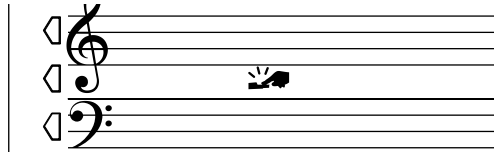
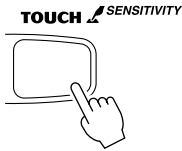

Indicates Touch function is turned on.

Touch Sensitivity

Touch Sensitivity lets you set how the EZ-30 responds to your playing strength, allowing you to customize this expressive function to suit your own playing style.

The higher the Touch Sensitivity setting, the more the sound volume changes in proportion to how strongly you play the keys.



Select the Touch Sensitivity control.

Press and hold the [TOUCH] button for more than one second to display the Touch Sensitivity setting.

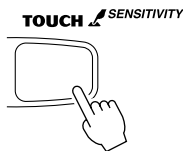

Current Touch Sensitivity setting

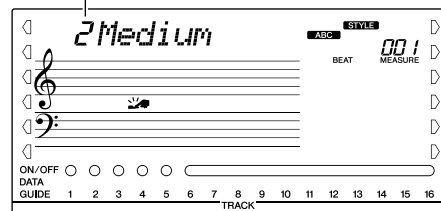

Change the value.

Use the numeric keypad or [+]/[-] buttons to set the desired setting: 1, 2, or 3.

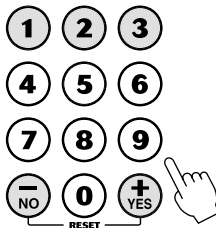

Settings:

1 (Soft)	This results in limited touch response, and produces a relatively narrow dynamic range, no matter how lightly or strongly you play the keys.
2 (Medium)	This lets you play over a normal dynamic range (soft to loud).
3 (Hard)	This is designed for playing very soft passages, giving you slightly more detailed control in the soft volume range.



The default Touch Sensitivity is 2.

Effects

Reverb

Press the left Overall button repeatedly to select “Reverb,” and use the numeric keypad or the [+]/[-] buttons to select a Reverb type.

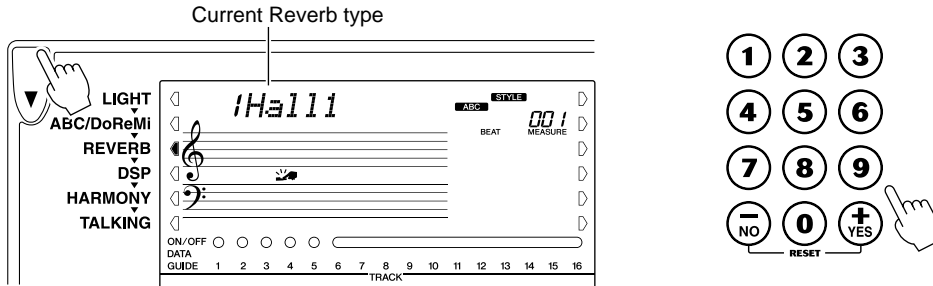

Selecting “9” turns the Reverb off.

[Reverb Type List]

No.	Reverb Type
1	Hall 1
2	Hall 2
3	Room 1
4	Room 2
5	Stage 1
6	Stage 2
7	Plate 1
8	Plate 2
9	Off



- Each style of the EZ-30 has its own independent Reverb setting.
- You can instantly restore the default setting by pressing both [+]/[-] buttons simultaneously (when Reverb is selected).

DSP

Press the left Overall button repeatedly to select “DSP,” and use the numeric keypad or the [+]/[-] buttons to select a DSP (Digital Signal Processor) type.

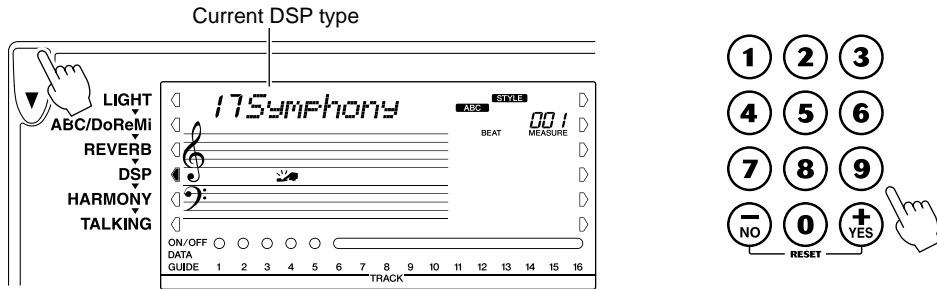

Selecting “39” turns the DSP off.

[DSP Type List]

No.	DSP Type
1	Hall 1
2	Hall 2
3	Room 1
4	Room 2
5	Stage 1
6	Stage 2
7	Plate 1
8	Plate 2
9	Early Reflection 1
10	Early Reflection 2
11	Gate Reverb
12	Reverse Gate
13	Chorus 1
14	Chorus 2
15	Flanger 1
16	Flanger 2
17	Symphonic
18	Phaser
19	Rotary Speaker 1
20	Rotary Speaker 2

No.	DSP Type
21	Tremolo 1
22	Tremolo 2
23	Guitar Tremolo
24	Auto Pan
25	Auto Wah
26	Delay Left - Center - Right
27	Delay Left - Right
28	Echo
29	Cross Delay
30	Karaoke
31	Distortion Hard
32	Distortion Soft
33	Overdrive
34	Amp Simulation
35	EQ Disco
36	EQ Telephone
37	3Band EQ
38	2Band EQ
39	No Effect



- Each voice of the EZ-30 has its own independent DSP setting.
- You can instantly restore the default setting by pressing both [+]/[-] buttons simultaneously (when DSP is selected).

Harmony

The Harmony section features a variety of performance effects that enhance the melodies you play when using the accompaniment styles of the EZ-30.

Some Harmony types add harmony to a chord detected in the left-hand key range (accompaniment key range).

Press the left Overall button repeatedly to select “Harmony,” and use the numeric keypad or the [+]/[-] buttons to select a Harmony type.

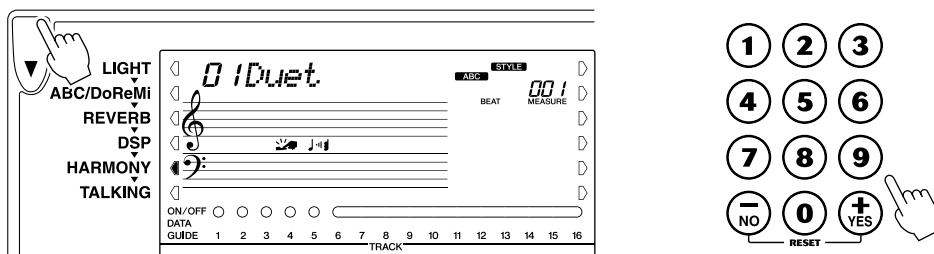

Selecting “27” turns the Harmony section off.

[Harmony Type List]

No.	Harmony Type
1	Duet
2	Trio
3	Block
4	Country
5	Octave
6	Trill 1/4 note
7	Trill 1/6 note
8	Trill 1/8 note
9	Trill 1/12 note
10	Trill 1/16 note
11	Trill 1/24 note
12	Trill 1/32 note
13	Tremolo 1/4 note
14	Tremolo 1/6 note

No.	Harmony Type
15	Tremolo 1/8 note
16	Tremolo 1/12 note
17	Tremolo 1/16 note
18	Tremolo 1/24 note
19	Tremolo 1/32 note
20	Echo 1/4 note
21	Echo 1/6 note
22	Echo 1/8 note
23	Echo 1/12 note
24	Echo 1/16 note
25	Echo 1/24 note
26	Echo 1/32 note
27	Off



- Harmony types 1–5 add harmony that matches the accompaniment chords.
- The speed of the Trill, Tremolo, and Echo effects depends on the Tempo setting.
- For more information on Harmony Types, see page 97.
- Harmony is added to only one note. If you play multiple keys, harmony notes are added based on the highest note or the last note you played.
- The Harmony function is disabled when you use the Dictionary function or the Lesson function.
- You can instantly restore the default setting by pressing both [+]/[-] buttons simultaneously (when Harmony is selected).

Auto Accompaniment

The EZ-30 provides dynamic rhythm/accompaniment patterns - as well as voice settings appropriate for each pattern - for various popular music styles. A total of 106 different styles are available, in several different categories.

With the auto accompaniment function, the EZ-30 automatically plays accompaniment parts (bass sound and chords) that match the selected style and the chords played in the accompaniment key range.

Select the desired accompaniment style and play the keyboard using the auto accompaniment function.

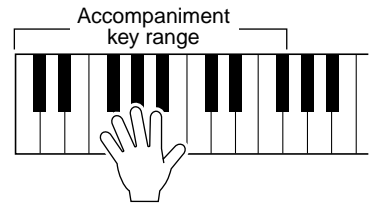

- Select an accompaniment style.** → Selecting a Style..... page 51
- ↓
- Start the accompaniment.** → Starting Accompaniment page 52
- ↓
- Play chords (left hand).** → Using Auto Accompaniment..... page 55
- ↓
- Play melody (right hand).** → Playing a Melody along with the Accompaniment..... page 61
- ↓
- Change the accompaniment section.** → Changing the Accompaniment Section..... page 62
- ↓
- Stop the accompaniment.** → Stopping the Accompaniment..... page 54

Selecting a Style

- 1 Press the [STYLE] button.

STYLE

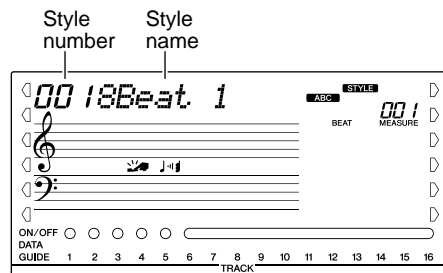

- 2 **Select the desired style number.**
Use the numeric keypad to directly enter the style number, or use the [+]/[-] buttons to step up and down through the styles (page 25).

Starting Accompaniment

Press the [ACMP ON/OFF] button to turn the auto accompaniment function on.

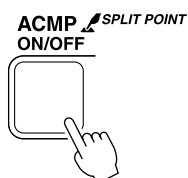

Accompaniment on indicator

You can start playing accompaniment using one of the following four methods.

Sync start

Press the [SYNC START] button. The EZ-30 enters Sync start waiting mode, and the beat indicators flash.

When you start playing chords in the accompaniment key range, the accompaniment starts playing.

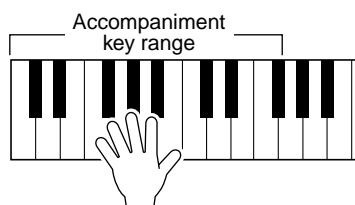
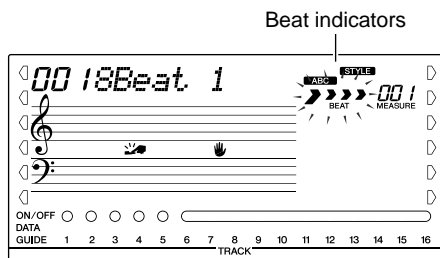
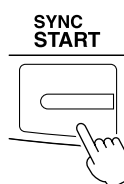

To cancel Sync start waiting mode, press the [SYNC START] button again. At this time, playing a chord in the accompaniment key range will produce bass sounds and chords without a rhythm section.

Sync stop

When you press the [SYNC STOP] button, the EZ-30 enters Sync start mode. When you release keys in the accompaniment key range, the accompaniment stops and the EZ-30 enters Sync start waiting mode.

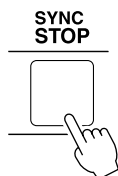

Sync stop indicator

Start

As soon as you press the [START/STOP] button, the rhythm part starts playing. When you play a chord in the accompaniment key range, the EZ-30 produces the bass and chords.

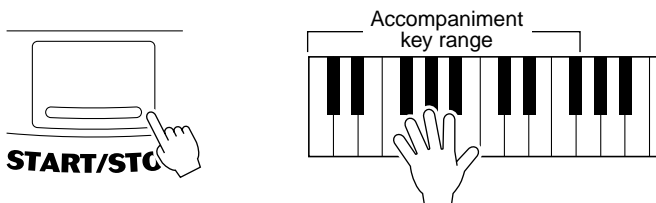

When you press the [START/STOP] button, only the rhythm part of the selected accompaniment starts playing. If any of accompaniment styles 97–106 (Accompaniment category: PIANIST) is selected, no rhythm part sounds.

Tap start

Press the [TEMPO/TAP] button four times for a four-beat song and three times for a three-beat song at a tempo at which you would like to play. The rhythm part starts playing.



Intro Sync start

Press the [SYNC START] button. The EZ-30 enters Sync start waiting mode, and the beat indicators flash. Then press the [INTRO/ENDING] button. The EZ-30 waits for the sync start that begins with an Intro section.

When you play a chord in the accompaniment key range, the accompaniment starts with an Intro section, followed by the Main A (or B) accompaniment section.

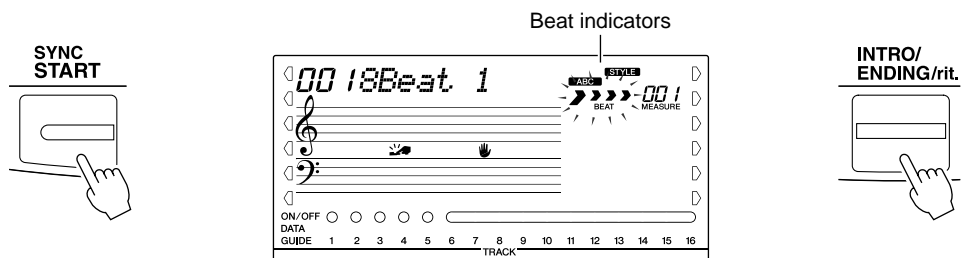

Stopping the Accompaniment

You can stop the accompaniment playback using one of the following three methods.

- Press the [START/STOP] button.

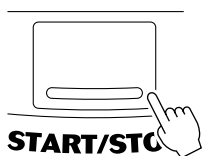

The accompaniment stops immediately.

- Press the [SYNC START] button.

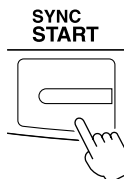

The accompaniment stops immediately. All beat indicators flash and the EZ-30 enters Sync start waiting mode.

- Press the [INTRO/ENDING] button.



The accompaniment stops after the ending section.

Changing the Tempo

The tempo of style playback can be adjusted over a range of 32–280 bpm (beats per minute).



- Press the [TEMPO/TAP] button.



Current Tempo value

120 TEMPO



- Press the numeric keypad or [+]/[-] buttons to set the desired value.

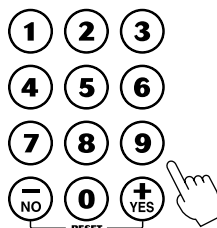

You can also use the convenient Tap Tempo function to change the tempo by “tapping” a new one in real time (page 31).



- When the rhythm part is stopped or Voice #000 is selected, selecting an accompaniment style automatically sets a tempo suitable for the accompaniment. If any voice other than Voice #000 is selected, changing the accompaniment during playback will not automatically change the tempo.
- You can instantly restore the default setting by pressing both [+]/[-] buttons simultaneously (when Tempo is selected).





Using Auto Accompaniment—Multi Fingering

When it is set to on (page 52), the auto accompaniment function automatically generates bass and chord accompaniment for you to play along with, by using Multi Fingering operation. You can change the chords of the accompaniment by playing keys in the auto accompaniment key range using either the “Single Finger” or “Fingered” method. With Single Finger you can simply play a one-, two- or three-finger chord indication (see “Single Finger Chords” below). The Fingered technique is that of conventionally playing all the notes of the chord.

Whichever method you use, the EZ-30 “understands” what chord you indicate and then automatically generates the accompaniment.

Single Finger Chords

Chords that can be produced in Single Finger operation are major, minor, seventh and minor seventh. The illustration shows how to produce the four chord types. (The key of C is used here as an example; other keys follow the same rules. For example, B \flat 7 is played as B \flat and A.)

	C To play a major chord: Press the root note of the chord.
	Cm To play a minor chord: Press the root note together with the nearest black key to the left of it.
	C7 To play a seventh chord: Press the root note together with the nearest white key to the left of it.
	Cm7 To play a minor seventh chord: Press the root note together with the nearest white and black keys to the left of it (three keys altogether).



A root key and keys you play

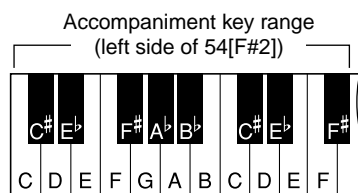

Fingered Chords

Using the key of C as an example, the chart below shows the types of chords that can be recognized in the Fingered mode.

• Example for "C" chords

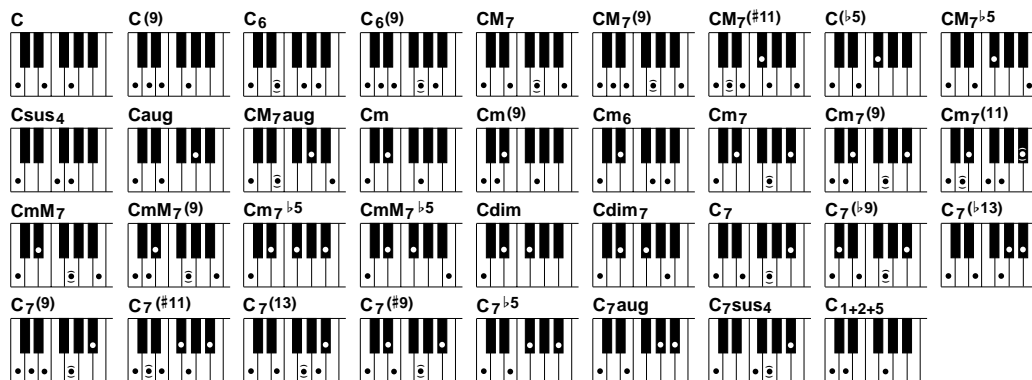

* Notes enclosed in parentheses are optional; the chords will be recognized without them.

Chord Name/[Abbreviation]	Normal Voicing	Chord (C)	Display
Major [M]	1 - 3 - 5	C	C
Add ninth [(9)]	1 - 2 - 3 - 5	C(9)	C(9)
Sixth [6]	1 - (3) - 5 - 6	C6	C6
Sixth ninth [6(9)]	1 - 2 - 3 - (5) - 6	C6(9)	C6(9)
Major seventh [M7]	1 - 3 - (5) - 7 or 1 - (3) - 5 - 7	CM7	CM7
Major seventh ninth [M7(9)]	1 - 2 - 3 - (5) - 7	CM7(9)	CM7(9)
Major seventh add sharp eleventh [M7(#11)]	1 - (2) - 3 - #4 - 5 - 7 or 1 - 2 - 3 - #4 - (5) - 7	CM7(#11)	CM7(#11)
Flatted fifth [(b5)]	1 - 3 - b5	C(b5)	Cb5
Major seventh flatted fifth [M7b5]	1 - 3 - b5 - 7	CM7b5	CM7b5
Suspended fourth [sus4]	1 - 4 - 5	Csus4	Csus4
Augmented [aug]	1 - 3 - #5	Caug	Caug
Major seventh augmented [M7aug]	1 - (3) - #5 - 7	CM7aug	CM7aug
Minor [m]	1 - b3 - 5	Cm	Cm
Minor add ninth [m(9)]	1 - 2 - b3 - 5	Cm(9)	Cm(9)
Minor sixth [m6]	1 - b3 - 5 - 6	Cm6	Cm6
Minor seventh [m7]	1 - b3 - (5) - b7	Cm7	Cm7
Minor seventh ninth [m7(9)]	1 - 2 - b3 - (5) - b7	Cm7(9)	Cm7(9)
Minor seventh add eleventh [m7(11)]	1 - (2) - b3 - 4 - 5 - (b7)	Cm7(11)	Cm7(11)

Chord Name/[Abbreviation]	Normal Voicing	Chord (C)	Display
Minor major seventh [mM7]	1 - ♭3 - (5) - 7	CmM7	CmM7
Minor major seventh ninth [mM7(9)]	1 - 2 - ♭3 - (5) - 7	CmM7(9)	CmM7(9)
Minor seventh flattened fifth [m7♭5]	1 - ♭3 - ♭5 - ♭7	Cm7♭5	Cm7♭5
Minor major seventh flattened fifth [mM7♭5]	1 - ♭3 - ♭5 - 7	CmM7♭5	CmM7♭5
Diminished [dim]	1 - ♭3 - ♭5	Cdim	Cdim
Diminished seventh [dim7]	1 - ♭3 - ♭5 - 6	Cdim7	Cdim7
Seventh [7]	1 - 3 - (5) - ♭7 or 1 - (3) - 5 - ♭7	C7	C7
Seventh flattened ninth [7(♭9)]	1 - ♭2 - 3 - (5) - ♭7	C7(♭9)	C7(♭9)
Seventh add flattened thirteenth [7(♭13)]	1 - 3 - 5 - ♭6 - ♭7	C7(♭13)	C7(♭13)
Seventh ninth [7(9)]	1 - 2 - 3 - (5) - ♭7	C7(9)	C7(9)
Seventh add sharp eleventh [7(#11)]	1 - (2) - 3 - #4 - 5 - ♭7 or 1 - 2 - 3 - #4 - (5) - ♭7	C7(#11)	C7(#11)
Seventh add thirteenth [7(13)]	1 - 3 - (5) - 6 - ♭7	C7(13)	C7(13)
Seventh sharp ninth [7(#9)]	1 - #2 - 3 - (5) - ♭7	C7(#9)	C7(#9)
Seventh flattened fifth [7♭5]	1 - 3 - ♭5 - ♭7	C7♭5	C7♭5
Seventh augmented [7aug]	1 - 3 - #5 - ♭7	C7aug	C7aug
Seventh suspended fourth [7sus4]	1 - 4 - (5) - ♭7	C7sus4	C7sus4
One plus two plus five [1+2+5]	1 - 2 - 5	C1+2+5	C



- Notes in parentheses can be omitted.
- A perfect fifth (1 + 5) produces accompaniment based only on the root and fifth which can be used with both major and minor chords.
- Playing two same root keys in the adjacent octaves produces accompaniment based only on the root.
- The chord fingerings listed are all in “root” position, but other inversions can be used - with the following exceptions:
m7, m7♭5, 6, m6, sus4, aug, dim7, 7♭5, 6(9), 1+2+5.
- Inversion of the 7sus4 and m7(11) chords are not recognized if the notes shown in parentheses are omitted.
- The auto accompaniment will sometimes not change when related chords are played in sequence (e.g. some minor chords followed by the minor seventh).
- Two-note fingerings will produce a chord based on the previously played chord.
- The split point for the auto accompaniment function is the same as that for the split voices. (See page 44.)

Looking up Chords in the dictionary

The Dictionary function is essentially a built-in “chord book” that shows you the individual notes of chords. It is ideal when you know the name of a certain chord and want to quickly learn how to play it.

1 Press the [Dict.] button.

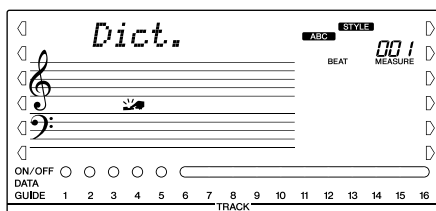
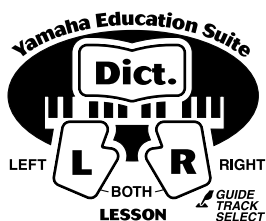

2 Specify the root of the chord.

Press the key on the keyboard that corresponds to the desired chord root (as printed on the panel).
Pressing this key selects the root G.

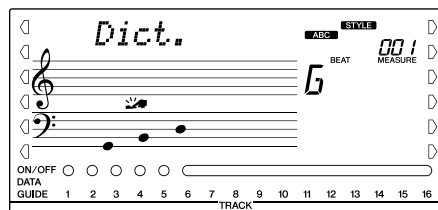
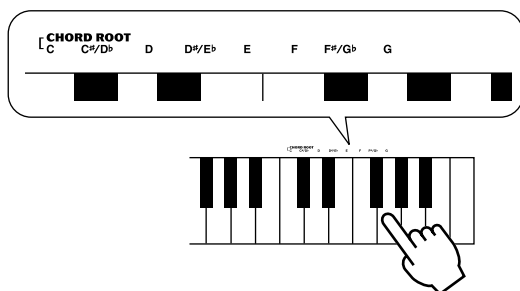

3 Specify the type of the chord (major, minor, seventh, etc.).

Press the key on the keyboard that corresponds to the desired chord type (as printed on the panel).
In this example, play M7 keys.

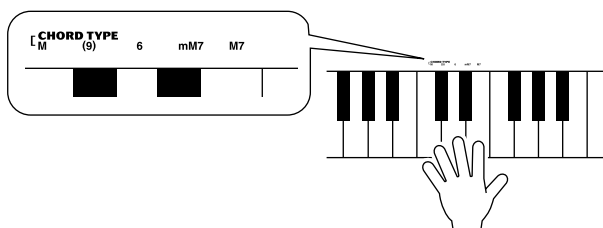

- Usually, a Major chord name is represented by a root note name. E.g., “C” represents C Major.
- If you press [+]/[-] buttons, another inversion will be indicated.



Play a chord, following the Light Guide.

The display indicates the notes of the GM7 chord, and the Light Guide indicates which keys to play on the keyboard.

The chord name flashes in the display (and a “congratulations” melody is played) when the correct notes are held down.

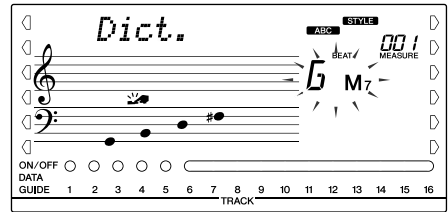

..... What is a Chord?

The simple answer: Three or more notes played simultaneously is a chord. (Two notes played together is an “interval” — an interval being the distance between two different notes. This is also referred to as a “harmony.”) Depending on the intervals between the three or more notes, a chord can sound beautiful or muddy and dissonant.

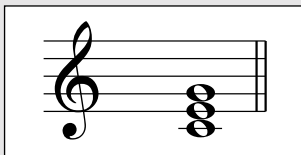

The organization of notes in the example at left — a triad chord — produces a pleasant, harmonious sound. Triads are made up of three notes and are the most basic and common chords in most music.

In this triad, the lowest note is the “root.” The root is the most important note in the chord, because it anchors the sound harmonically by determining its “key” and forms the basis for how we hear the other notes of the chord.

The second note of this chord is four semitones higher than the first, and the third is three semitones higher than the second. Keeping our root note fixed and changing these notes by a semitone up or down (sharp or flat), we can create four different chords.

Major chord (ex. C)	Minor chord (ex. Cm)	Augmented chord (ex. Caug)	Diminished chord (ex. Cdim)

Keep in mind that we can also change the “voicing” of a chord — for example, change the order of the notes (called “inversions”), or play the same notes in different octaves — without changing the basic nature of the chord itself.

Inversion examples for the key of C



Beautiful sounding harmonies can be built in this manner. The use of intervals and chords is one of the most important elements in music. A wide variety of emotions and feelings can be created depending on the types of chords used and the order in which they are arranged.

Playing a Melody along with the Accompaniment

You can play a melody along with the accompaniment.

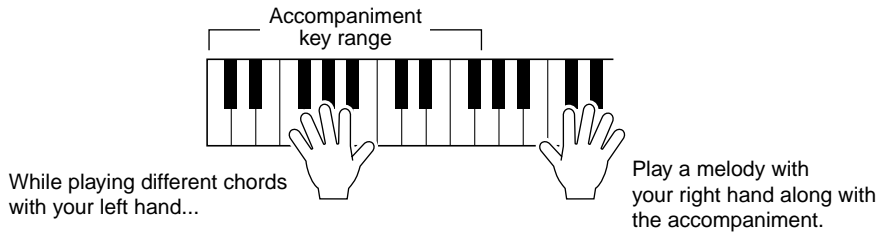

Set a tempo you feel comfortable with. (See page 54.)

Adjusting the Accompaniment Volume

The playback volume of the accompaniment can be adjusted. This volume control affects only the accompaniment volume.



Press the right Overall button repeatedly until “ACMP VOL” appears in the display.

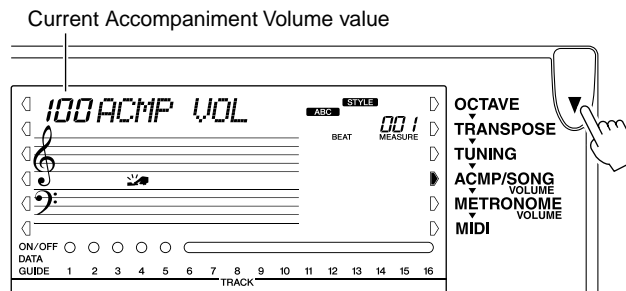

Press the numeric keypad or [+] / [-] buttons to set the desired Accompaniment Volume value (000–127).

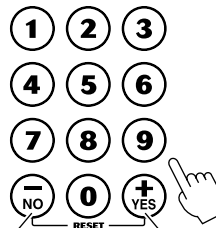

The value decreases and the volume level is lowered.

The value increases and the volume level is raised.



- You can instantly restore the default setting of “100” by pressing both [+] / [-] buttons simultaneously (when Accompaniment Volume is selected).
- Accompaniment Volume cannot be changed unless the Style mode is active.

Changing the Accompaniment Section

Accompaniment consists of Intro, Main A/B (Fill-in), and Ending sections. Using different sections based on the structure of songs enables you to enhance musical expression.

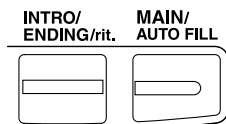

Intro

Press the [INTRO/ENDING] button before you start playing to select an Intro section. The Intro section is followed by the Main section.



Press the button before the rhythm part starts.

Press the [MAIN/AUTO FILL] button before pressing the [START/STOP] button to specify the Main section that follows the Intro section.

To cancel the Intro section, press the [INTRO/ENDING] button again. The display indicates the Main section (A or B) that will be played when the song starts.

Main

There are two Main sections, A and B. When you press the [MAIN/AUTO FILL] button, the EZ-30 plays the Fill-in pattern, then changes to another variation.



Note You can also assign the accompaniment sections by pressing the [MAIN/AUTO FILL] button before the song starts (while the rhythm part is stopped).

About the Fill-in Patterns

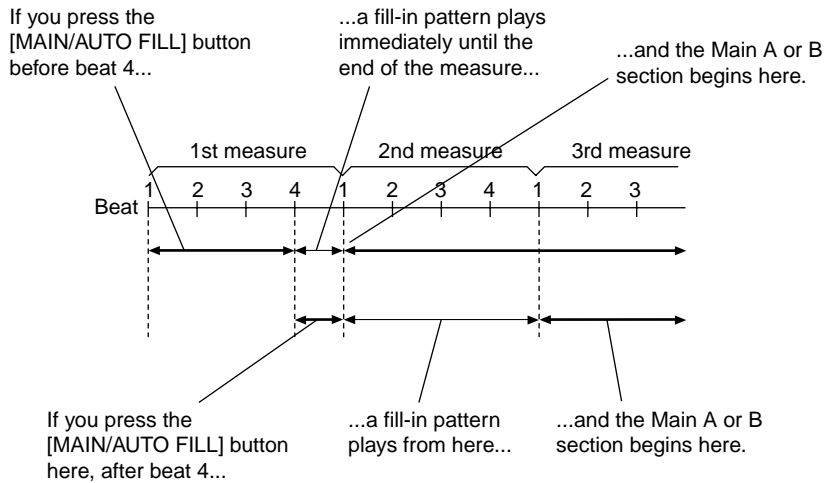

Ending

When you press the [INTRO/ENDING] button at the end of the song, the EZ-30 plays the Ending section appropriate for the song, then stops the performance.



Ritardando (rit.)

If you press the [INTRO/ENDING] button during the Ending section, the song gets slower little by little and then stops.

Registration Memory

Registration Memory is a flexible and convenient function that lets you instantly reconfigure virtually all settings of the EZ-30 with the touch of a single button. Simply save your favorite custom panel settings to one of the Registration Memory presets (up to sixteen are available) for future recall.

Recording a Registration Memory Preset

Each of the sixteen Registration Memory can have different settings for the following parameters:

- Voice number
- Split Point
- Split On/Off
- Reverb Type
- DSP Type
- Harmony On/Off setting and Type
- Style number *
- Accompaniment On/Off *
- MAIN A/B *
- Accompaniment Split Point *
- Accompaniment volume *
- Tempo *
- Transpose

* These settings are disabled with the songs.

The EZ-30 has eight Registration Memory banks, each with two different presets (a total of sixteen).

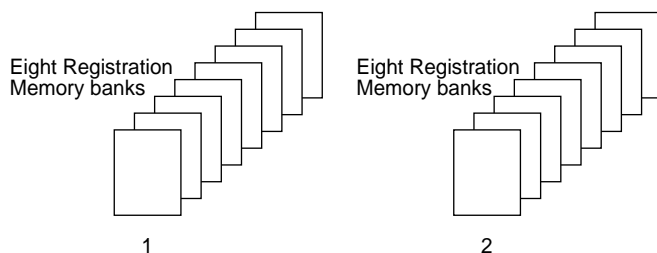

Make all desired settings for the EZ-30.

Virtually all of the EZ-30's settings can be saved to a Registration Memory button.



Select the desired bank.

Press the [BANK] button, then press the desired bank number (1–8).

REGISTRATION MEMORY
MEMORY 1 2 BANK x8

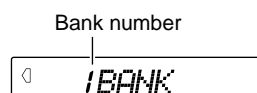
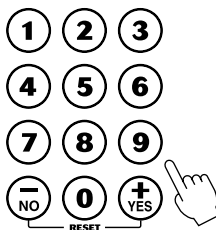
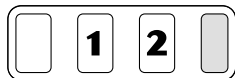

3

Record the settings to the desired preset, 1 or 2.

While holding down the [MEMORY] button, press the appropriate REGISTRATION MEMORY preset button, [1] or [2].

REGISTRATION MEMORY
MEMORY 1 2 BANK x8



Bank number



 If you select a REGISTRATION MEMORY preset button to which data has already been recorded, the existing data will be overwritten and deleted.

Recalling a Registration Memory Preset

1

Select the appropriate Registration Memory bank.

 If you recall settings from a Registration Memory preset, the current panel settings will be lost. Save important panel settings to another Registration Memory preset.

REGISTRATION MEMORY
MEMORY 1 2 BANK x8

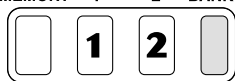

1 2 3

4 5 6

7 8 9

NO 0 YES

RESET



2

Press the desired Registration Memory preset button ([1] or [2]).

REGISTRATION MEMORY
MEMORY 1 2 BANK x8



Song Recording

The EZ-30's Song Memory function enables you to record up to five songs of your performance as User songs (Song #201–205: User 1–5).

You can also play the recorded songs in the same way as the preset songs.

Recording a User Song

The EZ-30 lets you play and record the individual parts of your own song in real time. You can record your performance to six tracks per User song (1–5).

- **Melody tracks [1]–[5]**Record melody to these tracks.
- **Accompaniment track [A]**.....Record chords to this track.

Data that can be recorded to the normal (melody) tracks:

- Note on/off
- Velocity
- Voice Number
- Reverb Type *
- DSP Type *
- Sustain
- Tempo *, Time Signature * (if no data is recorded in the accompaniment track)

Data that can be recorded to the accompaniment track:

- Chord changes and timing
- Changing sections (Intro, Main A/B, etc.)
- Style number *
- Accompaniment Volume *
- Reverb Type *
- DSP Type *
- Tempo, Time Signature *

* These settings can only be recorded once at the beginning of a song; other settings can be changed in the middle of a song.



- Note that song data will be lost if you turn off the power to the EZ-30, unplug the power adaptor from the AC outlet, or if the battery fully discharges while you are recording.
- Song Memory Capacity:
Maximum number of notes: approximately 10,000 (when only “melody” tracks are recorded)
Maximum number of chords: approximately 5,500 (when only the accompaniment track is recorded)



Select a User song for recording.

Use the numeric keypad or [+]/[-] buttons to select the desired song: 201–205.

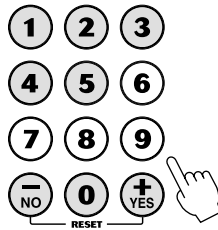

REC User 2



Note If no song is manually selected, the EZ-30 automatically selects the first available empty song number.



Select a track number for recording.

Check the display for the track DATA indicators and select an unrecorded track.

● Recording a melody track and an accompaniment track at the same time:

While pressing and holding down the [RECORD] button, press the desired SONG MEMORY button [1]–[5] and [A] button.

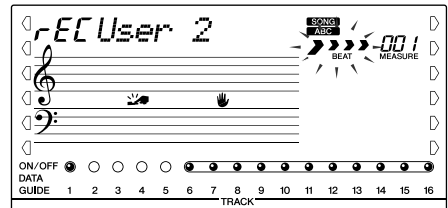
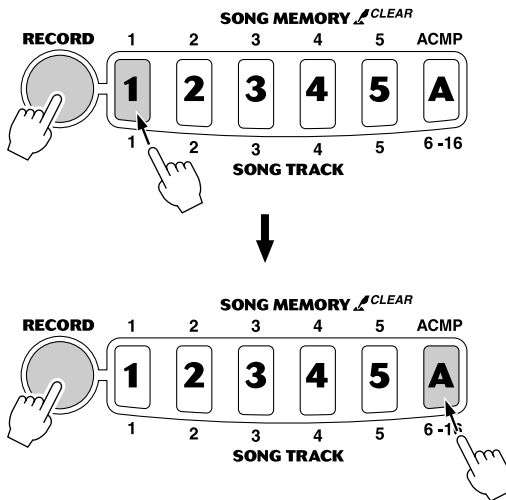

Keep in mind that all recording operations “replace” the data.

In other words, if you record to a track that already has recorded data, all previous data in the track will be erased and replaced by the newly recorded data.



- If you select the accompaniment track for recording, the auto accompaniment function is automatically enabled.
- You cannot turn the auto accompaniment function on or off after recording has started.
- If you are recording using a split voice, the voice below the split point will not be recorded.

● Recording a melody track:

While pressing and holding down the [RECORD] button, select the desired melody track button (1–5). The selected track's number flashes on the display.

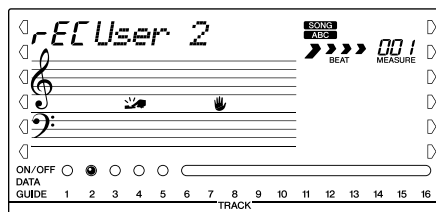
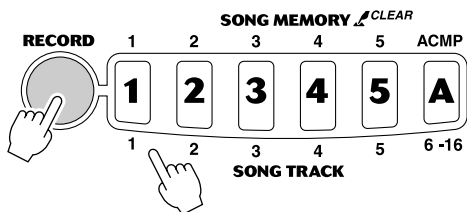

Note

- If auto accompaniment is turned on and the accompaniment track is not recorded, a melody track and the accompaniment track will automatically be selected as recording tracks. If you wish to record only the accompaniment track, press the button for the flashing melody track indicator to deselect the melody track. The melody track indicator is turned off.
- To cancel recording, press the button for the flashing track indicator. The track indicator is turned off.

3

Start recording.

You can start recording simply by playing the keyboard (or by pressing the [START/STOP] button).

The current measure number is indicated on the display during recording.

4

Stop recording.

After you've finished playing the part, press the [START/STOP] or [RECORD] button.

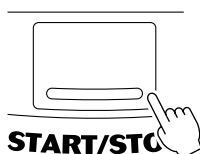

or



When you press the [INTRO/ENDING] button while recording the accompaniment track, the EZ-30 plays the Ending section and stops recording.

When recording is finished, the measure number on the display is reset to "001" and the recorded tracks DATA indicators light up.

5

Record to other tracks as desired.

To do this, simply repeat steps #2–#4 above. Make sure that when you press the [SONG MEMORY] button corresponding to the desired track, the track number in the display flashes.

● Re-recording...

Select the recorded tracks as recording tracks.

When you start recording, the new performance will overwrite the existing data. (The existing data will be deleted and replaced with new data.)

Erasing a Song

Song Clear

The Song Clear operation completely erases all recorded data on all tracks of a selected User song.



To erase an individual track of a song while leaving the other tracks intact, use the Track Clear operation (page 70).

1 Select the desired song.

Press the [SONG] button, then use the numeric keypad or [+]/[-] buttons to select the desired song (201–205).

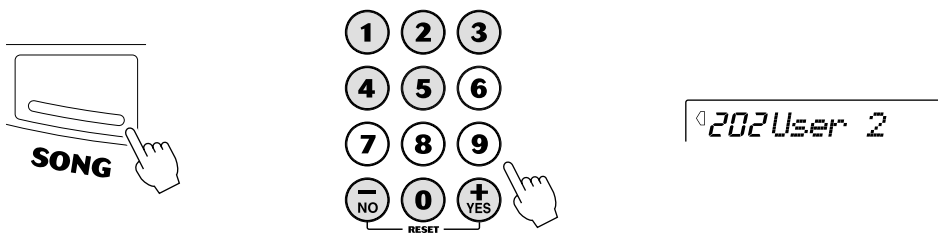

2 While holding down the [A] button, press SONG MEMORY button [1].

All track indications in the display flash, indicating that all tracks are to be erased.

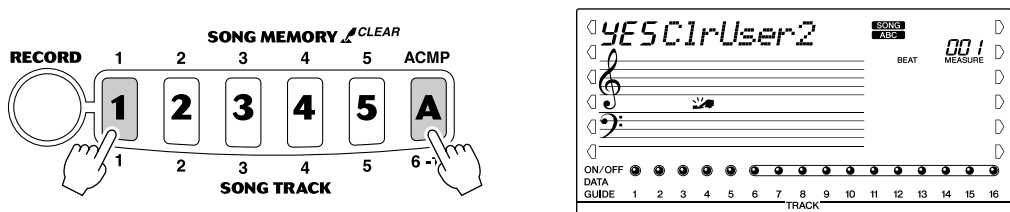

3 Press the [+]/YES button.

YES Sure?

4 At the “Sure?” prompt, press the [+]/YES button, or press the [-]/NO button to abort.

Pressing the [+]/YES button executes the Song Clear operation. Pressing the [-]/NO button aborts.

Track Clear

The Track Clear operation completely erases all recorded data on a selected track of a selected User song, leaving the other tracks intact.

1 Select the desired song.

Press the [SONG] button, then use the numeric keypad or [+]/[-] buttons to select the desired song (201–205).

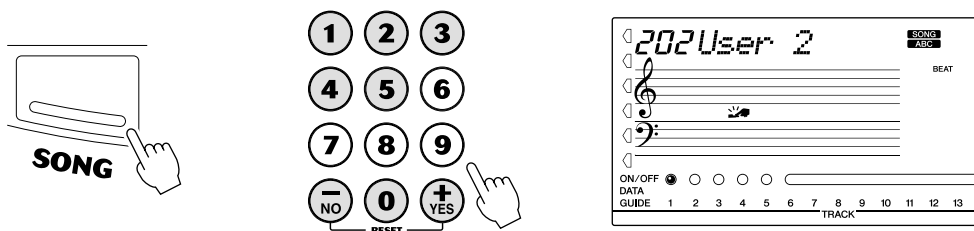

2 Press and hold down the button corresponding to the track to be erased.

Press and hold down the appropriate SONG MEMORY button ([1]–[5], [A]) for at least one second.

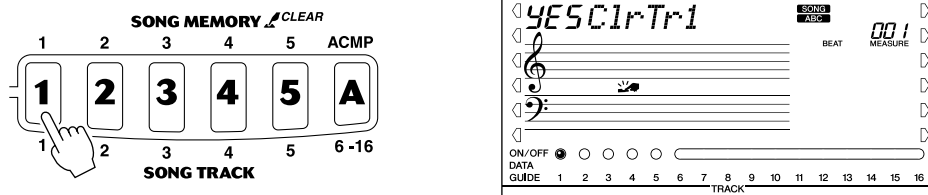

3 Press the [+]/YES] button.

4 At the “Sure?” prompt, press the [+]/YES] button, or press the [-]/NO] button to abort.

Pressing the [+]/YES] button executes the Track Clear operation. Pressing the [-]/NO] button aborts.

Loading a Song into Flash Memory

The EZ-30's internal flash memory enables you to save song data transmitted from a connected personal computer. You can play or practice Flash songs (saved in flash memory) in the same way as preset songs.

To transmit song data from a personal computer to the EZ-30, you first need to install "Song Filer" application on the computer.

Song data that can be saved in flash memory:

The number of songs: max. 99 songs (Song #101–)

Available memory: 488 KB

Data format: SMF

Installing Song Filer

You can download "Song Filer" application from the following Yamaha PK CLUB website. Make sure that your computer has an Internet connection.

Yamaha PK CLUB (Portable Keyboard Home Page)

<http://www.yamahaPKclub.com/>

System requirements for Song Filer:

[Windows]

OS: Windows 95/98/Me/2000

CPU: Pentium/100MHz or faster

Available Memory: 8MB or more

Free space in Hard Disk: 2MB or more

Display: 800 x 600, 256 colors or more

[Macintosh]

OS: Mac OS 7.5 or upper

CPU: Power PC or upper

Available Memory: 8MB or more

Free space in Hard Disk: 2MB or more

Display: 800 x 600, 256 colors or more



Visit the Yamaha PK CLUB website for more information on the latest version of Song Filer and the installation method.

Song Filer's Functions

After you install Song Filer on the computer and connect the EZ-30 to the computer, you can use the two functions described below.



Note

- Refer to page 78 for information on connecting the EZ-30 to a computer.
- You cannot use the Song Filer's "Receive Files" function with the EZ-30.
- For more information on using Song Filer, refer to the PDF manual included in the Song Filer application.

● Transmit Files

You can transmit song files from your computer to your EZ-30's Flash Memory.

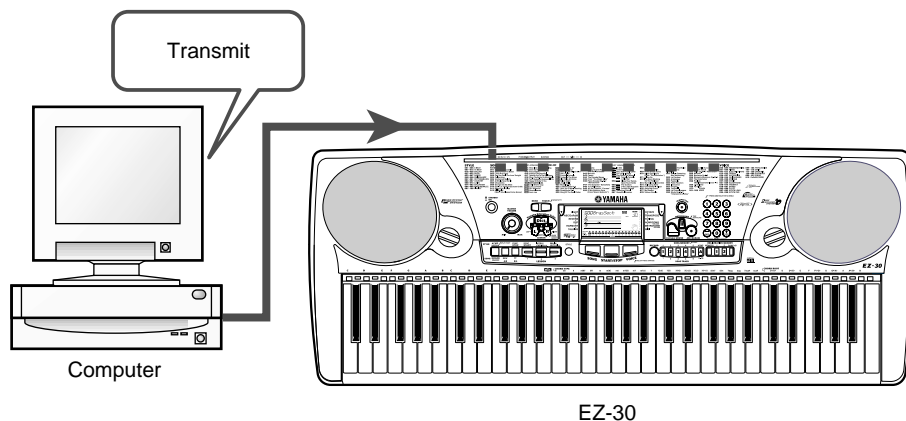

● Manage Files on Flash Memory

You can delete and rename files on your EZ-30's Flash Memory using your computer.

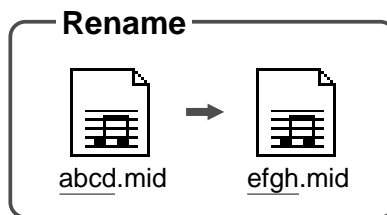
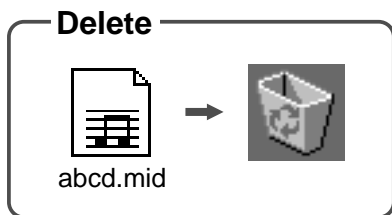

Octave

If the notes in a Flash song are outside the EZ-30's key range (C1–C6), You can change their pitch in octave steps so that you can use the Lesson function. If the **OVER** indicator appears in the lower-left of the display during playback of flash songs, follow the procedure:

- 1 Stop the song, and press the right Overall button to select "OCTAVE".

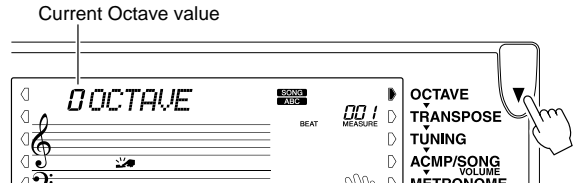

- 2 Press the [+]/[-] buttons to set the desired Octave value (-2 – +2) until the **OVER** indicator disappears.

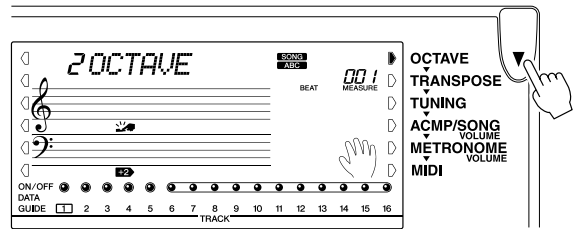
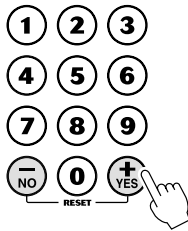

- You can instantly restore the default setting of "0" by pressing both [+]/[-] buttons simultaneously (when Octave is selected).
- You can set the Octave function only for the Flash songs.

Selecting a right/left-hand guide track

You can select a track that guides your right and left hand fingering during the Lesson (See page 34). This function is available only when you select a flash memory song (SMF format 0).

1. While the song is stopped, press and hold down the **LESSON [R]** or **[L]** button to select the desired part.

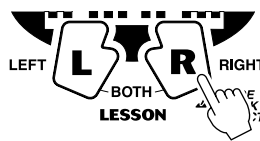

A frame appears around the number of the GUIDE track.

2. Press the numeric keypad or [+]/[-] buttons to select a lesson track number.

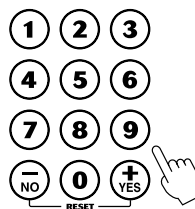

Available Flash Memory Amount



Press the right Overall button repeatedly to select "MIDI".

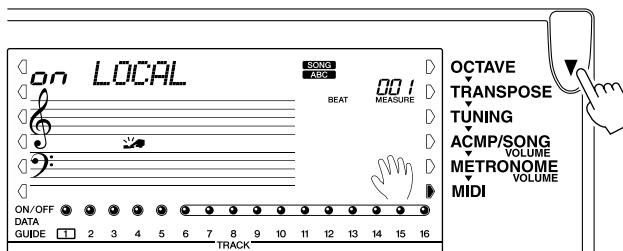

Press the [4] button to display "F-SIZE."

The amount of available memory is indicated in KB.

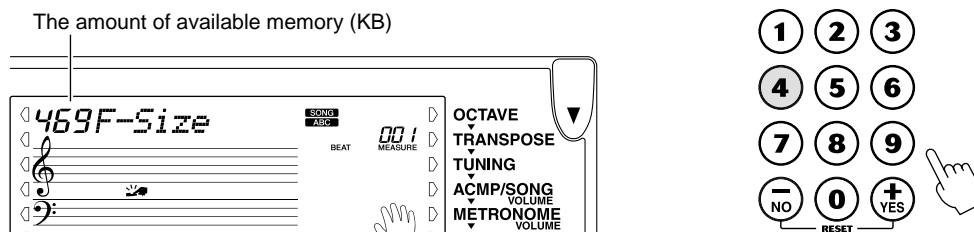

Flash Clear

All data in flash memory (Song #101-) can be initialized.



Press the [STANDBY/ON] switch to turn off the power to the EZ-30.

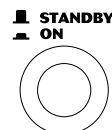

While holding down the highest black key (A#5), press the [STANDBY/ON] switch to turn on the power to the EZ-30.

The flash memory will be initialized. When the initialization is complete, the EZ-30 indicates "ClrFlash" on the display.

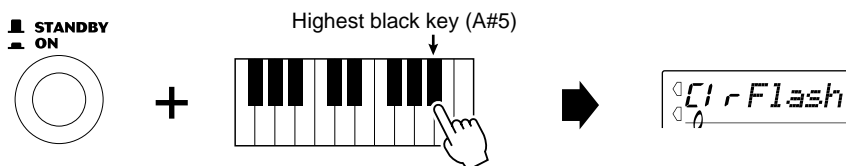

See page 84 for information on initializing the panel settings.

MIDI Functions

The EZ-30 is MIDI-compatible, featuring MIDI IN and MIDI OUT terminals and providing a variety of MIDI-related controls. By using the MIDI functions you can expand your musical possibilities. This section explains what MIDI is, and what it can do, as well as how you can use MIDI on your EZ-30.

What is MIDI?

No doubt you have heard the terms “acoustic instrument” and “digital instrument.” In the world today, these are the two main categories of instruments. Let’s consider an acoustic piano and a classical guitar as representative acoustic instruments. They are easy to understand. With the piano, you strike a key, and a hammer inside hits some strings and plays a note. With the guitar, you directly pluck a string and the note sounds. But how does a digital instrument go about playing a note?

• Acoustic guitar note production

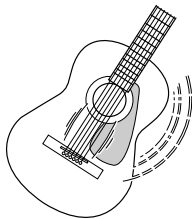

Pluck a string and the body resonates the sound.

• Digital instrument note production

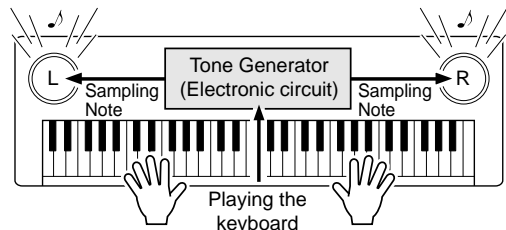

Based on playing information from the keyboard, a sampling note stored in the tone generator is played through the speakers.

Based on playing information from the keyboard, a sampling note stored in the tone generator is played through the speakers.

As shown in the illustration above, in an electronic instrument the sampling note (previously recorded note) stored in the tone generator section (electronic circuit) is played based on information received from the keyboard. So then what is the information from the keyboard that becomes the basis for note production?

For example, let’s say you play a “C” quarter note using the grand piano sound on the EZ-30 keyboard. Unlike an acoustic instrument that puts out a resonated note, the electronic instrument puts out information from the keyboard such as “with what voice,” “with which key,” “about how strong,” “when was it pressed,” and “when was it released.” Then each piece of information is changed into a number value and sent to the tone generator. Using these numbers as a basis, the tone generator plays the stored sampling note.

Example of Keyboard Information

Voice number (with what voice)	01 (grand piano)
Note number (with which key)	60 (C3)
Note on (when was it pressed) and note off (when was it released)	Timing expressed numerically (quarter note)
Velocity (about how strong)	20 (strong)

MIDI Functions

MIDI is an acronym that stands for Musical Instrument Digital Interface, which allows electronic musical instruments to communicate with each other, by sending and receiving compatible Note, Control Change, Program Change and various other types of MIDI data, or messages.

The EZ-30 can control a MIDI device by transmitting note related data and various types of controller data. The EZ-30 can be controlled by the incoming MIDI messages which automatically determine tone generator mode, select MIDI channels, voices and effects, change parameter values and of course play the voices specified for the various parts.

MIDI messages can be divided into two groups: Channel messages and System messages. Below is an explanation of the various types of MIDI messages which the EZ-30 can receive/transmit.

Channel Messages

The EZ-30 is an electronic instrument that can handle 16 channels. This is usually expressed as “it can play 16 instruments at the same time.” Channel messages transmit information such as Note ON/OFF, Program Change, for each of the 16 channels.

Message Name	EZ-30 Operation/Panel Setting
Note ON/OFF	Messages which are generated when the keyboard is played. Each message includes a specific note number which corresponds to the key which is pressed, plus a velocity value based on how hard the key is struck.
Program Change	Voice number (along with corresponding bank select MSB/LSB settings, if necessary).
Control Change	Messages that are used to change some aspect of the sound (modulation, volume, pan, etc.).

System Messages

This is data that is used in common by the entire MIDI system. System messages include messages like Exclusive Messages that transmit data unique to each instrument manufacturer and Realtime Messages that control the MIDI device.

Message Name	EZ-30 Operation/Panel Setting
Exclusive Message	Reverb/chorus/DSP settings, etc.
Realtime Messages	Clock setting Start/stop operation

The messages transmitted/received by the EZ-30 are shown in the MIDI Implementation Chart on page 98.

GM System Level 1

“GM System Level 1” is an addition to the MIDI standard which ensures that any GM-compatible music data can be accurately played by any GM-compatible tone generator, regardless of manufacturer.

The GM mark is affixed to all software and hardware products that support GM System Level 1. The EZ-30 supports GM System Level 1.



MIDI Terminals

In order to exchange MIDI data between multiple devices, each device must be connected by a cable.

The MIDI terminals of the EZ-30 are located on the rear panel.

- **MIDI IN** Receives MIDI data from another MIDI device.
- **MIDI OUT** Transmits the EZ-30's keyboard information as MIDI data to another MIDI device.

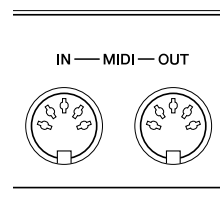

MIDI LSB receive cancel

To set the EZ-30 so that it will not receive LSB data for Bank Select, press the [STANDBY/ON] switch to turn on the power to the EZ-30 while holding down the lowest key (C1).

To cancel this setting, turn on the power to the EZ-30 again in the normal manner.

Available MIDI Functions

The EZ-30 has MIDI IN/OUT terminals on the rear panel.

Using the MIDI functions can expand your possibilities for creating and playing music.

- Playing on a MIDI keyboard (without an internal tone generator) can produce sound on the EZ-30.



- You can record performance data created on the EZ-30 (performance using the keyboard and auto accompaniment: 1-16 channels) to an external sequencer (such as sequence software on a computer). You can then edit the performance data on the external sequencer and play it again on the EZ-30.

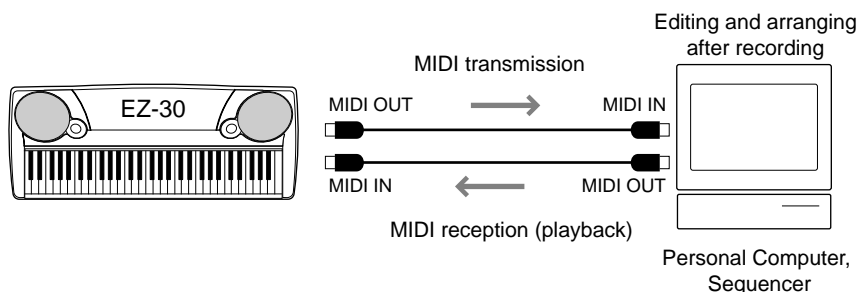

→ Initial send (See page 81.)

You can send song data from a computer to the EZ-30's internal flash memory. (See page 71.)

Performance data recorded in User songs can be output via MIDI and saved in an external device as SMF data for other applications. (See page 82.)



Note

- You will need sequence software to use a personal computer.
- You can use the notation display and Light Guide for note data that is received on Channel 1.
- The songs (1–20) and Flash songs are not output via MIDI.
- To transmit song data to flash memory, first you need to install Song Filer on the computer. (See page 71.)

Connecting to a Personal Computer

By connecting your EZ-30's MIDI terminals to a personal computer, you can have access to a wide variety of music software.

When using a MIDI interface device installed in the personal computer, connect the MIDI terminals of the personal computer and the EZ-30.

Use only special MIDI cables when connecting MIDI devices.

- Connect the MIDI terminals of the EZ-30 to the MIDI terminals of the personal computer.

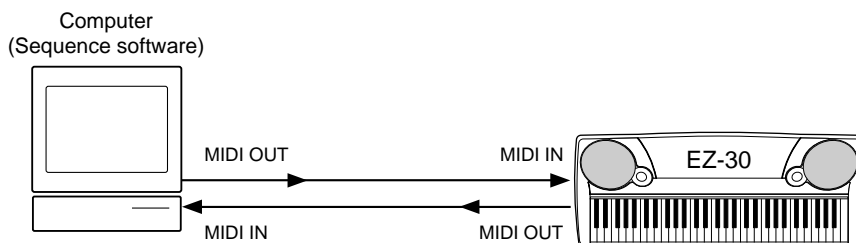

- When using a MIDI interface with a Macintosh series computer, connect the RS-422 terminal of the computer (modem or printer terminal) to the MIDI interface, as shown in the diagram below.

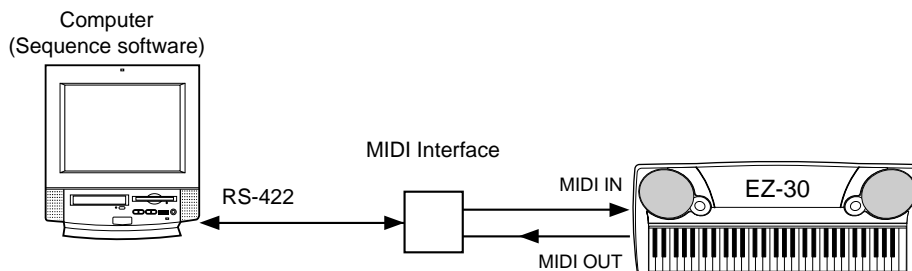

- To connect a computer with a USB terminal to the EZ-30, you need an optional USB-MIDI interface.

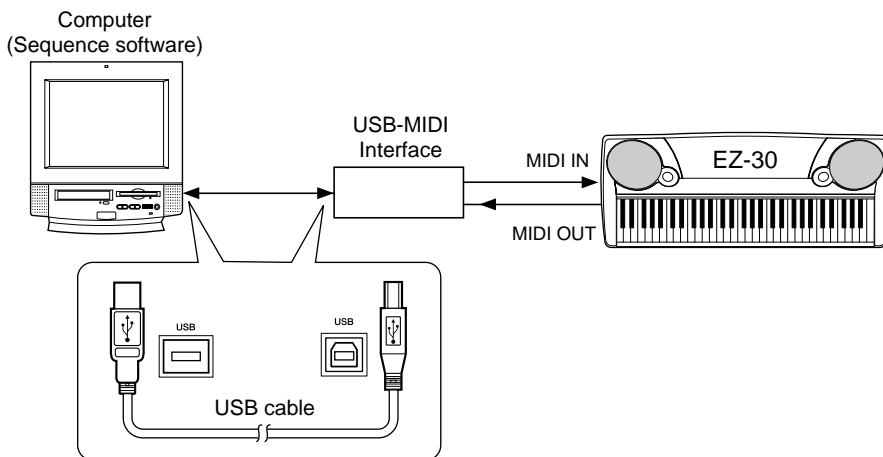

Note When using a Macintosh series computer, set the MIDI interface clock setting in the application software to match the setting of the MIDI interface you are using. For details, refer to the owner's manual for the software you are using.

Local Control

This function lets you enable or disable keyboard control over the EZ-30's voices. This would come in handy, for example, when recording notes to MIDI sequencer. If you are using the sequencer to play back the voices of the EZ-30, you would want to set this to "off" - in order to avoid getting "double" notes, both from the keyboard and from the sequencer. Normally, when playing the EZ-30 by itself, this should be set to "on."



Press the right Overall button repeatedly to select "MIDI".

If "LOCAL" does not appear in the display, press the [1] button.

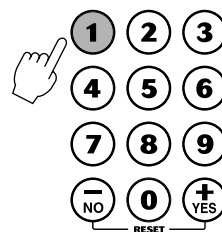
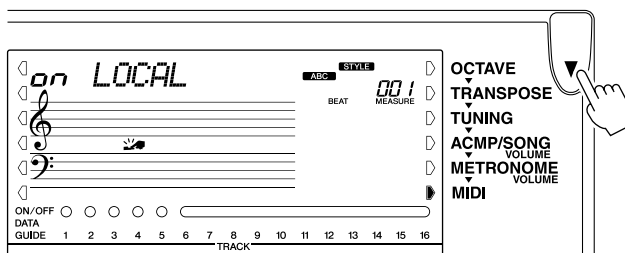

Press the [+]/[-] buttons to set Local Control to on or off.

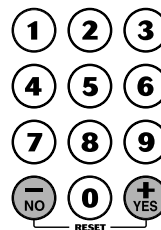

Loading Bulk Data •••••

Once you've saved EZ-30 data as described above, you can easily reload the data back to the EZ-30. Send the data from the connected MIDI device. The EZ-30 automatically receives the data. When the operation is completed, the display returns to the currently selected voice.

 **This operation erases any and all of your original data in the EZ-30. Make sure to save your original settings and data using the Bulk Dump operation described above.**



- Make sure that the EZ-30 is not in the middle of an operation, such as song recording or playback, Accompaniment playback, saving a Registration Memory preset, sending Bulk Dump data, etc.
- When the EZ-30 is receiving bulk data, none of the panel controls can be used.
- If, for some reason, some problem occurred in the data reception, a "RcvError" message is shown in the display. Check all connections and settings and try the operation again.

Transmitting the EZ-30 Panel Settings (Initial Send)

The EZ-30's panel settings can be transmitted to an external device.

Recording data to an external sequencer enables you to play back the data utilizing the panel settings used for the recording.



Press the right Overall button repeatedly to select "MIDI."

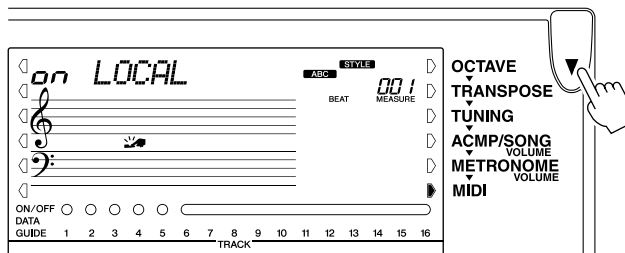

Press the [3] button to display "INITSEND".

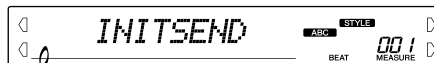

Press the [START/STOP] button to execute Initial Send.

When the transmission is complete, "End" appears in the display.

Transmitting SMF Format Data

Performance data recorded in the EZ-30's User songs can be transmitted via MIDI and stored in the SMF format.

- 1** Select a User song to transmit.
- 2** Follow the steps described above in the "Transmitting the EZ-30 Panel Settings (Initial Send)" section.
- 3** Press the [SONG] button, then the [START/STOP] button to transmit the song data. You can store the data (received on the computer via MIDI) in the SMF format file so that it can be used for another application.

Troubleshooting

Problem	Possible Cause and Solution
When the EZ-30 is turned on or off, a popping sound is temporarily produced.	This is normal and indicates that the EZ-30 is receiving electrical power.
<ul style="list-style-type: none"> • The volume level is low. • Tonal quality has degraded. • Recorded songs are not played correctly. • The display indication is turned off suddenly and the panel settings are reset. 	The battery voltage is low. Replace all six batteries with new ones, or use the AC adaptor.
Noise is produced from the EZ-30.	When using a mobile phone, noise is produced. Using a mobile phone in close proximity to the EZ-30 may produce interference. To prevent this, turn off the mobile phone or use it further away from the EZ-30.
There is no sound even when the keyboard is played or when a song is being played back.	Check that nothing is connected to the PHONES/OUTPUT jack on the rear panel. When a set of headphones is plugged into this jack, no sound is output.
	When using the Dictionary function (page 58), the keys in the right hand section are used only for entering the chord root and type.
The effects (Reverb/DSP/Harmony) are not applied.	Each effect (Reverb/DSP/Harmony) is turned off. Select a type for each effect. (See page 48, 49, 50.)
The auto accompaniment doesn't turn on, even when pressing the [ACMP ON/OFF] button.	When playing back one of the Pianist styles (#97–#106), the rhythm cannot be heard. The Pianist styles have no drums or bass - only piano accompaniment.
Not all of the voices seem to sound, or the sound seems to be cut off.	The EZ-30 is polyphonic up to a maximum of 32 notes. If the Dual voice or Split voice is being used and a style or song is playing back at the same time, some notes/sounds may be omitted (or "stolen") from the accompaniment or song.
Auto accompaniment is not played correctly.	The accompaniment volume setting is low. Refer to page 61 to raise the volume level.
	The auto accompaniment split point is set incorrectly for the played chords. See page 44 to set a correct split point.
The polarity of the footswitch is reversed.	You turned on the power to the EZ-30 while pressing the footswitch. Turn the power off, then turn it on again without pressing the footswitch.

Data Backup & Initialization

Data Backup

Except for the data listed below, all EZ-30 panel settings are reset to their initial settings whenever the power is turned on. The data listed below are backed up - i.e. retained in memory - as long as an AC adaptor is connected or a set of batteries is installed.

- User Song Data
- Song Volume
- Registration Memory Data
- Registration Memory Bank Number
- Metronome Volume
- Touch On/Off
- Tuning
- Grade On/Off
- Talking On/Off
- Guide Voice On/Off

Data Initialization

All data can be initialized and restored to the factory preset condition by turning on the power while holding the highest (rightmost) white key on the keyboard. "CLr Backup" will appear briefly on the display.

- 1 Press the [STANDBY/ON] switch to turn off the power to the EZ-30.

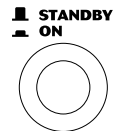

- 2 While holding down the highest white key, press the [STANDBY/ON] switch to turn on the power to the EZ-30 to initialize the data. When initialization is complete, the display indicates "CLr Backup."

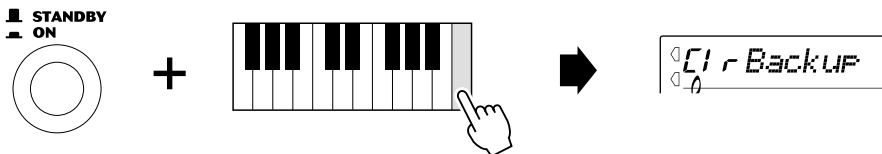

 **All Registration Memory and User song data, plus the other settings listed above, will be erased and/or changed when the data initialization procedure is carried out.**



Note

- Carrying out the data initialization procedure will usually restore normal operation if the EZ-30 freezes or begins to act erratically for any reason.
- Refer to page 74 for information on initializing flash memory.

Voice List

■ Maximum Polyphony

The EZ-30 has 32-note maximum polyphony. This means that it can play a maximum of up to 32 notes at once, regardless of what functions are used. Auto Accompaniment uses a number of the available notes, so when Auto Accompaniment is used the total number of available notes for playing on the keyboard is correspondingly reduced. The same applies to the Split Voice and Song functions.



- The Voice List includes MIDI program change numbers for each voice. Use these program change numbers when playing the EZ-30 via MIDI from an external device.
- Some voices may sound continuously or have a long decay after the notes have been released while the sustain pedal (footswitch) is held.

Voice#	Bank Select#		MIDI Program Change#	Voice Name
	MSB#	LSB#		
PIANO				
001	000	112	000	Grand Piano
002	000	112	001	Bright Piano
003	000	112	000	Piano and Slow Strings
004	000	112	002	MIDI Grand Piano
005	000	112	003	Honky-tonk Piano
006	000	112	006	Harpichord
E.PIANO				
007	000	112	005	DX Modern Elec. Piano
008	000	112	004	Funky Electric Piano
009	000	113	005	Hyper Tines
010	000	114	005	Venus Electric Piano
011	000	112	007	Clavi
ORGAN				
012	000	112	016	Jazz Organ 1
013	000	113	016	Jazz Organ 2
014	000	112	017	Click Organ
015	000	116	016	Bright Organ
016	000	112	018	Rock Organ
017	000	114	018	Purple Organ
018	000	118	016	16'+2' Organ
019	000	119	016	16'+4' Organ
020	000	114	016	Theater Organ
021	000	112	019	Church Organ
022	000	113	019	Chapel Organ
023	000	112	020	Reed Organ
ACCORDION				
024	000	113	021	Traditional Accordion
025	000	112	021	Musette Accordion
026	000	113	023	Bandoneon
027	000	112	022	Harmonica
GUITAR				
028	000	112	024	Classical Guitar
029	000	112	025	Folk Guitar
030	000	113	025	12Strings Guitar
031	000	112	026	Jazz Guitar
032	000	113	026	Octave Guitar
033	000	112	027	Clean Guitar
034	000	112	028	Muted Guitar
035	000	112	029	Overdriven Guitar
036	000	112	030	Distortion Guitar
BASS				
037	000	112	032	Acoustic Bass
038	000	112	033	Finger Bass
039	000	112	034	Pick Bass
040	000	112	035	Fretless Bass
041	000	112	036	Slap Bass
042	000	112	038	Synth Bass

Voice#	Bank Select#		MIDI Program Change#	Voice Name
	MSB#	LSB#		
043	000	113	038	Hi-Q Bass
044	000	113	039	Dance Bass
STRINGS				
045	000	112	048	String Ensemble
046	000	112	049	Chamber Strings
047	000	112	050	Synth Strings
048	000	113	049	Slow Strings
049	000	112	044	Tremolo Strings
050	000	112	045	Pizzicato Strings
051	000	112	055	Orchestra Hit
052	000	112	040	Violin
053	000	112	042	Cello
054	000	112	043	Contrabass
055	000	112	105	Banjo
056	000	112	046	Harp
CHOIR				
057	000	112	052	Choir
058	000	113	052	Vocal Ensemble
059	000	112	053	Vox Humana
060	000	112	054	Air Choir
SAXOPHONE				
061	000	112	064	Soprano Sax
062	000	112	065	Alto Sax
063	000	112	066	Tenor Sax
064	000	114	066	Breathy Tenor
065	000	112	067	Baritone Sax
066	000	112	068	Oboe
067	000	112	069	English Horn
068	000	112	070	Bassoon
069	000	112	071	Clarinet
TRUMPET				
070	000	112	056	Trumpet
071	000	112	059	Muted Trumpet
072	000	112	057	Trombone
073	000	113	057	Trombone Section
074	000	112	060	French Horn
075	000	112	058	Tuba
BRASS				
076	000	113	061	Big Brass
077	000	113	061	Brass Sax
078	000	112	061	Brass Section
079	000	119	061	Mellow Horns
080	000	112	062	Synth Brass
081	000	113	062	Jump Brass
FLUTE				
082	000	112	073	Flute
083	000	112	072	Piccolo
084	000	112	075	Pan Flute

Voice#	Bank Select#		MIDI Program Change#	Voice Name
	MSB#	LSB#		
085	000	112	074	Recorder
086	000	112	079	Ocarina
SYNTH LEAD				
087	000	112	080	Square Lead
088	000	112	081	Sawtooth Lead
089	000	115	081	Analogon
090	000	119	081	Fargo
091	000	114	062	Techno Brass
092	000	113	002	SynPiano
093	000	112	098	Star Dust
SYNTH PAD				
094	000	112	088	Fantasia
095	000	113	100	Bell Pad
096	000	112	091	Xenon Pad
097	000	112	094	Equinox
098	000	113	089	Dark Moon
PERCUSSION				
099	000	112	011	Vibraphone
100	000	112	012	Marimba
101	000	112	013	Xylophone
102	000	112	114	Steel Drums
103	000	112	008	Celesta
104	000	112	014	Tubular Bells
105	000	112	047	Timpani
106	000	112	010	Music Box
SPLIT				
107	--	--	--	Acoustic Bass/Piano
108	--	--	--	FingerBass/Bright Piano
109	--	--	--	Fretless Bass/ DX Modern EP
110	--	--	--	FretlessBass/Vibraphon
111	--	--	--	FretlessBass/Brass
112	--	--	--	Analogon/SawLead
113	--	--	--	SlapBass/Clavinet
114	--	--	--	Guitar/Flute
115	--	--	--	Strings/Piano
116	--	--	--	VoxHumana/Choir
DRUM KITS				
117	127	000	000	Standard Kit 1
118	127	000	001	Standard Kit 2
119	127	000	008	Room Kit
120	127	000	016	Rock Kit
121	127	000	024	Electronic Kit
122	127	000	025	Analog Kit
123	127	000	027	Dance Kit
124	127	000	032	Jazz Kit
125	127	000	040	Brush Kit
126	127	000	048	Symphony Kit
127	126	000	000	SFX Kit 1
128	126	000	001	SFX Kit 2

■ Expanded Voices

Voice#	Bank Select#		MIDI Program Change#	Voice Name
	MSB#	LSB#		
PIANO				
129	000	000	000	Grand Piano
130	000	001	000	Grand Piano KSP
131	000	018	000	Mellow Grand Piano
132	000	040	000	Piano Strings
133	000	041	000	Dream
134	000	000	001	Bright Piano
135	000	001	001	Bright Piano KSP
136	000	000	002	Electric Grand Piano
137	000	001	002	Electric Grand Piano KSP
138	000	032	002	Detuned CP80
139	000	040	002	Layered CP 1
140	000	041	002	Layered CP 2
141	000	000	003	Honky-tonk Piano
142	000	001	003	Honky-tonk Piano KSP
143	000	000	004	Electric Piano 1
144	000	001	004	Electric Piano 1 KSP

Voice#	Bank Select#		MIDI Program Change#	Voice Name
	MSB#	LSB#		
145	000	018	004	Mellow Electric Piano 1
146	000	032	004	Chorus Electric Piano 1
147	000	040	004	Hard Electric Piano
148	000	045	004	Velocity Crossfade Electric Piano 1
149	000	064	004	60's Electric Piano 1
150	000	000	005	Electric Piano 2
151	000	001	005	Electric Piano 2 KSP
152	000	032	005	Chorus Electric Piano 2
153	000	033	005	DX Electric Piano Hard
154	000	034	005	DX Legend
155	000	040	005	DX Phase Electric Piano
156	000	041	005	DX + Analog Electric Piano
157	000	042	005	DX Koto Electric Piano
158	000	045	005	Velocity Crossfade Electric Piano 2
159	000	000	006	Harpsichord
160	000	001	006	Harpsichord KSP
161	000	025	006	Harpsichord 2
162	000	035	006	Harpsichord 3
163	000	000	007	Clavi
164	000	001	007	Clavi KSP
165	000	027	007	Clavi Wah
166	000	064	007	Pulse Clavi
167	000	065	007	Pierce Clavi
VIBRAPHONE etc.				
168	000	000	008	Celesta
169	000	000	009	Glockenspiel
170	000	000	010	Music Box
171	000	064	010	Orgel
172	000	000	011	Vibraphone
173	000	001	011	Vibraphone KSP
174	000	045	011	Hard Vibraphone
175	000	000	012	Marimba
176	000	001	012	Marimba KSP
177	000	064	012	Sine Marimba
178	000	097	012	Balimba
179	000	098	012	Log Drums
180	000	000	013	Xylophone
181	000	000	014	Tubular Bells
182	000	096	014	Church Bells
183	000	097	014	Carillon
184	000	000	015	Dulcimer
185	000	035	015	Dulcimer 2
186	000	096	015	Cimbalom
187	000	097	015	Santur
ORGAN				
188	000	000	016	Drawbar Organ
189	000	032	016	Detuned Drawbar Organ
190	000	033	016	60's Drawbar Organ 1
191	000	034	016	60's Drawbar Organ 2
192	000	035	016	70's Drawbar Organ 1
193	000	036	016	Drawbar Organ 2
194	000	037	016	60's Drawbar Organ 3
195	000	038	016	Even Bar
196	000	040	016	"16+2""2/3"
197	000	064	016	Organ Bass
198	000	065	016	70's Drawbar Organ 2
199	000	066	016	Cheezy Organ
200	000	067	016	Drawbar Organ 3
201	000	000	017	Percussive Organ
202	000	024	017	70's Percussive Organ
203	000	032	017	Detuned Percussive Organ
204	000	033	017	Light Organ
205	000	037	017	Percussive Organ 2
206	000	000	018	Rock Organ
207	000	064	018	Rotary Organ
208	000	065	018	Slow Rotary
209	000	066	018	Fast Rotary
210	000	000	019	Church Organ
211	000	032	019	Church Organ 3
212	000	035	019	Church Organ 2
213	000	040	019	Notre Dame

Voice#	Bank Select#		MIDI Program Change#	Voice Name
	MSB#	LSB#		
214	000	064	019	Organ Flute
215	000	065	019	Tremolo Organ Flute
216	000	000	020	Reed Organ
217	000	040	020	Puff Organ
218	000	000	021	Accordion
219	000	032	021	Accord It
220	000	000	022	Hamonica
221	000	032	022	Harmonica 2
222	000	000	023	Tango Accordion
223	000	064	023	Tango Accordion 2
GUITAR				
224	000	000	024	Nylon Guitar
225	000	016	024	Nylon Guitar 2
226	000	025	024	Nylon Guitar 3
227	000	043	024	Velocity Guitar Harmonics
228	000	096	024	Ukulele
229	000	000	025	Steel Guitar
230	000	016	025	Steel Guitar 2
231	000	035	025	12-string Guitar
232	000	040	025	Nylon & Steel Guitar
233	000	041	025	Steel Guitar with Body Sound
234	000	096	025	Mandolin
235	000	000	026	Jazz Guitar
236	000	018	026	Mellow Guitar
237	000	032	026	Jazz Amp
238	000	000	027	Clean Guitar
239	000	032	027	Chorus Guitar
240	000	000	028	Muted Guitar
241	000	040	028	Funk Guitar 1
242	000	041	028	Muted Steel Guitar
243	000	043	028	Funk Guitar 2
244	000	045	028	Jazz Man
245	000	000	029	Overdriven Guitar
246	000	043	029	Guitar Pinch
247	000	000	030	Distortion Guitar
248	000	040	030	Feedback Guitar
249	000	041	030	Feedback Guitar 2
250	000	000	031	Guitar Harmonics
251	000	065	031	Guitar Feedback
252	000	066	031	Guitar Harmonics 2
BASS				
253	000	000	032	Acoustic Bass
254	000	040	032	Jazz Rhythm
255	000	045	032	Velocity Crossfade Upright Bass
256	000	000	033	Finger Bass
257	000	018	033	Finger Dark
258	000	027	033	Flange Bass
259	000	040	033	Bass & Distorted Electric Guitar
260	000	043	033	Finger Slap Bass
261	000	045	033	Finger Bass 2
262	000	065	033	Modulated Bass
263	000	000	034	Pick Bass
264	000	028	034	Muted Pick Bass
265	000	000	035	Fretless Bass
266	000	032	035	Fretless Bass 2
267	000	033	035	Fretless Bass 3
268	000	034	035	Fretless Bass 4
269	000	096	035	Synth Fretless
270	000	097	035	Smooth Fretless
271	000	000	036	Slap Bass 1
272	000	027	036	Resonant Slap
273	000	032	036	Punch Thumb Bass
274	000	000	037	Slap Bass 2
275	000	043	037	Velocity Switch Slap
276	000	000	038	Synth Bass 1
277	000	018	038	Synth Bass 1 Dark
278	000	020	038	Fast Resonant Bass
279	000	024	038	Acid Bass
280	000	035	038	Clavi Bass
281	000	040	038	Techno Synth Bass
282	000	064	038	Orbiter

Voice#	Bank Select#		MIDI Program Change#	Voice Name
	MSB#	LSB#		
283	000	065	038	Square Bass
284	000	066	038	Rubber Bass
285	000	096	038	Hammer
286	000	000	039	Synth Bass 2
287	000	006	039	Mellow Synth Bass
288	000	012	039	Sequenced Bass
289	000	018	039	Click Synth Bass
290	000	019	039	Synth Bass 2 Dark
291	000	032	039	Smooth Synth Bass
292	000	040	039	Modular Synth Bass
293	000	041	039	DX Bass
294	000	064	039	X Wire Bass
VIOLIN etc.				
295	000	000	040	Violin
296	000	008	040	Slow Violin
297	000	000	041	Viola
298	000	000	042	Cello
299	000	000	043	Contrabass
300	000	000	044	Tremolo Strings
301	000	008	044	Slow Tremolo Strings
302	000	040	044	Suspense Strings
303	000	000	045	Pizzicato Strings
304	000	000	046	Orchestral Harp
305	000	040	046	Yang Chin
306	000	000	047	Timpani
ENSEMBLE				
307	000	000	048	Strings 1
308	000	003	048	Stereo Strings
309	000	008	048	Slow Strings
310	000	024	048	Arco Strings
311	000	035	048	60's Strings
312	000	040	048	Orchestra
313	000	041	048	Orchestra 2
314	000	042	048	Tremolo Orchestra
315	000	045	048	Velocity Strings
316	000	000	049	Strings 2
317	000	003	049	Stereo Slow Strings
318	000	008	049	Legato Strings
319	000	040	049	Warm Strings
320	000	041	049	Kingdom
321	000	064	049	70's Strings
322	000	065	049	String Ensemble 3
323	000	000	050	Synth Strings 1
324	000	027	050	Resonant Strings
325	000	064	050	Synth Strings 4
326	000	065	050	Synth Strings 5
327	000	000	051	Synth Strings 2
328	000	000	052	Choir Aahs
329	000	003	052	Stereo Choir
330	000	016	052	Choir Aahs 2
331	000	032	052	Mellow Choir
332	000	040	052	Choir Strings
333	000	000	053	Voice Oohs
334	000	000	054	Synth Voice
335	000	040	054	Synth Voice 2
336	000	041	054	Choral
337	000	064	054	Analog Voice
338	000	000	055	Orchestra Hit
339	000	035	055	Orchestra Hit 2
340	000	064	055	Impact
TRUMPET etc.				
341	000	000	056	Trumpet
342	000	016	056	Trumpet 2
343	000	017	056	Bright Trumpet
344	000	032	056	Warm Trumpet
345	000	000	057	Trombone
346	000	018	057	Trombone 2
347	000	000	058	Tuba
348	000	016	058	Tuba 2
349	000	000	059	Muted Trumpet
350	000	000	060	French Horn
351	000	006	060	French Horn Solo
352	000	032	060	French Horn 2

Voice#	Bank Select#		MIDI Program Change#	Voice Name
	MSB#	LSB#		
353	000	037	060	Horn Orchestra
354	000	000	061	Brass Section
355	000	035	061	Trumpet & Trombone Section
356	000	040	061	Brass Section 2
357	000	041	061	High Brass
358	000	042	061	Mellow Brass
359	000	000	062	Synth Brass 1
360	000	012	062	Quack Brass
361	000	020	062	Resonant Synth Brass
362	000	024	062	Poly Brass
363	000	027	062	Synth Brass 3
364	000	032	062	Jump Brass
365	000	045	062	Analog Velocity Brass 1
366	000	064	062	Analog Brass 1
367	000	000	063	Synth Brass 2
368	000	018	063	Soft Brass
369	000	040	063	Synth Brass 4
370	000	041	063	Choir Brass
371	000	045	063	Analog Velocity Brass 2
372	000	064	063	Analog Brass 2
SAXOPHONE etc.				
373	000	000	064	Soprano Sax
374	000	000	065	Alto Sax
375	000	040	065	Sax Section
376	000	043	065	Hyper Alto Sax
377	000	000	066	Tenor Sax
378	000	040	066	Breathy Tenor Sax
379	000	041	066	Soft Tenor Sax
380	000	064	066	Tenor Sax 2
381	000	000	067	Baritone Sax
382	000	000	068	Oboe
383	000	000	069	English Horn
384	000	000	070	Bassoon
385	000	000	071	Clarinet
FLUTE etc.				
386	000	000	072	Piccolo
387	000	000	073	Flute
388	000	000	074	Recorder
389	000	000	075	Pan Flute
390	000	000	076	Blown Bottle
391	000	000	077	Shakuhachi
392	000	000	078	Whistle
393	000	000	079	Ocarina
SYNTH LEAD				
394	000	000	080	Square Lead
395	000	006	080	Square Lead 2
396	000	008	080	LM Square
397	000	018	080	Hollow
398	000	019	080	Shroud
399	000	064	080	Mellow
400	000	065	080	Solo Sine
401	000	066	080	Sine Lead
402	000	000	081	Sawtooth Lead
403	000	006	081	Sawtooth Lead 2
404	000	008	081	Thick Sawtooth
405	000	018	081	Dynamic Sawtooth
406	000	019	081	Digital Sawtooth
407	000	020	081	Big Lead
408	000	024	081	Heavy Synth
409	000	025	081	Waspy Synth
410	000	040	081	Pulse Sawtooth
411	000	041	081	Dr. Lead
412	000	045	081	Velocity Lead
413	000	096	081	Sequenced Analog
414	000	000	082	Calliope Lead
415	000	065	082	Pure Pad
416	000	000	083	Chiff Lead
417	000	064	083	Rubby
418	000	000	084	Charang Lead
419	000	064	084	Distorted Lead
420	000	065	084	Wire Lead
421	000	000	085	Voice Lead
422	000	024	085	Synth Aahs

Voice#	Bank Select#		MIDI Program Change#	Voice Name
	MSB#	LSB#		
423	000	064	085	Vox Lead
424	000	000	086	Fifths Lead
425	000	035	086	Big Five
426	000	000	087	Bass & Lead
427	000	016	087	Big & Low
428	000	064	087	Fat & Perky
429	000	065	087	Soft Whirl
SYNTH PAD				
430	000	000	088	New Age Pad
431	000	064	088	Fantasy
432	000	000	089	Warm Pad
433	000	016	089	Thick Pad
434	000	017	089	Soft Pad
435	000	018	089	Sine Pad
436	000	064	089	Horn Pad
437	000	065	089	Rotary Strings
438	000	000	090	Poly Synth Pad
439	000	064	090	Poly Pad 80
440	000	065	090	Click Pad
441	000	066	090	Analog Pad
442	000	067	090	Square Pad
443	000	000	091	Choir Pad
444	000	064	091	Heaven
445	000	066	091	Itopia
446	000	067	091	CC Pad
447	000	000	092	Bowed Pad
448	000	064	092	Glacier
449	000	065	092	Glass Pad
450	000	000	093	Metallic Pad
451	000	064	093	Tine Pad
452	000	065	093	Pan Pad
453	000	000	094	Halo Pad
454	000	000	095	Sweep Pad
455	000	020	095	Shwimmer
456	000	027	095	Converge
457	000	064	095	Polar Pad
458	000	066	095	Celestial
SYNTH EFFECT				
459	000	000	096	Rain
460	000	045	096	Clavi Pad
461	000	064	096	Harmo Rain
462	000	065	096	African Wind
463	000	066	096	Carib
464	000	000	097	Sound Track
465	000	027	097	Prologue
466	000	064	097	Ancestral
467	000	000	098	Crystal
468	000	012	098	Synth Drum Comp
469	000	014	098	Popcorn
470	000	018	098	Tiny Bells
471	000	035	098	Round Glockenspiel
472	000	040	098	Glockenspiel Chimes
473	000	041	098	Clear Bells
474	000	042	098	Chorus Bells
475	000	064	098	Synth Mallet
476	000	065	098	Soft Crystal
477	000	066	098	Loud Glockenspiel
478	000	067	098	Christmas Bells
479	000	068	098	Vibraphone Bells
480	000	069	098	Digital Bells
481	000	070	098	Air Bells
482	000	071	098	Bell Harp
483	000	072	098	Gamelimba
484	000	000	099	Atmosphere
485	000	018	099	Warm Atmosphere
486	000	019	099	Hollow Release
487	000	040	099	Nylon Electric Piano
488	000	064	099	Nylon Harp
489	000	065	099	Harp Vox
490	000	066	099	Atmosphere Pad
491	000	067	099	Planet
492	000	000	100	Brightness
493	000	064	100	Fantasy Bells

Voice#	Bank Select#		MIDI Program Change#	Voice Name
	MSB#	LSB#		
494	000	096	100	Smokey
495	000	000	101	Goblins
496	000	064	101	Goblins Synth
497	000	065	101	Creepier
498	000	066	101	Ring Pad
499	000	067	101	Ritual
500	000	068	101	To Heaven
501	000	070	101	Night
502	000	071	101	Glisten
503	000	096	101	Bell Choir
504	000	000	102	Echoes
505	000	008	102	Echoes 2
506	000	014	102	Echo Pan
507	000	064	102	Echo Bells
508	000	065	102	Big Pan
509	000	066	102	Synth Piano
510	000	067	102	Creation
511	000	068	102	Star Dust
512	000	069	102	Resonant & Panning
513	000	000	103	Sci-Fi
514	000	064	103	Starz
ETHNIC				
515	000	000	104	Sitar
516	000	032	104	Detuned Sitar
517	000	035	104	Sitar 2
518	000	096	104	Tambra
519	000	097	104	Tamboura
520	000	000	105	Banjo
521	000	028	105	Muted Banjo
522	000	096	105	Rabab
523	000	097	105	Gopichant
524	000	098	105	Oud
525	000	000	106	Shamisen
526	000	000	107	Koto
527	000	096	107	Taisho-kin
528	000	097	107	Kanoon
529	000	000	108	Kalimba
530	000	000	109	Bagpipe
531	000	000	110	Fiddle
532	000	000	111	Shanai
533	000	064	111	Shanai 2
534	000	096	111	Pungi
535	000	097	111	Hichiriki
PERCUSSION				
536	000	000	112	Tinkle Bell
537	000	096	112	Bonang
538	000	097	112	Altair
539	000	098	112	Gamelan Gongs
540	000	099	112	Stereo Gamelan Gongs
541	000	100	112	Rama Cymbal
542	000	101	112	Asian Bells
543	000	000	113	Agogo
544	000	000	114	Steel Drums
545	000	097	114	Glass Percussion
546	000	098	114	Thai Bells
547	000	000	115	Woodblock
548	000	096	115	Castanets
549	000	000	116	Taiko Drum
550	000	096	116	Gran Cassa
551	000	000	117	Melodic Tom
552	000	064	117	Melodic Tom 2
553	000	065	117	Real Tom
554	000	066	117	Rock Tom
555	000	000	118	Synth Drum
556	000	064	118	Analog Tom
557	000	065	118	Electronic Percussion
558	000	000	119	Reverse Cymbal
SOUND EFFECT				
559	000	000	120	Fret Noise
560	000	000	121	Breath Noise
561	000	000	122	Seashore
562	000	000	123	Bird Tweet
563	000	000	124	Telephone Ring

Voice#	Bank Select#		MIDI Program Change#	Voice Name
	MSB#	LSB#		
564	000	000	125	Helicopter
565	000	000	126	Applause
566	000	000	127	Gunshot
SFX				
567	064	000	000	Cutting Noise
568	064	000	001	Cutting Noise 2
569	064	000	003	String Slap
570	064	000	016	Flute Key Click
571	064	000	032	Shower
572	064	000	033	Thunder
573	064	000	034	Wind
574	064	000	035	Stream
575	064	000	036	Bubble
576	064	000	037	Feed
577	064	000	048	Dog
578	064	000	049	Horse
579	064	000	050	Bird Tweet 2
580	064	000	054	Ghost
581	064	000	055	Maou
582	064	000	064	Phone Call
583	064	000	065	Door Squeak
584	064	000	066	Door Slam
585	064	000	067	Scratch Cut
586	064	000	068	Scratch Split
587	064	000	069	Wind Chime
588	064	000	070	Telephone Ring 2
589	064	000	080	Car Engine Ignition
590	064	000	081	Car Tires Squeal
591	064	000	082	Car Passing
592	064	000	083	Car Crash
593	064	000	084	Siren
594	064	000	085	Train
595	064	000	086	Jet Plane
596	064	000	087	Starship
597	064	000	088	Burst
598	064	000	089	Roller Coaster
599	064	000	090	Submarine
600	064	000	096	Laugh
601	064	000	097	Scream
602	064	000	098	Punch
603	064	000	099	Heartbeat
604	064	000	100	Footsteps
605	064	000	112	Machine Gun
606	064	000	113	Laser Gun
607	064	000	114	Explosion
608	064	000	115	Firework

■ ABC/DoReMi Voices

Voice#	Bank Select#		MIDI Program Change#	Voice Name
	MSB#	LSB#		
609	000	112	126	ABC (Oboe)
610	000	112	127	DoReMi (Oboe)

Style List

No.	Style Name
8 beat	
1	8 Beat 1
2	8 Beat 2
3	8 Beat Adria
4	8 Beat Pop 1
5	British Pop
6	8 Beat Soft
16 beat	
7	16 Beat 1
8	16 Beat 2
9	16 Beat 3
10	Soft Fusion
11	Hip Hop Pop
12	Cool Dance
13	16 Beat Funk
14	Funky Pop
15	16 Beat 4
Ballad	
16	Piano Ballad
17	U.S. Ballad
18	Slow Rock
19	Modern 6/8
20	Guitar Ballad
21	Organ Ballad
22	Epic Ballad
23	16 Beat Ballad
24	Rock Ballad
25	Slow Ballad
26	Pop Ballad
Rock	
27	Rock 1
28	Hard Rock
29	Rock & Roll
30	Twist
31	4/4 Blues
32	6/8 Rock
Dance	
33	House
34	Eurobeat
35	Euro House
36	Trance
37	Clubdance
38	Techno
39	Hip Hop
40	Groundbeat
41	90's Disco
42	70's Disco
43	Disco Chocolate

No.	Style Name
44	Disco Funk
45	Disco Fox
46	Disco Party
47	Disco Latin
Swing & Jazz	
48	Swing
49	Big Band 1
50	Big Band Ballad
51	Jazz Ballad
52	Jazz Trio
53	Boogie
54	Bebop
55	Big Band 2
56	Dixieland
Rhythm & Blues	
57	Gospel Shuffle
58	R & B
59	Motown
60	Soul Shuffle
61	6/8 Blues
Country	
62	Country Rock
63	Country 8 Beat
64	Country Pop
65	Country Swing
66	Bluegrass
67	Country Ballad
Latin	
68	Samba Rio
69	Bossa Nova
70	Espanole
71	Swing Reggae
72	Salsa
73	Mambo
Ballroom	
74	Slow Fox
75	Quickstep
76	Tango
77	Cha Cha Cha
78	Samba
79	Rhumba
80	Pasodoble
81	Jive
82	Beguine
83	Foxtrot
March & Waltz	
84	U.S. March
85	German March

No.	Style Name
86	6/8 March
87	Polka Pop
88	PolkaOberkrainer
89	Jazz Waltz
90	Country Waltz
91	Vienna Waltz
92	Slow Waltz
93	Orch. Waltz
94	WaltzOberkrainer
95	Musette
96	Guitar Waltz
Pianist	
97	Stride
98	Boogie
99	Swing
100	Pianoman
101	Ballad
102	Ragtime
103	March
104	6/8 March
105	Waltz
106	Jazz Waltz

Drum Kit List

- * “←” indicates that the drum sound is the same as “Standard Kit 1”.
- * Each percussion voice uses one note.
- * The MIDI Note # and Note are actually one octave lower than listed. For example, in “117: Standard Kit 1”, the “Seq Click H” (Note# 36/Note C1) corresponds to (Note# 24/Note C0).

Voice No.				117	118	119	120
MSB/LSB/PC				127/000/000	127/000/001	127/000/008	127/000/16
Keyboard		MIDI		Standard Kit 1	Standard Kit 2	Room Kit	Rock Kit
Note#	Note	Note#	Note				
25	C#0	13	C#-1	Surdo Mute	←	←	←
26	D0	14	D-1	Surdo Open	←	←	←
27	D#0	15	D#-1	Hi Q	←	←	←
28	E0	16	E-1	Whip Slap	←	←	←
29	F0	17	F-1	Scratch Push	←	←	←
30	F#0	18	F#-1	Scratch Pull	←	←	←
31	G0	19	G-1	Finger Snap	←	←	←
32	G#0	20	G#-1	Click Noise	←	←	←
33	A0	21	A-1	Metronome Click	←	←	←
34	A#0	22	A#-1	Metronome Bell	←	←	←
35	B0	23	B-1	Seq Click L	←	←	←
36	C1	24	C0	Seq Click H	←	←	←
37	C#1	25	C#0	Brush Tap	←	←	←
38	D1	26	D0	Brush Swirl	←	←	←
39	D#1	27	D#0	Brush Slap	←	←	←
40	E1	28	E0	Brush Tap Swirl	←	←	←
41	F1	29	F0	Snare Roll	←	←	←
42	F#1	30	F#0	Castanet	←	←	←
43	G1	31	G0	Snare H Soft	Snare H Soft 2	←	SD Rock H
44	G#1	32	G#0	Sticks	←	←	←
45	A1	33	A0	Bass Drum Soft	←	←	←
46	A#1	34	A#0	Open Rim Shot	Open Rim Shot 2	←	←
47	B1	35	B0	Bass Drum Hard	←	←	Bass Drum H
48	C2	36	C1	Bass Drum	Bass Drum 2	←	BD Rock
49	C#2	37	C#1	Side Stick	←	←	←
50	D2	38	D1	Snare M	Snare M 2	SD Room L	SD Rock L
51	D#2	39	D#1	Hand Clap	←	←	←
52	E2	40	E1	Snare H Hard	Snare H Hard 2	SD Room H	SD Rock Rim
53	F2	41	F1	Floor Tom L	←	Room Tom 1	Rock Tom 1
54	F#2	42	F#1	Hi-Hat Closed	←	←	←
55	G2	43	G1	Floor Tom H	←	Room Tom 2	Rock Tom 2
56	G#2	44	G#1	Hi-Hat Pedal	←	←	←
57	A2	45	A1	Low Tom	←	Room Tom 3	Rock Tom 3
58	A#2	46	A#1	Hi-Hat Open	←	←	←
59	B2	47	B1	Mid Tom L	←	Room Tom 4	Rock Tom 4
60	C3	48	C2	Mid Tom H	←	Room Tom 5	Rock Tom 5
61	C#3	49	C#2	Crash Cymbal 1	←	←	←
62	D3	50	D2	High Tom	←	Room Tom 6	Rock Tom 6
63	D#3	51	D#2	Ride Cymbal 1	←	←	←
64	E3	52	E2	Chinese Cymbal	←	←	←
65	F3	53	F2	Ride Cymbal Cup	←	←	←
66	F#3	54	F#2	Tambourine	←	←	←

Voice No.				117	118	119	120
MSB/LSB/PC				127/000/000	127/000/001	127/000/008	127/000/16
Keyboard		MIDI		Standard Kit 1	Standard Kit 2	Room Kit	Rock Kit
Note#	Note	Note#	Note				
67	G3	55	G2	Splash Cymbal	←	←	←
68	G#3	56	G#2	Cowbell	←	←	←
69	A3	57	A2	Crash Cymbal 2	←	←	←
70	A#3	58	A#2	Vibraslap	←	←	←
71	B3	59	B2	Ride Cymbal 2	←	←	←
72	C4	60	C3	Bongo H	←	←	←
73	C#4	61	C#3	Bongo L	←	←	←
74	D4	62	D3	Conga H Mute	←	←	←
75	D#4	63	D#3	Conga H Open	←	←	←
76	E4	64	E3	Conga L	←	←	←
77	F4	65	F3	Timbale H	←	←	←
78	F#4	66	F#3	Timbale L	←	←	←
79	G4	67	G3	Agogo H	←	←	←
80	G#4	68	G#3	Agogo L	←	←	←
81	A4	69	A3	Cabasa	←	←	←
82	A#4	70	A#3	Maracas	←	←	←
83	B4	71	B3	Samba Whistle H	←	←	←
84	C5	72	C4	Samba Whistle L	←	←	←
85	C#5	73	C#4	Guiro Short	←	←	←
86	D5	74	D4	Guiro Long	←	←	←
87	D#5	75	D#4	Claves	←	←	←
88	E5	76	E4	Wood Block H	←	←	←
89	F5	77	F4	Wood Block L	←	←	←
90	F#5	78	F#4	Cuica Mute	←	←	←
91	G5	79	G4	Cuica Open	←	←	←
92	G#5	80	G#4	Triangle Mute	←	←	←
93	A5	81	A4	Triangle Open	←	←	←
94	A#5	82	A#4	Shaker	←	←	←
95	B5	83	B4	Jingle Bell	←	←	←
96	C6	84	C5	Bell Tree	←	←	←

Voice No.				121	122	123	124
MSB/LSB/PC				127/000/24	127/000/25	127/000/27	127/000/32
Keyboard		MIDI		Electronic Kit	Analog Kit	Dance Kit	Jazz Kit
Note#	Note	Note#	Note				
25	C#0	13	C#-1	←	←	←	←
26	D0	14	D-1	←	←	←	←
27	D#0	15	D#-1	←	←	←	←
28	E0	16	E-1	←	←	←	←
29	F0	17	F-1	←	←	←	←
30	F#0	18	F#-1	←	←	←	←
31	G0	19	G-1	←	←	←	←
32	G#0	20	G#-1	←	←	←	←
33	A0	21	A-1	←	←	←	←
34	A#0	22	A#-1	←	←	←	←
35	B0	23	B-1	←	←	←	←
36	C1	24	C0	←	←	←	←
37	C#1	25	C#0	←	←	←	←
38	D1	26	D0	←	←	←	←
39	D#1	27	D#0	←	←	←	←
40	E1	28	E0	Reverse Cymbal	Reverse Cymbal	Reverse Cymbal	←
41	F1	29	F0	←	←	←	←
42	F#1	30	F#0	Hi Q 2	Hi Q 2	Hi Q 2	←

Voice No.				121	122	123	124
MSB/LSB/PC				127/000/24	127/000/25	127/000/27	127/000/32
Keyboard		MIDI		Electronic Kit	Analog Kit	Dance Kit	Jazz Kit
Note#	Note	Note#	Note				
43	G1	31	G0	Snare L	SD Rock H	AnSD Snappy	SD Jazz H Light
44	G#1	32	G#0	←	←	←	←
45	A1	33	A0	Bass Drum H	Bass Drum H	AnBD Dance-1	←
46	A#1	34	A#0	←	←	←	←
47	B1	35	B0	BD Rock	BD Analog L	AnBD Dance-2	←
48	C2	36	C1	BD Gate	BD Analog H	AnBD Dance-3	BD Jazz
49	C#2	37	C#1	←	Analog Side Stick	Analog Side Stick	←
50	D2	38	D1	SD Rock L	Analog Snare 1	AnSD Q	SD Jazz L
51	D#2	39	D#1	←	←	←	←
52	E2	40	E1	SD Rock H	Analog Snare 2	AnSD Ana+Acoustic	SD Jazz M
53	F2	41	F1	E Tom 1	Analog Tom 1	Analog Tom 1	Jazz Tom 1
54	F#2	42	F#1	←	Analog HH Closed 1	Analog HH Closed 3	←
55	G2	43	G1	E Tom 2	Analog Tom 2	Analog Tom 2	Jazz Tom 2
56	G#2	44	G#1	←	Analog HH Closed 2	Analog HH Closed 4	←
57	A2	45	A1	E Tom 3	Analog Tom 3	Analog Tom 3	Jazz Tom 3
58	A#2	46	A#1	←	Analog HH Open	Analog HH Open 2	←
59	B2	47	B1	E Tom 4	Analog Tom 4	Analog Tom 4	Jazz Tom 4
60	C3	48	C2	E Tom 5	Analog Tom 5	Analog Tom 5	Jazz Tom 5
61	C#3	49	C#2	←	Analog Cymbal	Analog Cymbal	←
62	D3	50	D2	E Tom 6	Analog Tom 6	Analog Tom 6	Jazz Tom 6
63	D#3	51	D#2	←	←	←	←
64	E3	52	E2	←	←	←	←
65	F3	53	F2	←	←	←	←
66	F#3	54	F#2	←	←	←	←
67	G3	55	G2	←	←	←	←
68	G#3	56	G#2	←	Analog Cowbell	Analog Cowbell	←
69	A3	57	A2	←	←	←	←
70	A#3	58	A#2	←	←	←	←
71	B3	59	B2	←	←	←	←
72	C4	60	C3	←	←	←	←
73	C#4	61	C#3	←	←	←	←
74	D4	62	D3	←	Analog Conga H	Analog Conga H	←
75	D#4	63	D#3	←	Analog Conga M	Analog Conga M	←
76	E4	64	E3	←	Analog Conga L	Analog Conga L	←
77	F4	65	F3	←	←	←	←
78	F#4	66	F#3	←	←	←	←
79	G4	67	G3	←	←	←	←
80	G#4	68	G#3	←	←	←	←
81	A4	69	A3	←	←	←	←
82	A#4	70	A#3	←	Analog Maracas	Analog Maracas	←
83	B4	71	B3	←	←	←	←
84	C5	72	C4	←	←	←	←
85	C#5	73	C#4	←	←	←	←
86	D5	74	D4	←	←	←	←
87	D#5	75	D#4	←	Analog Claves	Analog Claves	←
88	E5	76	E4	←	←	←	←
89	F5	77	F4	←	←	←	←
90	F#5	78	F#4	Scratch Push	Scratch Push	Scratch Push	←
91	G5	79	G4	Scratch Pull	Scratch Pull	Scratch Pull	←
92	G#5	80	G#4	←	←	←	←
93	A5	81	A4	←	←	←	←
94	A#5	82	A#4	←	←	←	←
95	B5	83	B4	←	←	←	←
96	C6	84	C5	←	←	←	←

Voice No.				125	126	127	128
MSB/LSB/PC				127/000/40	127/000/48	126/000/000	126/000/001
Keyboard		MIDI		Brush Kit	Symphonic Kit	SFX Kit 1	SFX Kit 2
Note#	Note	Note#	Note				
25	C#0	13	C#-1	←	←		
26	D0	14	D-1	←	←		
27	D#0	15	D#-1	←	←		
28	E0	16	E-1	←	←		
29	F0	17	F-1	←	←		
30	F#0	18	F#-1	←	←		
31	G0	19	G-1	←	←		
32	G#0	20	G#-1	←	←		
33	A0	21	A-1	←	←		
34	A#0	22	A#-1	←	←		
35	B0	23	B-1	←	←		
36	C1	24	C0	←	←		
37	C#1	25	C#0	←	←		
38	D1	26	D0	←	←		
39	D#1	27	D#0	←	←		
40	E1	28	E0	←	←		
41	F1	29	F0	←	←		
42	F#1	30	F#0	←	←		
43	G1	31	G0	Brush Slap L	←		
44	G#1	32	G#0	←	←		
45	A1	33	A0	←	Bass Drum L		
46	A#1	34	A#0	←	←		
47	B1	35	B0	←	Gran Cassa		
48	C2	36	C1	BD Jazz	Gran Cassa Mute	Cutting Noise	Phone Call
49	C#2	37	C#1	←	←	Cutting Noise 2	Door Squeak
50	D2	38	D1	Brush Slap	Marching Sn M		Door Slam
51	D#2	39	D#1	←	←	String Slap	Scratch Cut
52	E2	40	E1	Brush Tap	Marching Sn H		Scratch
53	F2	41	F1	Brush Tom 1	Jazz Tom 1		Wind Chime
54	F#2	42	F#1	←	←		Telephone Ring 2
55	G2	43	G1	Brush Tom 2	Jazz Tom 2		
56	G#2	44	G#1	←	←		
57	A2	45	A1	Brush Tom 3	Jazz Tom 3		
58	A#2	46	A#1	←	←		
59	B2	47	B1	Brush Tom 4	Jazz Tom 4		
60	C3	48	C2	Brush Tom 5	Jazz Tom 5		
61	C#3	49	C#2	←	Hand Cym. L		
62	D3	50	D2	Brush Tom 6	Jazz Tom 6		
63	D#3	51	D#2	←	Hand Cym.Short L		
64	E3	52	E2	←	←	Flute Key Click	Car Engine Ignition
65	F3	53	F2	←	←		Car Tires Squeal
66	F#3	54	F#2	←	←		Car Passing
67	G3	55	G2	←	←		Car Crash
68	G#3	56	G#2	←	←		Siren
69	A3	57	A2	←	Hand Cym. H		Train
70	A#3	58	A#2	←	←		Jet Plane
71	B3	59	B2	←	Hand Cym.Short H		Starship
72	C4	60	C3	←	←		Burst
73	C#4	61	C#3	←	←		Roller Coaster
74	D4	62	D3	←	←		Submarine
75	D#4	63	D#3	←	←		
76	E4	64	E3	←	←		
77	F4	65	F3	←	←		
78	F#4	66	F#3	←	←		

Voice No.				125	126	127	128
MSB/LSB/PC				127/000/40	127/000/48	126/000/000	126/000/001
Keyboard		MIDI		Brush Kit	Symphonic Kit	SFX Kit 1	SFX Kit 2
Note#	Note	Note#	Note				
79	G4	67	G3	←	←		
80	G#4	68	G#3	←	←	Shower	Laugh
81	A4	69	A3	←	←	Thunder	Scream
82	A#4	70	A#3	←	←	Wind	Punch
83	B4	71	B3	←	←	Stream	Heartbeat
84	C5	72	C4	←	←	Bubble	FootSteps
85	C#5	73	C#4	←	←	Feed	
86	D5	74	D4	←	←		
87	D#5	75	D#4	←	←		
88	E5	76	E4	←	←		
89	F5	77	F4	←	←		
90	F#5	78	F#4	←	←		
91	G5	79	G4	←	←		
92	G#5	80	G#4	←	←		
93	A5	81	A4	←	←		
94	A#5	82	A#4	←	←		
95	B5	83	B4	←	←		
96	C6	84	C5	←	←	Dog	Machine Gun
97	C#6	85	C#5			Horse	Laser Gun
98	D6	86	D5			Bird Tweet 2	Explosion
99	D#6	87	D#5				Firework
100	E6	88	E5				
101	F6	89	F5				
102	F#6	90	F#5			Ghost	
103	G6	91	G5			Maou	

Effect Type List

■ Reverb Types





















No.	Reverb Type	Display Name	Description
1	Hall 1	Hall1	Concert hall reverb.
2	Hall 2	Hall2	
3	Room 1	Room1	Small room reverb.
4	Room 2	Room2	
5	Stage 1	Stage1	Reverb for solo instruments.
6	Stage 2	Stage2	
7	Plate 1	Plate1	Simulated steel plate reverb.
8	Plate 2	Plate2	
9	Off	Off	No effect.

■ DSP Types

No.	DSP Type	Display Name	Description
1	Hall 1	Hall1	Concert hall reverb.
2	Hall 2	Hall2	
3	Room 1	Room1	Small room reverb.
4	Room 2	Room2	
5	Stage 1	Stage1	Reverb for solo instruments.
6	Stage 2	Stage2	
7	Plate 1	Plate1	Simulated steel plate reverb.
8	Plate 2	Plate2	
9	Early Reflection 1	ER1	Early reflections only.
10	Early Reflection 2	ER2	
11	Gate Reverb	Gate1	Gated reverb effect, in which the reverberation is quickly cut off for special effects.
12	Reverse Gate	Gate2	Similar to Gate Reverb, but with a reverse increase in reverb.
13	Chorus 1	Chorus1	Conventional chorus effect with rich, warm chorusing.
14	Chorus 2	Chorus2	
15	Flanger 1	Flanger1	Pronounced three-phase modulation with slight metallic sound.
16	Flanger 2	Flanger2	
17	Symphonic	Symphony	Exceptionally rich & deep chorusing.
18	Phaser	Phaser	Pronounced, metallic modulation with periodic phase change.
19	Rotary Speaker 1	Rotary1	Rotary speaker simulation.
20	Rotary Speaker 2	Rotary2	
21	Tremolo 1	Tremolo1	Rich Tremolo effect with both volume and pitch modulation.
22	Tremolo 2	Tremolo2	
23	Guitar Tremolo	Guitar Tremolo	Simulated electric guitar tremolo.
24	Auto Pan	Auto Pan	Several panning effects that automatically shift the sound position (left, right, front, back).
25	Auto Wah	Auto Wah	Repeating filter sweep "wah" effect.
26	Delay Left - Center - Right	DelayLCR	Three independent delays, for the left, right and center stereo positions.
27	Delay Left - Right	DelayLR	Initial delay for each stereo channel, and two separate feedback delays.
28	Echo	Echo	Stereo delay, with independent feedback level settings for each channel.
29	Cross Delay	CrossDly	Complex effect that sends the delayed repeats "bouncing" between the left and right channels.
30	Karaoke	Karaoke	Deep, pronounced echo effect.
31	Distortion Hard	D Hard	Hard-edged, warm distortion.
32	Distortion Soft	D Soft	Soft, warm distortion.
33	Overdrive	Overdrv	Natural distortion, like that of an overdriven amplifier.
34	Amp Simulation	AmpSimu	Characteristic sound of a guitar amplifier/speaker.

No.	DSP Type	Display Name	Description
35	EQ Disco	EQ Disco	Equalizer effect that boosts both high and low frequencies, as is typical in most disco music.
36	EQ Telephone	EQ Tel	Equalizer effect that cuts both high and low frequencies, to simulate the sound heard through a telephone receiver.
37	3Band EQ	3BandEQ	Equalizer with three separate frequency bands.
38	2Band EQ	2BandEQ	Equalizer with two separate frequency bands.
39	No Effect	Off	No effect

■ Harmony Types

No.	Harmony Type	Display Name	Description	
1	Duet	Duet	Harmony types 1–5 are pitch-based and add one-, two- or three-note harmonies to the single-note melody played in the right hand. These types only sound when chords are played in the auto accompaniment section of the keyboard.	
2	Trio	Trio		
3	Block	Block		
4	Country	Country		
5	Octave	Octave		
6	Trill 1/4 note	Tril1/4		Types 6 - 26 are rhythm-based effects and add embellishments or delayed repeats in time with the auto accompaniment. These types sound whether the auto accompaniment is on or not; however, the actual speed of the effect depends on the Tempo setting (page 54). The individual note values in each type let you synchronize the effect precisely to the rhythm. Triplet settings are also available: 1/6 = quarter-note triplets, 1/12 = eighth-note triplets, 1/24 = sixteenth-note triplets. <ul style="list-style-type: none"> The Trill effect Types (6–12) create two-note trills (alternating notes) when two notes are held. The Tremolo effect Types (13–19) repeat all held notes (up to four). The Echo effect Types (20–26) create delayed repeats of each note played.
7	Trill 1/6 note	Tril1/6		
8	Trill 1/8 note	Tril1/8		
9	Trill 1/12 note	Tril1/12		
10	Trill 1/16 note	Tril1/16		
11	Trill 1/24 note	Tril1/24		
12	Trill 1/32 note	Tril1/32		
13	Tremolo 1/4 note	Trem1/4		
14	Tremolo 1/6 note	Trem1/6		
15	Tremolo 1/8 note	Trem1/8		
16	Tremolo 1/12 note	Trem1/12		
17	Tremolo 1/16 note	Trem1/16		
18	Tremolo 1/24 note	Trem1/24		
19	Tremolo 1/32 note	Trem1/32		
20	Echo 1/4 note	Echo1/4		
21	Echo 1/6 note	Echo1/6		
22	Echo 1/8 note	Echo1/8		
23	Echo 1/12 note	Echo1/12		
24	Echo 1/16 note	Echo1/16		
25	Echo 1/24 note	Echo1/24		
26	Echo 1/32 note	Echo1/32		

Prog Change : True #	o 0 - 127 *****	o 0 - 127	
System Exclusive	o *3	o *3	
: Song Pos.	x	x	
: Song Sel.	x	x	
: Tune	x	x	
System : Clock	o	o	
Real Time: Commands	o *4	o *4	
Aux :All Sound OFF	x	o(120,126,127)	
:Reset All Cntrls	x	o(121)	
:Local ON/OFF	x	o(122)	*5
:All Notes OFF	x	o(123-125)	
Mes- :Active Sense	o	o	
sages:Reset	x	x	

Mode 1 : OMNI ON , POLY Mode 2 : OMNI ON , MONO o : Yes
Mode 3 : OMNI OFF, POLY Mode 4 : OMNI OFF, MONO x : No

NOTE:

*1 By default (factory settings) the EZ-30 ordinarily functions as a 16-channel multi-timbral tone generator, and incoming data does not affect the panel voices or panel settings. However, the MIDI messages listed below do affect the panel voices, auto accompaniment, and songs.

- MIDI Master Tuning
- System exclusive messages for changing the Reverb Type, Chorus Type, and DSP Type.

*2 Messages for these control change numbers cannot be transmitted from the EZ-30 itself. However, they may be transmitted when playing the accompaniment, song or using the Harmony effect.

*3 Exclusive

<GM System ON> F0H, 7EH, 7FH, 09H, 01H, F7H

- This message automatically restores all default settings for the instrument, with the exception of MIDI Master Tuning.

<MIDI Master Volume> F0H, 7FH, 7FH, 04H, 01H, ll, mm, F7H

- This message allows the volume of all channels to be changed simultaneously (Universal System Exclusive).
- The values of "mm" is used for MIDI Master Tuning. (Values for "ll" are ignored.)

<MIDI Master Tuning> F0H, 43H, 1nH, 27H, 30H, 00H, 00H, mm, ll, cc, F7H

- This message simultaneously changes the tuning value of all channels.
- The values of "mm" and "ll" are used for MIDI Master Tuning.
- The default value of "mm" and "ll" are 08H and 00H, respectively. Any values can be used for "n" and "cc."

<Reverb Type> F0H, 43H, 1nH, 4CH, 02H, 01H, 00H, mmH, llH, F7H

- mm : Reverb Type MSB
- ll : Reverb Type LSB

Refer to the Effect Map (page 101) for details.

<Chorus Type> F0H, 43H, 1nH, 4CH, 02H, 01H, 20H, mmH, llH, F7H

- mm : Chorus Type MSB
- ll : Chorus Type LSB

Refer to the Effect Map (page 101) for details.

<DSP Type> F0H, 43H, 1nH, 4CH, 02H, 01H, 40H, mmH, llH, F7H

- mm : DSP Type MSB
- ll : DSP Type LSB

Refer to the Effect Map (page 101) for details.

<DRY Level> F0H, 43H, 1nH, 4CH, 08H, 0mH, 11H, llH, F7H

- ll : Dry Level
- 0m : Channel Number

*4 When the accompaniment is started, an FAH message is transmitted. When accompaniment is stopped, an FCH message is transmitted. When the clock is set to External, both FAH (accompaniment start) and FCH (accompaniment stop) are recognized.

*5 Local ON/OFF

<Local ON> Bn, 7A, 7F

<Local OFF> Bn, 7A, 00

Value for "n" is ignored.

■ Effect map

- * If the received value does not contain an effect type in the TYPE LSB, the LSB will be directed to TYPE 0.
- * The numbers in parentheses in front of the Effect Type names correspond to the number indicated in the display.
- * By using an external sequencer, which is capable of editing and transmitting the system exclusive messages and parameter changes, you can select the Reverb, Chorus and DSP effect types which are not accessible from the EZ-30 panel itself. When one of the effects is selected by the external sequencer, “ - ” will be shown on the display.

● REVERB

TYPE MSB	TYPE LSB								
	00	01	02	08	16	17	18	19	20
000	No Effect								
001	(1)Hall1					(2)Hall2			
002	Room					(3)Room1		(4)Room2	
003	Stage				(5)Stage1	(6)Stage2			
004	Plate				(7)Plate1	(8)Plate2			
005...127	No Effect								

● CHORUS

TYPE MSB	TYPE LSB								
	00	01	02	08	16	17	18	19	20
000...064	No Effect								
065	Chorus		Chorus2						
066	Celeste					Chorus1			
067	Flanger			Flanger1		Flanger2			
068...127	No Effect								

● DSP

TYPE MSB	TYPE LSB								
	00	01	02	08	16	17	18	19	20
000	No Effect								
001	(1)Hall1					(2)Hall2			
002	Room					(3)Room1		(4)Room2	
003	Stage				(5)Stage1	(6)Stage2			
004	Plate				(7)Plate1	(8)Plate2			
005	Delay L,C,R				(26)Delay L,C,R				
006	(27)Delay L,R								
007	(28)Echo								
008	(29)Cross Delay								
009	(9)Early Reflection1	(10)Early Reflection2							
010	(11)Gate Reverb								
011	(12)Reverse Gate								
012...019	No Effect								
020	(30)Karaoke								
021...064	No Effect								
065	Chorus		(14)Chorus2						
066	Celeste					(13)Chorus1			
067	Flanger			(15)Flanger1		(16)Flanger2			
068	Symphonic				(17)Symphonic				
069	Rotary Speaker				(19)Rotary Speaker1				
070	Tremolo				(21)Tremolo1				
071	Auto Pan				(24)Auto Pan		(20)Rotary Speaker2	(22)Tremolo2	(23)Guitar Tremolo
072	(18)Phaser								
073	Distortion								
074	(33)Overdrive								
075	(34)Amp Simulation				(31)Distortion Hard	(32)Distortion Soft			
076	(36)3Band EQ					(35)EQ Telephone			
077	(37)2Band EQ								
078	Auto Wah				(25)Auto Wah				
079...127	No Effect								

Specifications

Keyboards

- 61 standard-size keys (C1–C6), with Touch Response and Light Guide

Display

- Large multi-function LCD display (backlit)

Setup

- STANDBY/ON
- MASTER VOLUME : MIN - MAX

Panel Controls

- OVERALL (L, R), SONG, VOICE, STYLE, PORTABLE GRAND, METRONOME, ABC/DoReMi, [0]–[9], [+] (YES), [–] (NO), DEMO, TOUCH, HARMONY, Dict., L, R, TEMPO/TAP

Voice

- 610 voices (including 480 Expanded voices)
- Polyphony : 32

Auto Accompaniment

- 106 styles
- Accompaniment Control : ACMP ON/OFF, SYNC STOP, SYNC START, START/STOP, INTRO/ENDING, MAIN A/B (AUTO FILL)
- Fingering : Multi fingering
- Accompaniment Volume

Yamaha Educational Suite

- Dictionary
- Lesson 1–3

One Touch Setting

- Voice (for each style or song)

Overall controls

- Octave
- Transpose
- Tuning
- Accompaniment Volume
- Song Volume
- Metronome Volume
- MIDI
- Light
- ABC/DoReMi
- Reverb
- DSP
- Harmony
- Grade
- Talking

Effects

- Reverb : 8 types
- DSP : 37 types
- Harmony : 26 types

Song

- 100 Songs + 5 User Songs + max. 99 Flash Songs (Up to 488 KB)
- Song Clear, Track Clear

Recording

- Song
 - User Song : 5 Songs
 - Real Time Recording
 - Recording Tracks : 1, 2, 3, 4, 5, CHORD
- Flash Memory
 - Flash Song : max. 99 Songs
 - Memory size: 488 KB

MIDI

- Initial Send
- Local Control
- Bulk Dump

Auxiliary jacks

- PHONES/OUTPUT, DC IN 10-12V, MIDI IN/OUT, SUSTAIN

Amplifier

- 6 W + 6 W (When using PA-5C power adaptor)
- 4 W + 4 W (When using batteries)

Speakers

- 12 cm x 2 + 3 cm x 2

Power Supply

- Adaptor : Yamaha PA-5C AC power adaptor
- Batteries : Six “D” size, R20P(LR20) or equivalent batteries

Power Consumption

- 20 W (when using PA-5C power adaptor)

Dimensions (W x D x H)

- 933 x 370 x 129 mm

Weight

- 6.2 kg

Supplied Accessories

- Music Stand
- Owner’s Manual
- Song Book

Optional Accessories

- Headphones : HPE-150
- AC power adaptor : PA-5C
- Footswitch : FC4, FC5
- Keyboard stand : L-2L, L-2C

* Specifications and descriptions in this owner’s manual are for information purposes only. Yamaha Corp. reserves the right to change or modify products or specifications at any time without prior notice. Since specifications, equipment or options may not be the same in every locale, please check with your Yamaha dealer.

Index

Misc.

+/- buttons..... 23

A

ABC/DoReMi 43

AC Power adaptor..... 8

accompaniment sections..... 62

Accompaniment Volume 61

Auto Accompaniment..... 51

auxiliary jacks..... 9

B

Bank 64

Batteries..... 8

Beat indicators 27

Bulk Dump 80

C

Chord Names..... 56

Chord Type..... 56

Chords, About..... 59

Chords, Fingered..... 56

Chords, Single Finger 55

D

DEMO button 28

Demo songs..... 28

Dictionary..... 58

Drum Kit List..... 91

DSP 49

DSP types 96

E

Effects 48

Ending 63

Expanded voices 42

F

Fill-in 62

Fingered chords 56

Flash Clear..... 74

Flash memory 71

Flash songs 71

Footswitch 9

G

GM System Level 1 76

Grade 37

H

Harmony 50

Harmony types 97

Headphones 9

I

Initial Send 81

Initialization 84

Intro 62

L

Lesson 34

Light Guide 32

Local Control..... 79

M

Main A/B 62

Metronome..... 39

MIDI..... 75

MIDI channels..... 75

MIDI Implementation Chart.98

MIDI LSB Receive cancel 77

MIDI terminals 77

Multi Fingered..... 55

Music Stand..... 9

N

numeric keypad..... 25

O

Octave 73

One Touch Setting..... 43

Overall buttons..... 23

P

PHONES/OUTPUT jack 9

Portable Grand..... 39

Q

Quick Guide 12

R

RECORD button 66

recording, song..... 66

Registration Memory 64

Reverb..... 48

Reverb types..... 96

Root 59

S

sections (accompaniment)... 62

Single Finger chords..... 55

Song Clear 69

Song Filer..... 71

SONG MEMORY 66

song recording..... 66

Song Volume 32

songs, recording..... 66

songs, selecting and playing 28

Specifications..... 102

Split Point 44

styles, selecting..... 51

SUSTAIN 9

Sync Start..... 52

Sync Stop..... 52

T

Talking..... 38

Tap 31

Tempo (song) 31

Tempo (style) 54

Time Signature..... 40

TOUCH button 47

Touch Sensitivity..... 47

track (song) 66

Track Clear 70

tracks, muting 29

Transpose 45

Troubleshooting..... 83

Tuning 46

U

User songs 66

V

Voice List..... 85

voices, selecting and playing 42

Limited Warranty

90 DAYS LABOR

1 YEAR PARTS

Yamaha Corporation of America, hereafter referred to as Yamaha, warrants to the original consumer of a product included in the categories listed below, that the product will be free of defects in materials and/or workmanship for the periods indicated. This warranty is applicable to all models included in the following series of products:

PSR SERIES OF PORTATONE ELECTRONIC KEYBOARDS

If during the first 90 days that immediately follows the purchase date, your new Yamaha product covered by this warranty is found to have a defect in material and/or workmanship, Yamaha and/or its authorized representative will repair such defect without charge for parts or labor.

If parts should be required after this 90 day period but within the one year period that immediately follows the purchase date, Yamaha will, subject to the terms of this warranty, supply these parts without charge. However, charges for labor, and/or any miscellaneous expenses incurred are the consumers responsibility. Yamaha reserves the right to utilize reconditioned parts in repairing these products and/or to use reconditioned units as warranty replacements.

THIS WARRANTY IS THE ONLY EXPRESS WARRANTY WHICH YAMAHA MAKES IN CONNECTION WITH THESE PRODUCTS. ANY IMPLIED WARRANTY APPLICABLE TO THE PRODUCT, INCLUDING THE WARRANTY OF MERCHANT ABILITY IS LIMITED TO THE DURATION OF THE EXPRESS WARRANTY. YAMAHA EXCLUDES AND SHALL NOT BE LIABLE IN ANY EVENT FOR INCIDENTAL OR CONSEQUENTIAL DAMAGES.

Some states do not allow limitations that relate to implied warranties and/or the exclusion of incidental or consequential damages. Therefore, these limitations and exclusions may not apply to you.

This warranty gives you specific legal rights. You may also have other rights which vary from state to state.

CONSUMERS RESPONSIBILITIES

If warranty service should be required, it is necessary that the consumer assume certain responsibilities:

1. Contact the Customer Service Department of the retailer selling the product, or any retail outlet authorized by Yamaha to sell the product for assistance. You may also contact Yamaha directly at the address provided below.
2. Deliver the unit to be serviced under warranty to: the retailer selling the product, an authorized service center, or to Yamaha with an explanation of the problem. Please be prepared to provide proof purchase date (sales receipt, credit card copy, etc.) when requesting service and/or parts under warranty.
3. Shipping and/or insurance costs are the consumers responsibility.* Units shipped for service should be packed securely.

*Repaired units will be returned PREPAID if warranty service is required within the first 90 days.

IMPORTANT: Do NOT ship anything to ANY location without prior authorization. A Return Authorization (RA) will be issued that has a tracking number assigned that will expedite the servicing of your unit and provide a tracking system if needed.

4. Your owners manual contains important safety and operating instructions. It is your responsibility to be aware of the contents of this manual and to follow all safety precautions.

EXCLUSIONS

This warranty does not apply to units whose trade name, trademark, and/or ID numbers have been altered, defaced, exchanged removed, or to failures and/or damages that may occur as a result of:

1. Neglect, abuse, abnormal strain, modification or exposure to extremes in temperature or humidity.
2. Improper repair or maintenance by any person who is not a service representative of a retail outlet authorized by Yamaha to sell the product, an authorized service center, or an authorized service representative of Yamaha.
3. This warranty is applicable only to units sold by retailers authorized by Yamaha to sell these products in the U.S.A., the District of Columbia, and Puerto Rico. This warranty is not applicable in other possessions or territories of the U.S.A. or in any other country.

Please record the model and serial number of the product you have purchased in the spaces provided below.

Model _____ Serial # _____ Sales Slip

Purchased from _____

Date _____

(Retailer)

YAMAHA CORPORATION OF AMERICA
Electronic Service Division
6600 Orangethorpe Avenue
Buena Park, CA 90620

KEEP THIS DOCUMENT FOR YOUR RECORDS. DO NOT MAIL!

For details of products, please contact your nearest Yamaha or the authorized distributor listed below.

Pour plus de détails sur les produits, veuillez-vous adresser à Yamaha ou au distributeur le plus proche de vous figurant dans la liste suivante.

Die Einzelheiten zu Produkten sind bei Ihrer unten aufgeführten Niederlassung und bei Yamaha Vertragshändlern in den jeweiligen Bestimmungsländern erhältlich.

Para detalles sobre productos, contacte su tienda Yamaha más cercana o el distribuidor autorizado que se lista debajo.

NORTH AMERICA

CANADA

Yamaha Canada Music Ltd.
135 Milner Avenue, Scarborough, Ontario,
M1S 3R1, Canada
Tel: 416-298-1311

U.S.A.

Yamaha Corporation of America
6600 Orangethorpe Ave., Buena Park, Calif. 90620,
U.S.A.
Tel: 714-522-9011

CENTRAL & SOUTH AMERICA

MEXICO

**Yamaha de Mexico S.A. De C.V.,
Departamento de ventas**
Javier Rojo Gomez No.1149, Col. Gpe Del
Moral, Deleg. Iztapalapa, 09300 Mexico, D.F.
Tel: 686-00-33

BRAZIL

Yamaha Musical do Brasil LTDA.
Av. Rebouças 2636, São Paulo, Brasil
Tel: 011-853-1377

ARGENTINA

Yamaha Music Argentina S.A.
Viamonte 1145 Piso2-B 1053,
Buenos Aires, Argentina
Tel: 1-4371-7021

PANAMA AND OTHER LATIN AMERICAN COUNTRIES/ CARIBBEAN COUNTRIES

Yamaha de Panama S.A.
Torre Banco General, Piso 7, Urbanización Marbella,
Calle 47 y Aquilino de la Guardia,
Ciudad de Panamá, Panamá
Tel: 507-269-5311

EUROPE

THE UNITED KINGDOM

Yamaha-Kemble Music (U.K.) Ltd.
Sherbourne Drive, Tilbrook, Milton Keynes,
MK7 8BL, England
Tel: 01908-366700

IRELAND

Danfay Ltd.
61D, Sallynoggin Road, Dun Laoghaire, Co. Dublin
Tel: 01-2859177

GERMANY/SWITZERLAND

Yamaha Europa GmbH.
Siemensstraße 22-34, 25462 Rellingen,
F.R. of Germany
Tel: 04101-3030

AUSTRIA

Yamaha Music Austria
Schleiergasse 20, A-1100 Wien Austria
Tel: 01-60203900

THE NETHERLANDS

Yamaha Music Nederland
Kanaalweg 18G, 3526KL, Utrecht, The Netherlands
Tel: 030-2828411

BELGIUM

Yamaha Music Belgium
Keiberg Imperiastraat 8, 1930 Zaventem, Belgium
Tel: 02-7258220

FRANCE

**Yamaha Musique France,
Division Claviers**
BP 70-77312 Marne-la-Vallée Cedex 2, France
Tel: 01-64-61-4000

ITALY

**Yamaha Musica Italia S.P.A.,
Home Keyboard Division**
Viale Italia 88, 20020 Lainate (Milano), Italy
Tel: 02-935-771

SPAIN/PORTUGAL

Yamaha-Hazen Electronica Musical, S.A.
Ctra. de la Coruna km. 17, 200, 28230
Las Rozas (Madrid) Spain
Tel: 91-120-0700

GREECE

Philippe Nakas S.A.
Navarinou Street 13, P.Code 10680, Athens, Greece
Tel: 01-364-7111

SWEDEN

Yamaha Scandinavia AB
J. A. Wettergrens Gata 1
Box 30053
S-400 43 Göteborg, Sweden
Tel: 031 89 34 00

DENMARK

YS Copenhagen Liaison Office
Generatorvej 8B
DK-2730 Herlev, Denmark
Tel: 44 92 49 00

FINLAND

F-Musiikki Oy
Kluuvikatu 6, P.O. Box 260,
SF-00101 Helsinki, Finland
Tel: 09 618511

NORWAY

Norsk filial av Yamaha Scandinavia AB
Grini Næringspark 1
N-1345 Østerås, Norway
Tel: 67 16 77 70

ICELAND

Skifan HF
Skeifan 17 P.O. Box 8120
IS-128 Reykjavik, Iceland
Tel: 525 5000

OTHER EUROPEAN COUNTRIES

Yamaha Europa GmbH.
Siemensstraße 22-34, 25462 Rellingen,
F.R. of Germany
Tel: 04101-3030

AFRICA

**Yamaha Corporation,
Asia-Pacific Music Marketing Group**
Nakazawa-cho 10-1, Hamamatsu, Japan 430-8650
Tel: 053-460-2312

MIDDLE EAST

TURKEY/CYPRUS

Yamaha Europa GmbH.
Siemensstraße 22-34, 25462 Rellingen,
F.R. of Germany
Tel: 04101-3030

OTHER COUNTRIES

Yamaha Music Gulf FZE
LB21-128 Jebel Ali Freezone
P.O.Box 17328, Dubai, U.A.E.
Tel: 971-4-881-5868

ASIA

HONG KONG

Tom Lee Music Co., Ltd.
11/F, Silvercord Tower 1, 30 Canton Road,
Tsimshatsui, Kowloon, Hong Kong
Tel: 2737-7688

INDONESIA

**PT. Yamaha Music Indonesia (Distributor)
PT. Nusantik**
Gedung Yamaha Music Center, Jalan Jend. Gatot
Subroto Kav. 4, Jakarta 12930, Indonesia
Tel: 21-520-2577

KOREA

Cosmos Corporation
1461-9, Seocho Dong, Seocho Gu, Seoul, Korea
Tel: 02-3486-0011

MALAYSIA

Yamaha Music Malaysia, Sdn., Bhd.
Lot 8, Jalan Perbandaran, 47301 Kelana Jaya,
Petaling Jaya, Selangor, Malaysia
Tel: 3-703-0900

PHILIPPINES

Yupangco Music Corporation
339 Gil J. Puyat Avenue, P.O. Box 885 MCPO,
Makati, Metro Manila, Philippines
Tel: 819-7551

SINGAPORE

Yamaha Music Asia Pte., Ltd.
11 Ubi Road #06-00, Meiban Industrial Building,
Singapore
Tel: 65-747-4374

TAIWAN

Yamaha KHS Music Co., Ltd.
10F, 150, Tun-Hwa Northroad,
Taipei, Taiwan, R.O.C.
Tel: 02-2713-8999

THAILAND

Siam Music Yamaha Co., Ltd.
121/60-61 RS Tower 17th Floor,
Ratchadaphisek RD., Dindaeng,
Bangkok 10320, Thailand
Tel: 02-641-2951

THE PEOPLE'S REPUBLIC OF CHINA AND OTHER ASIAN COUNTRIES

**Yamaha Corporation,
Asia-Pacific Music Marketing Group**
Nakazawa-cho 10-1, Hamamatsu, Japan 430-8650
Tel: 053-460-2317

OCEANIA

AUSTRALIA

Yamaha Music Australia Pty. Ltd.
Level 1, 99 Queensbridge Street, Southbank, Victoria
3006, Australia
Tel: 3-9693-5111

NEW ZEALAND

Music Houses of N.Z. Ltd.
146/148 Captain Springs Road, Te Papapa,
Auckland, New Zealand
Tel: 9-634-0099

COUNTRIES AND TRUST TERRITORIES IN PACIFIC OCEAN

**Yamaha Corporation,
Asia-Pacific Music Marketing Group**
Nakazawa-cho 10-1, Hamamatsu, Japan 430-8650
Tel: 053-460-2312

HEAD OFFICE Yamaha Corporation, Pro Audio & Digital Musical Instrument Division
Nakazawa-cho 10-1, Hamamatsu, Japan 430-8650
Tel: 053-460-3273



Yamaha Manual Library (English versions only)
<http://www2.yamaha.co.jp/manual/english/>

M.D.G., PA·DMI Division, Yamaha Corporation
© 2001 Yamaha Corporation

V***** ***AP*** *-01A0 Printed in China