

# MCR-840

(R-840 + DVD-840 + NS-BP300)

*RECEIVER/DVD PLAYER*



# CAUTION: READ THIS BEFORE OPERATING YOUR UNIT.

- 1 To assure the finest performance, please read this manual carefully. Keep it in a safe place for future reference.
- 2 Install this sound system in a well ventilated, cool, dry, clean place and away from direct sunlight, heat sources, vibration, dust, moisture and cold. For proper ventilation, allow the following minimum clearances.  
Top: 30 cm (R-840 Only)  
Rear: 10 cm  
Sides: 10 cm
- 3 Locate this unit away from other electrical appliances, motors, or transformers to avoid humming sounds.
- 4 Do not expose this unit to sudden temperature changes from cold to hot, and do not locate this unit in an environment with high humidity (i.e. a room with a humidifier) to prevent condensation inside this unit, which may cause an electrical shock, fire, damage to this unit, and/or personal injury.
- 5 Avoid installing this unit where foreign object may fall onto this unit and/or this unit may be exposed to liquid dripping or splashing. On the top of this unit, do not place:
  - Other components, as they may cause damage and/or discoloration on the surface of this unit.
  - Burning objects (i.e. candles), as they may cause fire, damage to this unit, and/or personal injury.
  - Containers with liquid in them, as they may fall and liquid may cause electrical shock to the user and/or damage to this unit.
- 6 Do not cover this unit with a newspaper, tablecloth, curtain, etc. in order not to obstruct heat radiation. If the temperature inside this unit rises, it may cause fire, damage to this unit, and/or personal injury.
- 7 Do not plug in this unit to a wall outlet until all connections are complete.
- 8 Do not operate this unit upside-down. It may overheat, possibly causing damage.
- 9 Do not use force on switches, knobs and/or cords.
- 10 When disconnecting the power cable from the wall outlet, grasp the plug; do not pull the cable.
- 11 Do not clean this unit with chemical solvents; this might damage the finish. Use a clean, dry cloth.
- 12 Only voltage specified on this unit must be used. Using this unit with a higher voltage than specified is dangerous and may cause fire, damage to this unit, and/or personal injury. Yamaha will not be held responsible for any damage resulting from use of this unit with a voltage other than specified.
- 13 To prevent damage by lightning, keep the power cable and outdoor antennas disconnected from a wall outlet or this unit during a lightning storm.
- 14 Do not attempt to modify or fix this unit. Contact qualified Yamaha service personnel when any service is needed. The cabinet should never be opened for any reasons.
- 15 When not planning to use this unit for long periods of time (i.e. vacation), disconnect the AC power plug from the wall outlet.
- 16 Be sure to read the “TROUBLESHOOTING” section on common operating errors before concluding that this unit is faulty.
- 17 Before moving this unit, press  $\odot$  to set it to standby mode and disconnect the AC power plug from the wall outlet.

- 18 Condensation will form when the surrounding temperature changes suddenly. Disconnect the power cable from the outlet, then leave this unit alone.
- 19 When using this unit for a long time, this unit may become warm. Turn the power off, then leave this unit alone for cooling.
- 20 Install this unit near the AC outlet and where the AC power plug can be reached easily.
- 21 The batteries shall not be exposed to excessive heat such as sunshine, fire or the like.
- 22 Excessive sound pressure from earphones and headphones can cause hearing loss.

This unit is not disconnected from the AC power source as long as it is connected to the wall outlet, even if this unit itself is turned off by  $\odot$ . This state is called standby mode. In this state, this unit is designed to consume a very small quantity of power.

## LASER SAFETY

This unit employs a laser. Due to possible eye injury, only a qualified service person should remove the cover or attempt to service this device.

## DANGER

This unit emits visible laser radiation when open. Avoid direct eye exposure to beam. When this unit is plugged into the wall outlet, do not place your eyes close to the opening of the disc tray and other openings to look into inside.

The laser component in this product is capable of emitting radiation exceeding the limit for Class 1.

## LASER

Type	Semiconductor laser AlGaInP
Wave length	655 nm (DVD) 790 nm (VCD/CD)
Output Power	5 mW (DVD) 7 mW (VCD/CD)
Beam divergence	20 degree

## WARNING

TO REDUCE THE RISK OF FIRE OR ELECTRIC SHOCK, DO NOT EXPOSE THIS UNIT TO RAIN OR MOISTURE.

# CONTENTS

## INTRODUCTION

<b>FEATURES</b> .....	2
<b>SUPPLIED ACCESSORIES</b> .....	2
<b>NOTES ABOUT PLAYABLE DISCS/FILES</b> .....	3
<b>CONTROLS AND FUNCTIONS</b> .....	4
Receiver (R-840).....	4
DVD player (DVD-840) .....	5
Remote control.....	6

## PREPARATION

<b>PREPARATIONS</b> .....	8
Connecting speakers/external components/ antennas .....	8
Connecting power cables .....	9
Connecting a recorder (CDR, MDR, etc.) .....	10
Connecting an AV receiver or decoder .....	10
Connecting an iPod™ .....	11
Connecting USB devices .....	11
Installing the batteries in the remote control .....	12
Using the remote control .....	12
Adjusting the Clock .....	13
<b>SETTING THE SYSTEM</b> .....	14
Turn on the TV and the system .....	14
Setting the TV display .....	14
Selecting the output type for COMPONENT jacks .....	15
Selecting the HDMI audio output .....	15
On-screen display (OSD) language .....	15
Audio, Subtitle and Disc menu languages .....	16

## BASIC OPERATIONS

<b>SYSTEM OPERATIONS</b> .....	17
Basic system operations.....	17
Changing the brightness of the front panel display .....	18
To use headphones .....	18
<b>DISC AND USB DEVICE OPERATIONS</b> .....	19
Using the on-screen display .....	19
Playback operations .....	19
Stopping playback .....	20
Resume and Last Memory .....	20
Pausing playback .....	20
Rewind and fast forward.....	20
Selecting chapters and tracks .....	21
Selecting items by number.....	21
DVD-Video menus .....	21
VCD and SVCD menus (PBC).....	21
Slow-motion playback .....	22
Frame-by-frame playback .....	22
Selecting languages and audio.....	22
Selecting subtitles .....	22
Selecting camera angles.....	23
Zoom.....	23
Repeat playback.....	23
A-B repeat playback.....	24
Random playback .....	24
Program playback .....	25
Searching Discs .....	25
Playing JPEG slideshows.....	26
Using Disc Navigator with DVD-Video, VCD, and SVCD discs.....	26

Using Disc Navigator with MP3, WMA, MPEG-4 AAC, DivX®, WMV, and JPEG discs/USB devices .....	27
Viewing disc information.....	28
Viewing the audio format .....	28

## TUNER OPERATIONS

### DAB (DIGITAL AUDIO BROADCASTING)

<b>TUNING</b> .....	29
Preparing the DAB tuning .....	29
Tuning DAB stations .....	29
DAB station information .....	30
Presetting DAB stations.....	30
Selecting preset DAB stations (Preset tuning).....	30
Using DAB option menu .....	31
DAB frequency information .....	32
<b>FM TUNING</b> .....	33
Automatic tuning .....	33
Manual tuning.....	33
Automatic preset tuning.....	33
Manual preset tuning .....	34
Selecting preset stations.....	34

## OTHER OPERATIONS

<b>SETTING THE TIMER</b> .....	35
Setting the clock timer .....	35
Setting the sleep timer .....	36
<b>SETTING THE AUTO-STANDBY MODE</b> .....	37
<b>CONTROLLING iPod™</b> .....	38
Using iPod™ .....	38
<b>DVD SETUP MENU OPTIONS</b> .....	39
Audio Settings menu .....	39
Video Adjust menu .....	39
Initial Settings menu .....	40

## ADDITIONAL INFORMATION

<b>TROUBLESHOOTING</b> .....	45
Receiver (R-840).....	45
Remote control .....	47
DVD player (DVD-840) .....	47
<b>SUPPORTED DISCS AND FORMATS</b> .....	49
Copy Control CDs .....	49
DualDisc .....	49
Recordable disc compatibility .....	49
Discs made on a computer .....	49
MP3, WMA, and MPEG-4 AAC files .....	49
JPEG files .....	50
About DivX® .....	50
About WMV .....	50
About MPEG-4 AAC.....	51
About WMA .....	51
DVD-Video regions .....	51
<b>NOTES ABOUT HANDLING DISCS</b> .....	52
<b>GLOSSARY</b> .....	53
<b>SPECIFICATIONS</b> .....	55
Resetting the DVD player.....	56
<b>LANGUAGE, COUNTRY, AND REGION</b>	
<b>LISTS</b> .....	57
Language list.....	57
Country and region list .....	57

INTRODUCTION

PREPARATION

BASIC  
OPERATIONS

TUNER  
OPERATIONS

OTHER  
OPERATIONS

ADDITIONAL  
INFORMATION

English

# FEATURES

## Receiver (R-840)

- Minimum RMS output power per channel 65W + 65W (6Ω, 1kHz, 10% THD)
- 30-station DAB preset tuning
- 30-station FM preset tuning
- iPod playability (with rechargeable function)
- Pure Direct mode
- Adjustable display brightness

## DVD player (DVD-840)

- Plays DVDs, Super Video CDs/Video CDs, Audio CDs, MP3/WMA/MPEG-4 AAC discs, WMV discs, DivX discs and JPEG discs
- Plays MP3/WMA/MPEG-4 AAC and JPEG files stored on a USB device
- Linked operation with the receiver such as Pure Direct mode, adjustable display brightness and INPUT mode

## ■ About this manual

- In this manual, “R-840” is described as “receiver” and “DVD-840” is described as “DVD player”.
- This manual describes how to operate the system using a remote control except when it is not available. Some of these operations are also available using the front panel buttons.
-  indicates a tip for your operation.
- Notes contain important information about safety and operating instructions.
- This manual is printed prior to production. Design and specifications are subject to change in part as a result of improvements, etc. In case of differences between the manual and the product, the product has priority.

# SUPPLIED ACCESSORIES

This product includes the following accessories. Before connecting this system, make sure you received all of the following parts.

Remote control

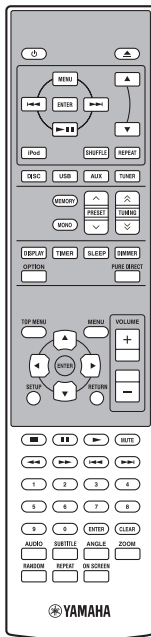

Batteries (x2)  
(AAA, R03, UM-4)

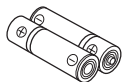

Indoor FM antenna

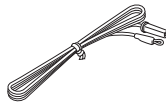

Indoor DAB antenna



System control cable (0.6 m)



Composite video cable (1.5 m)

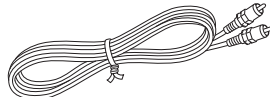

RCA stereo cable (1.0 m)

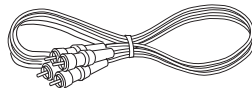

USB cap\*



DVD player

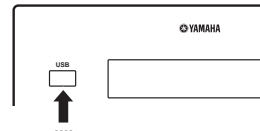

### CAUTION

Keep the USB cap out of the reach of children, so that it is not mistakenly swallowed.

iPod dock cover\*

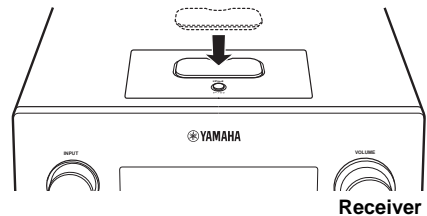

\* The USB cap and the iPod dock cover are supplied with this product to cover the USB port and the iPod dock when not in use.

# NOTES ABOUT PLAYABLE DISCS/FILES

## ■ Playable discs

The DVD player is designed for use with the following discs.

- DVD disc: DVD-Video, DVD-R/-RW/-R DL, DVD+R/+RW/+R DL
- Compact Disc: Audio CD, CD-R, CD-RW, Video CD (VCD), Super Video CD (SVCD)



### Notes

- DVD-R/-RW/-R DL and DVD+R/+RW/+R DL discs recorded in DVD-Video compatible format.
- DVD-R/-RW/-R DL discs recorded in VR format (compatible with CPRM).
- CD-R/RW, DVD-R/-RW/-R DL and DVD+R/+RW/+R DL cannot be played unless finalized.
- Multi-session discs are not supported.
- Some discs recorded on PC cannot be played depending on the settings of the application software.
- Discs recorded on a PC by packet writing cannot be played on this DVD player.
- This unit is not compatible with 8-cm discs.

## ■ Playable files

The DVD player can play the following formatted files recorded on CD-R/RW, DVD-R/-RW, DVD+R/+RW and USB devices.

### Compressed audio file

- MPEG1 audio layer3 (MP3)
- Windows Media Audio (WMA)
- MPEG-4 AAC

### Still image file

- JPEG
- FUJICOLOR CD
- KODAK Picture CD

### Movie file

(except files saved on USB devices)

- WMV
- DivX® Ultra
  - Official DivX® Ultra Certified product.
  - Plays all versions of DivX® video (including DivX® 6) with enhanced playback of DivX® media files and the DivX® Media Format.



Refer to “DISC AND USB DEVICE OPERATIONS” (p.19) for details.

## ■ Region codes

The DVD player is designed to support the Region Management System. Check the region code number on the disc package. If the number does not match the unit’s region number (Refer to the table below or the back of the unit), the unit may be unable to play the disc.

Destination	Region code of DVD-840	Playable discs
U.S.A., and Canada model		
Europe model		
Asia and Taiwan models		
Australia model		
Russia model		
China model		

## ■ To play back an 8-cm (3-inch) CD

Place it in the inner recessed area of the disc tray. Do not put a normal (12-cm) CD on top of an 8-cm (3-inch) CD.

**Note:** Do not use any lens cleaners as they may be a cause of malfunction.

# CONTROLS AND FUNCTIONS

## Receiver (R-840)

### ■ Front panel

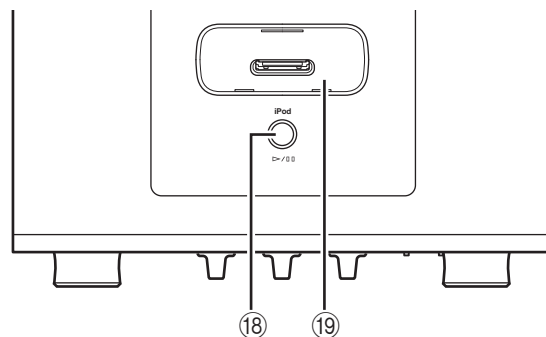
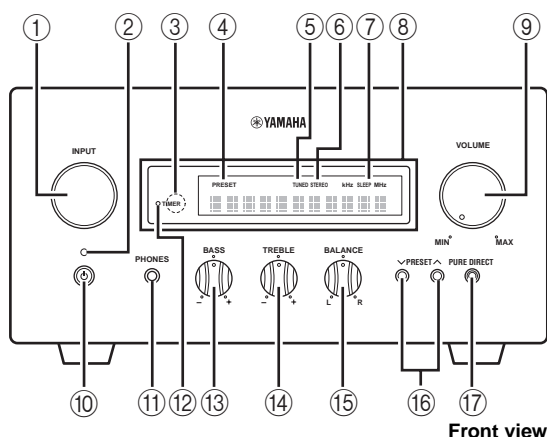

Top view

#### ① INPUT

Selects an input source.

#### ② On/Standby indicator

Lights up in green when the receiver is turned on. Lights up in amber when the receiver is in standby mode.

#### ③ Remote control sensor

Receives signals from the remote control.

#### ④ PRESET indicator

Lights up when you select preset radio stations (see p.30, p.34).

#### ⑤ TUNED indicator

Lights up when the receiver is tuned into a station.

#### ⑥ STEREO indicator

Lights up when the receiver is receiving a strong signal from a DAB/FM stereo broadcast.

#### ⑦ SLEEP indicator

Lights up when the sleep timer is on (see p.36).

#### ⑧ Front panel display

Shows the various information such as the tuning frequency.

#### ⑨ VOLUME

Adjusts the volume level.

#### ⑩ ⏻ (On/Standby)

Turns the receiver on or sets it to standby mode.

#### ⑪ PHONES jack

Outputs audio signals for private listening with headphones.

#### ⑫ TIMER indicator

Lights up when the timer is set (see p.35).

#### ⑬ BASS

Adjusts the low frequency response (see p.17).

#### ⑭ TREBLE

Adjusts the high frequency response (see p.17).

#### ⑮ BALANCE

Adjusts the audio output balance of the left to right speakers to compensate for imbalances caused by speaker locations or listening room conditions.

#### ⑯ PRESET ∨ / ∧

Selects a preset station. The input source is changed to either DAB or FM, whichever was last selected. Operable even when the receiver is in standby mode (see p.30, p.34).

#### ⑰ PURE DIRECT

Turns on or off Pure Direct mode (see p.17).

When Pure Direct mode is on, the indicator lights up in blue.

#### ⑱ ▷ / ⏸

Starts and pauses the playback of iPod. The input source is changed to iPod. Operable even when the receiver is in standby mode.

#### ⑲ iPod dock

Connect your iPod (see p.11).

## DVD player (DVD-840)

### ■ Front panel

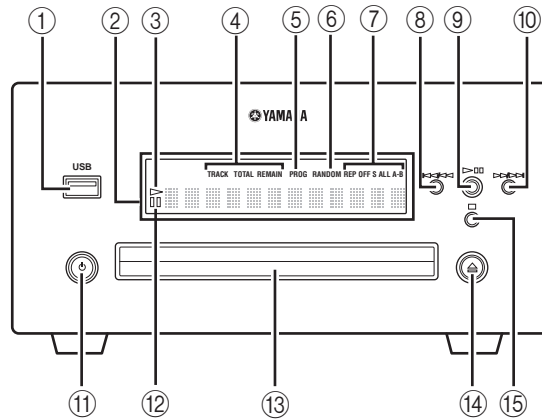

#### ① USB port

Connect your USB device.

#### ② Front panel display

Shows the current status of the DVD player.

#### ③ ▷ (play) indicator

Appears during playback.

#### ④ Time display mode indicator

Indicate the kind of time information displayed on the front panel display (☞p.28).

#### ⑤ PROG indicator

Lights up when Program play mode is selected.

#### ⑥ RANDOM indicator

Lights up when Random play mode is selected.

#### ⑦ REP OFF S ALL A-B indicator

Lights up when Repeat play mode is selected.

#### ⑧ ⏮/⏪

Returns to the beginning of the current chapter or track. Press and hold to fast reverse. Press twice to skip to the previous chapter or track (☞p.20).

#### ⑨ ▷/⏸

Starts or pauses playback (☞p.19).

When this button is pressed during standby mode, the receiver automatically turns on and the input source changes to either DISC or USB, whichever was last selected.

#### ⑩ ▷▷/⏩

Skips to the next chapter or track. Press and hold to fast forward (☞p.20).

#### ⑪ ⏻ (On/Standby)

Turns on the DVD player or sets it to standby mode.

When this button is pressed during standby mode, the receiver automatically turns on and the input source changes to either DISC or USB, whichever was selected last.

#### ⑫ ⏸ (pause) indicator

Lights up while the DVD player is paused.

#### ⑬ Disc tray

Holds a disc to be played back.

#### ⑭ ⏴

Opens and closes the disc tray.

When this button is pressed during standby mode, the receiver automatically turns on and the input source changes to DISC.

#### ⑮ ⏹

Stops playback (☞p.20).

## Remote control

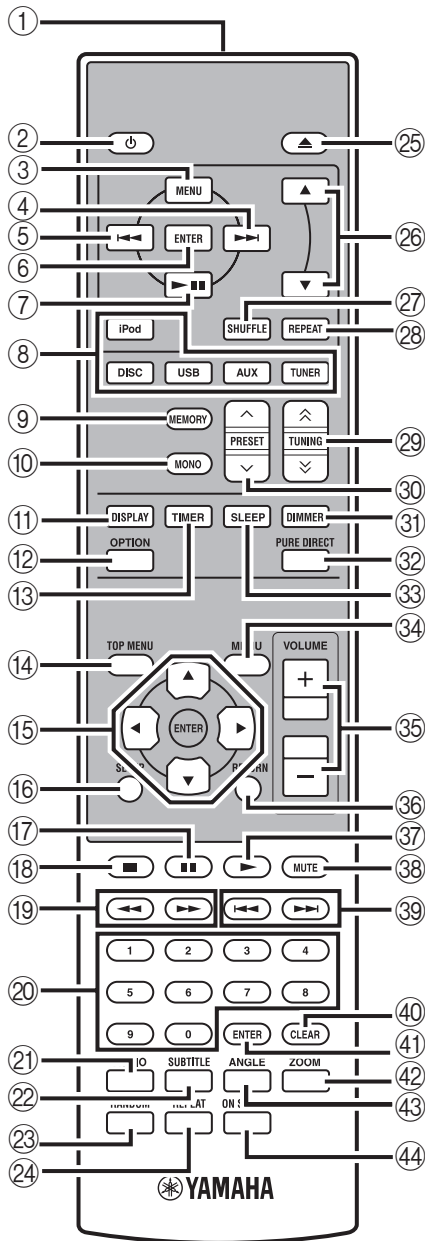

This remote control can operate the system components (including tuner functions) and an iPod stationed in the iPod dock on the top of the receiver. To operate the DVD player, tuner functions, or an iPod using the remote control, you need to set the receiver to corresponding input mode (see ⑧ Input selection keys).

### To operate your iPod

Press the corresponding iPod operation key on the remote control.

The iPod operation keys are indicated with **iPod** in the section below. See page 38 for more information on the operation of your iPod.

#### ① Infrared signal transmitter

Sends signals to the system you want to control.

#### ② **⏻ (On/Standby)**

Turns the system on or sets it to standby mode.

#### ③ **MENU iPod**

Returns to the upper level in the iPod menu.

#### ④ **▶▶ iPod**

Skips to the next song. Press and hold to fast forward.

#### ⑤ **◀◀ iPod**

Skips to the beginning of the current track. Press twice to skip back to the previous track. Press and hold to fast reverse.

#### ⑥ **ENTER iPod**

Press ENTER to enter the selected group. (Pressing ENTER starts playback when a song is selected.)

#### ⑦ **▶/|| iPod**

Starts or Pauses Playback.

#### ⑧ **Input selection keys**

Selects the input source on the receiver.

When selecting an input source, press the corresponding input selection key (or turn INPUT on the front panel). The name of the corresponding input source appears on the front panel display of the receiver. Each time you press TUNER, the input switches between DAB and FM.



When DISC or USB is selected as an input source, the DVD player turns on automatically and when other input source is selected, the DVD player sets to standby mode.

#### ⑨ **MEMORY**

Stores a preset station in the memory (see p.30, p.34). Starts Automatic preset tuning (see p.33).

#### ⑩ **MONO**

Sets FM broadcasting receiving mode to monaural mode.



**① DISPLAY**

Switches the information shown on the front panel display of the receiver and DVD player (☞p.28, p.30).

**② OPTION**

Enters option menu mode.

See pages 31, 34 and 37 for option menu items.

**③ TIMER**

Shows the current time on the front panel display of the receiver.

And sets the clock (☞p.13) or the timer (☞p.35).

**④ TOP MENU**

Displays the DVD's top menu (☞p.21).

**⑤ ▲, ▼, ◀, ▶, ENTER**

For selecting and confirming an item.

**⑥ SETUP**

Displays the Setup menu (☞p.14).

**⑦ ■■**

Pauses playback (☞p.20).

**⑧ ■**

Stops playback (☞p.20).

**⑨ ◀◀, ▶▶**

Rewind and fast-forward.

**⑩ Numeric keys**

Input numbers.

**⑪ AUDIO**

Selects the audio format and soundtrack (☞p.22).

**⑫ SUBTITLE**

Selects subtitles (☞p.22).

**⑬ RANDOM**

Turns on/off the Random Play mode (☞p.24).

**⑭ REPEAT**

Selects Repeat Play mode (☞p.23).

**⑮ ▲**

Opens and closes the disc tray.

**⑯ ▲, ▼ iPod**

Press ▲ or ▼ to switch an item in the selected group (☞p.38).

**⑰ SHUFFLE iPod**

Selects mode of Shuffle Play (☞p.38).

**⑱ REPEAT iPod**

Selects mode of Repeat Play (☞p.38).

**⑲ TUNING ↗/↘**

Press TUNING ↗/↘ to Manual tuning and press and hold TUNING ↗/↘ to Automatic tuning (☞p.29, p.33).

**⑳ PRESET ^/∨**

Select a preset station (☞p.30, p.34).

**㉑ DIMMER**

Changes the brightness of the front panel display (☞p.18).

**㉒ PURE DIRECT**

Turns on or off Pure Direct mode (☞p.17).

**㉓ SLEEP**

Sets the sleep timer on the system (☞p.36).

**㉔ MENU**

Displays the DVD's menu (☞p.21).

**㉕ VOLUME +/-**

Adjusts the overall volume level on the receiver.

**㉖ RETURN**

Returns to the previous menu (☞p.19).

**㉗ ▶**

Starts playback (☞p.19).

**㉘ MUTE**

Turn off the volume (☞p.18).

**㉙ ◀◀, ▶▶**

Skips to the beginning of the current or next chapter or track.

**㉚ CLEAR**

Clears an entry.

**㉛ ENTER**

Confirms an entry.

**㉜ ZOOM**

Zooms on-screen pictures (☞p.23).

**㉝ ANGLE**

Selects an camera angle (☞p.23).

**㉞ ON SCREEN**

Displays disc information on-screen (☞p.28).

# PREPARATIONS

## Connecting speakers/external components/antennas

Make sure you read the following procedure and note carefully before connecting the system. **The remote control and linked operation of the system only work when the receiver and the DVD player are connected via the system control cable.** For information on the speakers (NS-BP300), refer to the owner's manual supplied with it.

### Connecting the system

- 1 Connect the AUDIO IN (A) PLAYER L/R jacks of the receiver to the AUDIO OUT (A) L/R jacks of the DVD player using the supplied audio RCA stereo cable.
- 2 Connect the SYSTEM CONNECTOR (B) TO:PLAYER jack of the receiver to the SYSTEM CONNECTOR (B) TO:RECEIVER jack of the DVD player using the supplied system control cable.
- 3 Connect the speaker terminals (L) of the receiver to the speaker terminals of the left speaker and the speaker terminals (R) of the receiver to the speaker terminals of the right speaker using the speaker cables supplied with the speaker set (NS-BP300).
- 4 Connect the supplied FM antenna to the FM jack, and DAB antenna to the DAB jack.

#### Indoor DAB antenna (supplied)

Stretch out the antenna and place it to find the best reception position then fix it.

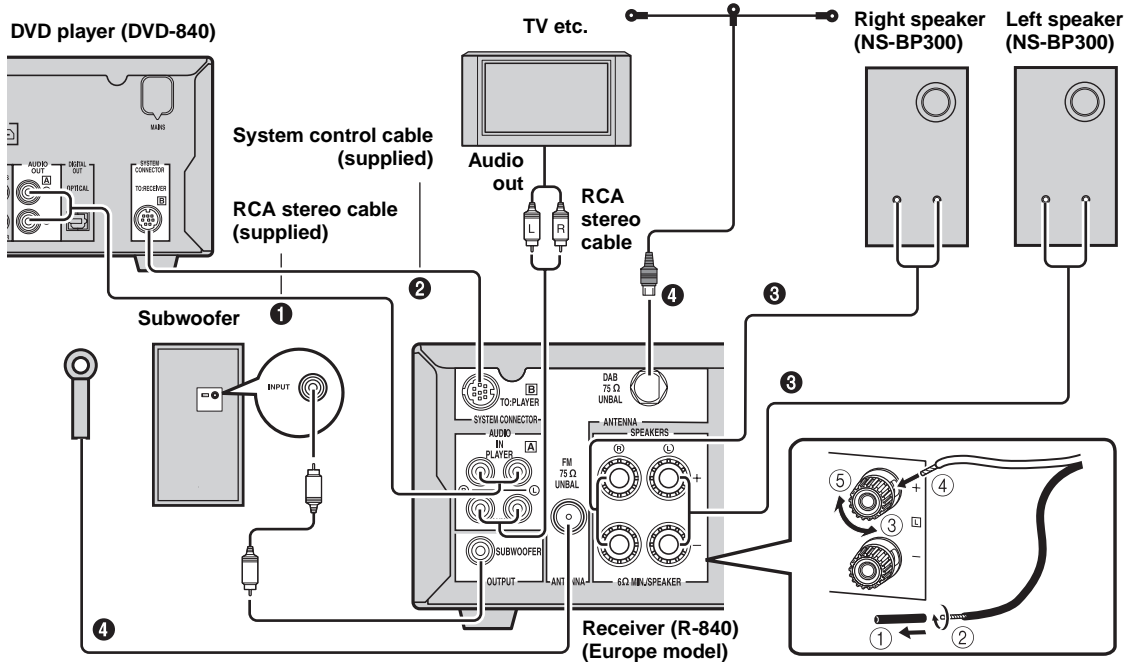

### CAUTION

- Do not connect this unit or other components to the main power until all connections between components are complete.
- Do not let the bare speaker wires touch each other or any metal part of the receiver. This could damage the receiver and/or the speakers.
- All connections must be correct: L (left) to L, R (right) to R, “+” to “+” and “-” to “-”. If the connections are faulty, no sound will be heard from the speakers, and if the polarity of the speaker connections is incorrect, the sound will be unnatural and lack bass. Also, refer to the owner's manual for each of your components.

### Notes

- The system control connection is used to transmit the remote control signals from the receiver to the DVD player.
- When connecting speakers other than NS-BP300, use speakers having more than 6Ω impedance.
- If there is a problem of weak radio wave reception in your area or you want to improve radio reception, we recommend that you use commercially available outdoor antennas. For details, consult the nearest authorized Yamaha dealer or service center.

### Connecting a TV to the system

- ① Connect the system and your TV via the HDMI jack, COMPONENT jacks or VIDEO jack of the DVD player and the corresponding jack(s) of your TV.
- ② Set “TV Screen” according to your TV (see “Setting the TV display” on page 14).

DVD player (DVD-840)

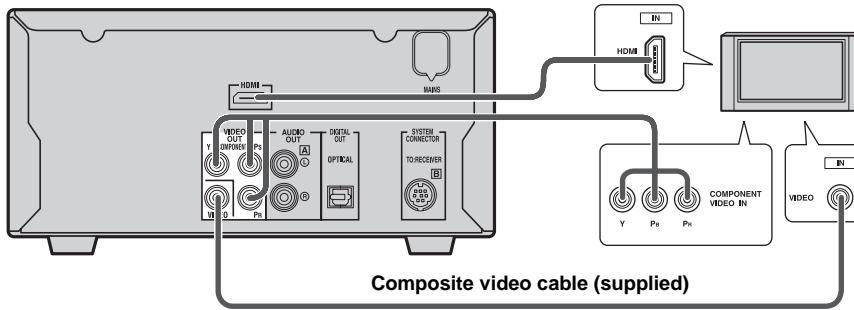

Composite video cable (supplied)

When connecting the system and your TV via the COMPONENT jacks, set the DVD player as described in “Selecting the output type for COMPONENT jacks” (p.15).

When connecting the system and your TV via the HDMI jacks, set “HDMI Resolution” and “HDMI Color” of “Video Output settings” in the Initial Settings menu (p.40).

### Connecting power cables

After you made all connections, connect the power cables of this system and other components to AC wall outlets.

Receiver (R-840)

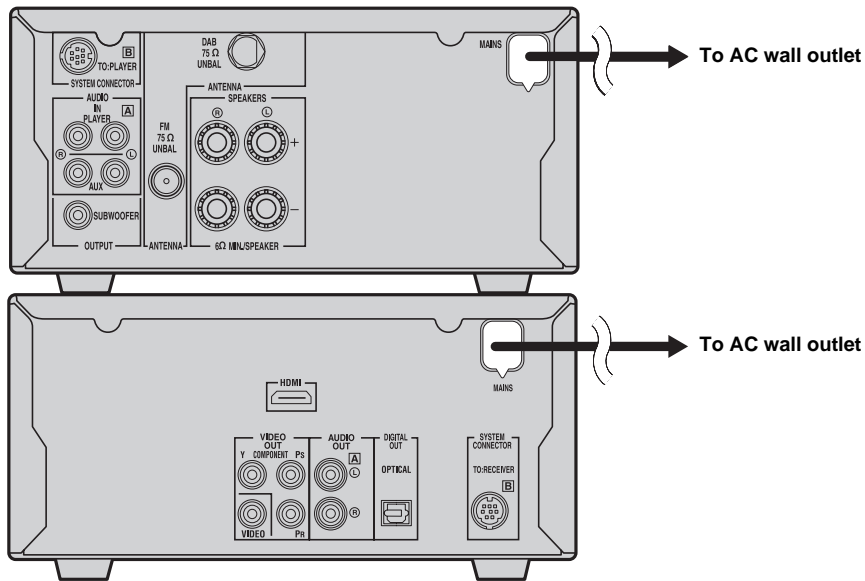

DVD player (DVD-840)

## Connecting a recorder (CDR, MDR, etc.)

You can connect a recording component, such as a CDR or MDR, to the DVD player for recording.

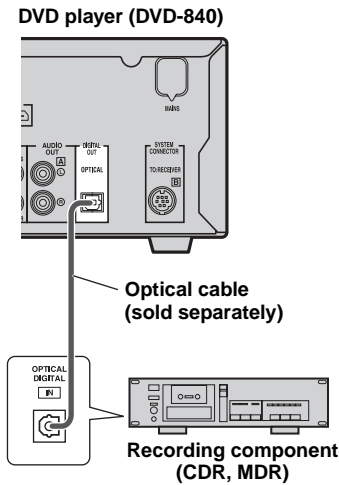

### Notes

- Do not connect the power cable to the DVD player until all other connections have been completed.
- Turn off the recording component before connecting it to the DVD player.
- The DIGITAL OUT outputs audio only when the input source is DISC or USB, and with some discs and files, recording may not be possible due to copy protection.

## Connecting an AV receiver or decoder

The DVD player downmixes multi-channel sources, such as Dolby Digital and DTS, into a 2-channel stereo mix that you can enjoy through the speakers connected to the DVD player. By connecting an AV receiver/decoder to the DVD player's DIGITAL OUT jack, you can enjoy Dolby Digital and DTS sources through the speakers connected to your AV receiver/decoder.

### Notes

- Make sure the digital audio output settings are configured so that the DIGITAL OUT outputs MPEG, Dolby Digital, and DTS material as it is and not as PCM.
- You may want to turn down the volume on the DVD player all the way when listening through the speakers connected to your AV receiver/decoder.
- The DIGITAL OUT outputs audio only when the input source is DISC or USB.

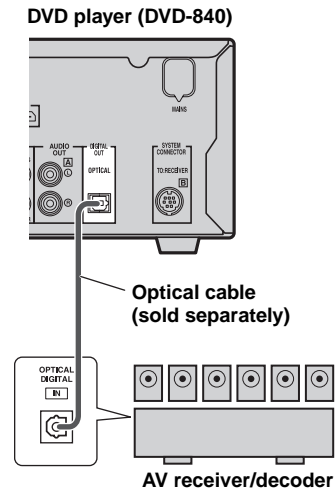

## Connecting an iPod™

The receiver is equipped with the iPod dock on the top panel where you can station your iPod and control playback of your iPod using the supplied remote control. Use this receiver with iPod dock adapter (supplied with your iPod or commercially available) appropriate for your iPod. If you use this receiver without using an appropriate iPod dock adapter, loose connection may result.



When the receiver is turned on or in standby mode, connect the iPod during the playback. The receiver automatically starts playback of iPod (for the fifth or later generation of iPod, iPod touch, iPod Classic, or iPod nano).

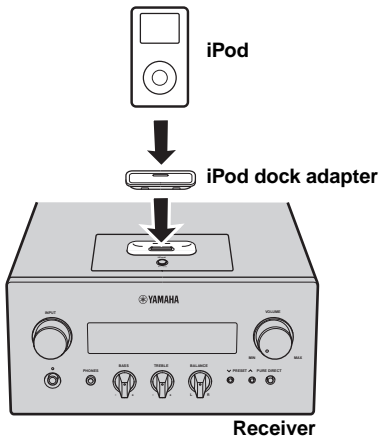

### Notes

- Only iPod (Click and Wheel), iPod nano, iPod Classic, iPod mini and iPod touch are supported.
- Do not connect any iPod accessories (such as headphones, a wired remote control, or an FM transmitter) to your iPod when it is stationed in the iPod dock.
- Unless your iPod is firmly stationed in the iPod dock, audio signals may not be output properly.
- Once the connection between your iPod and the receiver is complete and the receiver is set to iPod mode (p.6), “CONNECTED” appears on the front panel display. If the connection between your iPod and the receiver fails, a status message appears on the front panel display. For a complete list of connection status message, see the iPod section in “TROUBLESHOOTING” (p.45).
- When your iPod is stationed in the iPod dock of the receiver, your iPod can be charged automatically even when the receiver is in standby mode.
- You can disconnect the iPod during the playback.

## Connecting USB devices

This DVD player has a USB port and can access MP3, WMA, MPEG-4 AAC, or JPEG files saved on your USB device. Connect your USB device to the USB port on the front panel of the DVD player.

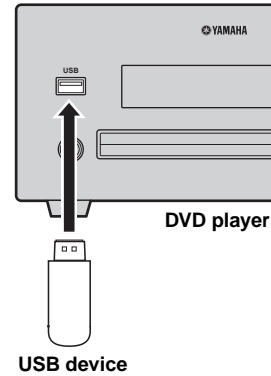

### Supported USB devices

This DVD player supports USB mass storage class devices (e.g., flash memories, card readers or portable audio players) using FAT16 or FAT32 format.

### Notes

- Some devices may not work properly even if they meet the requirements.
- Do not connect devices other than the USB mass storage class devices.
- When you insert two or more memory cards at the same time using card readers, etc., only one of the memory cards is recognized.
- Yamaha and suppliers accept no liability for the loss of data saved on the USB devices connected to the receiver. As a precaution, it is recommended that the files are made backup copies.
- Playability of and power supply to all kind of USB devices are not guaranteed.
- When your USB device is connected to the USB port, your USB device can be charged automatically even when the DVD player is in standby mode. Some USB devices cannot be charged in standby mode.
- You can disconnect the USB device during the playback.

## Installing the batteries in the remote control

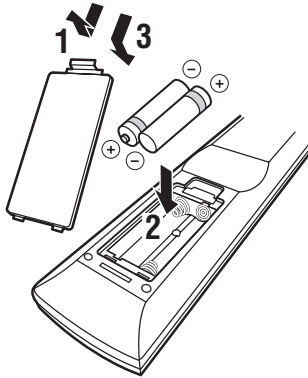

### Notes on batteries

- Change both batteries when the operation range of the remote control decreases.
- Use AAA, R03, UM-4 batteries.
- Make sure that the polarities are correct. See the illustration inside the battery compartment.
- Remove the batteries if the remote control is not to be used for an extended period of time.
- Do not use old batteries together with new ones.
- Do not use different types of batteries (such as alkaline and manganese batteries) together. Read the packaging carefully as these different types of batteries may have the same shape and color.
- If the batteries have leaked, dispose of them immediately. Avoid touching the leaked material or letting it come into contact with clothing, etc. Clean the battery compartment thoroughly before installing new batteries.
- Do not throw away batteries with general house waste; dispose of them correctly in accordance with your local regulations.

## Using the remote control

The remote control transmits a directional infrared beam. Be sure to aim the remote control directly at the remote control sensor on the front panel of the receiver during operation.

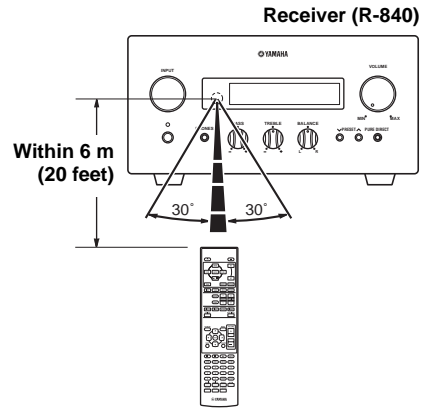

### Notes

- The area between the remote control and the receiver must be clear of large obstacles.
- Do not spill water or other liquids on the remote control.
- Do not drop the remote control.
- Do not leave or store the remote control in the following types of conditions:
  - high humidity, such as near a bath
  - high temperature, such as near a heater or a stove
  - extremely low temperatures
  - dusty places.
- Do not expose the remote control sensor to strong lighting, in particular, an inverter type fluorescent lamp; otherwise, the remote control may not work properly. If necessary, position the system away from direct lighting.

## Adjusting the Clock

Before starting playback operation, follow the procedure below to adjust the clock setting of the receiver.

### Notes

- Use the remote control to set the clock. You cannot set the clock with the buttons on the receiver.
- The receiver supports 24-hour clock display.
- If you do not touch any key for 90 seconds, the receiver returns to normal mode.

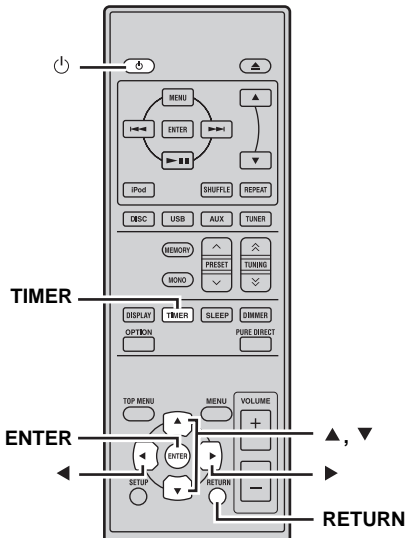

### 1 Press to turn the receiver on.

The front panel display lights up.

### 2 Press **TIMER** to show the current time.

If the clock is not set, "SET TIME" flashes on the display.  
Press **ENTER** to proceed to step 3.

### 3 Press **▲/▼** to select "TIME", and press **ENTER**.

The receiver enters clock setting mode. The hour digits start flashing.

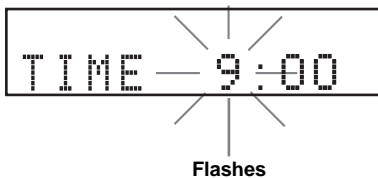

### 4 Set the hour using **▲/▼**, and press **▶**.

The minute digits start flashing.

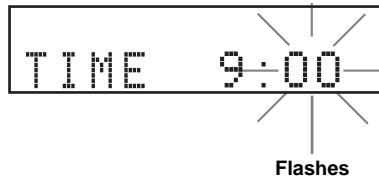

### 5 Set the minutes using **▲/▼**, and press **ENTER**.

The hour and minute digits start flashing.

To change the hour or minutes again, press **▲** or **▼**, do steps 4 and 5, and proceed to step 6.

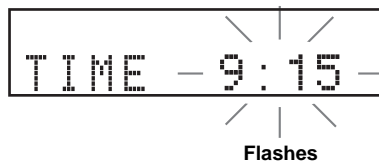

### 6 Press **ENTER**.

The clock is set.

The hour and minute segments stop flashing and remain on. The receiver returns to normal mode.



You can return to the previous screen by pressing **◀** or **RETURN**.

# SETTING THE SYSTEM

## Turn on the TV and the system

Make sure that you have completed all the necessary connections (see “Connecting a TV to the system” on page 9).

- 1 Turn on the TV to which the DVD player is connected.**  
Select the TV input to match the input connected to the DVD player.

- 2 Press  to turn on the receiver.**

- 3 Press DISC.**

## Setting the TV display

Set the aspect ratio of the DVD player according to the TV you have connected. The format you select must be available on the disc. If it is not, the TV display setting will not affect the picture during playback.

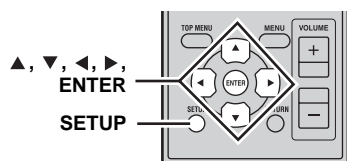

- 1 Press SETUP.**  
The DVD setup menu appears on the screen.

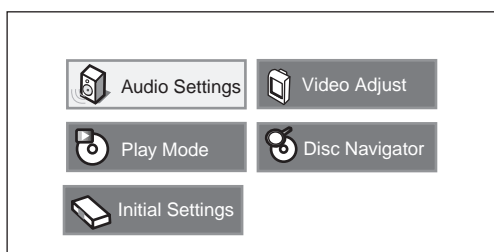

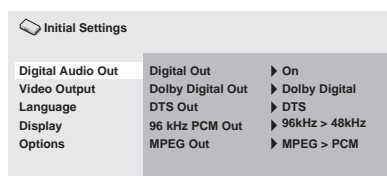

- 2 Press /// to select “Initial Settings”, and then press ENTER.**

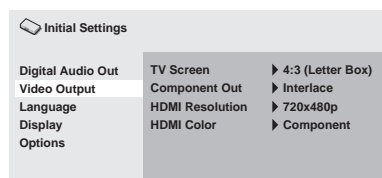

- 3 Press / to select “Video Output”, and then press ENTER.**

- 4 Press / to select “TV Screen”, and then press ENTER.**



- 5 Press / to select one of the options below, and then press ENTER.**

### 4:3 (Letter Box)

Select this if you have a conventional TV. In this case, a wide picture with black bar on the upper and lower portions of the TV screen will be displayed.

### 4:3 (Pan&Scan)

Select this if you have a conventional TV and want both sides of the picture to be trimmed or formatted to fit your TV screen.

#### Note

If the disc does not support an aspect ratio of 4:3 (Pan&Scan), the content is displayed in 4:3 (Letter Box).

### 16:9 (Wide)

Select this if you have a wide-screen TV.

### 16:9 (Compressed)

Select this if a wide-screen TV is connected to the DVD controller with an HDMI cable, and set HDMI Resolution to either “1920 x 1080p”, “1920 x 1080i”, or “1280 x 720p”. When playing back a content whose aspect ratio is 4:3, black bars cover the sides of the screen.



## Selecting the output type for COMPONENT jacks

To use progressive display function, connect to a TV, which has that function, via COMPONENT jacks.

- 1 Press **SETUP**.
- 2 Press **▲/▼/◀/▶** to select “Initial Settings”, and then press **ENTER**.
- 3 Press **▲/▼** to select “Video Output”, and then press **ENTER**.
- 4 Press **▲/▼** to select “Component Out”, and then press **ENTER**.

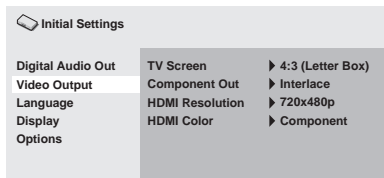

- 5 Press **▲/▼** to select “Progressive / Interlace”, and then press **ENTER**.
- 6 When the confirmation screen appears, press **ENTER** again.  
To cancel the setting, press **RETURN**.

### Note

Do not select “Progressive” if your TV does not have a progressive display function.  
If your TV is also connected via HDMI terminal, the system may ignore this setting and output the progressive signal from COMPONENT jacks.

## Selecting the HDMI audio output

Normally, the speakers connected to the receiver are used to output the sound. However, you may want to listen through your HDMI TV’s speakers, in which case you can turn HDMI audio output on and off as follows.

- 1 Set the DVD player to standby.
- 2 While holding down **□** on the DVD player’s front panel, press **⏻**.  
“DVD — NO REQ.” is displayed.
- 3 Press **◀◀/▶▶** to select “HDMI A-OFF” or “HDMI A-ON”.

- 4 Press **▷/◁** repeatedly to select “HDMI A-ON”.

- 5 Press **⏻**.  
HDMI Audio output is turned on and the DVD player goes on standby. Press **⏻** again to turn it back on.  
To turn HDMI Audio output off, repeat the above procedure but select “HDMI A-OFF” in step 4.

### Note

The audio output by the HDMI jack is always 2-channel PCM.

## On-screen display (OSD) language

You can select your preferred language settings so that the DVD player will automatically switch to your preferred language whenever you load a disc. If the language selected is not available on the disc, the disc’s default setting language will be used instead. The OSD (on-screen display) language for the DVD setup menu will remain as you set it, regardless of various disc languages.

- 1 Press **SETUP**.  
DVD setup menu appears on the screen.
- 2 Press **▲/▼/◀/▶** to select “Initial Settings”, and then press **ENTER**.
- 3 Press **▲/▼** to select “Display”, and then press **ENTER**.

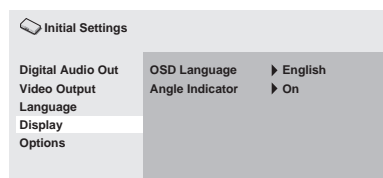

- 4 Press **▲/▼** to select “OSD Language”, and then press **ENTER**.
- 5 Press **▲/▼** to select a language, and then press **ENTER**.

## Audio, Subtitle and Disc menu languages

- 1 Press SETUP.**  
DVD setup menu appears on the screen.
- 2 Press ▲/▼/◀/▶ to select “Initial Settings”, and then press ENTER.**
- 3 Press ▲/▼ to select “Language”, and then press ENTER.**

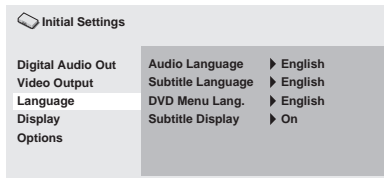

- 4 Press ▲/▼ to select the item below, and then press ENTER.**
  - Audio Language
  - Subtitle Language
  - DVD Menu Language
- 5 Press ▲/▼ to select a language, and then press ENTER.**

# SYSTEM OPERATIONS

Follow the procedure below to select an input source and adjust the sound settings on the system.

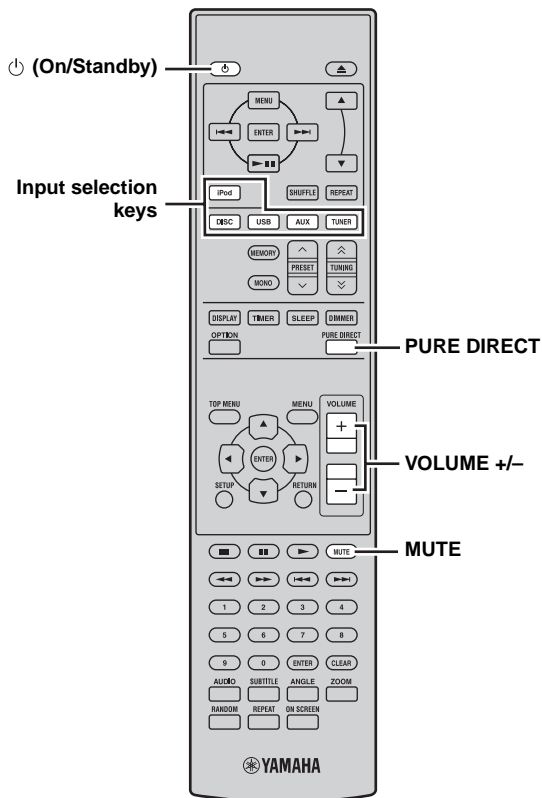
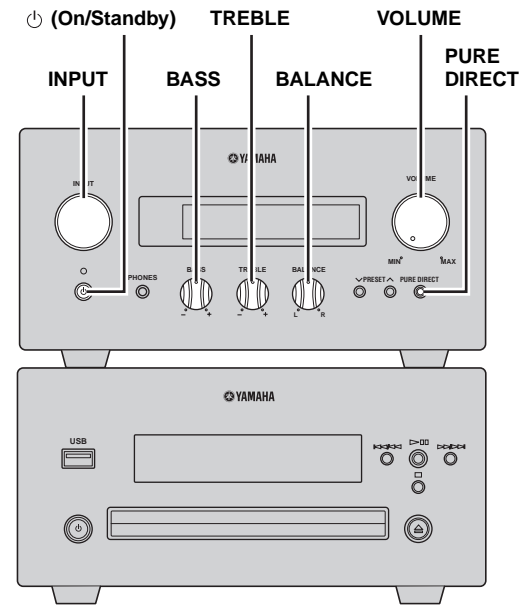

## Basic system operations

### 1 Press **On/Standby** to turn on the receiver.

Depending on input mode of the receiver, the DVD player also turns on by the system control connection (p.8). The front panel display lights up.



This system has an auto-standby function (p.37) which automatically sets it to standby mode if not operated for 30 minutes while the receiver is set to DISC/USB input mode.

### 2 Press one of the input selection keys (or rotate **INPUT** on the front panel) to select the desired input source.

### 3 Start playback on the selected source component or select a radio station.

For information on the disc/USB device playback, see page 19, and for information on tuning, see pages 29 and 33.

### 4 Press **VOLUME +/-** (or turn **VOLUME** on the front panel) to adjust the volume to the desired output level.

### 5 Rotate **BASS**, **TREBLE**, or **BALANCE** on the front panel of the receiver to adjust the following settings.

- BASS:** Adjusts the low frequency response.
- TREBLE:** Adjusts the high frequency response.
- BALANCE:** Adjusts the volume level of each left and right speaker channel.

### ■ Pure Direct mode

Pure Direct mode bypasses the tone control circuit and turns off the front panel display, allowing you to enjoy pure high-fidelity sound.

### Press **PURE DIRECT** (or **PURE DIRECT** on the front panel) to turn on Pure Direct mode.

The front panel display automatically turns off. **PURE DIRECT** on the front panel is backlit in blue.

### Notes

- If you carry out operations while Pure Direct mode is turned on, the front panel display lights up briefly to acknowledge the command.
- While the Pure Direct mode is turned on, neither **BASS**, **TREBLE**, nor **BALANCE** is available.

### To turn off Pure Direct mode

Press PURE DIRECT again. The PURE DIRECT backlight turns off and the front panel display turns on.

### ■ Muting the sound (MUTE)

**Press MUTE to reduce the current volume level by approximately 20dB.**

“MUTE ON” appears on the front panel display. Press MUTE again to restore the audio output to the previous volume level.

## Changing the brightness of the front panel display

You can dim the front panel display of the receiver. The front panel display of the DVD player also dims by the system control connection (p.8). (The default setting is “DIMMER OFF”.)

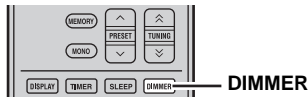

**Press DIMMER.**

You can choose your desired brightness of the front panel display between normal (bright), mid dim, and dim.

## To use headphones

You can connect your headphones to the PHONES jack on the front panel of the receiver.

The sound from the speakers and the subwoofer stops.

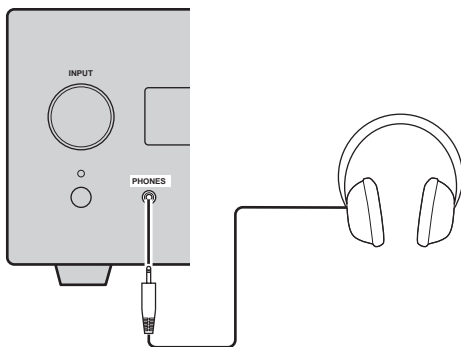

# DISC AND USB DEVICE OPERATIONS

This chapter explains how to play discs/USB devices.

## Using the on-screen display

When the input source is DISC or USB, you can operate various functions and settings by using the on-screen menus that appear on the connected TV.

Button	Description
<b>SETUP</b>	Displays the Setup menu*
<b>Cursor</b> (▲▼)/(◀▶)	Selects menu items
<b>ENTER</b>	Confirms item selection
<b>RETURN</b>	Returns to the previous menu

\* Only when the input source is DISC.



- You can change the language of the on-screen display with the OSD Language setting (p.15).
- The buttons that you can use with each menu are shown at the bottom of each screen.

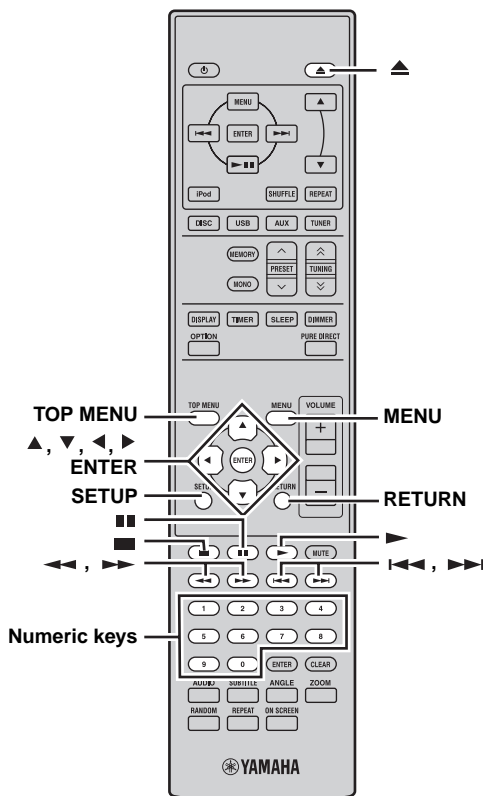

## Playback operations

### ■ To start disc playback

You can play the following types of discs: DVD-Video, DVD-VR (DVD-R/RW/R DL discs recorded in VR mode), VCD, SVCD, Audio CD, and DTS CD. Also, data discs containing the following types of files: MP3, WMA, MPEG-4 AAC, JPEG, DivX® Ultra, and WMV. See page 3 for more details on supported disc types and file formats.

#### 1 Press .

The disc tray opens and the DISC input source is selected automatically. If the receiver was on standby, it will turn on automatically.

To use the on-screen menus or view video or pictures, turn on your TV and select the AV input to which the DVD player is connected.

#### 2 Place the disc, label-side up, in the center of the disc tray, and then press .

The disc tray closes and the disc is loaded.

#### 3 Press .

- If you loaded a DVD, VCD, or SVCD disc, a menu may appear. See “DVD-Video menus” or “VCD and SVCD menu (PBC)” (p.21) for more details.
- If you loaded a disc containing JPEG pictures, a slideshow will start. See “Playing JPEG slideshows” (p.26) for more details.
- If you loaded a disc containing various file formats, such as MP3, WMA, MPEG-4 AAC, JPEG, DivX®, or WMV, you’ll need to select the format you want to play on-screen.

#### Notes

- To play a double-sided DVD, load it with the side you want to play facing down.
- With some discs, some of the playback functions explained in this chapter may not work as expected, and some may not work at all.
- Some DVDs restrict the use of certain functions, for example, random playback or repeat playback, in some or all parts of the disc. This is not a malfunction.

## ■ To start USB device playback

You can enjoy music (MP3, WMA, MPEG-4 AAC) stored on the USB device. You can also play a slideshow of JPEG pictures.

### 1 Select USB as an input source (☞ p.17).

Turn on your TV and select the AV input to which the DVD player is connected.

### 2 Connect your USB device to the USB port on the DVD player.

### 3 Press MENU to display Disc Navigator and select the track you want to play. Or, press ► to start playback of all files on the USB device.

If you loaded a disc containing JPEG pictures, a slideshow will start. See “Playing JPEG slideshows” (☞ p.26) for more details.

#### Notes

- Not all USB storage devices are recognized.
- Only MP3, WMA, MPEG-4 AAC, and JPEG files with no copy protection (DRM) can be played.
- The DVD player supports USB mass storage class devices formatted with FAT16 or FAT32, including USB flash memory devices, digital audio players, and USB hard drives. You cannot connect your computer directly to the DVD player.
- Playback with all USB storage devices, and the ability to power all USB devices is not guaranteed. Yamaha accepts no responsibility whatsoever in the unlikely event that any data is lost while the USB device is connected to the DVD player.
- Large capacity USB devices will take longer to read. High capacity devices may take several minutes to read.
- USB hubs are not supported.
- While the USB input source is selected, the Setup menu will be unavailable.
- Connect only USB devices to the USB port.
- If the message “USB ERROR” appears on the display, the DVD player may not be able to supply enough power to the device for it to function properly. If the device is not a USB device, do not use it with the DVD player. If the USB device came with its own power adapter, use it to power the USB device. If the USB device came with no power adapter, do not use it with the DVD player.

## Stopping playback

Press ■ .

You can also use Stop (□) on the DVD player to stop playback.

If “RESUME” or “LAST MEM” appears on the display after stopping playback, you can resume playback from where you left off simply by pressing ►. See “Resume and Last Memory” below for more details.

## Resume and Last Memory

When you press ■ to stop DVD-Video, VCD, SVCD, DivX<sup>®</sup>, WMV, or Audio CD playback, “RESUME” appears on the display, and you can continue playback from where you left off simply by pressing ►.

For DVD-Video, VCD, and SVCD discs, the DVD player will remember the point at which you stopped playback even if the disc has been ejected. The next time you load the disc, “Last Memory” appears on-screen, and you can continue playback from where you left off.

If you don’t want the DVD player to remember the Last Memory point, instead of pressing ■, press ▲ to stop playback and eject the disc.

To cancel the Resume or Last Memory function, while “RESUME” or “LAST MEM” is displayed, press ■.

#### Notes

- The Last Memory function may not work with some discs.
- The DVD player can remember the Last Memory points for up to five DVD-Video discs and one VCD or SVCD disc.
- For DivX<sup>®</sup>, WMV, and Audio CD discs, the Resume function is cancelled when the disc is ejected, the input source is changed, or the DVD player is set to standby mode.

## Pausing playback

Press ■■.

To resume playback, press ■■ again, or press ►.

You can also use ▷/◁ on the DVD player to pause playback.

## Rewind and fast forward

During playback, you can rewind or fast forward at various speeds.

Press ◀◀ to rewind or ▶▶ to fast forward.

The rewind or forward speed changes each time you press ◀◀ or ▶▶.

The speed is displayed on-screen.

To resume normal playback, press ►.

#### Notes

- For DivX<sup>®</sup> and WMV discs, only one rewind and fast forward speed is available.
- Normal playback may resume when a new chapter (DVD-Video) or track (PBC VCD or SVCD) is reached while rewinding or fast forwarding.
- For MP3, WMA, and MPEG-4 AAC discs, normal playback will resume when the beginning or end of a track is reached while rewinding or fast forwarding.

## Selecting chapters and tracks

### ■ To select the next chapter or track

Press ►►I.

### ■ To select the previous chapter or track

Press I◄◄ twice.

If you press I◄◄ only once, playback returns to the beginning of the current chapter or track.

You can also use ►►I / ►► and I◄◄ / ◄◄ on the DVD player to select the next or previous track.

## Selecting items by number

You can select titles, chapters, and tracks by number.

### 1 Use the numeric keys to enter the number of a title, chapter, or track.

### 2 Press ENTER.

If playback was stopped, playback starts from the specified title (DVD) or track (Audio CD, VCD, SVCD).

If playback was in progress, playback goes to the specified title (DVD-VR [VR mode DVD-R/RW/R DL]), chapter (DVD-Video), or track (VCD, SVCD, or Audio CD).

## DVD-Video menus

Most DVD-Video discs have menus from which you can select what you want to watch. Usually, the main menu appears automatically, although with some discs, you may need to press MENU or TOP MENU to display the menu. The following buttons can be used with menus.

Button	Description
TOP MENU	Displays the DVD's top menu *1
MENU	Displays a DVD's menu *2
(▲▼)/(◄►)	Selects menu items
ENTER	Confirms item selection
RETURN	Returns to the previous menu
Numeric keys	With some discs, playback can be started by entering a number and pressing ENTER.

\*1 Depends on the disc. With some DivX® discs, a menu will be displayed.

\*2 May work the same as the TOP MENU button with some discs.

## VCD and SVCD menus (PBC)

Some VCD and SVCD discs have PBC (Playback Control) menus from which you can select what you want to watch.

### 1 Load a PBC VCD or SVCD disc.

### 2 Press ►.

The PBC menu appears.

### 3 Use the numeric keys to enter the number of the track you want to play.

### 4 Press ENTER.

The following buttons can be used with menus.

Button	Description
RETURN	Displays the PBC menu when pressed during playback
Numeric keys	Select numbered menu items. Press ENTER to confirm selection.
►►I	Displays the next menu page (if available)
I◄◄	Displays the previous menu page (if available)

You can turn off PBC and start playback by pressing ►►I or I◄◄ or the number buttons and ENTER while playback is stopped.

### Notes

- With some PBC VCD and SVCD discs, the menu may not appear when you press ►. In this case, press RETURN during playback to display the menu.
- Some of the disc playback functions explained in this chapter cannot be used with PBC playback. To use such a function, turn off PBC playback by starting playback without using the menu, as explained above.
- If you turn off PBC temporarily, the menu will not be displayed when RETURN is pressed during playback. To display the menu again, press ■ twice, and then press ►. PBC will be turned on and pressing RETURN will display the menu.

## Slow-motion playback

You can play DVD-Video, VCD, SVCD, DivX<sup>®</sup>, and WMV discs in slow motion at four different speeds. You can also play DVD-Video discs in reverse slow motion.

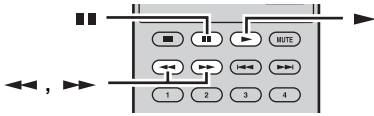

**1** During playback, press **PAUSE**.

**2** Press and hold down **REVERSE SLOW MOTION** or **SLOW MOTION** until slow-motion playback starts.

■ To change the slow-motion speed

Press **REVERSE SLOW MOTION** or **SLOW MOTION** repeatedly.

The speed is displayed on-screen.

■ To resume normal playback

Press **PLAY**.

### Note

Normal playback may resume when a new chapter (DVD-Video) or track (PBC VCD or SVCD) is reached during slow-motion playback.

## Frame-by-frame playback

You can play DVD-Video, VCD, SVCD, DivX<sup>®</sup>, and WMV discs frame-by-frame. You can also play DVD-Video discs frame-by-frame in reverse.

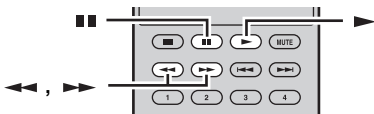

**1** During playback, press **PAUSE**.

**2** Press **REVERSE FRAME-BY-FRAME** or **FRAME-BY-FRAME** to play one frame at a time.

■ To resume normal playback

Press **PLAY**.

### Note

Normal playback may resume when a new chapter (DVD-Video) or track (PBC VCD or SVCD) is reached during frame-by-frame playback.

## Selecting languages and audio

Some DVD discs have soundtracks in multiple languages or audio formats, such as Dolby Digital and DTS, that you can select during playback. Similarly, some DVD-VR (VR mode DVD-R/RW/R DL) discs have dual-mono audio soundtracks, and some DivX<sup>®</sup> discs have multiple audio soundtracks.

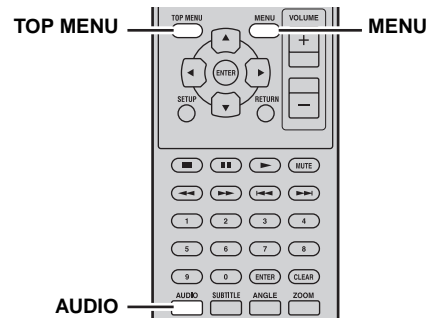

During playback, press **AUDIO** repeatedly to select the available soundtrack languages or audio formats.

The name of the selected language or audio format is displayed on-screen.

### Notes

- With some discs, you can only select language soundtracks and audio formats by using the disc's menu. Use **TOP MENU** and **MENU** to display the disc's menu.
- You can change the default soundtrack language for DVD-Video discs in the "Language settings" (see p.42).
- The default soundtrack language (see p.42) may be selected if you stop playback and cancel the Resume function, or eject the disc without storing the Last Memory point (see p.20).

## Selecting subtitles

Some DVD and DivX<sup>®</sup> discs have subtitles in one or more languages that you can select during playback.

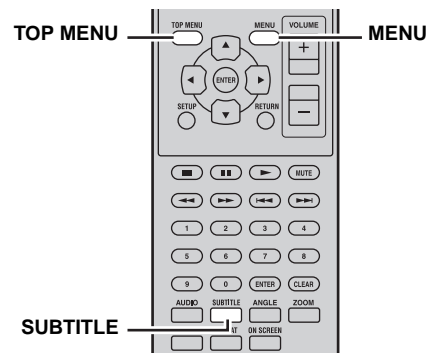



**During playback, press SUBTITLE repeatedly to select the available subtitles.**

The name of the selected subtitle language is displayed on-screen.

**Notes**

- With some discs, you can only select subtitles by using the disc's menu. Use TOP MENU and MENU to display the disc's menu.
- You can change the default subtitle language for DVD-Video discs in the "Language settings" (p.42).
- See "About DivX<sup>®</sup>" (p.50) for details on using DivX<sup>®</sup> subtitles.
- With some DivX<sup>®</sup> discs, the subtitles may not display correctly.
- The default subtitle language (p.42) may be selected if you stop playback and cancel the Resume function, or eject the disc without storing the Last Memory point (p.20).

**Selecting camera angles**

Some DVD-Video discs have content recorded at multiple camera angles that you can select during playback. A camera icon ( ) appears on-screen when playing content that features multiple camera angles. You can turn this icon off if you prefer (p.43).

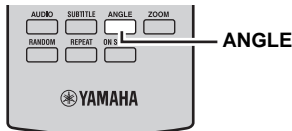

**During playback, press ANGLE repeatedly to select the available camera angles.**

**Notes**

- With some discs, even though the camera icon ( ) is displayed on-screen, you may not be able to select the camera angles.
- With some discs, you can also select the camera angles from the disc's menu.

**Zoom**

You can zoom the picture 2x or 4x when playing DVD-Video, VCD, SVCD, DivX<sup>®</sup>, WMV, or JPEG data on a disc or USB device.

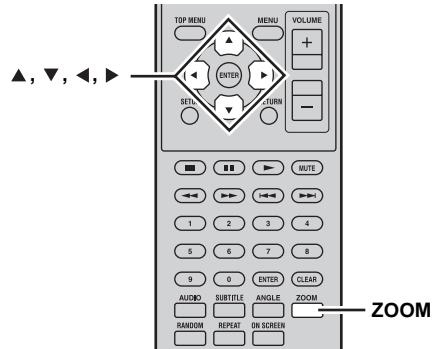

**1 During playback, press ZOOM repeatedly to select 2x, 4x, or 1x zoom.**

**2 Use ▲/▼/◀/▶ to move around the picture while zoomed in.**

You can change the zoom factor and move around the picture freely while playback continues.

**Notes**

- Since DVD-Video, VCD, SVCD, DivX<sup>®</sup>, WMV, and JPEG data use a fixed video resolution, the picture quality may deteriorate when zoomed in. This is not a malfunction.
- If the zoom indicator disappears from the screen, press ZOOM again to display it.

**Repeat playback**

You can play a title, chapter, track, or disc repeatedly. Repeat playback can be combined with program playback to play a compilation of your favorite titles, chapters, or tracks repeatedly (p.25).

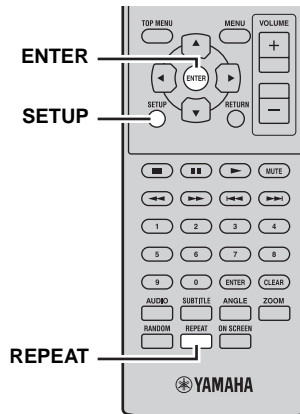

**1 During playback, press SETUP.**

The Setup menu appears on-screen.

**2 Select “Play Mode”, and then press ENTER.**

The Play Mode menu appears on-screen.

**3 Select “Repeat”, select a repeat option, and then press ENTER.**

The available repeat options differ depending on the type of disc.

- For DVD discs, you can select “Title Repeat” or “Chapter Repeat”.
- For VCD, SVCD, and Audio CD discs, you can select “Disc Repeat” or “Track Repeat”.
- For DivX® and WMV discs, you can select “Title Repeat”. With some DivX® discs, you can also select “Chapter Repeat”.
- During program playback (p.25), you can select “Program Repeat”.

■ **To cancel repeat playback**

Select “Repeat Off”, and then press ENTER.

■ **To close the Setup menu**

Press SETUP.



- You can select the repeat option quickly by pressing REPEAT repeatedly.

**Note**

Repeat playback cannot be used with MP3, WMA, MPEG-4 AAC, and JPEG discs.

**A–B repeat playback**

You can specify two points (A and B) on a DVD, VCD, SVCD, or Audio CD, and then play the section between those two points repeatedly.

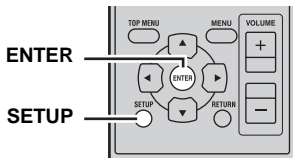

**1 During playback, press SETUP.**

The Setup menu appears on-screen.

**2 Select “Play Mode”, and then press ENTER.**

The Play Mode menu appears on-screen.

**3 Select “A-B Repeat”, and then press ENTER.**

**4 Select “A(Start point)”, and then press ENTER.**

**5 Select “B(End point)”, and then press ENTER.**

The section between points A and B is played back repeatedly.

■ **To resume normal playback**

Select “Off”, and then press ENTER.

■ **To close the Setup menu**

Press SETUP.

**Note**

The A and B points must be within the same title (DVD) or track (VCD, SVCD, Audio CD).

**Random playback**

You can play titles or chapters (DVD-Video) or tracks (VCD, SVCD, or Audio CD) in random order.

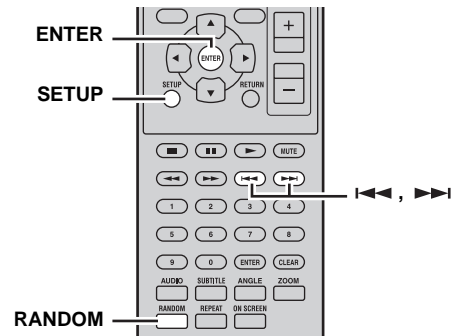

**1 During playback, press SETUP.**

The Setup menu appears on-screen.

**2 Select “Play Mode”, and then press ENTER.**

The Play Mode menu appears on-screen.

**3 Select “Random”, select a random option, and then press ENTER.**

The available random options differ depending on the type of disc.

- For DVD discs, you can select “Random Title” or “Random Chapter”.
- For VCD, SVCD, and Audio CD discs, you can select “On”.

■ **To cancel random playback**

Select “Random Off”, and then press ENTER.

## ■ To close the Setup menu

### Press SETUP.



- During random playback, press ►► to select another title, chapter, or track. Press ◀◀ to return to the beginning of the current title, chapter, or track.
- You can select the random option quickly by pressing RANDOM repeatedly.

### Notes

- You cannot combine random playback with program playback.
- Random playback cannot be used with DVD-VR (VR mode DVD-R/RW/R DL), DivX<sup>®</sup>, WMV, JPEG, MP3, WMA, or MPEG-4 AAC discs, or while a DVD menu is displayed.

## Program playback

You can create a program of your favorite titles, chapters, or tracks for playback.

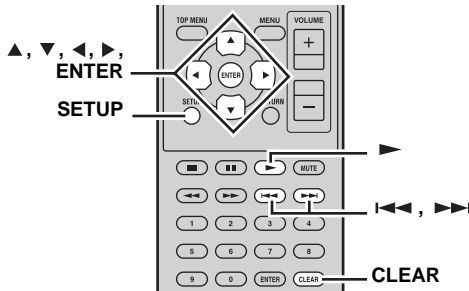

### 1 During playback, press SETUP.

The Setup menu appears on-screen.

### 2 Select “Play Mode”, and then press ENTER.

The Play Mode menu appears on-screen.

### 3 Select “Program”, select “Create/Edit” from the list of program options, and then press ENTER.

### 4 Use ▲/▼/◀/▶ to select a title, chapter, or track, and press ENTER to add it to the program.

The selected item is added to the program and the program step moves down.

- For DVD discs, you can add titles or chapters to the program.
- For Audio CD, VCD, and SVCD discs, you can add tracks to the program.

### 5 Repeat step 4 to add more items to the program.

You can add up to 24 items to the program.

- To insert a new item in the program, select the step where you want to insert it, select the title, chapter, or track you want to insert, and then press ENTER.
- To delete a step, select it, and then press CLEAR.

### 6 Press ► to start the program.

The items in the program are played in order. During playback, use ►► and ◀◀ to select subsequent and earlier items in the program.

### Notes

- The program will be deleted when the disc is ejected, an input source other than DISC is selected, or DVD player is set to standby mode.
- Program playback cannot be used with DVD-VR (VR mode DVD-R/RW/R DL), DivX<sup>®</sup>, WMV, JPEG, MP3, WMA, or MPEG-4 AAC discs, or while a DVD menu is displayed.

## ■ To close the Setup menu

### Press SETUP.

### ■ Program menu options

In addition to “Create/Edit”, the Program menu has the following options:

- **Playback Start:** Starts program playback.
- **Playback Stop:** Turns off program playback, but keeps the program in memory.
- **Playback Delete:** Deletes the program.

## Searching Discs

You can search through a disc by title, chapter, or track number, or by time.

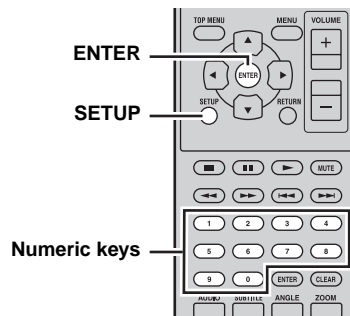

### 1 During playback, press SETUP.

The Setup menu appears on-screen.

### 2 Select “Play Mode”, and then press ENTER.

The Play Mode menu appears on-screen.

### 3 Select “Search Mode”, select a search option, and then press ENTER.

The available search options are different depending on the type of disc.

- For DVD discs, you can select “Title Search”, “Chapter Search”, or “Time Search”.
- For VCD, SVCD, and Audio CD discs, you can select “Track Search” or “Time Search”.
- For DivX® and WMV discs, you can select “Time Search”. For some DivX® discs, you can also select “Chapter Search”.

**Note**

Time Search can only be selected during playback and only works within the current title or track.

**4 Use the numeric keys to enter a title, chapter, or track number, or a time.**

Times are entered in minutes and seconds. To enter the time 45 minutes, for example, press 4, 5, 0, and 0. To enter 1 hour, 20 minutes, and 30 seconds, press 8, 0, 3, and 0.

**5 Press ENTER to locate and play the specified title, chapter, track, or time.**

**■ To close the Setup menu**

Press **SETUP**.

**Note**

For DivX® and WMV discs, the located time may differ from the specified time by a few seconds.

**Playing JPEG slideshows**

You can play a slideshow of JPEG pictures on a data disc or USB device.

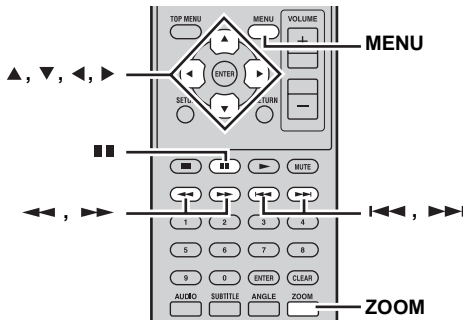

**Load the disc or connect the USB device to the DVD player, and then press ► to start the slideshow.**

Starting with the first picture in the first folder, the slideshow displays every picture in every folder on the disc/USB in alphabetical order.

The pictures will be scaled automatically so that they appear on-screen at the largest size possible.

The following buttons can be used during slideshow.

Button	Description
■	Pauses the slideshow (or music playback if the disc/USB device contains music files)
▶▶	Select the next picture (or track if the disc/USB device contains music files)
◀◀	Select the previous picture (or track if the disc/USB device contains music files)
(▲▼)/(◀▶)	Pauses the slideshow and rotates and flips the current picture. To resume the slideshow, press ▶.
ZOOM	Pauses the slideshow and zooms the current picture. Press repeatedly to select 2x, 4x, or 1x zoom. To resume slideshow playback, press ▶.
MENU	Displays Disc Navigator (see below)

**Notes**

- Large pictures take longer to load and may not appear immediately.
- On a single disc or USB device, the DVD player supports up to 299 folders, and each folder may contain a combination of up to 648 files and folders.
- If the disc/USB device contains JPEG picture files and music files (MP3, WMA, MPEG-4 AAC), the music files will play repeatedly during the slideshow. And, ■, ▶▶, ◀◀, ◀, and ▶ will control music playback, not the slideshow.

**Using Disc Navigator with DVD-Video, VCD, and SVCD discs**

You can use Disc Navigator to browse and select titles, chapters, and tracks on DVD, VCD, and SVCD discs.

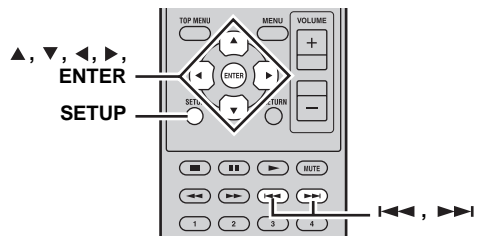

**1 During playback, press SETUP.**

The Setup menu appears on-screen.

## 2 Select "Disc Navigator", and then press ENTER.

A list of items appear on-screen. The items available depends on the type of disc.

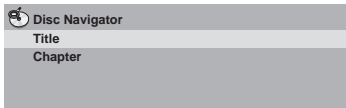

The following items are available for each disc type.

Disc	Item
DVD-Video	Title
	Chapter*1
VCD, SVCD	Track
	Time
DVD-VR (VR mode DVD-R/RW/R DL)*2	Original: Title
	Original: Time
	Playlist: Title
	Playlist: Time

\*1 Only chapters within the current title can be selected.

\*2 Recordings made on a DVD recorder are called *original titles*. Edited recordings based on those original titles are called *playlist titles*.

## 3 Select the type of item you want to browse, and then press ENTER.

Six thumbnail images appear on-screen showing content of the type you specified. If you selected "Time", the thumbnails will display the content at 10 minute intervals.

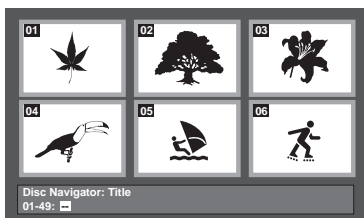

## 4 Use >>> and <<< to view other thumbnail pages if available.

## 5 Use the ▲/▼/◀/▶ to select the thumbnail you want to play, and then press ENTER.

The selected item starts playing. You can also use the number buttons and ENTER to select the thumbnails.

## Using Disc Navigator with MP3, WMA, MPEG-4 AAC, DivX<sup>®</sup>, WMV, and JPEG discs/USB devices

You can use Disc Navigator to browse and select MP3, WMA, MPEG-4 AAC, DivX<sup>®</sup>, WMV, and JPEG files on data discs or USB devices.

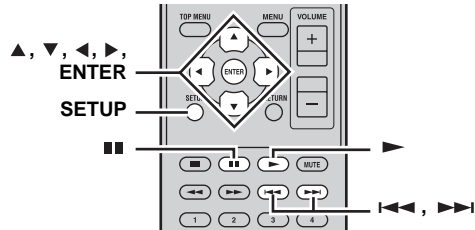

## 1 Press SETUP.

The Setup menu appears on-screen.

## 2 Select "Disc Navigator", and then press ENTER.

Disc Navigator appears on-screen.

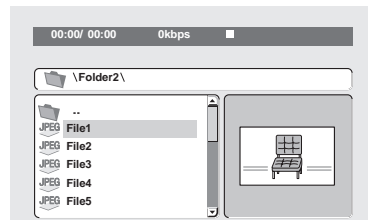

## 3 Use the ▲/▼/◀/▶ to select the track, file, or folder you want to play.

- Use ▲/▼ to move up and down the file and folder list.
- Use ◀ to move back up the directory tree one level. Or, select the folder at the top of the list (...) and press ENTER.
- Use ENTER or ▶ to open the selected folder. When you select a JPEG picture file, Disc Navigator displays a thumbnail preview.

## 4 Press ENTER to play back the selected track, file or folder.

If you selected an MP3, WMA, MPEG-4 AAC, DivX<sup>®</sup>, or WMV file, starting with that file, all of the files in the same folder will be played.

If you selected a JPEG picture file, starting with that file, all of the files in the same folder will be played in a slideshow.

■ To close the Setup menu

Press **SETUP**.



- If the disc contains JPEG picture files and music files (MP3, WMA, MPEG-4 AAC), you can listen to music while watching a slideshow. Simply start music playback as described above, and then select a JPEG picture file and start slideshow playback. All of the files within the current folders will be played repeatedly. And, ►, ■■, ►►, and ◀◀ will control the slideshow, not music playback.
- Disc Navigator only plays the files in the current folder. To play all of the files on the USB device, close Disc Navigator and start playback by pressing ►, see “Playing JPEG slideshows” (p.26).

**Viewing disc information**

You can view title, chapter, track, and other information during playback.

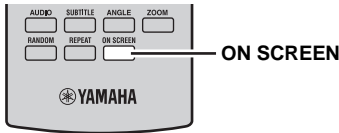

During playback, press **ON SCREEN** repeatedly to display the information.

■ To hide the information

Press **ON SCREEN** repeatedly until it disappears.

Some information, such as remaining disc time, is also displayed on the DVD player’s display.

**Viewing the audio format**

You can view audio format during playback.

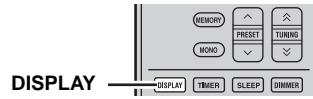

During playback, press **DISPLAY**.

The audio format appears on the DVD player’s display. Possible audio formats are listed below.

Display	Description
<b>PCM</b>	PCM (DVD-Video disc)
<b>Dolby D</b>	Dolby Digital (DVD-Video disc)
<b>MPEG2</b>	MPEG2 (DVD-Video disc)
<b>DTS</b>	DTS (DVD-Video disc)
<b>CDDA</b>	Audio CD
<b>VCD</b>	Video CD
<b>SVCD</b>	Super video CD
<b>DTS CD</b>	DTS CD
<b>DATA</b>	MP3, WMA, MPEG-4 AAC, DivX®, WMV, or JPEG

**Note**

The audio format can be viewed only when the DISC or USB input source is selected and playback is in progress.

# DAB (DIGITAL AUDIO BROADCASTING) TUNING

DAB (Digital Audio Broadcasting) uses digital signals for clearer sound and more stable reception compared to analog signals.

This unit can also receive DAB+ (an upgraded version of DAB) that allows for more stations using MPEG-4 audio codec (AAC+), which has a more efficient transmission method.

## Preparing the DAB tuning

Before tuning into DAB stations, an initial scan must be performed. The initial scan starts automatically when you select DAB as the input source for the first time.

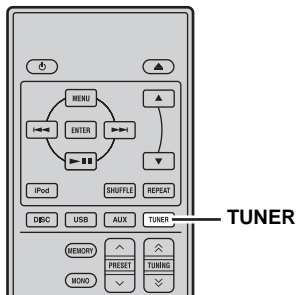

You can also perform the initial scan manually by INIT SCAN (see p.31).

**1 Press TUNER repeatedly to set the unit to the DAB mode.**

**2 The initial scan starts automatically.**

While the scan is in progress, "SCAN" and the percentage of the progress of scan appear on the front panel display.

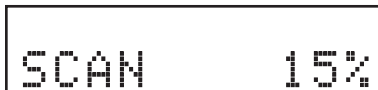

When scanning is complete, the number of receivable DAB stations appears on the front panel display for a while, then the unit airs the first station as stored in station order.



## Tuning DAB stations

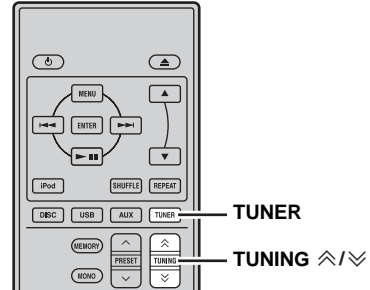

**1 Press TUNER repeatedly to set the unit to the DAB mode.**

**2 Press TUNING  to select a DAB station.**

Some stations have sub (secondary) stations. The secondary indicator lights up when a secondary audio station is selected.

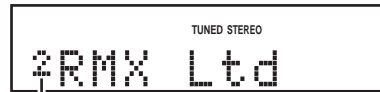

Secondary indicator



You can change the order of DAB stations by STATION ORDER (see p.31).

### Note

When the unit cannot receive the DAB signal, "OFF AIR" is displayed on the front panel display.

## DAB station information

### Switching the information of DAB

Use this feature to display various information about the DAB service currently being received.

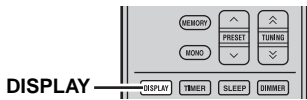

Press **DISPLAY** repeatedly while receiving DAB.

#### STATION LABEL

Displays the name of the current DAB station and preset number.

#### DLS (Dynamic Label Segment)

Displays information about the current DAB station, such as the name of the song, artist and speaker, etc. This data is continuously updated by the DAB broadcaster, thus changing often with every new song or program.

Other data, such as news, weather, and sports headlines, may be broadcast as well.

#### ENSEMBLE LABEL

Displays the name of the current ensemble.

#### PROGRAM TYPE

Displays the genre of the current DAB station.

#### TIME

Displays the current time.

#### BITRATE

Displays the bitrate of the current DAB station.

#### CHANNEL/FREQ

Displays the channel label and frequency of the current DAB station (see p.32).

#### SIGNAL QUALITY

Displays signal reception quality (from 0 (none) to 100 (best)) of current DAB tuning.

#### AUDIO FORMAT

Displays the audio format of the current station, and whether DRC (Dynamic Range Control)\* is activated. “(DRC ON)” is displayed when DRC MODE (see p.31) is set to AUTO and DRC information is transmitted by DAB station.

\* Some DAB broadcasters transmit a wide dynamic range enabling high quality sound, accompanied by DRC information.

Use this feature to compress the dynamic range of the DAB broadcast. This is especially useful when you listen to a DAB station in a noisy environment or at low volume at night.



You can change the DRC setting by DRC MODE (see p.31).

## Presetting DAB stations

You can store your favorite DAB stations with the preset function.

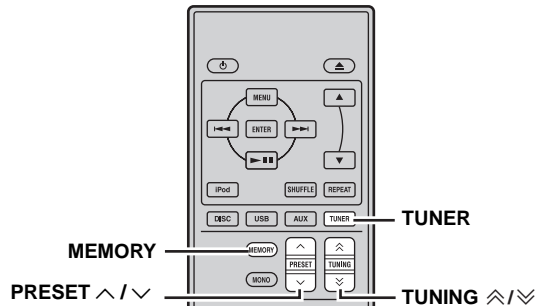

**1 Press TUNER repeatedly to set the unit to the DAB mode.**

**2 Press TUNING  $\wedge/\vee$  to tune into a favorite DAB station.**

**3 Press MEMORY.**  
To cancel the preset, press MEMORY again.

**4 Press PRESET  $\wedge/\vee$  repeatedly to select a preset number you want to store, and press MEMORY.**



- You can preset up to 30 DAB stations.
- You can delete a preset station by PRESET DELETE (see p.31).

## Selecting preset DAB stations (Preset tuning)

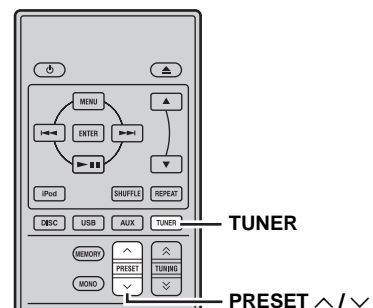

**1 Press TUNER repeatedly to set the unit to the DAB mode.**

**2 Press PRESET  $\wedge/\vee$  to select a preset DAB station.**

The PRESET indicator lights up in the front panel display.



## Using DAB option menu

You can set the following functions in DAB option menu.

Function	Description
PRESET DELETE	Deletes unnecessary preset DAB stations.
STATION ORDER	Enables you to change the station order.  <b>ALPHA-NUMERIC:</b> Stations are listed in alphabetical order. <b>ENSEMBLE:</b> Stations are listed in ensemble order. The default setting is "ALPHA-NUMERIC".
DRC MODE	Changes the DRC (☞p.30) setting.  <b>AUTO:</b> This unit utilizes DRC automatically if it is transmitted. <b>OFF:</b> This unit does not utilize DRC. The default setting is "AUTO".
DAB CLEAR	Deletes all DAB station information and preset settings stored in the unit. After DAB CLEAR is complete, the unit moves to the INIT SCAN functions automatically. Note that once DAB CLEAR is performed, the deleted information and preset settings cannot be restored.
INIT SCAN	Performs the initial scan manually. Each time you perform INIT SCAN, the newly received stations are added to the previously received stations.
TUNE AID	Measures reception strength of the received DAB signal (from 0 (none) to 100 (best)). Refer to "TUNE AID" (☞p.32) for this operation.
AUTO CLOCK	Automatically adjusts the receiver clock using the DAB broadcast signal.

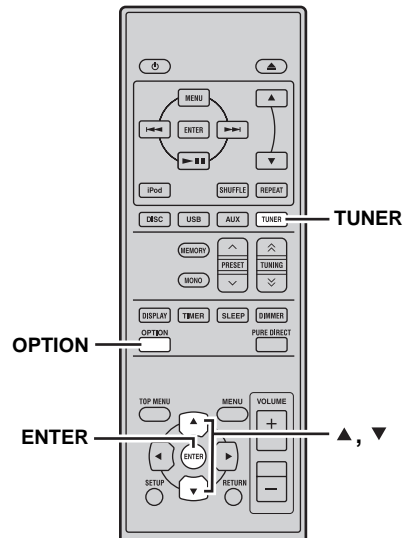

### ■ PRESET DELETE, STATION ORDER and DRC MODE

- 1 Press **TUNER** repeatedly to set the unit to the **DAB mode**.
- 2 Press **OPTION** to display the **DAB option menu**. Press **▲/▼** repeatedly to select the function you want to use and press **ENTER**.
- 3 **Select and set the desired setting.**  
For **PRESET DELETE**, press **▲/▼** repeatedly to select preset number you want to delete and press **ENTER**.

### ■ DAB CLEAR and INIT SCAN

- 1 Press **TUNER** repeatedly to set the unit to the **DAB mode**.
- 2 Press **OPTION** to display the **DAB option menu**. Press **▲/▼** repeatedly to select **DAB CLEAR** or **INIT SCAN** and press **ENTER**.  
"Push ENTER" appears on the front panel display.
- 3 Press **ENTER** to perform the function.  
If you select **DAB CLEAR**, all DAB information is deleted; when **INIT SCAN**, the initial scan starts.

## ■ TUNE AID

**1** Press **TUNER** repeatedly to set the unit to the DAB mode.

**2** Press **OPTION** to display the DAB option menu. Press **▲/▼** to select **TUNE AID** and press **ENTER**.

**3** Press **▲/▼** to select a channel label you want to measure.

Adjust the indoor DAB antenna to the best position for receiving the DAB signal.

**4** Press **ENTER** to finish measuring.

### Note

To check the frequency corresponding to the channel label, refer to “DAB frequency information” to the right.

## ■ AUTO CLOCK

**1** Press **TUNER** repeatedly to set the unit to the DAB mode.

**2** Press **OPTION** to display the DAB option menu. Press **▲/▼** to select **AUTO CLOCK** and press **ENTER**.

**3** Press **▲/▼** to select “ON” or “OFF”, and press **ENTER**.

The “AUTO CLOCK” status is displayed.

The default setting is “ON”.

ON: Automatically adjusts the receiver clock using the DAB broadcast signal.

OFF: Does not adjust the receiver clock.

## DAB frequency information

This unit can receive Band III only.

Frequency	Channel label
174.928 MHz	5A
176.640 MHz	5B
178.352 MHz	5C
180.064 MHz	5D
181.936 MHz	6A
183.648 MHz	6B
185.360 MHz	6C
187.072 MHz	6D
188.928 MHz	7A
190.640 MHz	7B
192.352 MHz	7C
194.064 MHz	7D
195.936 MHz	8A
197.648 MHz	8B
199.360 MHz	8C
201.072 MHz	8D
202.928 MHz	9A
204.640 MHz	9B
206.352 MHz	9C
208.064 MHz	9D
209.936 MHz	10A
211.648 MHz	10B
213.360 MHz	10C
215.072 MHz	10D
216.928 MHz	11A
218.640 MHz	11B
220.352 MHz	11C
222.064 MHz	11D
223.936 MHz	12A
225.648 MHz	12B
227.360 MHz	12C
229.072 MHz	12D
230.784 MHz	13A
232.496 MHz	13B
234.208 MHz	13C
235.776 MHz	13D
237.488 MHz	13E
239.200 MHz	13F

# FM TUNING

There are 2 tuning methods: automatic and manual. You can also use the automatic and manual preset tuning features to store up to 30 stations.

## Automatic tuning

Automatic tuning is effective when station signals are strong and there is no interference.

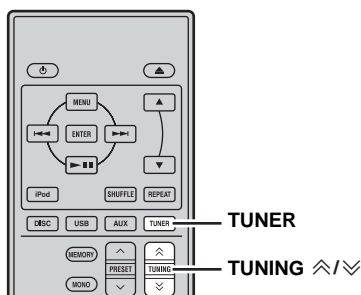

**1 Press TUNER to set the receiver to FM mode.**

**2 Press and hold TUNING  $\wedge/\vee$  for more than 2 seconds to begin automatic tuning.**

When the receiver is tuned into a station, the TUNED indicator lights up and the frequency of the received station is shown on the front panel display.

- Press  $\vee$  to tune into a lower frequency.
- Press  $\wedge$  to tune into a higher frequency.

## Manual tuning

If the signal received from the station you want to select is weak, tune into it manually.

**1 Press TUNER to set the receiver to FM mode.**

**2 Press TUNING  $\wedge/\vee$  to tune into the desired station manually.**

## Automatic preset tuning

Follow the procedure below to preset radio stations automatically.

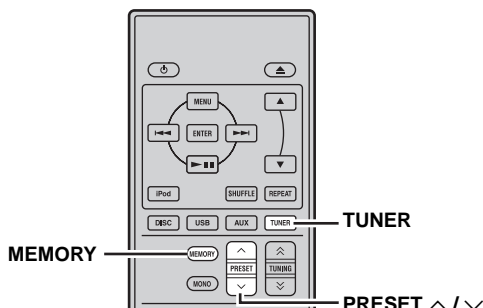

**1 Press TUNER to set the receiver to FM mode.**

**2 Press and hold MEMORY for more than 2 seconds.**

The PRESET indicator starts flashing on the front panel display and automatic station preset starts. When all frequencies are searched, preset stops automatically.

- The search starts at the lowest frequency and goes toward the highest frequency.
- The receiver automatically applies a preset number to each detected station.
- To cancel the search, press MEMORY.

### Notes

- You can preset up to 30 FM stations.
- Any stored station data existing under a preset station number is cleared when you store a new station under the same preset station number.

## Manual preset tuning

You can store up to 30 stations.

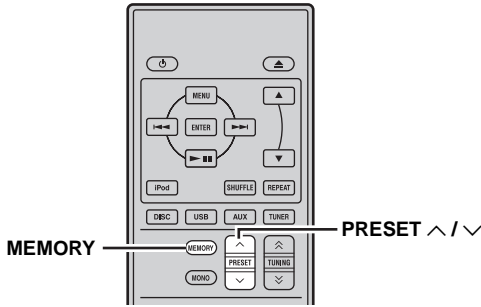

- 1 Tune into a radio station you want to preset.**  
See page 33 for tuning instructions.

---

- 2 Press MEMORY.**  
The PRESET indicator flashes on the front panel display for about 5 seconds.

---

- 3 Press PRESET ^ / v repeatedly to select a preset station number while the PRESET indicator is flashing.**

---

- 4 Press MEMORY to store while the PRESET indicator is flashing.**  
The PRESET indicator lights up on the front panel display.

---

- 5 Repeat steps 1 to 4 until all desired stations are preset.**

## Selecting preset stations

You can tune into any desired station simply by selecting the preset station under which it was stored (see p.33).

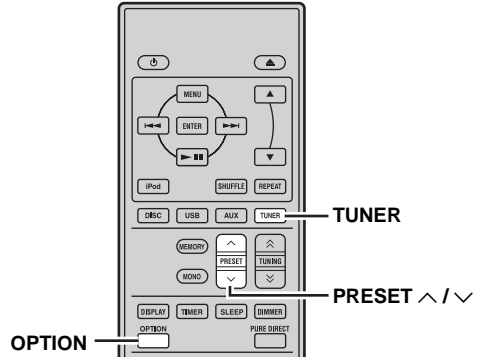

**Press PRESET ^ / v repeatedly to select a preset station.**



- You can also use the front panel to select preset stations. Press PRESET ^ / v repeatedly to select a preset station.
- When you press PRESET ^ / v on the front panel of the receiver in standby mode, the receiver automatically activates the tuner and tunes in to the preset station that you selected previously.

### ■ To delete the preset station

- 1 Press TUNER to set the unit to FM mode.**

---

- 2 Press OPTION to display the option menu. Press ^ / v to select "PRESET DEL" and press ENTER.**

---

- 3 Press ^ / v to select the preset number you want to delete and press ENTER.**  
The preset station is now deleted.  
You can continue to delete preset stations on this screen. Repeat steps 2 and 3 until all unnecessary stations are deleted.

### To cancel deleting operation

Press OPTION.

# SETTING THE TIMER

The receiver is equipped with 2 types of timer functions. The DVD player also turns on or sets to standby mode automatically by the system control connection (p.8).

## Setting the clock timer

The clock timer automatically turns the receiver on or sets it to standby mode at the specified time. You can also specify an input which the receiver automatically selects when the clock timer turns it on.

### Notes

- You cannot set the clock timer unless you adjust the clock (p.13).
- If you do not touch any key for more than 30 seconds after the previous key operation, the operations you made are cleared from the memory and the normal display reappears.

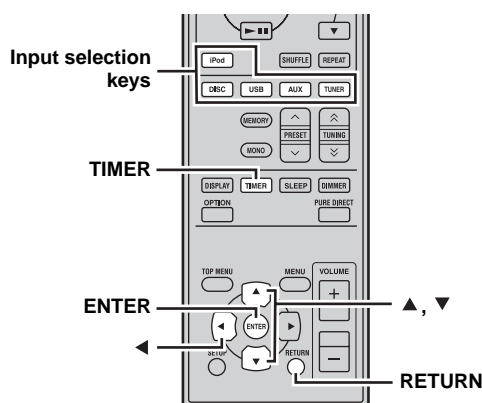
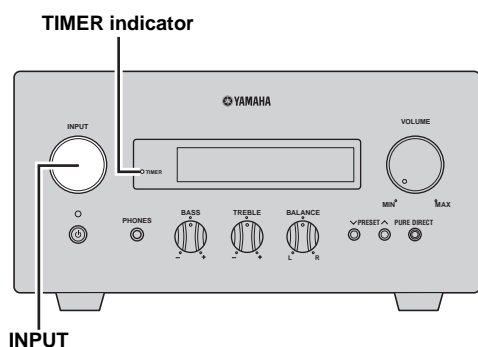

- 1 Press TIMER and ▲/▼ to select “TIMER”, and then press ENTER.**

The receiver enters timer setting mode. The TIMER indicator flashes on the front panel display.

- 2 Press ▲ or ▼ to select “ON” (timer enabled) or “OFF” (timer disabled), and press ENTER.**

ON: The timer clock setting screen appears. Proceed to step 3.

OFF: The TIMER indicator turns off and the receiver returns to normal mode.

### Note

To disable the timer, select “OFF”. Once the timer is enabled, the timer setting and the TIMER indicator remain on until “OFF” is selected.

- 3 Set the starting time of the timer.**

For details on how to set the clock, see steps 4 through 6 of “Adjusting the Clock” (p.13).

- 4 Press ▲/▼ or an input selection key to select the input source to be used when the timer turns on the receiver, and press ENTER.**

The receiver automatically selects the input source when it is turned on by the clock timer.

If FM is selected as the input source, the preset number (e.g. “P01”) is shown on the front panel display. Press ▲/▼ to select the preset number of the station you want to hear when the timer is activated, and press ENTER.

If you select “---” (default), the receiver selects the station that you previously tuned in to.

If no station is registered as a preset station, “---” is shown. Press ENTER and proceed to step 5.

You can only select a preset station. Register a station that you want to hear when the timer is activated as a preset station in advance (p.34).

### Note

You cannot select AUX as an input source.

- 5 Press ▲/▼ to set the operation time length of the receiver.**

You can select a length of time from 30 to 90 minutes in 10-minute steps. Select “---” if you do not want the receiver to automatically go to standby mode.

- 6 Press ENTER to complete the timer setting.**

The TIMER indicator lights up.

- 7 Press ⏻ to set the receiver to standby mode.**

The receiver will be turned on automatically at the specified time.

**To cancel the timer setting operation**

Press **TIMER** during the operation.



You can return to the previous screen by pressing ◀ or **RETURN**.

***Setting the sleep timer***

The sleep timer sets the receiver to standby mode after the specified time elapses.

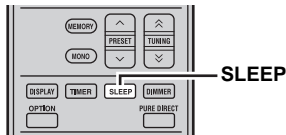

**Press **SLEEP** repeatedly to select the desired duration.**

Each time you press the key, the duration changes as follows.

The **SLEEP** indicator lights up on the front panel display.

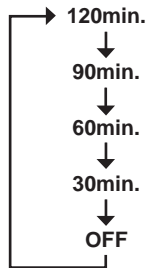

- The sleep timer is canceled if you set the receiver to standby mode.
- If you press **SLEEP** once while the sleep timer is set, the ongoing duration appears on the front panel display.

**To cancel the sleep timer**

Press **SLEEP** repeatedly to select “OFF”.

# SETTING THE AUTO-STANDBY MODE

The auto-standby function automatically sets the system to standby mode when DISC or USB is selected as input source and the system is not operated for 30 minutes.

## Notes

- Unless you connect the receiver and the DVD player with the supplied system control cable properly (p.8), this feature does not function for the system.
- This feature does not function for the system during playback.

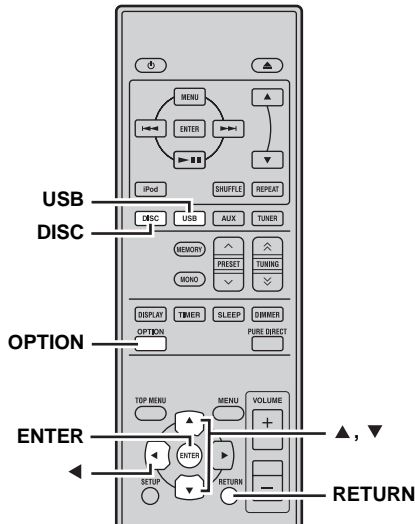

### 1 Press DISC or USB to select an input source, and press OPTION.

“AUTO STBY” appears on the front panel display of the receiver.

### 2 Press ENTER.

The current setting is displayed.

### 3 Press ▲/▼ to select “ON” or “OFF”.

The default setting is “ON”.

### 4 Press ENTER to confirm the setting.

“AUTO STBY” reappears on the display.

### 5 Press OPTION.

The receiver returns to normal mode.

### To cancel the setting operation

Press OPTION during the operation.



You can return to the previous screen by pressing ◀ or RETURN.

# CONTROLLING iPod™

In addition to controlling the receiver (R-840) and DVD player (DVD-840), you can operate your iPod stationed in the iPod dock using the supplied remote control.

## Using iPod™

Once you have stationed your iPod to the iPod dock, you can enjoy playback of your iPod using the supplied remote control.

When connecting the iPod during the playback, this system automatically changes to iPod mode.

### Notes

- Only iPod (Click and Wheel), iPod nano, iPod Classic, iPod mini and iPod touch are supported.
- Some features may not be compatible depending on the model or the software version of your iPod.



For a complete list of status messages that appear on the front panel display of the receiver, see the “iPod” section in “TROUBLESHOOTING” (p.47).

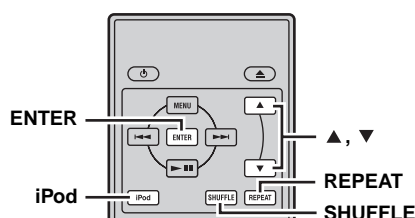

- Operate the iPod using the iPod controls or the supplied remote control.

### ■ Repeating playback (Repeat Play)

You can play back a single track or a group of tracks on your iPod repeatedly.

#### Press REPEAT.

Each time you press the key, mode of Repeat Play changes. The following chart is an example of how mode changes as you press the key. Check currently selected mode on your iPod screen.

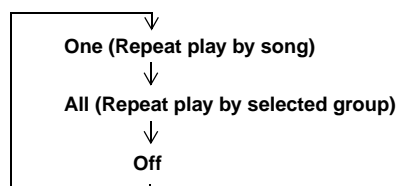

### ■ Playing back randomly (Shuffle Play)

You can play back songs or albums on your iPod randomly.

#### Press SHUFFLE.

Each time you press the key, mode of Shuffle Play changes. The following chart is an example of how mode changes as you press the key. Check currently selected mode on your iPod screen.

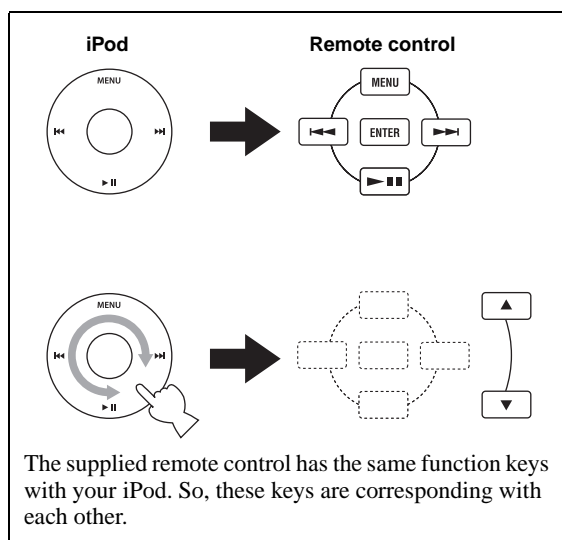
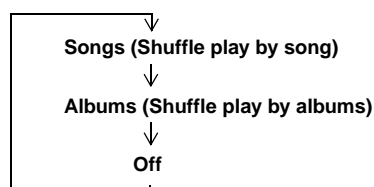

- 1 Press iPod to select the iPod as the input source.**
- 2 Station your iPod to the iPod dock.**
- 3 Press ▲/▼ to operate the iPod menu, and then press ENTER to start playback of the selected song (or group).**
  - View the screen of the iPod to control the menu.



# DVD SETUP MENU OPTIONS

This chapter explains the Audio Settings menu, the Video Adjust and Initial Settings menus.

## Audio Settings menu

These settings only affect disc playback.

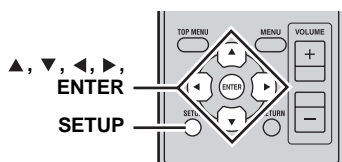

**1 Press DISC and then SETUP.**  
The Setup menu appears on-screen.

**2 Select “Audio Settings”, and then press ENTER.**  
The Audio Settings menu appears on-screen.

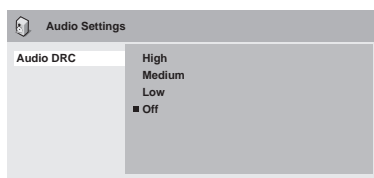

**3 Use ▲/▼/◀/▶ and ENTER to select and change the settings.**  
The settings are explained below.

**4 Press SETUP to close the Setup menu.**

### Note

The effects of the Audio settings depends on your speakers, TV, and AV receiver's volume level and other settings. For each setting, switch between the available options and choose the one that provides the best results.

### ■ Audio DRC

The Audio DRC (Dynamic Range Control) function makes loud sounds quieter and quiet sounds louder, which is ideal for watching movies late at night when you don't want to disturb anyone.

- High, Medium, Low, Off (default).

### Notes

- Audio DRC only works with Dolby Digital sources.
- With some discs, Audio DRC may have little or no effect.
- The Audio DRC function also applies to digital output signals when the Digital Out setting is set to On and the Dolby Digital Out setting is set to Dolby Digital > PCM. See page 40 for details on the digital audio output settings.

- The Audio DRC function also applies to audio output from the HDMI output, with the same restrictions as above.

### ■ Dialog

When watching a movie or other material on a DVD-Video disc, depending on the audio format, the center channel may be too quiet and difficult to hear. With the Dialog function, you can make the dialog louder and easier to hear.

- High, Medium, Low, Off (default).

### Notes

- When using the Dialog function, depending on the source material, the dialog may distort, in which case you should select a lower setting.
- The Dialog function also applies to digital output signals that have been converted to 2-channel PCM. See page 40 for details on the digital audio output settings.
- The Dialog function also applies to audio output from the HDMI output, with the same restrictions as above.

## Video Adjust menu

The Video Adjust settings affect the TV picture.

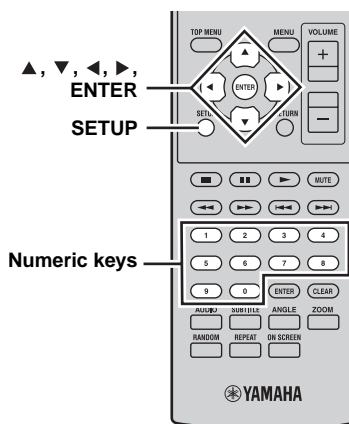

**1 Press DISC and then SETUP.**  
The Setup menu appears on-screen.

### Note

The Video Adjust menu is only available when DVD is selected as an input source.

## 2 Select "Video Adjust", and then press ENTER.

The Video Adjust menu appears on-screen.

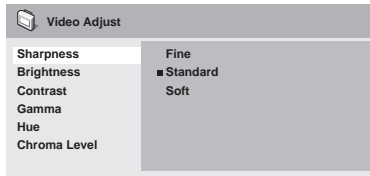

## 3 Use ▲/▼/◀/▶ and ENTER to select and change the settings.

The settings are explained below.

The Brightness, Contrast, Hue, and Chroma Level settings can be adjusted by using ◀/▶.



## 4 Press SETUP to close the Setup menu.

### ■ Sharpness

Adjusts the sharpness of edges in the picture.

- Fine, Standard (default), Soft.

### ■ Brightness

Adjusts the brightness of the picture.

- -20 to +20 (default: 0)

### ■ Contrast

Adjusts the contrast between the lightest and darkest areas of the picture.

- -16 to +16 (default: 0)

### ■ Gamma

Adjusts the appearance of dark areas of the picture.

- High, Medium, Low, Off (default).

### ■ Hue

Adjusts the balance between green and red.

- green 9 to red 9 (default: 0)

### ■ Chroma Level

Adjusts the color saturation.

- -9 to +9 (default: 0)

#### Notes

- The effects of the Video Adjust settings depends on the source material and your TV, and in some cases may not be that visible.
- The Sharpness setting does not apply to video output by the HDMI jack.

## Initial Settings menu

The Initial Settings menu contains digital audio output, video, language, display, and other settings.

When a menu item is grayed out, it means that it cannot currently be changed. The Initial Settings cannot be changed during disc playback.

## 1 Press DISC and then SETUP.

The Setup menu appears on-screen.

## 2 Select "Initial Settings", and then press ENTER.

The Initial Settings menu appears on-screen.

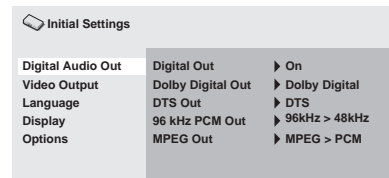

## 3 Use ▲/▼/◀/▶ and ENTER to select and change the settings.

The settings are explained below.

#### Notes

- The HDMI Resolution and HDMI Color settings only need to be changed if you've connected an HDMI component to the HDMI jack.
- The Component Out settings cannot be changed if you've connected an HDMI component to the HDMI jack.
- The Component Out settings may change automatically due to the HDMI Resolution and HDMI Color settings.
- While HDMI Audio is set to on (Ⓜp.15), or a component is connected to the HDMI jack, only the Digital Out setting is available.
- When HDMI Audio is set to on (Ⓜp.15), 96 kHz PCM is downsampled to 48 kHz regardless of the 96 kHz PCM Out setting.

### ■ Digital Audio Out settings

#### Digital Out

Turns the OPTICAL DIGITAL OUT on and off.

- **On (default):** OPTICAL DIGITAL OUT is on.
- **Off:** OPTICAL DIGITAL OUT is off.

#### Dolby Digital Out

Turns Dolby Digital to PCM conversion on and off. If you've connected the OPTICAL DIGITAL OUT to your AV receiver/decoder and it doesn't support Dolby Digital, select Dolby Digital > PCM.

- **Dolby Digital (default):** Dolby Digital signals are output as they are.
- **Dolby Digital > PCM:** Dolby Digital signals are converted and output as 2-channel PCM.

## DTS Out

Turns DTS to PCM conversion on and off. If you've connected the OPTICAL DIGITAL OUT to your AV receiver/decoder and it doesn't support DTS, select DTS > PCM.

- **DTS (default):** DTS signals are output as they are.
- **DTS > PCM:** DTS signals are converted and output as 2-channel PCM.

### Notes

- If you select DTS and your AV receiver/decoder doesn't support DTS, noise may be heard.
- When DTS > PCM is selected, you can also choose the type of DTS downmix (see "DTS Downmix" on page 43).

## 96 kHz PCM Out

Turns 96 kHz downsampling on and off. If you've connected the OPTICAL DIGITAL OUT to your AV receiver/decoder and it supports 96 kHz PCM, select 96 kHz.

- **96 kHz > 48 kHz (default):** 96 kHz PCM digital audio signals are downsampled and output at 48 kHz.
- **96 kHz:** 96 kHz PCM digital audio signals are output as they are.

## MPEG Out

Turns MPEG to PCM conversion on and off. If you've connected the OPTICAL DIGITAL OUT to an AV receiver/decoder that supports MPEG, select MPEG.

- **MPEG:** MPEG signals are output as they are.
- **MPEG > PCM (default):** MPEG signals are converted and output as 2-channel PCM.

## ■ Video Output settings

### TV Screen

Sets the aspect ratio of the picture output by the analog and HDMI video outputs. Choose an option that matches the aspect ratio of your TV.

- **4:3 (Letter Box) (default):** Select if you have a conventional 4:3 TV. Widescreen movies will be displayed with black bars top and bottom.
- **4:3 (Pan & Scan):** Select if you have a conventional 4:3 TV. Widescreen movies will be displayed with the sides trimmed so that the picture fills the entire screen. Video from discs that do not support Pan & Scan will be output in 4:3 Letter Box format.
- **16:9 (Wide):** Select if you have a widescreen TV.
- **16:9 (Compressed):** This option can only be selected if your TV is connected to the HDMI jack and the HDMI Resolution setting is set to 1920 x 1080p, 1920 x 1080i, or 1280 x 720p. Select this if you want to properly display 4:3 content on a widescreen TV. Black bars will be displayed on either side of the picture.

### Component Out

Sets the COMPONENT to interlaced or progressive video output. Progressive scanning offers better picture quality and reduced picture noise.

If your TV or projector supports progressive scanning, select Progressive. Refer to your TV owner's manual for details.

- **Interlace (default):** The COMPONENT outputs interlaced video.
- **Progressive:** The COMPONENT VIDEO OUT outputs progressive video and the PROGRESSIVE indicator on the display lights up.

To use progressive video, select the Progressive option and press ENTER. When the confirmation message appears on-screen, press ENTER to confirm, or press RETURN to cancel.

### Notes

- When you switch between Interlace and Progressive, the picture may be disturbed.
- When the HDMI Resolution is set to 720 x 480i (NTSC) or 720 x 576i (PAL), the Component Out setting is forcibly set to Interlace. When another resolution is selected, the Component Out setting is forcibly set to Progressive.
- If you select Progressive inadvertently and your TV doesn't support it, you may lose the picture altogether. In this case, connect the DVD player to a TV with a composite video connection and change the setting back to Interlace, or reset the DVD player (see p.56).
- CONSUMERS SHOULD NOTE THAT NOT ALL HIGH DEFINITION TELEVISION SETS ARE FULLY COMPATIBLE WITH THIS PRODUCT AND MAY CAUSE ARTIFACTS TO BE DISPLAYED IN THE PICTURE. IN CASE OF 525 PROGRESSIVE SCAN PICTURE PROBLEMS, IT IS RECOMMENDED THAT YOU SWITCH THE CONNECTION TO THE "STANDARD DEFINITION" OUTPUT. IF THERE ARE QUESTIONS REGARDING YOUR VIDEO MONITOR COMPATIBILITY WITH THIS UNIT, PLEASE CONTACT OUR CUSTOMER SERVICE CENTER.

### HDMI Resolution

Sets the HDMI output video resolution.

- **1920 x 1080p:** Select if your HDMI TV supports 1080p progressive video.
  - **1920 x 1080i:** Select if your HDMI TV supports 1080i interlace video.
  - **1280 x 720p:** Select if your HDMI TV supports 720p progressive video.
  - **720 x 480p (NTSC), 720 x 576p (PAL) (default):** Select if your HDMI TV supports 480p or 576p progressive video.
  - **720 x 480i (NTSC), 720 x 576i (PAL):** Select if your HDMI TV supports 480i or 576i interlace video.
- To change the resolution, select a resolution, and then press ENTER. When the confirmation message appears on-screen, press ENTER to confirm.

### Notes

- When you change the resolution, the picture may be disturbed and may not appear immediately.
- Resetting the HDMI settings

If no picture is displayed after changing the resolution, use the procedure below to revert to the default resolution of 720 x 480p (NTSC), 720 x 576p (PAL).

- 1 **Set the DVD player to standby.**

---

- 2 **While holding down  $\square$  on the DVD player, press  $\circlearrowleft$ .**

---

- 3 **Release  $\circlearrowleft$  when “DVD — NO REQ.” is displayed on the front panel display.**

---

- 4 **Press  $\lll/\lll/\ggg/\ggg$  repeatedly to select “HDMI CLEAR”.**  
To quite resetting, select “DVD — NO REQ.” instead.

---

- 5 **Press  $\circlearrowleft$ .**  
The HDMI Resolution is reset to its default setting and the DVD player enters standby mode. Press  $\circlearrowleft$  again to turn it back on. The HDMI Audio setting (p.15) is set to off.

## HDMI Color

Sets the HDMI color output.

- **Full range RGB:** Provides very bright whites and deep blacks.
- **RGB:** Select this if white and black areas of the picture are too pronounced with the Full range RGB option.
- **Component:** This is the standard component video format used by HDMI components.

The default setting changes depending on the connected HDMI component.

## ■ Language settings

For the Other Languages options of the Audio Language, Subtitle Language, and DVD Menu Lang. settings, you can also specify the language by using the 2-letter abbreviations or 4-digit codes listed on page 57.

- 1 **Select “Other Languages”, and then press ENTER.**

---

- 2 **Use  $\blacktriangle/\blacktriangledown$  to select a language by abbreviation.**  
For some languages, only the code number is displayed.  
To specify a language by using the 4-digit codes, use  $\blacktriangle/\blacktriangledown/\blacktriangleleft/\blacktriangleright$  or the numeric keys to enter the appropriate code, and then press ENTER.

## Audio Language

Sets the default soundtrack language to be used with DVD-Video discs.

- **English (default):** English soundtrack will be used if available.
- **(Languages):** Selected language will be used if available. (Available languages differ depending on where you purchased this system.)

- **Other Languages:** Use the language abbreviations and codes listed on page 57 to specify languages not listed above.

## Notes

- With some DVD-Video discs, the soundtrack language will be set by the disc regardless of this setting.
- With some DVD-Video discs, you can select the soundtrack language from a menu. In this case, press MENU to display the menu, and then select the soundtrack language.

## Subtitle Language

Sets the default subtitle language to be used with DVD-Video discs.

- **English (default):** English subtitles will be used if available.
- **(Languages):** Subtitles in the selected language will be used if available. (Available languages differ depending on where you purchased this system.)
- **Other Languages:** Use the language abbreviations and codes listed on page 57 to specify languages not listed above.

## Notes

- With some DVD-Video discs, the subtitle language will be set by the disc regardless of this setting.
- With some DVD-Video discs, you can select the subtitle language from a menu. In this case, press MENU to display the menu, and then select the subtitle language.
- The Subtitle Language setting also applies to DivX<sup>®</sup> discs that use external subtitle files (see “About DivX<sup>®</sup>” on page 50).

## DVD Menu Lang.

Sets the default language to be used for menus on DVD-Video discs and some DivX<sup>®</sup> discs.

- **w/Subtitle Lang. (default):** Menus in the same language as that specified for the Subtitle Language setting will be used if available.
- **(Languages):** Menus in the selected language will be used if available. (Available languages depends on where you purchased this system.)
- **Other Languages:** Use the language abbreviations and codes listed on page 57 to specify languages not listed above.

## Subtitle Display

Determines whether DVD-Video disc subtitles are displayed by default.

- **On (default):** Subtitles are displayed by default if available.
- **Off:** Subtitles are not displayed by default.

## Note

Some DVD-Video discs may forcibly display subtitles regardless of this setting.

## ■ Display settings

### OSD Language

Sets the language of the on-screen menus.

- **English (default):** English on-screen menus.

- **Language:** Available languages depends on where you purchased this system.

### Angle Indicator

Determines whether the camera icon () is displayed on-screen when playing content on a DVD-Video disc that features multiple camera angles.

- **On (default):** Camera icon is displayed.
- **Off:** Camera icon is not displayed.

### ■ Option settings

#### Parental Lock

See “Parental Lock” below.

#### DTS Downmix

Determines how multichannel DTS audio is downmixed when the DTS Out setting (p.41) is set to DTS > PCM. Select Lt/Rt if your AV receiver/decoder supports Dolby Pro Logic but not DTS and it's connected to the OPTICAL DIGITAL OUT.

- **STEREO (default):** Multichannel DTS is downmixed in to a 2-channel stereo mix.
- **Lt/Rt:** Multichannel DTS is downmixed in to a matrix-encoded surround mix that is compatible with Dolby surround matrix decoders.

#### DivX(R) VOD

See “DivX(R) VOD” (p.44).

### ■ Parental Lock

DVD-Video discs containing content that may not be suitable for everyone may use the parental lock system to restrict viewing. (See the disc's case for details.) You can set the DVD player so that discs with a high parental lock level cannot be played without first entering a password. There are eight parental lock levels.

In addition, some DVD-Video discs use country or region codes to block unsuitable content based on the country or region that you set on the DVD player.

To use parental lock, you must first enter a password, set the parental lock level, and specify your country or region. By default, no password is set.

- **Password:** Used to set the password.
- **Level Change:** Used to set the parental lock level.
- **Country Code:** Used to specify your country or region.

#### Setting the password

You must set a password before the Level Change and Country Code settings can be set.

---

**1 Select “Password”, and then press ENTER.**

---

**2 Use the numeric keys to enter a 4-digit password.**

The numbers appear on-screen as asterisks (\*).

---

**3 Press ENTER.**

The password is set.

#### Notes

- We recommend that you make a note of the password. If you forget it, you'll need to reset the DVD player (p.56) and set a new password.
- When the password and parental lock level have been set, when you attempt to play a disc that exceeds the set parental lock level, you'll be prompted to enter the password and playback will not be possible unless you enter the correct password.
- Instead of preventing disc playback completely, some DVD-Video discs may just skip unsuitable scenes.
- Not all DVD-Video discs support parental lock and those that don't can be played regardless of these parental lock settings.

#### Changing the password

To change the password, you'll need to enter the old password.

---

**1 Select “Password Change”, and then press ENTER.**

---

**2 Use the number buttons to enter the old password, and then press ENTER.**

---

**3 Enter a new password, and then press ENTER.**

The new password is set.

#### Setting the parental lock level

Discs with unsuitable content have higher levels; discs with content suitable for all have lower levels. To restrict, for example, playback of discs with a parental level of 4 or higher, set the DVD player to level 3.

---

**1 Select “Level Change”, and then press ENTER.**

---

**2 Use the numeric keys to enter the password, and then press ENTER.**

---

**3 Use </> to set the parental lock level, and then press ENTER.**

The parental lock level is set.

#### Setting your country or region

You can specify the country or region by using the 2-letter abbreviations or 4-digit codes listed on page 57.

---

**1 Select “Country Code”, and then press ENTER.**

---

**2 Use the numeric keys to enter the password, and then press ENTER.**

---

**3 Use ▲/▼ to select your country or region by abbreviation, and then press ENTER.**

To specify your country or region by using the 4-digit codes, use ▲/▼ or the numeric keys to enter the appropriate code, and then press ENTER.

The country or region is set.

**Note**

The new country or region code setting will take effect the next time you load a disc. If a disc is already loaded, you must eject and reload it for the new setting to take effect.

**■ DivX(R) VOD**

To play DivX<sup>®</sup> VOD (Video on Demand) files on the DVD player, you may need to provide a DivX<sup>®</sup> VOD registration code to your DivX<sup>®</sup> VOD content provider. In this case, use the DivX<sup>®</sup> VOD registration code displayed by the Display setting.

**Viewing the DivX<sup>®</sup> VOD registration code**

---

**1 Press SETUP.**

The Setup menu appears on-screen.

---

**2 Select “Initial Settings”, and then press ENTER.**

The Initial Settings menu appears on-screen.

---

**3 Select “Options”, then “DivX(R) VOD”, then “Display”, and then press ENTER.**

The DivX<sup>®</sup> VOD registration code is displayed.

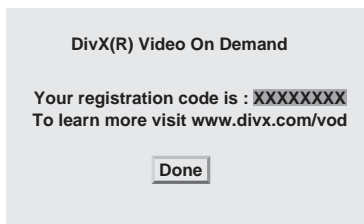
**Notes**

- DivX<sup>®</sup> VOD files use DRM (Digital Rights Management) copy protection and can only be played on the registered player.
- If you attempt to play a DivX<sup>®</sup> VOD file that is not authorized for playback on your DVD player, the message “Authorization Error” will be displayed and playback will not be possible.
- Some DivX<sup>®</sup> VOD files can only be played a limited number of times. When you play such a file on the DVD player, the remaining number of plays will be displayed on-screen. If you attempt to play a file with no plays remaining, the message “Rental Expired” will be displayed and playback will not be possible. DivX<sup>®</sup> VOD files with no playback limit do not display the number of plays remaining and can be played as many times as you like.

# TROUBLESHOOTING

Refer to the table below when this system does not function properly. If the problem you are experiencing is not listed below or if the instruction below does not help, turn off this system, disconnect the power cable, and contact the nearest authorized Yamaha dealer or service center.

## Receiver (R-840)

### ■ General

Problem	Cause	Remedy	See page
<b>The receiver fails to turn on or enters standby mode soon after the power is turned on.</b>	The power cable is not connected or the plug is not completely inserted.	Connect the power cable firmly.	8
	The receiver has been exposed to a strong external electric shock (such as lightning or strong static electricity).	Set the receiver to standby mode, disconnect the power cable, plug it back in after 30 seconds and then use it normally.	—
	The cable is short-circuited and the protection circuitry has been activated.	Make sure that all speaker wire connections on the receiver and on all speakers are secure and that the wire for each connection does not touch anything other than its respective connection.	8
	The internal temperature is too high, the protection circuitry has been activated.	Wait about 1 hour for the receiver to cool down and then turn it back on.	8
<b>No sound</b>	Incorrect input or output cable connections.	Connect the cables properly. If the problem persists, the cables may be defective.	8
	No appropriate input source has been selected.	Select an appropriate input source with the INPUT selector on the front panel (or the input selection keys on the remote control).	—
	Speaker connections are not secure.	Secure the connections.	8
	The volume is turned down.	Turn up the volume.	—
	The sound is muted.	Press MUTE or VOLUME +/- to resume audio output and then adjust the volume.	7
	Signals the receiver cannot reproduce are being input from a source component, such as a CD-ROM.	Play a source whose signals can be reproduced by the receiver.	—
<b>The sound suddenly goes off.</b>	The timer has turned off the receiver.	Turn on the receiver, and play the source again.	—
<b>Sound is heard from the speaker on one side only.</b>	Cables are not connected properly.	Connect the cables properly. If the problem persists, the cables may be defective.	8
<b>There is noise interference from digital or radio frequency equipment.</b>	The receiver is too close to the digital or high-frequency equipment.	Move the receiver further away from such equipment.	—
<b>The sound is distorted.</b>	The volume level is too high.	Adjust the volume level.	17
<b>“CHK SP WIRE” appears on the display.</b>	Speaker cables are short-circuited.	Make sure speaker cables are connected correctly.	8

## ■ DAB reception

Problem	Cause	Remedy	See page
<b>Cannot tune into any DAB stations.</b>	The initial scan operations were not performed.	Perform the initial scan operations.	31
	There is no DAB coverage in your area.	Check with your dealer or WorldDMB online at <a href="http://www.worlddab.org">http://www.worlddab.org</a> for a listing of the DAB coverage in your area.	—
	The DAB signals are too weak.	Use the TUNE AID feature to locate the best positioning of the indoor DAB antenna.	32
<b>The initial scan operations are not successful and “Not found” appears on the front panel display.</b>	The DAB signals are too weak.	Use the TUNE AID feature to locate the best positioning of the indoor DAB antenna.	32
	There is no DAB coverage in your area.	Check with your dealer or WorldDMB online at <a href="http://www.worlddab.org">http://www.worlddab.org</a> for a listing of the DAB coverage in your area.	—
<b>The DAB station reception is weak.</b>	The positioning of the indoor DAB antenna and/or this unit is not optimal for DAB reception.	Use the TUNE AID feature to locate the best positioning of the indoor DAB antenna and this unit for optimal DAB reception.	32
	The DAB signals are too weak.	Use the TUNE AID feature to locate the best positioning of the indoor DAB antenna.	32
<b>There is noise interference (e.g. hiss, crackle or jitter).</b>	The indoor DAB antenna needs to be repositioned.	Readjust the position of the indoor DAB antenna.	8
	The DAB signals are too weak.	Use the TUNE AID feature to locate the best positioning of the indoor DAB antenna.	32
<b>The DAB station information does not appear or is inaccurate.</b>	The DAB station may be temporarily out of service, or the DAB station information is not provided by the DAB broadcaster.	Contact the DAB broadcaster.	—

## ■ FM

Problem	Cause	Remedy	See page
<b>FM stereo reception is noisy.</b>	The characteristics of FM stereo broadcasts may cause this problem when the transmitter is too far away or the antenna input is poor.	Check the antenna connections.	8
		Try using a high-quality directional FM antenna.	—
<b>There is distortion, and clear reception cannot be obtained even with a good FM antenna.</b>	There is multi-path interference.	Adjust the antenna position to eliminate multi-path interference.	—
<b>The desired station cannot be tuned into with the automatic tuning method.</b>	The signal is too weak.	Use a high-quality directional FM antenna.	—
		Use the manual tuning method.	33
<b>Previously preset stations can no longer be tuned into.</b>	The receiver has been disconnected for a long period.	Set preset stations.	33



## ■ iPod

### Note

If a transmission error occurs but no status message is displayed on the front panel display of the receiver, check the connection between the receiver and your iPod (Ⓜp.11).

Status message	Cause	Remedy	See page
CONNECT ERR	There is a problem with the signal path from your iPod to the receiver.	Turn off the receiver and try resetting your iPod.	11
UNKNOWN TYP	The iPod being used is not supported by the receiver.	Only iPod (Click and Wheel), iPod nano, iPod Classic, iPod mini and iPod touch are supported.	—
CONNECTED	Your iPod is properly stationed in the iPod dock, and the connection between your iPod and the receiver is complete.		
NOT CONNECT	Your iPod was removed from the iPod dock of the receiver.	Station your iPod back to the iPod dock of the receiver.	11
CAN'T PLAY	The receiver cannot play back the songs currently stored on your iPod.	Check that the songs currently stored on your iPod are playable. Store some other playable music files on your iPod.	— —

## Remote control

Problem	Cause	Remedy	See page
<b>The remote control does not work nor function properly.</b>	The remote control may be operated outside its operation range.	For information on the remote control operation range, see "Using the remote control".	12
	The remote control sensor on this system may be exposed to direct sunlight or lightening (invented fluorescent lamps).	Change the lighting or orientation of this system.	12
	The battery may be worn out.	Replace the battery with new one.	12
	There are obstacles between the sensor of this system and the remote control.	Remove the obstacles.	12
	The system control cable is disconnected from the system connector jack of the receiver and/or the DVD player.	Connect the receiver and the DVD player securely with the system control cable.	8

## DVD player (DVD-840)

Problem	Cause	Remedy	See page
<b>Power does not turn on.</b>	The plug is not completely inserted.	Connect the power cable firmly.	8
	The receiver and the DVD player are connected incorrectly.	Connect the system control cable properly between the receiver and the DVD player.	8
	The receiver is set incorrectly.	Check the setting (INPUT/Volume/MUTE/Headphone) of the receiver.	—

<b>Problem</b>	<b>Cause</b>	<b>Remedy</b>	<b>See page</b>
<b>Power suddenly shuts off during playback.</b>	The auto-standby function of the receiver works when the receiver does not receive a playing signal transmitted from the DVD player via the system control cable for 30 minutes.	Check the connection of the system control cable between the receiver and the DVD player.	8
<b>No sound or distorted sound</b>	The sampling rate of a MP3, WMA or MPEG-4 AAC file may not be compatible with the DVD player.	Check the sampling rate and bit rate of the MP3, WMA or MPEG-4 AAC file are compatible with the DVD player.	3
<b>Disc playback does not start.</b>	You may use a recordable media that is not finalized.	Finalize the recordable media.	—
	The disc label may not be facing up.	Place the disc in the disc tray with the label facing up.	—
	The disc may be defective.	Try to play back another disc. If the same problem does not occur, the disc you want to play back is defective.	—
	MP3/WMA/MPEG-4 AAC disc may not contain sufficient music tracks to be played back.	Check that your disc contains at least 5 MP3/WMA/MPEG-4 AAC music files.	—
	The sampling rate of a MP3, WMA or MPEG-4 AAC file may not be compatible with the DVD player.	Check the sampling rate and bit rate of an MP3, WMA or MPEG-4 AAC file are compatible with the DVD player.	3
<b>The message “HDMI ERROR” is displayed or there’s no picture on the HDMI TV.</b>	The wrong HDMI resolution is selected or an HDMI error has occurred.	Check the HDMI Resolution setting and correct as necessary.	41
		Reset the HDMI settings.	42
<b>The USB device cannot be recognized.</b>	The USB device is not connected correctly.	Connect the USB device correctly.	11
<b>The DVD player is not linked with the receiver.</b>	The system control cable is disconnected from the system connector jacks of the receiver and/or the DVD player.	Connect the system control cable properly to the system connector jacks of the receiver and the DVD player.	8

**■ USB**

**Note**

If a transmission error occurs but no status message is displayed on the front panel display of the receiver, check the connection between the DVD player and the USB device (Ⓢp.11).

<b>Status message</b>	<b>Cause</b>	<b>Remedy</b>	<b>See page</b>
NO USB	The USB device is not connected.	Connect a playable USB device.	11
OVER CURRENT	The USB device is either unplayable on this system or connected at an incorrect angle.	Disconnect the USB device. Change the input source to a device other than USB and back to USB. Then, correctly connect a playable USB device to the DVD player.	—

# SUPPORTED DISCS AND FORMATS

## Copy Control CDs

The DVD player conforms to the Audio CD standard. Operation and performance with discs that do not conform to this standard cannot be guaranteed.

## DualDisc

A DualDisc is a double-sided disc with a DVD layer for video on one side and a CD layer that can be played in a standard CD player on the other.

The DVD player can play the DVD side of DualDiscs. Since the CD layer does not conform to the Audio CD standard, some DualDiscs may not be played.

For more details about the DualDisc standard, please contact the disc's maker or reseller.

## Recordable disc compatibility

### ■ CD-R/RW

- The DVD player is compatible with CD-R/RW discs recorded with the following formats: Audio CD, VCD, SVCD, and ISO 9660 (CD-ROM).
- For ISO 9660 discs, use the ISO 9660 Level 1 or Level 2 CD-ROM file system, or the extended Joliet or Romeo file systems.
- Multisession discs are not supported.
- Unfinalized discs cannot be played. See your disc recorder owner's manual for details on finalizing.
- Some discs may not play, may produce noise, or may sound distorted. This is due to the disc and is not a malfunction.

### ■ DVD-R/RW/R DL

- The DVD player is compatible with DVD-R/RW and DVD-R DL (Dual Layer) discs recorded with the following formats: DVD-Video, VR mode (Video Recording mode), and UDF Bridge DVD-ROM.
- When playing content that's been edited on a DVD recorder (scenes deleted, etc.), the picture may disappear momentarily at the edit points. This is not a malfunction.
- Multisession discs are not supported.
- Unfinalized discs cannot be played. See your disc recorder owner's manual for details on finalizing.
- Some discs may not play, may produce noise, or may sound distorted. This is due to the disc and is not a malfunction.

### ■ DVD+R/RW/R DL

- The DVD player is compatible with DVD+R/RW and DVD+R DL (Dual Layer) discs recorded with the following formats: DVD-Video.
- When playing content that's been edited, playback may not follow the editing exactly.
- Multisession discs are not supported.
- Unfinalized discs cannot be played. See your disc recorder owner's manual for details on finalizing.
- Some discs may not play, may produce noise, or may sound distorted. This is due to the disc and is not a malfunction.

## Discs made on a computer

- Discs recorded on a computer may not be playable due to the settings of the disc burning software or the computer's configuration.
- Be careful to use the correct format when burning discs. Refer to your disc burning software owner's manual for details.
- Discs recorded with packet writing are not supported.

## MP3, WMA, and MPEG-4 AAC files

- The DVD player can play the following audio file formats: MP3 (MPEG-1 Audio Layer 3), WMA (Windows Media Audio), and MPEG-4 AAC.
- The DVD player can play MP3, WMA, and MPEG-4 AAC files stored on CD-R/RW discs and USB storage devices.
- The following sampling rates are supported: 32 kHz, 44.1 kHz, and 48 kHz.
- For MP3 and WMA files, we recommend bit rates higher than 128 kbps.
- For MPEG-4 AAC files, bit rates from 16 kbps to 320 kbps are supported.
- Variable bit rates (VBR) for MP3, WMA, and MPEG-4 AAC are not supported.
- WMA Lossless encoding is not supported.
- Files with DRM (Digital Rights Management) cannot be played.
- Only MP3, WMA, and MPEG-4 AAC files with an .mp3/.MP3, .wma/.WMA, or .m4a file extension, respectively, are recognized.
- Each disc may contain up to 299 folders, and each folder may contain a combination of up to 648 files and folders. However, depending the folder organization, not all folders and files may be recognized and playable.

## JPEG files

- The DVD player can play the following picture disc formats: Fuji Color CD, Kodak Picture CD. It can also play JPEG files stored on CD-R/RW discs and USB storage devices. Some picture discs may not be playable due to the way in which they were recorded, etc.
- Baseline JPEG files and Exif 2.2 JPEG files with a resolution of up to 3,072 x 2,048 are supported. (Exif, which stands for Exchangeable Image File, is the format used by digital cameras to store metadata.)
- Progressive JPEG files are not supported.
- Only JPEG files with a .jpg/.JPG file extension are recognized.
- Each disc may contain up to 299 folders, and each folder may contain a combination of up to 648 files and folders. However, depending on the folder organization, not all folders and files may be recognized and playable.

## About DivX<sup>®</sup>

DivX<sup>®</sup> media technology was developed by DivX, Inc. It uses compression to fit movies and video content onto CD and DVD discs at high quality. It supports interactive features such as menus, subtitles, and multiple language soundtracks. Like DVD-Video, individual DivX<sup>®</sup> files are referred to as *titles*.

The DVD player can play DivX<sup>®</sup> files stored on the recordable CD and DVD media listed in “Recordable disc compatibility” (Ⓔp.49). When naming DivX<sup>®</sup> files prior to burning to disc, be aware that DivX<sup>®</sup> files stored on a disc are played in alphabetical order.

- The DVD player is an official DivX<sup>®</sup> Ultra Certified product and can play all versions of DivX<sup>®</sup> video (including DivX<sup>®</sup> 6) with enhanced playback of DivX<sup>®</sup> media files and the DivX<sup>®</sup> Media Format.
- The DVD player can play DivX<sup>®</sup> files stored on CD-R/RW discs and CD-ROM discs, but not USB storage devices.
- Only DivX<sup>®</sup> encoded files with a .avi or .divx file extension are recognized.

## Using external subtitle files

DivX<sup>®</sup> movies use special files called *external subtitle files* for displaying subtitles. The font sets listed below are available for use with external subtitle files. Use the Subtitle Language setting on page 42 to select the font/language that matches the external subtitle file.

The DVD player supports the following language groups:

<b>Group 1</b>	Albanian (sq), Basque (eu), Catalan (ca), Danish (da), Dutch (nl), English (en), Faroese (fo), Finnish (fi), French (fr), German (de), Icelandic (is), Irish (ga), Italian (it), Norwegian (no), Portuguese (pt), Rhaeto-Romanic (rm), Scottish (gd), Spanish (es), Swedish (sv)
<b>Group 2</b>	Albanian (sq), Croatian (hr), Czech (cs), Hungarian (hu), Polish (pl), Romanian (ro), Slovak (sk), Slovenian (sl)
<b>Group 3</b>	Bulgarian (bg), Byelorussian (be), Macedonian (mk), Russian (ru), Serbian (sr), Ukrainian (uk)
<b>Group 4</b>	Hebrew (iw), Yiddish (ji)
<b>Group 5</b>	Turkish (tr)

### Notes

- Some external subtitle files may not display correctly, and some may not display at all.
- Only external subtitle files with a .srt, .sub, .ssa, or .smi file extension are recognized. (Note that these files are not displayed by Disc Navigator.)
- The file name of the external subtitle file must start with the file name of its associated movie file.
- A single movie may have up to 10 external subtitle files.

## About WMV

WMV, which stands for *Windows Media Video*, is a video compression technology developed by Microsoft Corporation. Video content can be encoded in WMV format by using the Windows Media Encoder.

- The DVD player supports WMV9 files that were encoded with the Windows Encoder 9 Series.
- The DVD player can play WMV files stored on CD-R/RW discs, but not USB storage devices.
- Only WMV9 files with a .wmv file extension are recognized.
- Video resolutions up to 720 x 480 or 720 x 576 are supported.
- The maximum average bit rate is about 2–3 Mbps. (The maximum bit rate depends on the encoding conditions.)
- Advanced Profile is not supported.
- Files with DRM (Digital Rights Management) cannot be played.

## About MPEG-4 AAC

AAC, which stands for *Advanced Audio Coding*, is the audio compression technology used for MPEG-2 and MPEG-4. The actual format of the data and file extension depends on the application used to make the AAC file.

- The DVD player can play AAC files made with iTunes that have a .m4a file extension.
- Files with DRM (Digital Rights Management) cannot be played, and files encoded with some version of iTunes may not play.

## About WMA

WMA, which stands for *Windows Media Audio*, is an audio compression technology developed by Microsoft Corporation. Audio content can be encoded in WMA format by using the Windows Media Player version 7.1.1, Windows Media Player for Windows XP, or Windows Media Player 9 Series.

- The DVD player can play WMA files.
- Use only applications that have been certified with Microsoft Corporation to encode WMA files. If you use an application that is not certified, the resultant files may not play properly.

## DVD-Video regions

The region number for the DVD player can be found on its rear panel. The DVD player can only play discs with the same region number or those marked *ALL*. If you attempt to play a DVD-Video disc with a different region number, the message “Incompatible disc region number, Can’t play disc” will be displayed.

## NOTES ABOUT HANDLING DISCS

- Always handle with care so that the playing surface is not scratched. Do not warp discs.

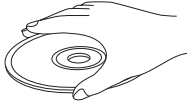

- To keep clean the playing surface, wipe with a clean, dry cloth. Do not use any type of disc cleaner, spray, or any other chemical-based liquid.
- Do not wipe with a circular motion; wipe straight outward from the center.

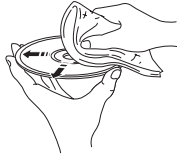

- Use a soft-tipped pen when writing on the label side of the disc.
- When a disc is not being used, remove it from this unit and store in an appropriate case.
- Do not expose discs to direct sunlight, high temperature or high humidity for a long time.

# GLOSSARY

## ■ AAC (Advanced Audio Coding)

An audio compression scheme defined as part of the MPEG-2/MPEG-4 standard. AAC supports up to 48 channels and generally achieves better sound quality than MP3 at the same bit rate.

## ■ Analog

Sound that has not been turned into numbers. Analog sound varies, while digital sound has specific numerical values. These terminals send audio through two channels, the left and right.

## ■ Aspect ratio

The ratio of vertical and horizontal sizes of a displayed image. The horizontal vs. vertical ratio of conventional TVs is 4:3, and that of wide-screens is 16:9.

## ■ Bit

Short for binary digit. Represents the smallest unit of information manipulated on a computer. In audio systems, the bit size determines resolution to digitize analog signals.

The larger the bit size, the larger the dynamic range (the ratio of maximum and minimum frequency level) and the finer the sounds. Generally, an audio CD is 16 bit and DVD audio is 24 bit.

## ■ Bit rate

The amount of data used to hold a given length of music; measured in kilobits per second, or kbps. Also, the speed at which you record. Generally, the higher the bit rate, or recording speed, the better the sound quality. However, higher bit rates use more space on a disc.

## ■ Component Video

Terminals for inputting or outputting a component video signal. Component video signal consists of three lines, the luminance signal (Y) and two color difference signals (PB/CB, PR/CR), which enable to provide high-quality video.

## ■ Disc menu

A screen display prepared for allowing selection of images, sounds, subtitles, multi-angles, etc. recorded on a DVD.

## ■ DivX<sup>®</sup>

DivX<sup>®</sup> is a popular media technology created by DivX, Inc. DivX<sup>®</sup> media files contain highly compressed video with high visual quality that maintains a relatively small file size. DivX<sup>®</sup> files can also include advanced media features like menus, subtitles, and alternate audio tracks. Many DivX<sup>®</sup> media files are available for download online, and you can create your own using your personal content and easy-to-use tools from DivX.com.

## ■ DivX<sup>®</sup> Ultra

DivX<sup>®</sup> Ultra Certified products provide enhanced playback of advanced media features supported by the DivX<sup>®</sup> Media Format. Key features include interactive video menus, subtitles, alternate audio tracks, video tags, and chapter points.

## ■ DMF (DivX<sup>®</sup> Media Format)

The DivX<sup>®</sup> Media Format supports advanced media features, adding controls for an interactive media experience: interactive video menus, chapter points, multi-language subtitles, and alternate audio tracks.

## ■ Dolby Digital

Digital surround sound system which is developed by Dolby Laboratories provides completely independent multi-channel audio. With 3 front channels (left, center, and right) and 2 surround stereo channels, Dolby Digital provides five full-range audio channels. With an additional channel especially for bass effects (called LFE, or low frequency effect), the system has a total of 5.1-channels (LFE is counted as 0.1 channel). By using 2-channel stereo for the surround speakers, more accurate moving sound effects and surround sound environment are possible than with Dolby Surround.

## ■ Dolby Pro Logic II

It is an improved matrix decoding technology that provides better spatiality and directionality on Dolby Surround programmed material; provides a convincing three-dimensional soundfield on conventional stereo music recordings; and is ideally suited to bring the surround experience to automotive sound. While conventional surround programming is fully compatible with Dolby Pro Logic II decoders, soundtracks will be able to be encoded specifically to take full advantage of Pro Logic II playback, including separate left and right surround channels. (Such material is also compatible with conventional Pro Logic decoders).

## ■ DTS (Digital Theater Systems)

Digital surround sound system developed by Digital Theater Systems, Inc., which provides 5.1 channel audio (max). With an abundance of audio data, it is able to provide authentic-sounding effects.

## ■ HDMI

HDMI (High-Definition Multimedia Interface) is the first industry-supported, uncompressed, all-digital audio/video interface. Providing an interface between any source (such as a set-top box or AV controller) and an audio/video monitor (such as a digital television), HDMI supports standard, enhanced or high-definition video as well as multi-channel digital audio using a single cable. HDMI transmits all ATSC (Advanced Television Systems Committee) HDTV standards and supports 8-channel digital audio, with bandwidth to spare to accommodate future enhancements and requirements.

When used in combination with HDCP (High-bandwidth Digital Content Protection), HDMI provides a secure audio/video interface that meets the security requirements of content providers and system operators.

For further information on HDMI, visit the HDMI website at “[www.hdmi.org](http://www.hdmi.org)”.

## ■ Interlace

The most common type of scanning used in televisions. It divides a screen into even and odd numbered fields for scanning, and then builds an image by combining them into one image (frame).

## ■ JPEG (Joint Photographic Experts Group)

A standardized image compression system proposed by the Joint Photographic Experts Group. It can reduce image data sizes to 1 to 10% of their original sizes, and works on digital photographs effectively.

## ■ MP3 (MPEG Audio Layer-3)

An audio file compression technology. It can reduce audio data sizes to about 10% of their original sizes while maintaining CD-level audio quality.

## ■ MPEG (Moving Pictures Experts Group)

International standard for digital video and audio compression generated by ISO (International Organization for Standardization) and IEC (International Electrotechnical Commission).

Includes MPEG-1, MPEG-2, and MPEG-4. MPEG-1 offers VHS level video quality and is often used on video CDs. MPEG-2 offers S-VHS level video quality and is often used on DVDs.

## ■ Parental lock

Limits Disc play according to the age of the users or the limitation level in each country. The limitation varies from disc to disc; when it is activated, playback will be prohibited if the software’s level is higher than the user-set level.

## ■ Playback control (PBC)

An on-screen menu recorded on a Video CD or Super Video CD that enables interactive playback and searching.

## ■ Progressive Scan

A method of displaying all scanning lines in a frame at once, reducing flicker noticeable on a larger screen and creating a sharp and smooth image.

## ■ Region code

Many DVD discs include a region code so that the copyright owner can control DVD software distribution only to regions where they are ready to distribute. There are six regions codes, which restrict a DVD player to playing a DVD disc with the same region code.

## ■ Surround

A controller for creating realistic three-dimensional sound fields full of realism by arranging multiple speakers around the listener.

## ■ VR format (Video Recording format)

A DVD video recording format, which allows editing DVD video data recorded onto a disc. You need a VR format compatible player for playback.



# SPECIFICATIONS

## ■ R-840

### AMPLIFIER SECTION

- Minimum RMS output power per channel (6  $\Omega$ , 1 kHz, 10 % THD) ..... 65 W + 65 W
- Input sensitivity/Impedance  
PLAYER, etc. .... 200 mV/47 k $\Omega$
- Frequency response  
PLAYER, etc. .... 20 Hz to 20 kHz  $\pm$  0.5 dB
- Total harmonic distortion  
PLAYER, etc. (30 W/6  $\Omega$ ) ..... 0.04 % or less
- Signal to noise ratio (IHF-A network)  
PLAYER (200 mV, Input shorted) ..... 100 dB or more

### TUNER SECTION

- DAB ..... 174 to 240 MHz (Band III)
- FM ..... 87.50 to 108.00 MHz

### GENERAL

- Power supply ..... AC 240 V, 50 Hz
- Power consumption ..... 115 W
- Dimensions (W  $\times$  H  $\times$  D) ..... 215  $\times$  110  $\times$  348 mm  
(8 1/2  $\times$  4 3/8  $\times$  13 3/4 in)
- Weight ..... 5.7 kg (12.6 lbs)
- Standby power consumption ..... less than 0.3 W

## ■ DVD-840

### DVD section

- AUDIO OUT
  - Output level (1 kHz, 0 dB) ..... 2 V ( $\pm$  0.3)
  - Signal to noise ratio ..... more than 100 dB
  - Dynamic range (48 kHz, 24 bit) ..... more than 100 dB
  - Total harmonic distortion ..... less than 0.003 %
  - Frequency response ..... 10 Hz–22 kHz
- Video output
  - Composite ..... 1 Vp-p/75  $\Omega$
  - Component ..... 1 Vp-p/75  $\Omega$  (Y)  
0.7 Vp-p/75  $\Omega$  (PB, PR)

### Audio format

- Dolby Digital, DTS, MPEG decoding
- PCM DATA: 16 bit
- LPCM DATA: 20/24 bit  
Fs: 44.1, 48 kHz, 88.2/96 kHz downmix support

### General

- Power supply ..... AC 240 V, 50 Hz
- Power consumption ..... 12 W
- Standby power consumption ..... less than 0.5 W
- Dimensions (W  $\times$  H  $\times$  D) ..... 215  $\times$  108  $\times$  318 mm  
(8 1/2  $\times$  4 1/4  $\times$  12 1/2 in.)
- Weight ..... 2.8 kg  
(6.2 lbs.)

Specifications are subject to change without notice.

MPEG Layer-3 audio decoding technology licensed from Fraunhofer IIS and Thomson Multimedia.

**iPod™**

“iPod” is a trademark of Apple Inc., registered in the U.S. and other countries.

“Made for iPod” means that an electronic accessory has been designed to connect specifically to iPod and has been certified by the developer to meet Apple performance standards.

Apple is not responsible for the operation of this device or its compliance with safety and regulatory standards.



Digital Audio Broadcasting

This unit supports DAB tuning.



DivX, DivX Ultra Certified, and associated logos are trademarks of DivX, Inc. and are used under license.



Manufactured under license from Dolby Laboratories. Dolby and the double-D symbol are trademarks of Dolby Laboratories.



Manufactured under license under U.S. Patent #'s: 5,451,942; 5,956,674; 5,974,380; 5,978,762; 6,487,535 & other U.S. and worldwide patents issued & pending. DTS and DTS 2.0 + Digital Out are registered trademarks and the DTS logos and Symbol are trademarks of DTS, Inc. © 1996-2007 DTS, Inc. All Rights Reserved.



“HDMI”, the “HDMI” logo, and “High-Definition Multimedia Interface” are trademarks or registered trademarks of HDMI Licensing LLC.

MPEG Layer-3 audio decoding technology licensed from Fraunhofer IIS and Thomson multimedia.



Windows Media is either a registered trademark or trademark of Microsoft Corporation in the United States and/or other countries.

**Resetting the DVD player**

You can reset the DVD player to its factory defaults.

- 1** Set the DVD player to standby.



---

- 2** While holding down  on the DVD player’s front panel, press .



---

- 3** Release  when “DVD — NO REQ.” is displayed on the front panel display.

---

- 4** Press  /  repeatedly to select “DVD INIT”.  
If you change your mind at this point, select “DVD — NO REQ.” instead.

---

- 5** Press .  
The DVD player is reset to its factory defaults and goes on standby. Press  again to turn the DVD player back on.  
The TV Screen, HDMI Resolution, and other settings will be set to their factory defaults. The HDMI Audio setting will be set to off.

# LANGUAGE, COUNTRY, AND REGION LISTS

## Language list

### ■ Language (abbreviation), code number

Japanese (ja), 1001	Bhutani (dz), 0426	Kirghiz (ky), 1125	Sinhalese (si), 1909
English (en), 0514	Esperanto (eo), 0515	Latin (la), 1201	Slovak (sk), 1911
French (fr), 0618	Estonian (et), 0520	Lingala (ln), 1214	Slovenian (sl), 1912
German (de), 0405	Basque (eu), 0521	Laothian (lo), 1215	Samoan (sm), 1913
Italian (it), 0920	Persian (fa), 0601	Lithuanian (lt), 1220	Shona (sn), 1914
Spanish (es), 0519	Finnish (fi), 0609	Latvian (lv), 1222	Somali (so), 1915
Chinese (zh), 2608	Fiji (fj), 0610	Malagasy (mg), 1307	Albanian (sq), 1917
Dutch (nl), 1412	Faroese (fo), 0615	Maori (mi), 1309	Serbian (sr), 1918
Portuguese (pt), 1620	Frisian (fy), 0625	Macedonian (mk), 1311	Siswati (ss), 1919
Swedish (sv), 1922	Irish (ga), 0701	Malayalam (ml), 1312	Sesotho (st), 1920
Russian (ru), 1821	Scots-Gaelic (gd), 0704	Mongolian (mn), 1314	Sundanese (su), 1921
Korean (ko), 1115	Galician (gl), 0712	Moldavian (mo), 1315	Swahili (sw), 1923
Greek (el), 0512	Guarani (gn), 0714	Marathi (mr), 1318	Tamil (ta), 2001
Afar (aa), 0101	Gujarati (gu), 0721	Malay (ms), 1319	Telugu (te), 2005
Abkhazian (ab), 0102	Hausa (ha), 0801	Maltese (mt), 1320	Tajik (tg), 2007
Afrikaans (af), 0106	Hindi (hi), 0809	Burmese (my), 1325	Thai (th), 2008
Amharic (am), 0113	Croatian (hr), 0818	Nauru (na), 1401	Tigrinya (ti), 2009
Arabic (ar), 0118	Hungarian (hu), 0821	Nepali (ne), 1405	Turkmen (tk), 2011
Assamese (as), 0119	Armenian (hy), 0825	Norwegian (no), 1415	Tagalog (tl), 2012
Aymara (ay), 0125	Interlingua (ia), 0901	Occitan (oc), 1503	Setswana (tn), 2014
Azerbaijani (az), 0126	Interlingue (ie), 0905	Oromo (om), 1513	Tonga (to), 2015
Bashkir (ba), 0201	Inupiak (ik), 0911	Oriya (or), 1518	Turkish (tr), 2018
Byelorussian (be), 0205	Indonesian (in), 0914	Panjabi (pa), 1601	Tsonga (ts), 2019
Bulgarian (bg), 0207	Icelandic (is), 0919	Polish (pl), 1612	Tatar (tt), 2020
Bihari (bh), 0208	Hebrew (iw), 0923	Pashto, Pushto (ps), 1619	Twi (tw), 2023
Bislama (bi), 0209	Yiddish (ji), 1009	Quechua (qu), 1721	Ukrainian (uk), 2111
Bengali (bn), 0214	Javanese (jw), 1023	Rhaeto-Romance (rm), 1813	Urdu (ur), 2118
Tibetan (bo), 0215	Georgian (ka), 1101	Kirundi (rn), 1814	Uzbek (uz), 2126
Breton (br), 0218	Kazakh (kk), 1111	Romanian (ro), 1815	Vietnamese (vi), 2209
Catalan (ca), 0301	Greenlandic (kl), 1112	Kinyarwanda (rw), 1823	Volapük (vo), 2215
Corsican (co), 0315	Cambodian (km), 1113	Sanskrit (sa), 1901	Volof (wo), 2315
Czech (cs), 0319	Kannada (kn), 1114	Sindhi (sd), 1904	Xhosa (xh), 2408
Welsh (cy), 0325	Kashmiri (ks), 1119	Sangho (sg), 1907	Yoruba (yo), 2515
Danish (da), 0401	Kurdish (ku), 1121	Serbo-Croatian (sh), 1908	Zulu (zu), 2621

## Country and region list

### ■ Language, code number, abbreviation

Argentina, 0118, ar	Finland, 0609, fi	Malaysia, 1325, my	Singapore, 1907, sg
Australia, 0121, au	France, 0618, fr	Mexico, 1324, mx	Spain, 0519, es
Austria, 0120, at	Germany, 0405, de	Netherlands, 1412, nl	Sweden, 1905, se
Belgium, 0205, be	Hong Kong, 0811, hk	New Zealand, 1426, nz	Switzerland, 0308, ch
Brazil, 0218, br	India, 0914, in	Norway, 1415, no	Taiwan, 2023, tw
Canada, 0301, ca	Indonesia, 0904, id	Pakistan, 1611, pk	Thailand, 2008, th
Chile, 0312, cl	Italy, 0920, it	Philippines, 1608, ph	United Kingdom, 0702, gb
China, 0314, cn	Japan, 1016, jp	Portugal, 1620, pt	USA, 2119, us
Denmark, 0411, dk	Korea, Republic of, 1118, kr	Russian Federation, 1821, ru	

**CAUTION**

Use of controls or adjustments or performance of procedures other than those specified herein may result in hazardous radiation exposure.

**CAUTION - VISIBLE AND / OR INVISIBLE LASER RADIATION WHEN OPEN.  
AVOID EXPOSURE TO BEAM.**

**DVD-840**

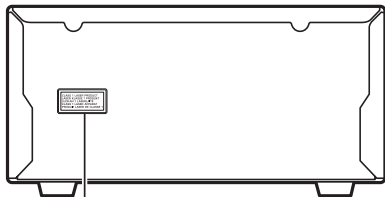

**CLASS 1 LASER PRODUCT  
LASER KLASSE 1 PRODUKT  
LUOKAN 1 LASERLAITE  
KLASS 1 LASER APPARAT  
PRODUIT LASER DE CLASSE 1**

**CAUTION - CLASS 3B VISIBLE AND INVISIBLE LASER RADIATION WHEN OPEN.  
AVOID EXPOSURE TO BEAM.**  
VARNING - KLASS 3B SYNLIG OCH OSYNLIG LASERSTRÅLNING  
NÄR DENNA DEL ÄR ÖPPNAD. STRÅLEN ÄR FARLIG.  
VARO ! AVATTAESSA OLET ALTTIINA LUOKAN 3B NÄKYVÄLLE JA  
NÄKYMÄTÖMÄLLE LASERSÄTELYLLE, ÄLÄ KATSO SÄTEESEEN.  
VARNING - KLASS 3B SYNLIG OCH OSYNLIG LASERSTRÅLNING  
NÄR DENNA DEL ÄR ÖPPNAD. BETRÄKTA EJ STRÅLEN.  
VORSICHT ! SICHTBARE UND UNSICHTBARE LASERSTRÄHLUNG KLASSE 3B  
WENN ABDECKUNG GEÖFFNET. NICHT DEN STRAHL AUSSETZEN.  
ATTENTION - RADIATION VISIBLE ET INVISIBLE CLASSE 3B LORSQUE L'APPAREIL  
EST OUVERT. ÉVITEZ TOUTE EXPOSITION AU FAISCEAU.

**DVD-840**

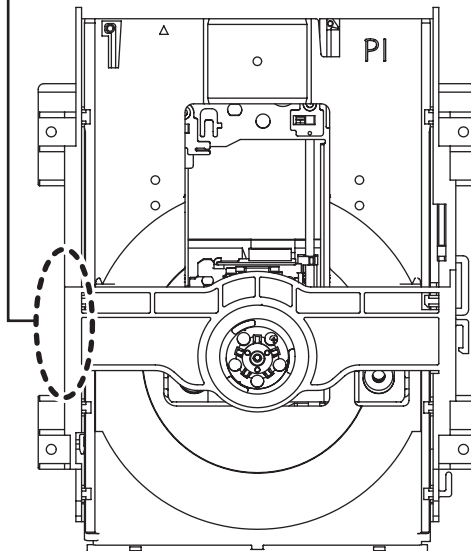

YAMAHA CORPORATION

Printed in Malaysia © WS51490