

YAMAHA POWERED LOUDSPEAKERS

POWERED LOUDSPEAKERS

DZR SERIES

POWERED SUBWOOFERS

DXS XLF SERIES

POWERED LOUDSPEAKERS

DXR mkII SERIES

POWERED SUBWOOFERS

DXS SERIES

POWERED LOUDSPEAKERS

DHR SERIES

POWERED LOUDSPEAKERS

DBR SERIES

POWERED SPEAKER

DXL1K



D SERIES LINEUP

A LINEUP THAT SUPPORTS A VARIETY OF APPLICATIONS.

POWERED LOUDSPEAKERS
DXR mkII SERIES
 DXR15mkII DXR12mkII DXR10mkII DXR8mkII

Louder, Lighter, Legendary

Power ●●●●●
 Portability ●●●●●
 Function ●●●●●



POWERED LOUDSPEAKERS
DZR SERIES
 DZR315/315-D DZR15/15-D DZR12/12-D DZR10/10-D

Power and Performance. Integrated.

Power ●●●●●
 Portability ●●●●●
 Function ●●●●●



POWERED LOUDSPEAKERS
DBR SERIES
 DBR15 DBR12 DBR10

Power to Play

Power ●●●●●
 Portability ●●●●●
 Function ●●●●●



POWERED SUBWOOFERS
DXS XLF SERIES
 DXS18XLF/DXS18XLF-D DXS15XLF/DXS15XLF-D

How Low Can You Go?

Power ●●●●●
 Portability ●●●●●
 Function ●●●●●



POWERED SUBWOOFERS
DXS SERIES
 DXS18 DXS15mkII DXS12mkII

Serious. Bass. Performance.

Power ●●●●●
 Portability ●●●●●
 Function ●●●●●



POWERED LOUDSPEAKERS
DHR SERIES
 DHR15 DHR12 DHR10 DHR15M DHR12M

Performance. Optimized.

Power ●●●●●
 Portability ●●●●●
 Function ●●●●●



PLASTIC CABINET

PLYWOOD CABINET

MORE POWERFUL, MORE FUNCTIONAL

D SERIES LINEUP

THE POWER OF “D”

Our development team took full advantage of a number of advanced digital technologies, both new and refined, based on Yamaha's extensive experience accumulated over many long years of developing professional audio equipment. Everything from the detailed management of crossover, EQ and time alignment to the limiter settings, protection functions and precise dynamic control of the sound, was subjected to endless simulation, in-house and field testing to ensure that these speakers produce the highest level of sound quality at the highest output levels possible. Combined with Yamaha's advanced analog signal processing and acoustic technologies, the Power of “D” delivers ultimate performance.

Ultra-Precise DSP Processing for High Definition Sound

All full-range models feature Yamaha's proprietary FIR-X tuning™ utilizing linear phase FIR* filters for the crossover. FIR-X tuning™ simultaneously optimizes frequency and phase response while adjusting the time alignment between the HF and LF transducers. This creates a very smooth response around the crossover point, providing much better clarity and imaging than what is possible with conventional crossovers.

All signals are precisely processed by a high-performance processor for high-definition sound quality. All full-range models and DXS subwoofers employ high-precision 24bit discrete A/D and D/A converters with superior S/N ratio and dynamic range.

*Finite impulse response

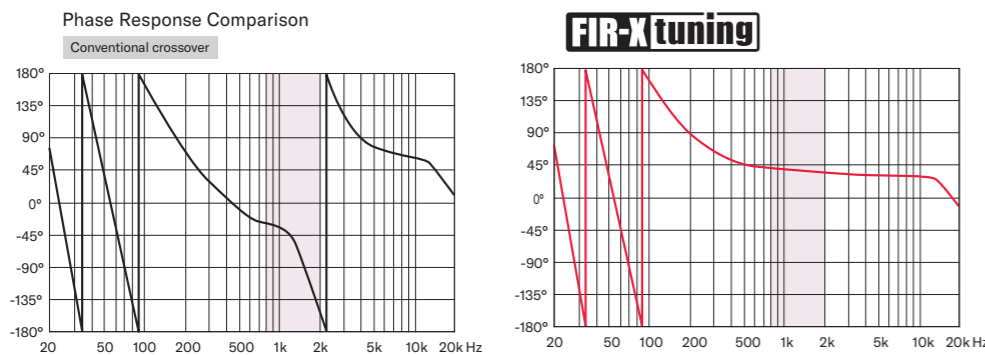
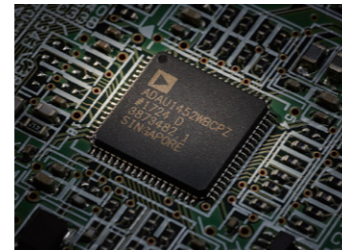

Intelligent Dynamic Control for Consistent Clarity at Any Output Level

D-CONTOUR is an intelligent multi-band dynamics processor that gives you powerful and consistent sound throughout all output levels. By constantly monitoring the output of multiple frequency bands, DZR, DXR, DHR and DBR speakers calculate and dynamically apply the optimum adjustments for each, maintaining outstanding clarity and musicality from low all the way to maximum SPL levels.

With the DXR and DBR Series, D-CONTOUR provides a more detailed tuning of your sound with two different settings: FOH/MAIN mode or MONITOR mode. FOH/MAIN mode boosts low-frequency to compensate for low-end that is typically missing when speakers are used in suspended applications or mounted on a speaker stand. MONITOR mode is completely optimized for floor monitor application by intelligently taming down the low-frequency that builds up due to floor reflection to give you stunning clarity or monitoring your sound. Both of these presets were perfected by performing countless listening tests with skilled sound engineers, delivering consistent sound with minimal distortion at any output level.

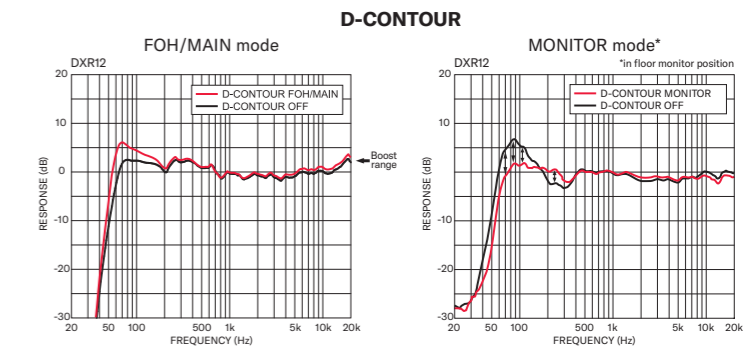

Extensive DSP Protection Functions for Maximum Output

During the development of the DZR, DXR, DHR, DBR and DXS Series, we measured and tested the durability of each transducer and the overall amp output through numerous indoor and outdoor listening tests. Based on the results, we were able to set the optimal limiter point for each model using precise DSP control. In addition to the optimized limiting our powered loudspeakers employ many of the same protection functions used in our top-class TXn Series professional power amplifiers. A microprocessor and high-power DSP monitor the status of the power supply, power amplifiers, transducers and ongoing signals, to protect all aspects of each component. As a result, these speakers can perform to their full potential while ensuring reliable operation in even the most severe conditions.

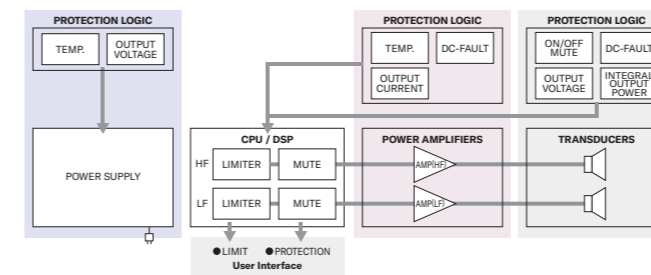

AMPLIFIER AND SPEAKER TECHNOLOGIES

Yamaha loudspeakers don't owe their superb audio performance to cutting-edge DSP technology alone. Only in combination with the very best amplifier units and Yamaha's accrued knowledge of acoustic technologies can these speakers operate at such a consistent, reliable level of performance.

High-Efficiency Class-D Amplifier to deliver the Best-in-class Power

All full-range models feature Yamaha's proprietary FIR-X tuning™ utilizing linear phase FIR* filters for the crossover. FIR-X tuning™ simultaneously optimizes frequency and phase response while adjusting the time alignment between the HF and LF transducers. This creates a very smooth response around the crossover point, providing much better clarity and imaging than what is possible with conventional crossovers.

All signals are precisely processed by a high-performance processor for high-definition sound quality. All full-range models and DXS subwoofers employ high-precision 24bit discrete A/D and D/A converters with superior S/N ratio and dynamic range

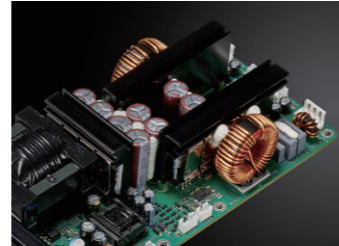

Custom Designed Transducers for High-Definition Sound

Choosing the right transducer can have a considerable impact on the overall sound of a speaker and it's not a task our team took lightly. All DZR, DXR, DHR, DBR and DXS transducers were meticulously selected and thoroughly customized in order to deliver the best possible performance. The detailed characteristics and behavior of each transducer were fully analyzed and evaluated with sophisticated computer simulations in order to help realize their full performance potential. The high power output woofers deliver minimal distortion and defined, deep bass, while the precision compression drivers produce accurate midrange and high frequencies up to 20kHz.



Rugged Enclosure Design for Optimal Acoustic Performance

The durability, materials, and shape of the enclosure have a profound effect on the overall sound of the speaker. Even if high-quality amplifiers and transducers are used, a lack of durability, or errant design of the enclosure will create unwanted resonance and noise. By drawing from Yamaha's extensive history of developing loudspeakers and studio monitors, we carefully simulated and designed highly durable cabinets that eliminate unwanted resonance, and help deliver high-definition sound regardless of the output levels.



Wide Dispersion Constant Directivity Horn for Consistent Sound Dispersal

The extremely accurate constant directivity horn was designed with the goal of minimizing the radiation pattern deterioration in oblique directions that other, more conventional horns are prone to. This can help to achieve a more ideal coverage area without irregularities. With Yamaha's wide dispersion constant directivity horn, sound expands in a more rectangular pattern, evenly dispersing wide-frequency sound to the outer-most edges of the coverage area.

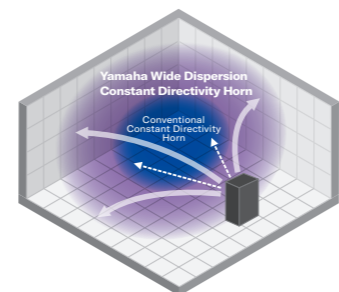

POWER AND PERFORMANCE. INTEGRATED.

The culmination of all Yamaha's accrued sound reinforcement, acoustics, and signal processing technology expertise—particularly with the introduction of our Dante-enabled models— DZR represents Yamaha's first fully-integrated, smart/editable speaker range of professional, powered loudspeakers.



High power 2000W Class-D amplification

The all new, highly efficient Class-D amplification module produces best-in-class 2000W of power and impressive 143dB SPL. A universal switching mode power supply with PFC maximizes the power output while ensuring stable and worry-free operation. All the amplifiers were selected and optimized to match the full-range DZR's high, mid (only for DZR315), and low frequency transducers, while separate, customized amps were developed for the DXS-XLF subwoofers as well.

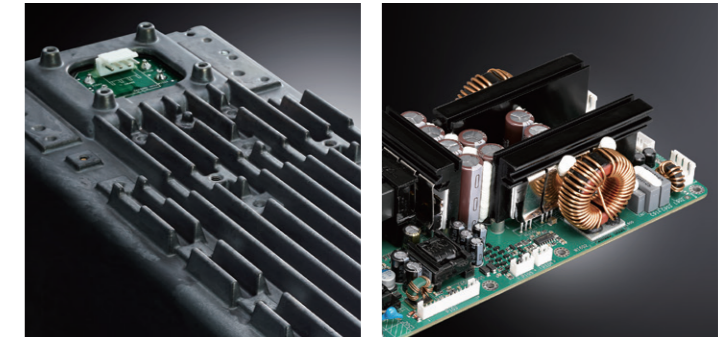

Utilities for safe and secure operation

DZR Series make it fast and easy to configure panel settings and transfer data via USB, and also feature a panel locking function to keep your settings safe. Users can even export information such as internal device and log data to USB for rapid troubleshooting should difficulties arise.



U Brackets for vertical or horizontal mounting

DZR Series loudspeakers offer plenty of rigging points, allowing for rigged application with U Bracket and standard eyebolts*. Please refer to the specifications for details.

*Eyebolts not included.

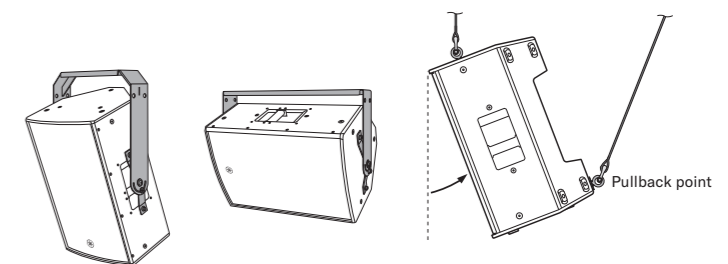

*You can use the U-bracket in combination with optional brackets sold separately. For more information, visit the following Yamaha Pro Audio website. <https://www.yamahaproaudio.com/>

| | Power ¹ | Maximum SPL ² | Frequency Range (-10dB) | LF | MF | HF | Coverage Angle |
|---------------------|--------------------|--------------------------|-------------------------|-----------------|---------|------------------|-------------------------|
| DZR315/315-D | 2000W | 143dB SPL | 31Hz - 20kHz | 15" Cone, 3" VC | 8" Cone | 2" VC, 1" Throat | H75° x V50° |
| DZR15/15-D | 2000W | 139dB SPL | 34Hz - 20kHz | 15" Cone, 3" VC | - | 2" VC, 1" Throat | H90° x V50° (Rotatable) |
| DZR12/12-D | 2000W | 139dB SPL | 39Hz - 20kHz | 12" Cone, 3" VC | - | 2" VC, 1" Throat | H90° x V60° (Rotatable) |
| DZR10/10-D | 2000W | 137dB SPL | 44Hz - 20kHz | 10" Cone, 3" VC | - | 2" VC, 1" Throat | H90° x V60° (Rotatable) |

¹ Dynamic power ² Measured Maximum SPL (peak)

Smart design for professional functionality

DZR15, DZR12 and DZR10 speakers feature a rotatable horn to allow vertical or horizontal mounting to further adapt to the acoustic dimensions of a venue. The coverage angle of the DZR15 is 90x50° and the DZR12 and DZR10 have 90x60° dispersion from a vertical position. The constant directivity horns were designed with the goal of providing smooth, level coverage across the intended coverage area, minimizing roll-off that is common in conventional horn designs.

Our newly developed proprietary LF transducers use large 3" voice coils, cast aluminum frames, and a very strong, lightweight neodymium magnet to handle high power and provide powerful low frequency response despite the lightweight construction. The performance is tightly controlled, particularly in the mid-bass and vocal range, assuring overall response is powerful and distortion-free even at the highest outputs.

The HF transducers are comprised of a 2" voice coil and 1" throat compression driver, a titanium diaphragm and Neodymium magnet housed in a durable heat-resistant aluminum cast frame. The MF transducer for the 3-way DZR315 models feature an 8" Cone and 1.5" voice coil providing better efficiency and super-low distortion for the low-mid frequencies, and contributing to the extraordinarily high 143dB maximum SPL and the clarity of the sound.



The cabinets are constructed from a high grade 15mm thick plywood then painted with an extremely durable, military grade Polyurea coating. The enclosures of the full-range speakers also feature butterfly joints for added strength and cabinet vibration reduction, as well as a wide, flare-shaped port that helps to minimize port noise even at very high output levels. The enclosure design for the DZR15, DZR12 and each of their Dante models, enables mirror-mode monitor placement that produces a symmetrical sound field for the performer, creating a larger, more defined "sweet spot" than conventional monitoring configurations (DZR10/DZR10-D are asymmetric). Used in either a balanced dual-mono configuration or a stereo monitor mix setup, mirror-mode floor monitoring can enhance your playing and performance considerably.

| | Coverage Angle | | Rotatable | Monitor Angle | Mirroring |
|--------------|----------------|-----|-----------|---------------|-----------|
| | H | V | | | |
| DZR315/315-D | 75° | 50° | - | - | - |
| DZR15/15-D | 90° | 50° | | 50° | • |
| DZR12/12-D | 90° | 50° | | 50° | • |
| DZR10/10-D | 90° | 50° | | 50° | - |



The first Dante-equipped professional SR loudspeakers

All DZR speakers and DXS-XLF subwoofers come in Dante-equipped "D" models enabling smart system integration with Yamaha consoles and other Dante devices via the Dante I/O (2in/2out) which also features SRC (sample rate conversion) allowing 48kHz device compatibility. Patching is simplified considerably with Yamaha CL/QL digital mixing consoles from the I/O device display, while TF console users can select Quick Config for surprisingly fast, easy set up and operation of a sophisticated sound reinforcement system. Combining the Analog I/O with Dante I/O, opens up flexible routing and system configuration options, while the Dante break-IN and break-OUT functions add even more flexibility by acting as a simple I/O box. What's more, Yamaha's customizable control panel software "ProVisionare Control" for windows and "ProVisionare Touch" for iPad are also Dante compatible, adding more simple remote management of your sound reinforcement system.



Full Dante Connection

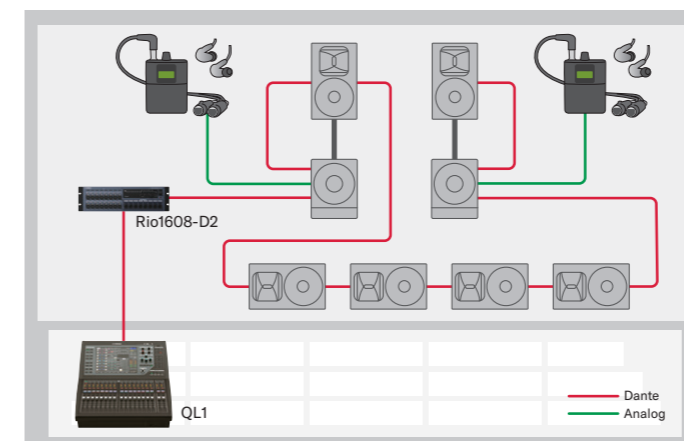

Mixed Connection

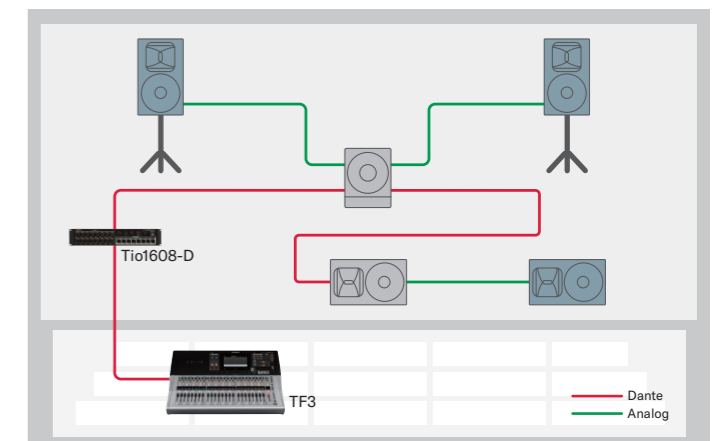

POWERED SUBWOOFERS

DXS XLF SERIES

DXS18XLF/18XLF-D DXS15XLF/15XLF-D

HOW LOW CAN YOU GO?

Not for the faint of heart, the newest DXS-XLF go deeper than any model before, with an extended low frequency of 30Hz— perfect for professional touring musicians, DJ's, and sound engineers who need that extra-low, thundering bottom end that you just can't get from other subwoofers in this class. Flexible DSP and a bass-reflex cabinet design with a wide, flared port ensure your lower frequencies maintain outstanding clarity and musicality even when the volume is cranked.



DXS XLF SERIES

Powerful DSP for flexible control

Like the full-range DZR models, the DXS-XLF subwoofers are also driven by 96kHz high power DSP processors and utilize dynamic EQ. Onboard D-XSUB LF processing gives you total management of your lower frequencies with NORMAL mode set for ideally balanced low-frequency response, while BOOST mode provides a tighter and more focused bass with some extra punch. XTENDED LF mode drops the low-end frequencies down even further for thunderous bottom end that delivers a low frequency extension unheard of from a cabinet of this size. Usually the higher the output, the more difficult it is to manage low frequency energy directivity, and significant stage-side sound pressure levels can seriously sabotage your monitoring, but with DXS-XLF setups consisting of two or more subwoofers, selecting the Cardioid Mode effectively decreases the sound pressure on stage while increasing the bottom-end output directed towards the audience, resulting in a much cleaner stage monitoring environment. Without a doubt, your DZR full-range system will reach new performance heights when used with the pronounced, powerful lows of DXS-XLF powered subwoofers.

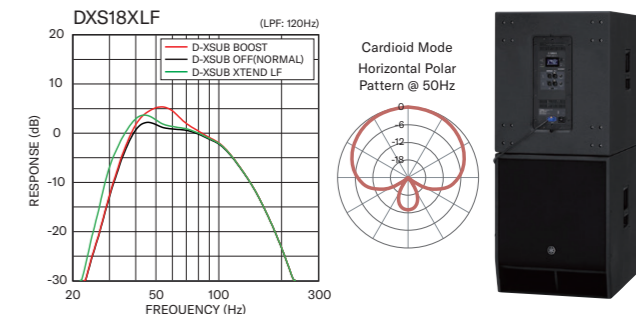

Dante-equipped for sophisticated capability with simple connectivity

Just like the DZR Series, each DXS-XLF model comes in a Dante-equipped "D" version enabling smart system integration with Yamaha consoles and other Dante devices via the Dante I/O (2in/2out) which also features SRC (sample rate conversion) allowing 48kHz device compatibility. Patching is simplified considerably with Yamaha CL/QL digital mixing consoles from the I/O device display, while TF console users can select Quick Config for surprisingly fast, easy set up and operation of a sophisticated sound reinforcement system. Combining the Analog I/O with Dante I/O, opens up countless routing and system configuration options, while the Dante break-IN and break-OUT function can add even more flexibility by acting as a simple I/O box. What's more, Yamaha's customizable control panel software "ProVisionare Control" for windows and "ProVisionare Touch" for iPad are also Dante compatible, adding more simple remote management of your sound reinforcement system.



Acoustics and utility

New Yamaha proprietary transducers with a durable die-cast aluminum frame and 4" voice coil are crucial to achieving such impressive low frequency response, even at the highest output levels. A dual damper also helps to realize extraordinarily high linearity of the low frequencies by mitigating unwanted vibration during extreme output levels.



Durable, portable, and road-ready

DXS-XLF enclosure exteriors feature a durable Polyurea coating with extremely high damage resistance to protect the cabinet from scratches, bumps, or severe weather conditions, maintaining a professional appearance for years to come. Additionally, the new, easy-to-grip aluminum handle, optional SPW1 wheel kit, and SPCVR speaker covers provide additional safety, portability, and peace of mind when you're on the road.



| | Power ¹ | Maximum SPL ² | Frequency Range (-10dB) | LF |
|-------------------------|--------------------|--------------------------|-------------------------|-----------------|
| DXS18XLF/18XLF-D | 1600W | 136dB SPL | 30Hz - 150kHz | 18" Cone, 4" VC |
| DXS15XLF/15XLF-D | 1600W | 136dB SPL | 33Hz - 150kHz | 15" Cone, 4" VC |

¹ Dynamic power ² Measured Maximum SPL (peak)

LOUDER, LIGHTER, LEGENDARY

Since its inception, the DXR Series has long signified a confluence of raw power and technological innovation that reliably harnesses and delivers impressively high output with superior quality and clarity. The DXR mkII Series powered loudspeakers are the newly upgraded models of the series that add even more SPL and feature a larger, yet much lighter 1.75" Neodymium HF compression driver for extremely clear voice reproduction and musicality. Once again our team worked in tight collaboration with touring loudspeaker specialists NEXO, adding crucial insight and expertise that led to design improvements based on the ever-evolving demands of sound reinforcement professionals.

Whether for fixed applications or mobile live performances - whatever direction you want to take your sound - the DXR mkII Series is up to the task, combining raw power with our own proprietary advanced DSP functions for all the reliability and outstanding clarity you've come to expect from the DXR Series... only MORE.



High-Efficiency 1100W Class-D Amplifiers

The DXR's compact but highly efficient Class-D amplifier also delivers class-leading sound output with 1100W of power, producing an impressive SPL of up to 133dB, with consistent precision and dynamic performance. The powerful amplifier employs a switching-mode power supply that guarantees consistent performance worldwide.



Custom Designed Transducers

The high power output woofers come equipped with a 2.5" voice coil (2" for DXR8mkII and DXR10mkII) delivering minimal distortion and clear, prominent bass; while the 1.75" compression drivers produce accurate midrange frequencies and highs up to 20kHz.



Durable, Compact ABS Enclosures

DXRmkII Series speaker cabinets are moulded in rugged, non-resonant ABS enclosures, designed to dampen down vibrations caused by high output levels, in order to produce less distortion and add to overall sonic quality. The road-tested enclosures are equipped with heavy-duty steel grilles and ergonomic, gripped aluminum handles that greatly improve durability.



Intelligent Onboard 3-Channel Mixer

The DXRmkII Series features a flexible onboard mixer with a variety of inputs, making it ideal for simple vocal/ instrument amplification. With its flexible IN/OUT connectivity, the DXR Series can comprise a full sound reinforcement system, or seamlessly integrate into a setup utilizing DZR, DBR or DXS Series speakers.

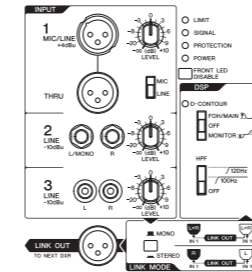

• Versatile Mic and Line Level Input Capacity

• Flexible HPF Control with 100Hz or 120Hz options

• Smart Mixing / Linking Function

Each channel has an individual volume control, letting you mix three discrete audio sources. THRU out passes the input signal from INPUT1 and LINK OUT sends mixed signal from all channels—ideal for daisy-chaining or routing the signal to another destination. LINK OUT is very useful for configuring a compact SR system with another DXR, while LINK MODE allows you to easily switch between stereo or dual-mono configurations.

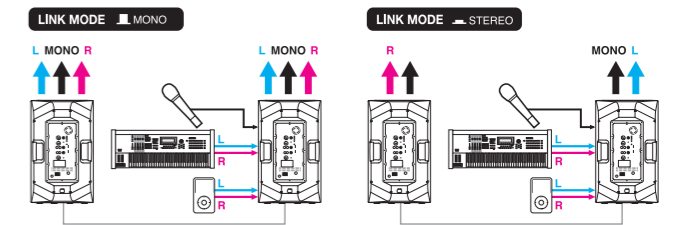

Smart Enclosure Design for Floor Monitoring

DXR10mkII, DXR12mkII and DXR15mkII models have optimal 50° wedge angle for floor monitor use. In addition, the DXR12mkII and DXR15mkII's enclosure design enables mirror-mode monitor placement that can create either a symmetrical sound field for the performer with a larger, more defined "sweet spot" or a stereo sound field setup.



Dual-Angle Pole Mount Socket

DXR's pole mount socket offers two positions—0° and 7°—to direct the acoustic energy away from reflective surfaces in a room with low ceilings and on to your audience where it belongs.



Rigging Points for Standard Eye-bolts and Optional U-Brackets

DXRmkII Series loudspeakers come equipped with rigging points, allowing for rigged application with standard eyebolts*. When more versatility is required, optional U-brackets allow simple and easy rigging in both horizontal and vertical configurations.

*Eyebolts not included.

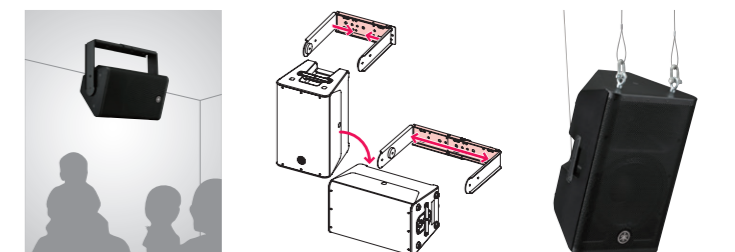

| | Power ¹ | Maximum SPL ² | Frequency Range (-10dB) | LF | HF | Coverage Angle |
|------------------|--------------------|--------------------------|-------------------------|----------|----------------------------|----------------|
| DXR15mkII | 1100W | 134dB SPL | 49Hz-20kHz | 15" Cone | 1.75" diaphragm, 1" throat | H90° x V60° |
| DXR12mkII | 1100W | 134dB SPL | 52Hz-20kHz | 12" Cone | 1.75" diaphragm, 1" throat | H90° x V60° |
| DXR10mkII | 1100W | 132dB SPL | 56Hz-20kHz | 10" Cone | 1.75" diaphragm, 1" throat | H90° x V60° |
| DXR8mkII | 1100W | 130dB SPL | 57Hz-20kHz | 8" Cone | 1.75" diaphragm, 1" throat | H90° x V60° |

¹Dynamic power ²Measured Maximum SPL (peak)

SERIOUS. BASS. PERFORMANCE.

Prepare to make a lasting impression on your audience with the addition of DXS Series high-output, powered subwoofers to your sound reinforcement system. Featuring high-efficiency Class-D amplifiers and a customized woofer housed in a sturdy enclosure with a band-pass construction, DXS subwoofers are able to deliver up to 1020W of raw power with minimal distortion and superb clarity. Each of the three models that make up the series— the compact DXS12mkII and DXS15mkII, as well as the new, high output DXS18—comes equipped with Yamaha state-of-the-art DSP processing, protection functions, and flexible crossover control, ensuring versatile management of your bottom end and seamless compatibility with Yamaha's entire lineup of full-range powered speakers. DXS Series powered subwoofers offer a new level of flexibility, reliability, and power for engineers, artists and audiences that are serious about their bass.



High-Efficiency 1020W Class-D Amplifiers

The DXS's high performance Class-D amplifier is capable of producing up to 1020W* of power, realizing an SPL of 136dB, delivered with exceptional clarity and accuracy.

Custom Designed Transducer

The high-output woofer of DXS18 features a 4" voice coil magnet and delivers powerful, well-defined, low-frequency bass with minimal distortion. The DXS12mkII and DXS15mkII both feature 2.5" voice coil magnets.

Durable Wooden Enclosures with LINE-X® Coating

The exteriors feature a LINE-X® coating with extremely high damage resistance to protect the cabinet from scratches and wear, maintaining a professional appearance that can withstand many years of usage. grilles and ergonomic, gripped aluminum handles that greatly improve durability.

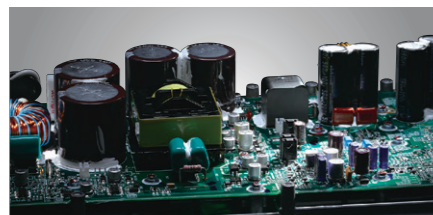

Band-Pass Type Enclosure

The DXS Series has a band-pass design that produces extremely high SPL by drastically reducing the distortion.



Dual pole socket

For additional flexibility configuring your speakers, the DXS18 comes equipped with a dual pole socket that accommodates 35mm diameter speaker poles and M20 screws.

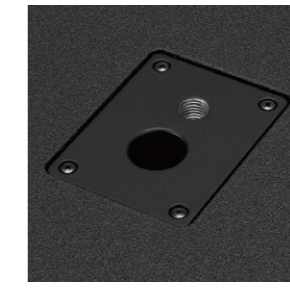

Ultimate Bass control

D-XSUB Bass Processing

Powerful D-XSUB processing gives you total control of your low frequency. NORMAL mode gives you the ideally balanced low-frequency response, while BOOST mode provides a more tight and focused bass. XTENDED LF mode drops the low-end frequencies down even further for thunderous bottom end that delivers. Take your full-range system to the next level with the power and versatility of DXS Series active subwoofers.

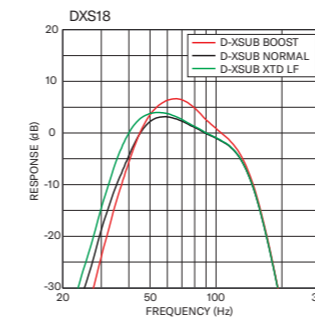

Cardioid Mode

Because low frequencies can be omnidirectional, controlling the output directivity of a system's bottom end can be a challenge, with the sound pressure hitting the stage often being equal to that of its intended FOH audience. For setups consisting of two or more DXS18 subwoofers, selecting the newly developed Cardioid Mode function effectively decreases stage-side sound pressure while increasing the bottom-end output directed towards the audience, resulting in a clearer stage monitoring environment and a more pronounced bass experience out front.

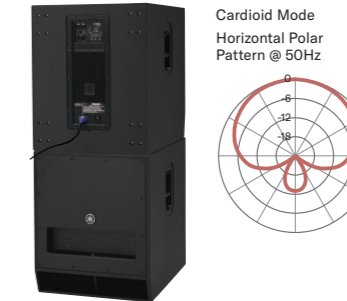

Selectable X-OVER (80/100/120Hz)

Crossover switching allows users to seamlessly match DXS subwoofers with any of Yamaha's full-range powered speakers by selecting the cutoff frequency best suited to the models in their speaker array (up to 120Hz).

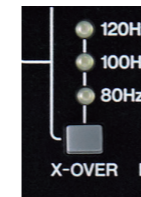

Optional Wheel kit



For more fast and convenient setup of your DXS subwoofers, optional wheels are available, featuring radial ball bearings that ensure quiet during your performance.

| | Power ¹ | Maximum SPL ² | Frequency Range (-10dB) | LF |
|------------------|--------------------|--------------------------|-------------------------|----------|
| DXS18 | 1020W | 136dB SPL | 32Hz-120kHz | 18" Cone |
| DXS15mkII | 1020W | 135dB SPL | 40Hz-150kHz | 15" Cone |
| DXS12mkII | 1020W | 134dB SPL | 42Hz-150kHz | 12" Cone |

¹ Dynamic power ² Measured Maximum SPL (peak)

PERFORMANCE. OPTIMIZED.

The DHR Series offers an ideal solution for anyone ready to step up their sound reinforcement game to a new level of professional quality, accuracy, and performance. Premium plywood cabinets finished in a tough polyurea coating provide durability not found on other loudspeakers in this class. Each model in the series has been optimized to meet the demands of a variety of sound reinforcement applications, with DHR10 and DHR12 for fixed installation and utilities, DHR12M and DHR15M designed for use as floor monitors, and DHR15 for FOH applications—all featuring custom transducers driven by DSP-equipped class-D power amplifiers to deliver stunning sound quality and clarity. Combined with practical features adapted for their specific applications, this series gives you the flexibility to choose the ideal speaker for a wide variety of sonic environments. Take DHR for a test drive and experience the exceptional quality and performance for yourself!



Cabinet designs optimized for a range of audio environments

The DHR Series features a comprehensive lineup of powered loudspeakers with cabinets optimized to meet the demands of specific applications. DHR10 and DHR12 are equipped with rotating horns and a dedicated U-bracket for use in fixed installations and utility, while DHR12M and DHR15M feature a coaxial compression driver for improved clarity and smoother frequency response for floor monitoring. The series is rounded out by DHR15, which features rigging points for use in fixed installations. DHR12 and DHR15 also feature dual-angle pole sockets, allowing them to be used as temporary main speakers for sound reinforcement.



DHR10/DHR12



DHR12M/DHR15M

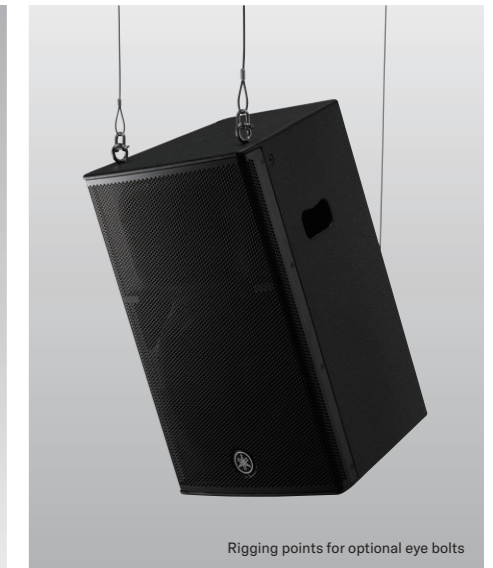

Rigging points for optional eye bolts
 DHR15

Easy-to-use Onboard 2-Channel Mixer

DHR Series speakers have two input channels. CH1 has a combo jack that accepts either XLR and TRS Phone allowing Mic or Line level input signals. CH2 offers two input options;

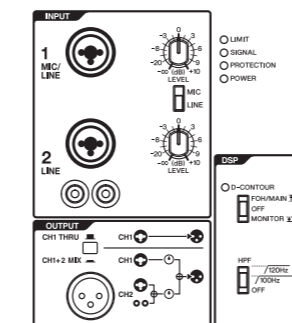

a combo jack that accepts XLR or TRS Phone, and a pair of RCA pin Jacks for input from CD players or other stereo line-level sources. The onboard mixer allows you to select either CH1+2 MIX to mix the signal of CH1 and CH2, or CH1 THRU to pass the signal from CH1 only.

Dual-Angle Pole Mount Socket (DHR12, DHR15)

The pole mount socket on DHR12 and DHR15 offers two positions—0° and 7°—to direct acoustic energy away from reflective surfaces in rooms with low ceilings and onto your audience where it belongs.



High-Efficiency 1000W Class-D Amplifiers

The DHR's lightweight, high performance Class-D amplifier is capable of producing up to 1000W* of power, achieving an SPL of 131dB, delivered with remarkable clarity and dynamic characteristics.

*DHR10 has an output level of 700W.

Custom Designed Transducers

The high power output woofers deliver well-defined, powerful bass with minimal distortion, while the 1.4" precision compression driver* produces accurate mid-range and high frequencies.

*DHR12M and DHR15M feature a 1.75" coaxial compression driver.

A Rugged, Highly Portable Cabinet

Like our acclaimed DZR loudspeakers, the DHR Series feature plywood enclosures that deliver outstanding durability and acoustic performance.



15" coaxial driver



| | Power ¹ | Maximum SPL ² | Frequency Range (-10dB) | LF | HF | Coverage Angle |
|---------------|--------------------|--------------------------|-------------------------|----------|----------------------------|-------------------------|
| DHR15 | 1000W | 131dB SPL | 44Hz-20kHz | 15" Cone | 1.4" diaphragm, 1" throat | H90° x V60° |
| DHR12 | 1000W | 130dB SPL | 48Hz-20kHz | 12" Cone | 1.4" diaphragm, 1" throat | H90° x V60° (Rotatable) |
| DHR10 | 700W | 128dB SPL | 52Hz-20kHz | 10" Cone | 1.4" diaphragm, 1" throat | H90° x V60° (Rotatable) |
| DHR15M | 1000W | 131dB SPL | 50Hz-20kHz | 15" Cone | 1.75" diaphragm, 1" throat | H65° x V75° |
| DHR12M | 1000W | 129dB SPL | 55Hz-20kHz | 12" Cone | 1.75" diaphragm, 1" throat | H90° x V90° |

¹ Dynamic power ² Measured Maximum SPL (peak)

POWER TO PLAY

Wherever your music may take you, DBR Series loudspeakers are up to the task of delivering powerful, high-quality sound with an un-matched economy of transport and setup time. The most portable powered loudspeakers Yamaha has to offer, the versatile DBR Series harnesses the same state-of-the-art Yamaha DSP and amplifier and speaker technologies developed for the professional DSR Series and DXR Series lineups, ensuring high-resolution sound at any output level. Comprised of 10", 12" and 15" models, each DBR loudspeaker is housed in a newly designed, durable, lightweight cabinet optimized for FOH sound, floor-monitoring and even rigged applications. Whether you're powering your band's live performance, DJ-ing a party, or MC-ing an event, be prepared for DBR Series speakers to take your performance to the next level.



Smart Enclosure Design for Floor Monitoring

DBR Series speakers feature an optimized 50° wedge angle for floor monitoring. In addition the DBR12 and DBR15's symmetrical shape allows for effortless configuration of a mirror-mode floor monitoring system in either symmetrical or stereo sound field setups.

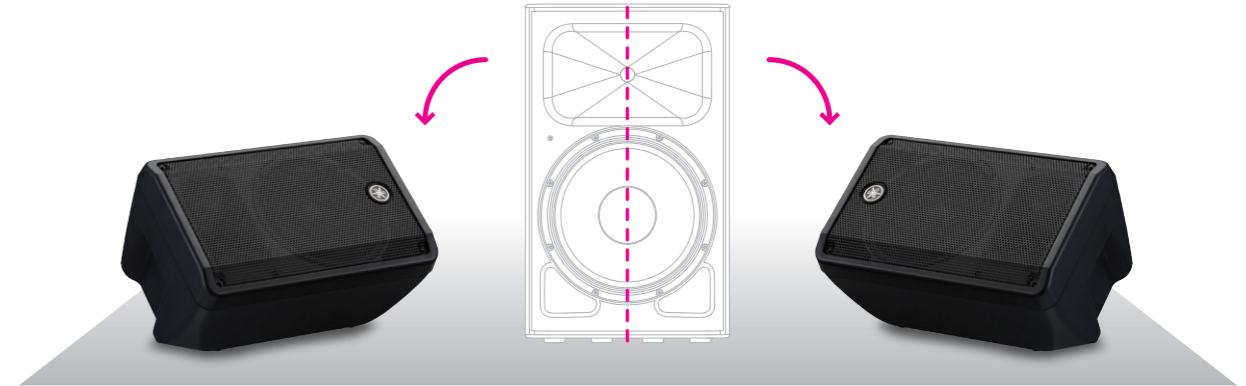

Easy-to-use Onboard 2-Channel Mixer

DBR Series speakers have two input channels. CH1 has a combo jack which accepts both XLR and TRS Phone allowing for either Mic or Line level input signals. CH2 offers two input options; a combo jack that accepts XLR or TRS Phone, and a pair of RCA pin Jacks for input from CD players or other stereo line-level sources. The onboard mixer allows you to select either CH1+2 MIX to mix the signal of CH1 and CH2, or CH1 THRU to pass the signal from CH1 only.

Rigging Points for Installation Applications

DBR loudspeakers come equipped with M8 rigging threads, allowing for rigged applications with 3rd party's speaker brackets or standardized eye-bolts.

* Speaker brackets and eye-bolts are not included.

** You can use optional brackets sold separately. For more information, visit the following Yamaha Pro Audio website: <https://www.yamahaproaudio.com/>

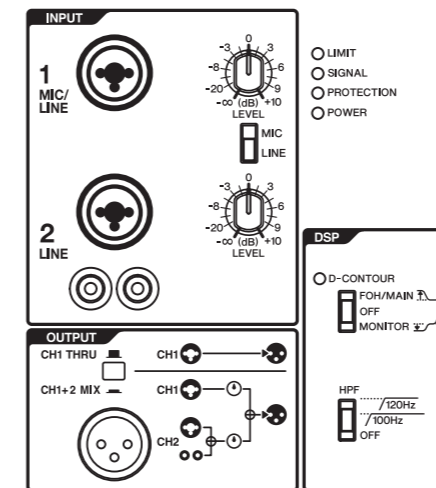

DBR SERIES

High-Efficiency 1000W Class-D Amplifiers

The DBR's lightweight, high performance Class-D amplifier is capable of producing up to 1000W* of power, achieving an SPL of 132dB, delivered with remarkable clarity and dynamic characteristics.

*DBR10 has an output level of 700W.

Custom Designed Transducer

The high power output woofers deliver well-defined, powerful bass with minimal distortion, while the 1.4" precision compression driver* produces accurate mid-range and high frequencies.

*DBR10 features a 1" compression driver.

A Rugged, Highly Portable Cabinet

DBR Series speakers feature a compact, lightweight, and durable plastic cabinet which offers the highest level of portability of all Yamaha powered speakers. The sleek steel grill bolsters cabinet durability and protects the internal components while a newly designed ergonomic handles provide effortless transportation and system setup.



| | Power ¹ | Maximum SPL ² | Frequency Range (-10dB) | LF | HF | Coverage Angle |
|--------------|--------------------|--------------------------|-------------------------|----------|---------------------------|----------------|
| DBR15 | 1000W | 132dB SPL | 50Hz-20kHz | 15" Cone | 1.4" diaphragm, 1" throat | H90° x V60° |
| DBR12 | 1000W | 131dB SPL | 52Hz-20kHz | 12" Cone | 1.4" diaphragm, 1" throat | H90° x V60° |
| DBR10 | 700W | 129dB SPL | 55Hz-20kHz | 10" Cone | 1" diaphragm, 1" throat | H90° x V60° |

¹ Dynamic power ² Measured Maximum SPL (peak)

PORTABLE POWERHOUSE

The DXL1K is a column-type powered speaker with a powerful 125dB SPL peak@1m sound output that belies its extremely portable slim body (a dedicated carrying cart is sold separately). The combination of an easy setup procedure that only requires the line-array speaker to be attached to the top of the subwoofer cabinet, with the system expandability offered by the Link function, allows the DXL1K to be used in combination with a compact mixer or with the fully compatible STAGEPAS 1K mkII, creating a simple, compact, and high-quality PA system.

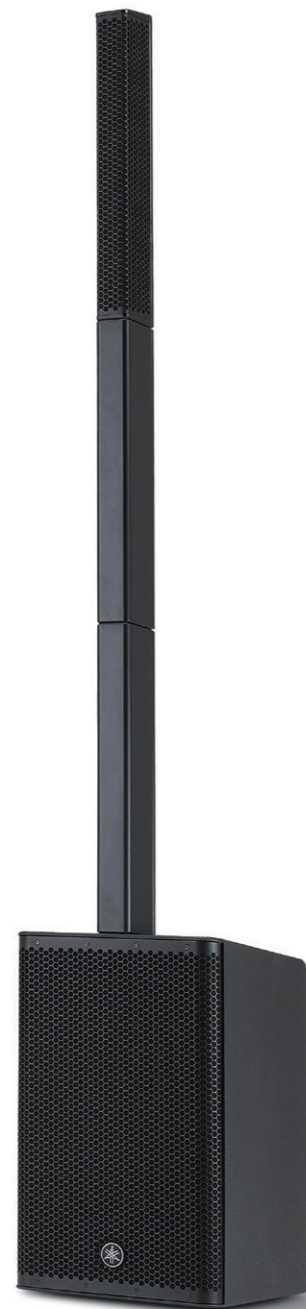

D BR SERIES

J-Curve Slim Line Array

The high-frequency speaker array is comprised of 10 small-diameter 1.5" speakers. By adopting a J-curve array configuration, the high-frequency unit achieves vertical coverage of 30 ° across a span of 170 °. With such a long, 10-driver array design the DXL1K can deliver clear, high quality sound consistently over longer distances, projecting uniform, high-quality sound from the front to the rear of the audience.



Class-leading 12-inch "compact" subwoofer

The subwoofer features a 12-inch speaker unit which is hardly "compact," and actually the largest in its class. Despite housing a 12-inch speaker unit that is the largest in its class, the DXL 1K boasts the smallest cabinet on the market for a subwoofer of this size and power. By incorporating Yamaha's own Twisted Flare Port™ technology to reduce port wind noise that can occur with compact bass-reflex subwoofers, the low-end output is maximized, producing very deep, powerful, distortion-free bass.



High efficiency "1100" W Class-D amplifier

Also at the top of its class for output power, the 1100W Class-D amplifier module is capable of delivering an impressive 125 dB SPL from the deceptively compact speaker cabinet. And just as importantly, we've leveraged Yamaha's decades-long experience as a manufacturer of professional PA products, and innovator of related technologies to ensure that with great power comes great stability, and that the DXL1K maintains the same accurate, superior-quality sound even at high output.



High-grade polyurea coating

The lightweight ABS cabinet of subwoofer features a high-grade polyurea coating to prevent wear and tear during transport. It is light enough to make the system extremely portable, but also rugged and scratch-resistant enough to withstand harsh performance environments.



Simple setup

Simply place the 2 spacers and speaker unit into the subwoofer and setup is essentially done, with no cables, speaker stand, or additional gear required beyond the main unit. All you need is in the package.



Expandable STAGEPAS systems

Linking a DXL1K and STAGEPAS 1K mkII provides greater coverage area and increased output power for large-scale performances. Both stereo and mono playback are supported, and when the STAGEPAS 1K mkII is set to mono, the inputs of the DXL1K and STAGEPAS 1K mkII can still be used (up to five mono inputs plus one stereo input).



Fitted cover included

The DXL1K comes with its own cover which, in addition to protecting the unit, has pouches for both spacers and speaker array as well as additional storage for accessories to further streamline system setup and teardown.



Optional dolly (DL-SP1K)

An optional dedicated dolly allows for more convenient transportation — particularly useful for performers transporting additional gear and instruments. Featuring a simple, sturdy mechanism that locks down the speaker cover the lightweight dolly enables smooth, reliable transportation.



| | Power ¹ | Maximum SPL ² | Frequency Range (-10dB) | LF | HF | Coverage Angle |
|--------------|--------------------|--------------------------|-------------------------|----------|-----------|----------------|
| DXL1K | 1,100W | 125dB SPL | 37Hz-20kHz | 12" Cone | 1.5" Cone | H170° x V30° |

¹ Dynamic power ² Measured Maximum SPL (peak)

Dimensions

DZR315/315-D

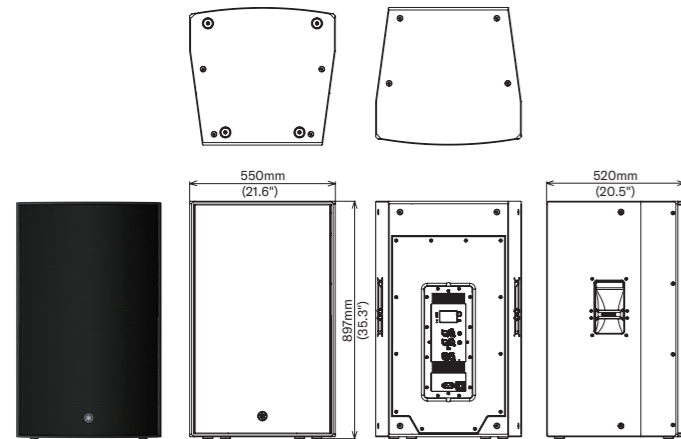

DZR15/15-D

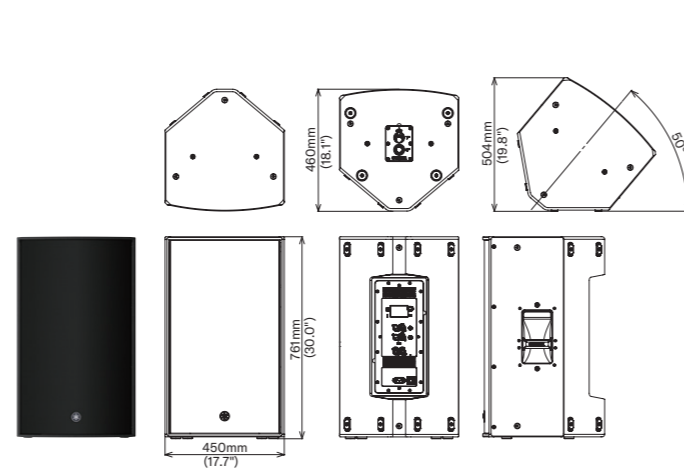

DZR12/12-D

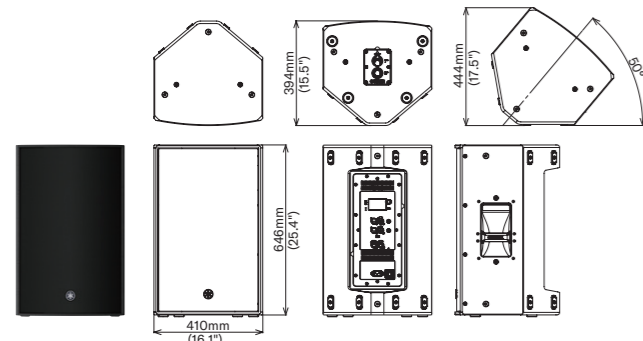

DZR10/10-D

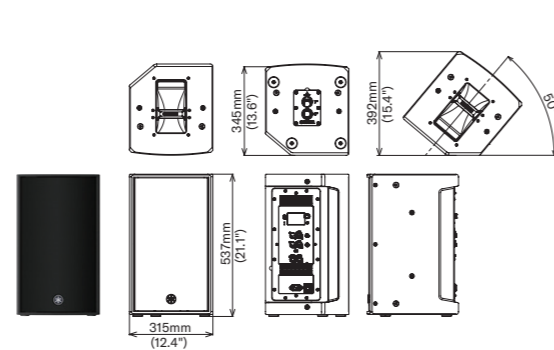

Rear Panel & Block Diagram DZR(-D)

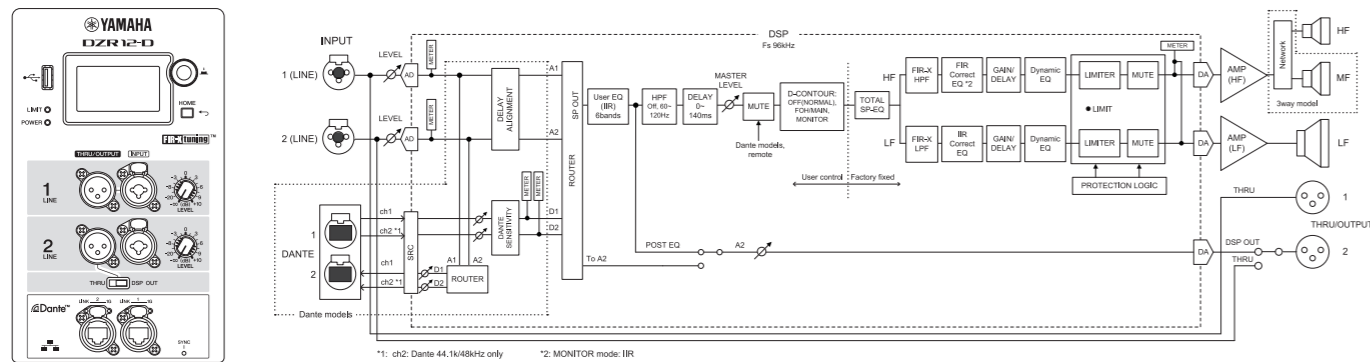

*1: ch2: Dante 44.1k/48kHz only *2: MONITOR mode: IIR

Dimensions

DXR15mkII

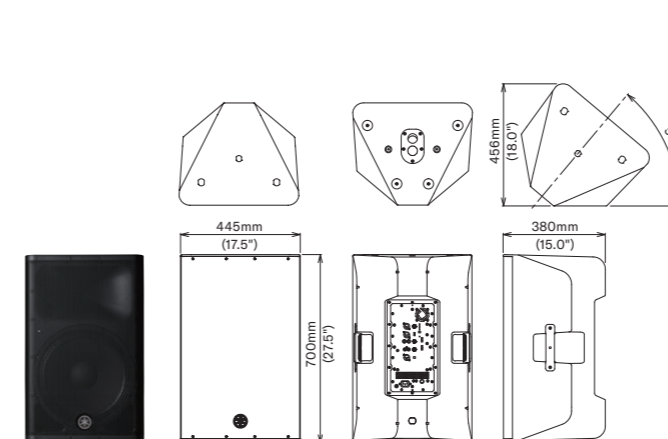

DXR12mkII

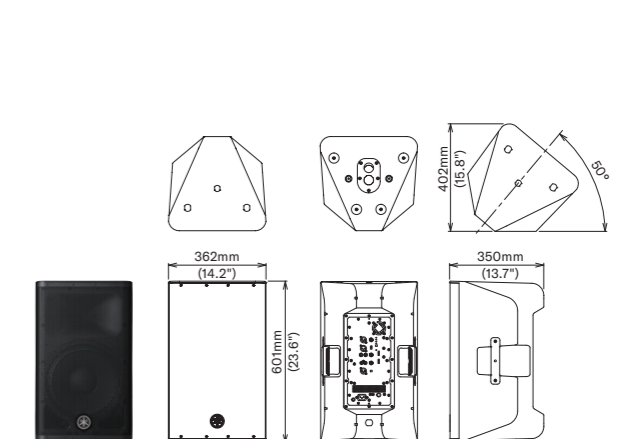

DXR10mkII

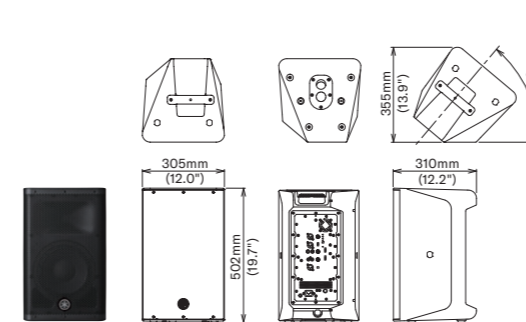

DXR8mkII

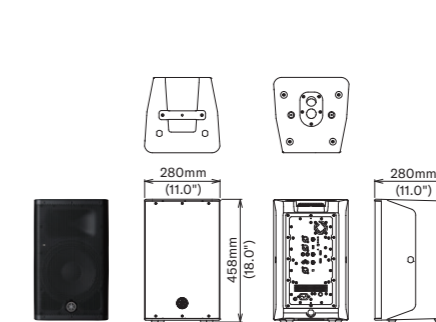

Rear Panel & Block Diagram DXRmkII Series

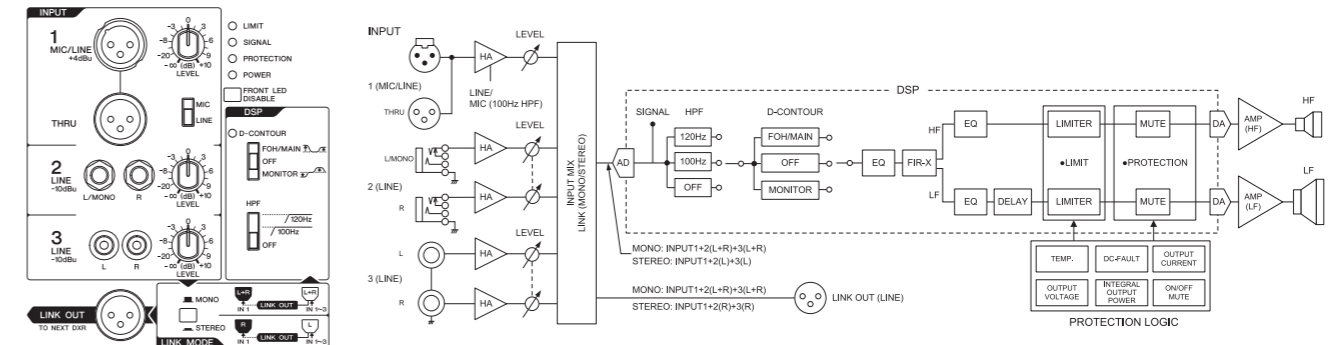

Dimensions

DHR15

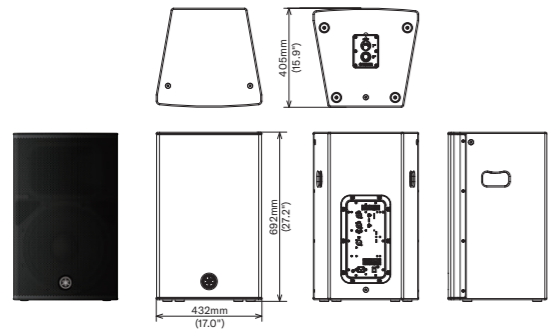

DHR12

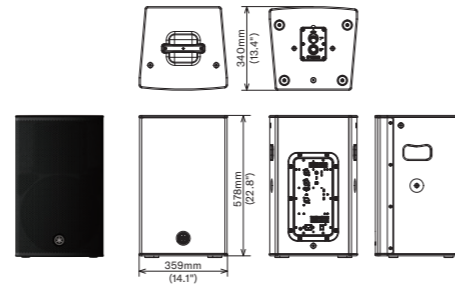

DHR10

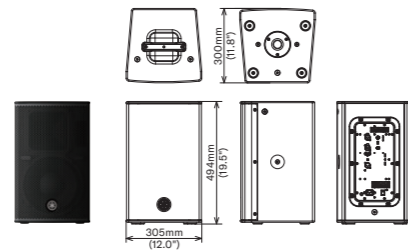

DHR15M

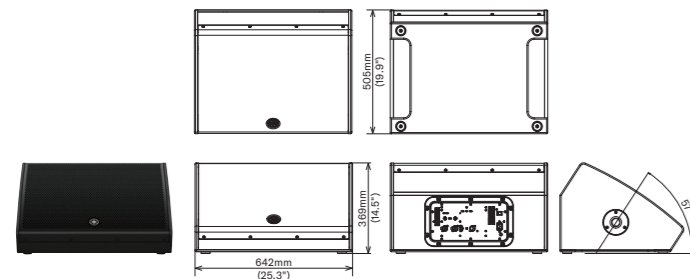

DHR12M

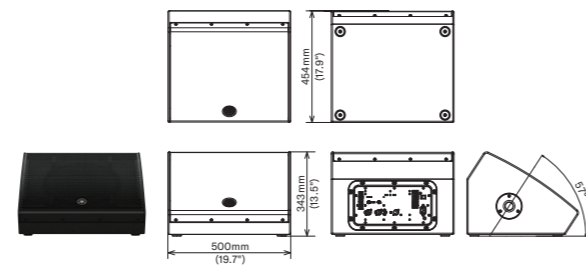

Rear Panel & Block Diagram DHR Series

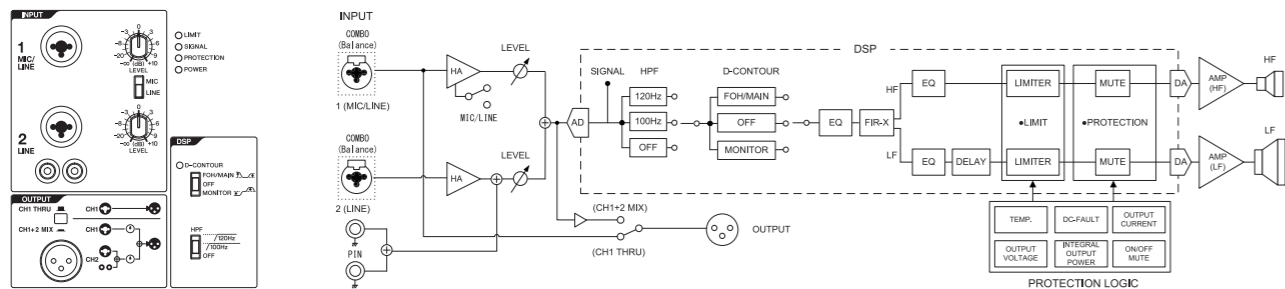

Dimensions

DBR15

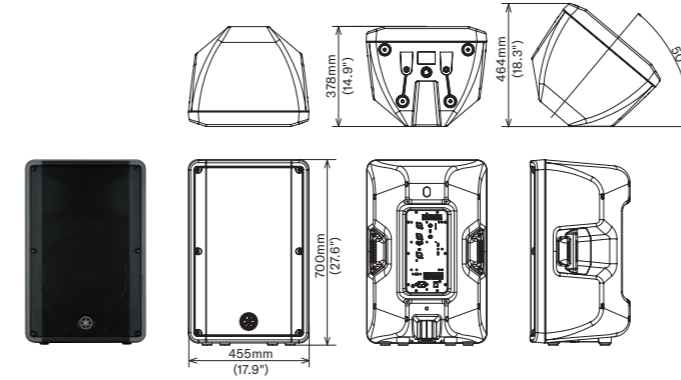

DBR12

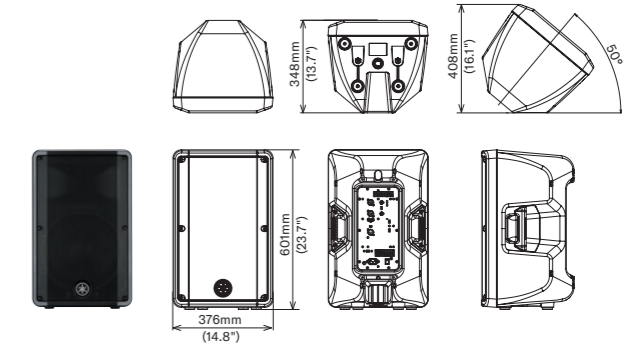

DBR10

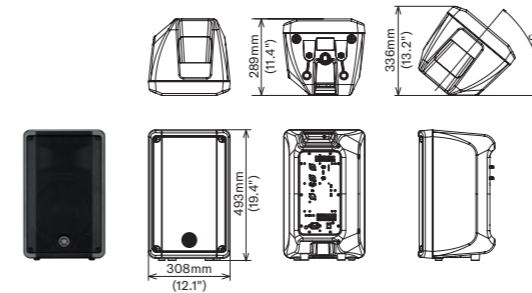

Rear Panel & Block Diagram DBR Series

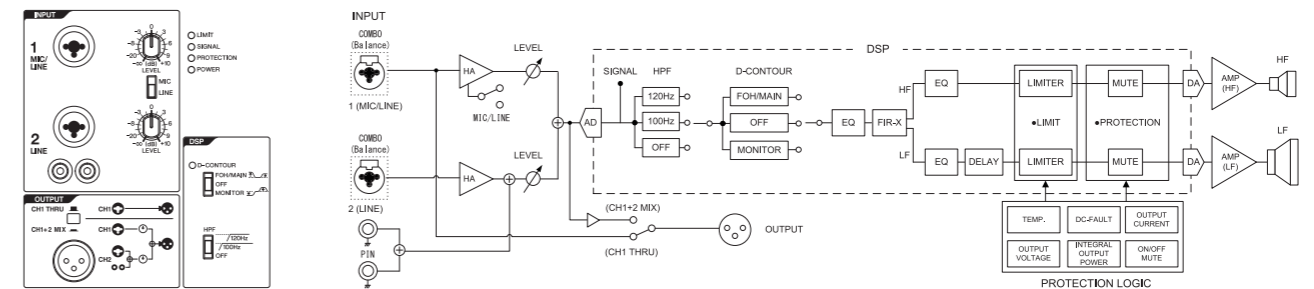

Dimensions

DXS18XLF/18XLF-D

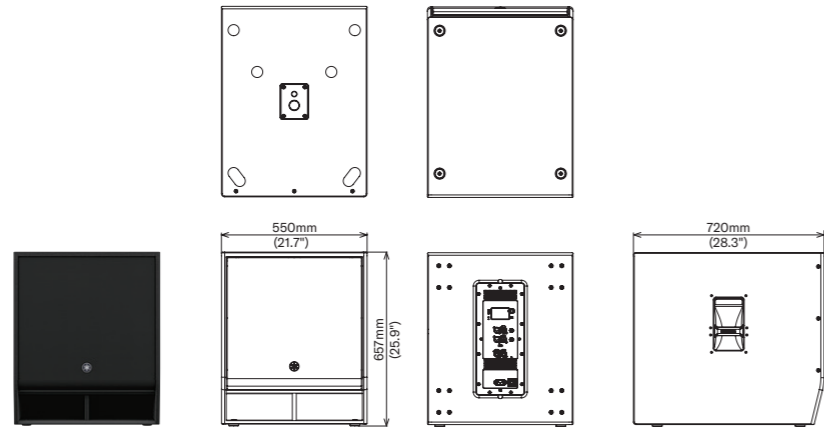

DXS15XLF/15XLF-D

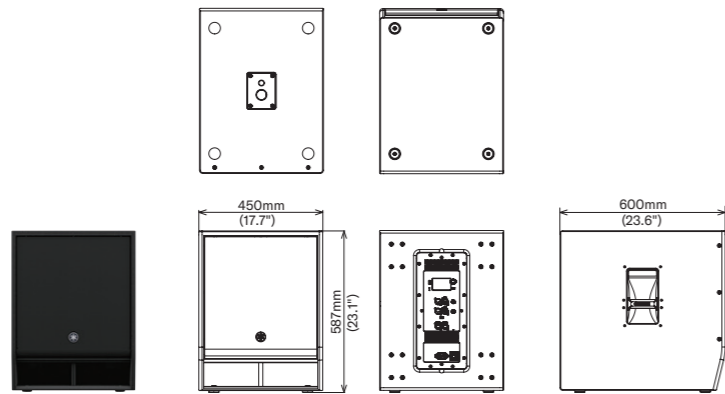

Rear Panel & Block Diagram DXS-XLF(-D)

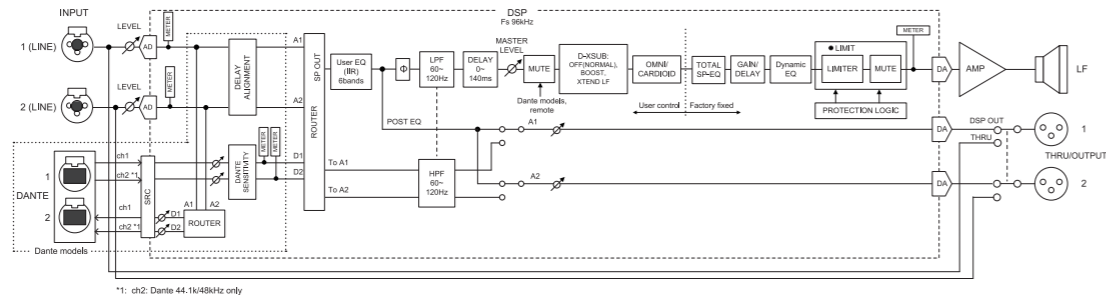
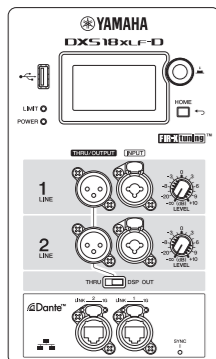

*1: ch2: Dante 44.1k/48kHz only

Dimensions

DXS18

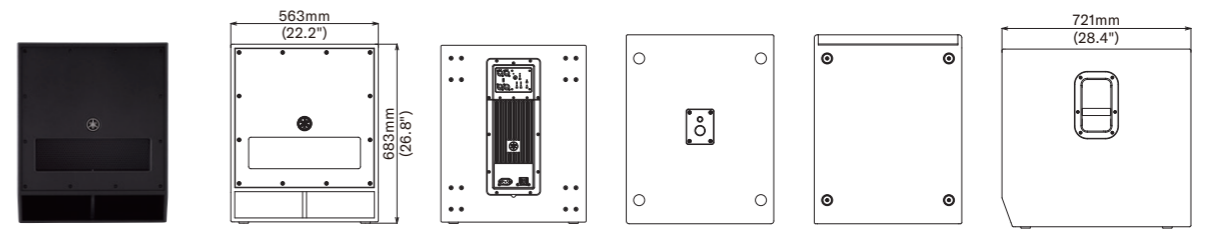

DXS15mkII

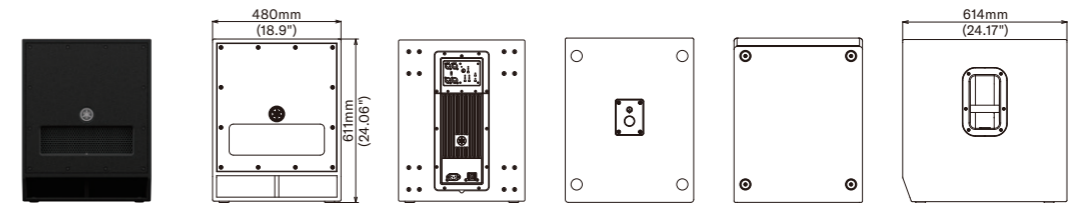

DXS12mkII

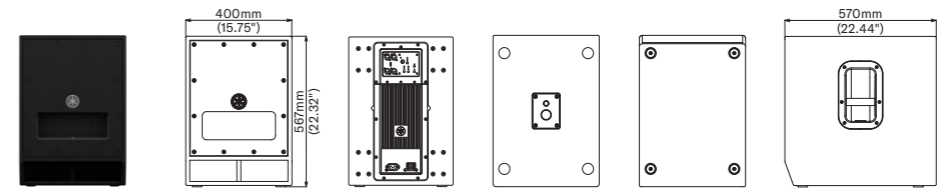

Rear Panel & Block Diagram DXS Series

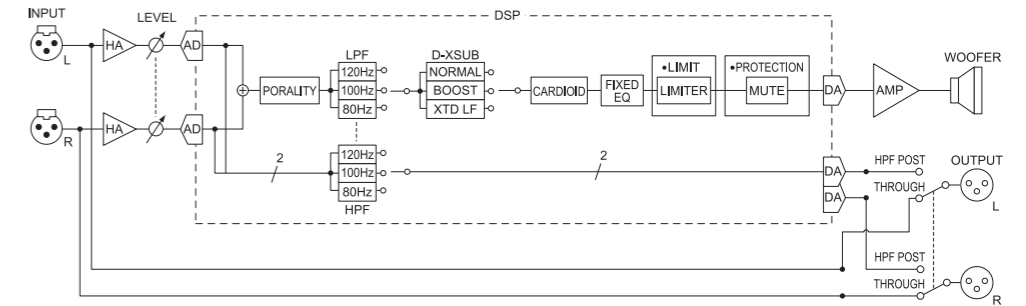
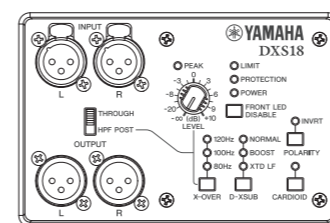

Dimensions

DXL1K

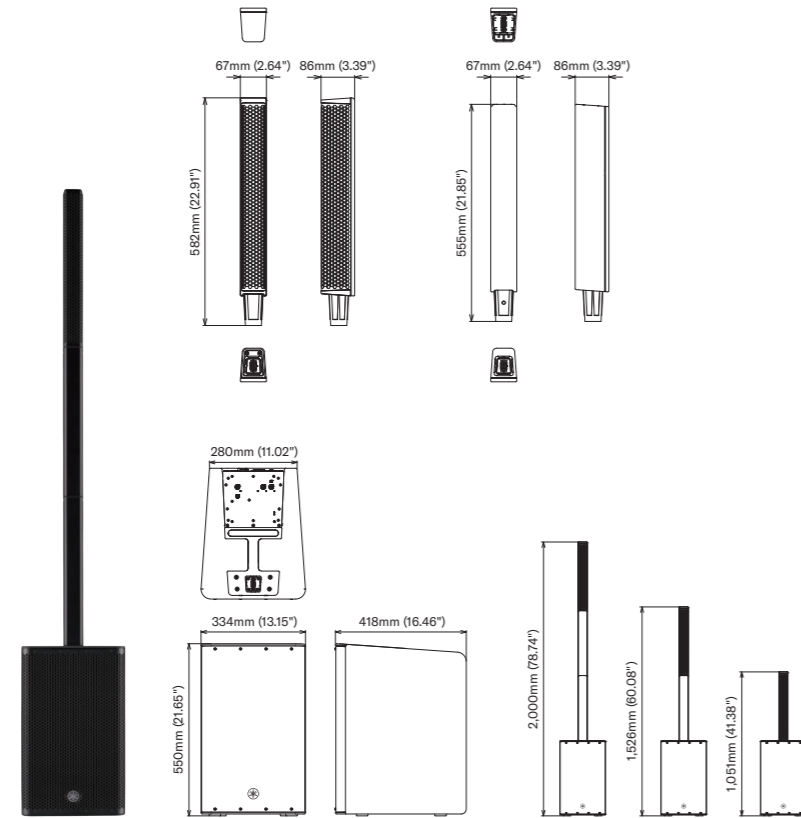

Rear Panel & Block Diagram DXS-XLF(-D)

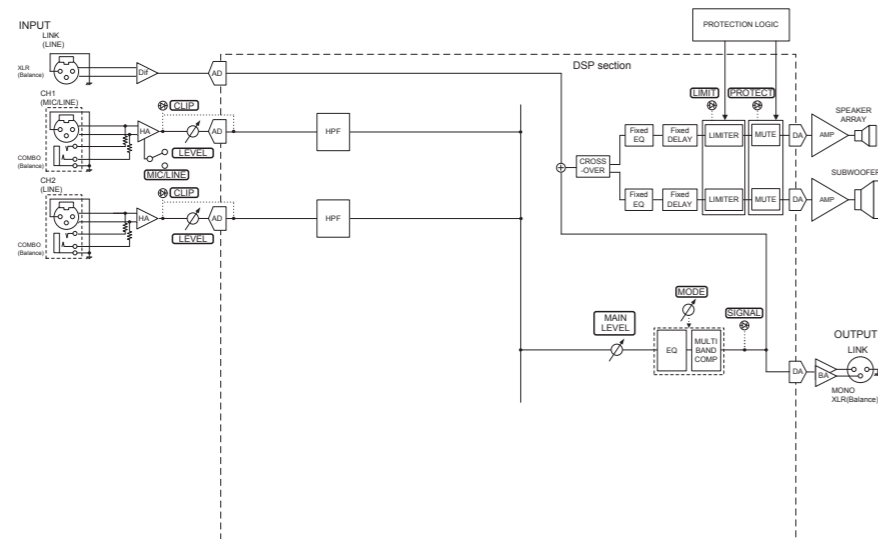

Specifications

| | DZR315/315-D | DZR15/15-D | DZR12/12-D | DZR10/10-D |
|--|---|---|--|--|
| General | | | | |
| System Type | 3-way, Bi-amped Powered Speaker, Bass-reflex | 2-way, Bi-amped Powered Speaker, Bass-reflex | | |
| Frequency Range (-10dB) | 31Hz - 20kHz | 34Hz - 20kHz | 39Hz - 20kHz | 44Hz - 20kHz |
| Coverage Angle | H75° x V50° | H90° x V50° (Rotatable) | H90° x V60° (Rotatable) | |
| Crossover | Type | Advanced FIR-X tuning™ (Linear phase FIR filter) | | |
| | Frequency | 700Hz(FIR-X), 2.5kHz(Passive) | 1.7kHz | 1.8kHz |
| Maximum SPL*1 | 143dB SPL | 139dB SPL | 139dB SPL | 137dB SPL |
| Transducer | | | | |
| LF | Diameter | 15" Cone | | 12" Cone |
| | Voice Coil | 3" | | |
| | Magnet | Neodymium | | |
| MF | Diameter | 8" Cone | - | - |
| | Voice Coil | 1.5" | - | - |
| | Magnet | Ferrite | - | - |
| HF | Diaphragm | 2" Titanium | | |
| | Type | 1" Throat Compression Driver | | |
| | Magnet | Neodymium | | |
| Enclosure | | | | |
| Material, Finish, Color | Plywood, Durable Polyurea coating, Black | | | |
| Floor Monitor Angle | - | 50° Symmetrical | | 50° |
| Dimensions (W x H x D, with rubber feet) | 550 x 897 x 520mm 21.6" x 35.3" x 20.5" | 450 x 761 x 460mm 17.7" x 30.0" x 18.1" | 410 x 646 x 394mm 16.1" x 25.4" x 15.5" | 315 x 537 x 345mm 12.4" x 21.1" x 13.6" |
| Net Weight | 41.6kg (91.7lbs) | 25.2kg (55.6lbs) | 21.4kg (47.2lbs) | 17.9kg (39.5lbs) |
| Handles | Side x2 | | | Top x1, Side x1 |
| Pole Socket | - | Φ35 mm x2 (0° or -7°) | | |
| Rigging Points for eyebolts | M10 x16 (L:30-50mm) | M10 x12 (L:30-50mm) | | M10 x8, M8 x2 (L:30-50mm) |
| Options | Speaker Bracket | - | UB-DZR15H/V | UB-DZR12H/V |
| | Speaker Cover | SPCVR-DZR315 | SPCVR-DZR15 | SPCVR-DZR12 |
| | Wheel Kit | - | - | - |
| Amplifier & DSP | | | | |
| Amplifier Type | Class-D | | | |
| Power Rating*1 | Dynamic*2 | 2000W (LF:1000W, MF/HF: 1000W) | | |
| | Continuous | 950 W (LF: 850 W, MF/HF: 100 W) | | |
| Cooling | Fan cooling, Variable speeds | | | |
| AD/DA | 24 bit / 96 kHz Sampling | | | |
| HPF/LPF | HPF (60Hz-120Hz) | | | |
| DSP control, preset | D-CONTOUR (FOH/MAIN, MONITOR, OFF), EQ (6bands), Delay (0-140ms), Routing | | | |
| Protection | Speaker | Clip limiting, Integral Power Protection, DC-fault | | |
| | Amplifier | Thermal, Output over current | | |
| | Power Supply | Thermal, Output over voltage, Output over current | | |
| Connectors | Analog Input | Combo x2 | | |
| | Analog Output | XLR3-32 x2, CH1: THRU (fix), CH2: THRU or DSP OUT | | |
| | Digital I/O (-D model only) | etherCON CAT5e x2 (Daisy Chain), 2 IN/2 OUT (Fs: 44.1k, 48k, 88.2k, 96k) and Remote Control, 1000BASE-T | | |
| | USB | USB2.0 Host 5V 500mA, for DATA storage/load | | |
| AC IN | IEC AC inlet x1 (V-Lock) | | | |
| Analog Input Impedance | 20kΩ | | | |
| Analog Input Sensitivity | (LEVEL: Maximum) | - | - | - |
| | (LEVEL: Center) | - | - | - |
| Maximum Analog Input Level | +24dBu | | | |
| Controls | Main knob, HOME(Back), LEVEL x2, THRU/DSP, POWER | | | |
| Power Consumption | Idle | 45W | | |
| | 1/8 Power | 150W | | |
| Power Requirements | Depending on area of purchase; 100V-240V, 50Hz/60Hz | | | |

*1: Measured peak SPL with pink noise @1m.

*2: Total peak power of individual outputs (AC 120V, 25°C). This value was measured at minimum load impedance, with protection released.

Specifications

| | | DXS18XLF/18XLF-D | DXS15XLF/15XLF-D | DXR15mkII | DXR12mkII |
|--|-----------------------------|---|--|---|--|
| General | | | | | |
| System Type | | Powered Subwoofer, Bass-reflex | | 2-way, Bi-amped Powered Speaker, Bass-reflex | |
| Frequency Range (-10dB) | | 30Hz - 150Hz | 33Hz - 150Hz | 49Hz - 20kHz | 52Hz - 20kHz |
| Coverage Angle | | - | - | H90° x V60° | |
| Crossover | Type | - | - | FIR-X tuning™ (Linear phase FIR filter) | |
| | Frequency | - | - | 2.1kHz | 2.1kHz |
| Maximum SPL*1 | | 136dB SPL | | 134dB SPL | 134dB SPL |
| Transducer | | | | | |
| LF | Diameter | 18" Cone | 15" Cone | 15" Cone | 12" Cone |
| | Voice Coil | 4" | | 2.5" | |
| | Magnet | Ferrite | | Ferrite | |
| MF | Diameter | - | - | - | - |
| | Voice Coil | - | - | - | - |
| | Magnet | - | - | - | - |
| HF | Diaphragm | - | - | 1.75" PET | |
| | Type | - | - | 1" Throat Compression Driver | |
| | Magnet | - | - | Neodymium | |
| Enclosure | | | | | |
| Material, Finish, Color | | Plywood, Durable Polyurea coating, Black | | ABS, Matte black | |
| Floor Monitor Angle | | - | - | 50° Symmetrical | |
| Dimensions (W x H x D, with rubber feet) | | 550 x 657 x 720mm 21.7" x 25.9" x 28.3" | 450 x 587 x 600mm 17.7" x 23.1" x 23.6" | 445 x 700 x 380mm 17.5" x 27.6" x 15.0" | 362 x 601 x 350mm 14.3" x 23.7" x 13.8" |
| Net Weight | | 48.9kg (107.8lbs) | 40.0kg (88.2lbs) | 21.8kg (48.1lbs) | 18.6kg (41.0lbs) |
| Handles | | Side x2 | | Side x2 | |
| Pole Socket | | Φ35 mm (depth 80mm), M20 (Threaded depth 25mm) | | Φ35 mm x2 (0° or -7°) | |
| Rigging Points for eyebolts | | - | - | M10 x3 (Top x2, Rear x1, L:18mm) | |
| Options | Speaker Bracket | - | - | UB-DXR15 | UB-DXR12 |
| | Speaker Cover | SPCVR-DXS18X | SPCVR-DXS15X | SPCVR-1501 | SPCVR-1201 |
| | Wheel Kit | SPW-1 | | - | - |
| Amplifier & DSP | | | | | |
| Amplifier Type | | Class-D | | Class-D | |
| Power Rating*1 | Dynamic*2 | 1600W | | 1100W (LF: 950W, HF: 150W) | |
| | Continuous | 1200W | | 700W (LF: 600W, HF: 100W) | |
| Cooling | | Fan cooling, Variable speeds | | Fan cooling, 4 speeds | |
| AD/DA | | 24 bit / 96 kHz Sampling | | 24 bit / 48 kHz Sampling | |
| HPF/LPF | | LPF (60Hz~120Hz) | | OFF, 100, 120Hz 24dB/oct HPF | |
| DSP control, preset | | D-XSUB (BOOST, XTD LF, NORMAL), EQ (6bands), Delay (0~140ms), Routing | | D-CONTOUR (FOH/MAIN, MONITOR, OFF) | |
| Protection | Speaker | Clip limiting, Integral Power Protection, DC-fault | | Clip limiting, Integral Power Protection, DC-fault | |
| | Amplifier | Thermal, Output over current | | Thermal, Output over current | |
| | Power Supply | Thermal, Output over voltage, Output over current | | Thermal, Output over voltage, Output over current | |
| Connectors | Analog Input | Combo x2 | | INPUT1: XLR3-31 x 1, INPUT2: Phone x 2, INPUT3: RCA PIN x 2 | |
| | Analog Output | XLR3-32 x2, CH1/2: THRU or DSP OUT | | THRU: XLR3-32 x 1 (Parallel with INPUT1), LINK OUT: XLR3-32 x 1 | |
| | Digital I/O (-D model only) | etherCON CAT5e x2 (Daisy Chain), 2 IN/2 OUT (Fs: 44.1k, 48k, 88.2k, 96k) and Remote Control, 1000BASE-T | | - | - |
| | USB | USB2.0 Host 5V 500mA, for DATA storage/load | | - | - |
| | AC IN | IEC AC inlet x1 (V-Lock) | | IEC AC inlet x1 | |
| Analog Input Impedance | | 20kΩ | | INPUT1: LINE= 12kΩ / MIC= 8kΩ, INPUT2&3: L-R= 40kΩ, MONO= 20kΩ | |
| Analog Input Sensitivity | (LEVEL: Maximum) | - | - | INPUT1: LINE= +1dBu / MIC= -32 dBu, INPUT2&3= -13dBu | |
| | (LEVEL: Center) | - | - | INPUT1: LINE= +11dBu / MIC= -22dBu, INPUT2&3= -3dBu | |
| Maximum Analog Input Level | | +24dBu | | INPUT1: LINE= +24dBu, MIC= +20dBu, INPUT2&3= +16dBu | |
| Controls | | Main knob, HOME(Back), LEVEL x2, THRU/DSP, POWER | | LEVEL x3, LINE/MIC, HPF, D-CONTOUR, FRONT LED DISABLE, LINK MODE, POWER | |
| Power Consumption | Idle | 40W | | 35W | |
| | 1/8 Power | 180W | | 110W | |
| Power Requirements | | Depending on area of purchase; 100V-240V, 50Hz/60Hz | | Depending on area of purchase; 100V-240V, 50Hz/60Hz | |

*1: Measured peak SPL with pink noise @1m.

*2: Total peak power of individual outputs (AC 120V, 25°C). This value was measured at minimum load impedance, with protection released.

| DXR10mkII | DXR8mkII | DXS18 | DXS15mkII | DXS12mkII |
|---|--|---|---|---|
| 2-way, Bi-amped Powered Speaker, Bass-reflex | | Powered Subwoofer, Bass-reflex | | |
| 56Hz - 20kHz | 57Hz - 20kHz | 32Hz - 120Hz | 40Hz - 150Hz | 42Hz - 150Hz |
| H90° x V60° | | - | - | - |
| FIR-X tuning™ (Linear phase FIR filter) | | - | - | - |
| 2.3kHz | 2.4kHz | - | - | - |
| 132dB SPL | 130dB SPL | 136dB SPL | 135dB SPL | 134dB SPL |
| 10" Cone | 8" Cone | 18" Cone | 15" Cone | 12" Cone |
| 2" | | 4" | 2.5" | |
| Ferrite | | Ferrite | | |
| - | - | - | - | - |
| - | - | - | - | - |
| - | - | - | - | - |
| 1.75" PET | | - | - | - |
| 1" Throat Compression Driver | | - | - | - |
| Neodymium | | - | - | - |
| ABS, Matte black | | Plywood, Durable Polyurea coating, Black | | |
| 50° | - | - | - | - |
| 305 x 502 x 310mm 12.0" x 19.8" x 12.2" | 280 x 458 x 280mm 11.0" x 18.0" x 11.0" | 563 x 683 x 721 mm 22.2" x 26.8" x 28.4" | 480 x 611 x 614 mm 18.9" x 24.1" x 24.2" | 400 x 567 x 570 mm 15.8" x 22.3" x 22.4" |
| 13.9kg (30.6lbs) | 12.8kg (28.2lbs) | 49.7kg (110lbs) | 36.0 kg (79.4lbs) | 30.0 kg (66.1lbs) |
| Top x 1 | | Side x2 | | |
| Φ35 mm x2 (0° or -7°) | | Φ35 mm (depth 80mm), M20 (Threaded depth 25mm) | | |
| M8 x3 (Top x2, Rear x1, L:15mm) | | - | - | - |
| UB-DXRDRH10 | UB-DXR8 | - | - | - |
| SPCVR-1001 | SPCVR-0801 | SPCVR-18S01 | SPCVR-DXS152 | SPCVR-DXS122 |
| - | - | SPW-1 | | |
| Class-D | | Class-D | | |
| 1100W (LF: 950W, HF: 150W) | | 1020W | | |
| 700W (LF: 600W, HF: 100W) | | 800W | | |
| Fan cooling, 4 speeds | | Natural convection | | |
| 24 bit / 48 kHz Sampling | | 24 bit / 48 kHz Sampling | | |
| OFF, 100, 120Hz 24dB/oct HPF | | 80, 100, 120Hz 24dB/oct LPF | | |
| D-CONTOUR (FOH/MAIN, MONITOR, OFF) | | D-XSUB (BOOST, XTD LF, NORMAL) | | |
| Clip limiting, Integral Power Protection, DC-fault | | Clip limiting, Integral Power Protection, DC-fault | | |
| Thermal, Output over current | | Thermal, Output Through Current | | |
| Thermal, Output over voltage, Output over current | | Thermal, over voltage | | |
| INPUT1: XLR3-31 x 1, INPUT2: Phone x 2, INPUT3: RCA PIN x 2 | | XLR3-31 x2 | | |
| THRU: XLR3-32 x 1 (Parallel with INPUT1), LINK OUT: XLR3-32 x 1 | | XLR3-32 x2 (THROUGH or HPF POST) | | |
| - | - | - | - | - |
| - | - | - | - | - |
| IEC AC inlet x1 | | IEC AC inlet x1 (V-Lock) | | |
| INPUT1: LINE= 12kΩ / MIC= 8kΩ, INPUT2&3: L-R= 40kΩ, MONO= 20kΩ | | 20kΩ | | |
| INPUT1: LINE= +1dBu / MIC= -32 dBu, INPUT2&3= -13dBu | | 0dBu | | |
| INPUT1: LINE= +11dBu / MIC= -22dBu, INPUT2&3= -3dBu | | +10dBu | | |
| INPUT1: LINE= +24dBu, MIC= +20dBu, INPUT2&3= +16dBu | | +24dBu | | |
| LEVEL x3, LINE/MIC, HPF, D-CONTOUR, FRONT LED DISABLE, LINK MODE, POWER | | LEVEL, POLARITY, X-OVER, D-XSUB, CARDIOID, THROUGH/HPF POST, FRONT LED DISABLE, POWER | | |
| 35W | | 35W | | |
| 90W | | 100W | | |
| Depending on area of purchase; 100V-240V, 50Hz/60Hz | | Depending on area of purchase; 100V-240V, 50Hz/60Hz | | |

Specifications

| | | DHR15M | DHR12M | DHR15 | DHR12 | DHR10 |
|--|----------------------------|--|--|--|---|---|
| General | | | | | | |
| System Type | | 2-way, Bi-amped Powered Speaker, Bass-reflex | | | | |
| Frequency Range (-10dB) | | 50Hz-20kHz | 55Hz-20kHz | 44Hz-20kHz | 48Hz-20kHz | 52Hz-20kHz |
| Coverage Angle | | H65° x V75° | H90° x V90° | H90° x V60° | H90° x V60° (Rotatable) | H90° x V60° (Rotatable) |
| Crossover | Type | FIR-X tuning™ (Linear phase FIR filter) | | | | |
| | Frequency | 1.8kHz | 1.8kHz | 1.8kHz | 1.8kHz | 1.9kHz |
| Maximum SPL*1 | | 131dB SPL | 129dB SPL | 131dB SPL | 130dB SPL | 128dB SPL |
| Transducer | | | | | | |
| LF | Diameter | 15" Cone | 12" Cone | 15" Cone | 12" Cone | 10" Cone |
| | Voice Coil | 3" | | 2.5" | | 2" |
| | Magnet | Ferrite | | | | |
| HF | Diaphragm (DXL1K:Diameter) | 1.75" PET | | 1.4" PET | | |
| | Type | 1" Throat Compression Driver, Coaxial | | 1" Throat Compression Driver | | |
| | Magnet | Ferrite | | | | |
| Enclosure | | | | | | |
| Material, Finish, Color | | Plywood, Durable Polyurea coating, Black | | | | |
| Floor Monitor Angle | | 57° | | - | | |
| Dimensions (W x H x D, with rubber feet) | | 642 x 369 x 505mm 25.3" x 14.5" x 19.9" | 500 x 343 x 454mm 19.7" x 13.5" x 17.9" | 432 x 692 x 405mm 17.0" x 27.2" x 15.9" | 359 x 578 x 340mm 14.1" x 22.8" x 13.4" | 305 x 494 x 300mm 12.0" x 19.5" x 11.8" |
| Net Weight | | 23.0 kg (50.7 lbs) | 16.5 kg (36.4 lbs) | 24.0 kg (52.9 lbs) | 19.2 kg (42.3 lbs) | 15.0 kg (33.1 lbs) |
| Handles | | Side x1 | | Side x2 | Top x1, Side x2 | Top x1 |
| Pole Socket | | Φ35 mm x1 | | Φ35 mm x2 (0° or -7°) | | |
| Rigging Points for eyebolts | | - | | Top x 2, Rear x 1 (Fit for M10 x 30 - 50mm Eyebolts) | Top x 2, Rear x 1 (Fit for M10 x 30-50mm Eyebolts), Bottom x2, Side x 2 (Fit for M8 x 55mm UB-DXRDRH12) | Top x 2, Rear x 1 (Fit for M10 x 30-50mm Eyebolts), Bottom x2, Side x 2 (Fit for M8 x 55mm UB-DXRDRH10) |
| Options | Speaker Bracket | - | - | - | UB-DXRDRH12 | UB-DXRDRH10 |
| | Speaker Cover | - | - | - | - | - |
| | Wheel Kit | - | - | - | - | - |
| Amplifier & DSP | | | | | | |
| Amplifier Type | | Class-D | | | | |
| Power Rating*1 | Dynamic*2 | 1000W (LF: 800W, HF: 200W) | | | | 700W (LF: 500W, HF: 200W) |
| | Continuous | 465W (LF: 400W, HF: 65W) | | | | 325W (LF: 260W, HF: 65W) |
| Cooling | | Fan cooling, 4 speeds | | | | |
| AD/DA | | 24 bit / 48 kHz Sampling | | | | |
| HPF/LPF | | OFF, 100, 120Hz 24dB/oct HPF | | | | |
| DSP control, preset | | D-CONTOUR (FOH/MAIN, MONITOR, OFF) | | | | |
| Protection | Speaker | Clip limiting, Integral Power Protection, DC-fault | | | | |
| | Amplifier | Thermal, Output over current | | | | |
| | Power Supply | Thermal, Output over voltage, Output over current | | | | |
| Connectors | Analog Input | INPUT1: Combo x1, INPUT2: Combo x1 + RCA-pin x2 (Unbalanced) | | | | |
| | Analog Output | XLR3-32 x 1 (CH1 Parallel Through or CH1+CH2 Mix) | | | | |
| | AC IN | IEC AC inlet x1 | | | | |
| Analog Input Impedance | | INPUT1 (XLR, TRS Phone) : 3kΩ, INPUT2 (XLR, TRS Phone, RCA Pin) : 10kΩ | | | | |
| Analog Input Sensitivity | (LEVEL: Maximum) | INPUT1 : LINE= 0dBu / MIC= -32dBu, INPUT2= 0dBu | | | | |
| | (LEVEL: Center) | INPUT1 : LINE= +10dBu / MIC= -22dBu, INPUT2= +10dBu | | | | |
| Maximum Analog Input Level | | INPUT1 : LINE: +24dBu, MIC: -8dBu, INPUT2 : +24dBu | | | | |
| Controls | | LEVEL x2, LINE/MIC, HPF, D-CONTOUR, THRU/MIX, POWER | | | | |
| Power Consumption | Idle | 18W | | | | |
| | 1/8 Power | 74W | | | | 60W |
| Power Requirements | | 100V, 110-120V, 220-240V, 110V/127V/220V(Brazil), 50/60Hz | | | | |

*1: Measured peak SPL with pink noise @1m.

*2: Total peak power of individual outputs (AC 120V, 25°C). This value was measured at minimum load impedance, with protection released.

*3: These values apply to XLR connectors.

| | | DBR15 | DBR12 | DBR10 | DXL1K |
|--|----------------------------|--|--|--|---|
| General | | | | | |
| System Type | | 2-way, Bi-amped Powered Speaker, Bass-reflex | | | Powered subwoofer with a line array speaker |
| Frequency Range (-10dB) | | 50Hz - 20kHz | 52Hz - 20kHz | 55Hz - 20kHz | 37 Hz - 20 kHz |
| Coverage Angle | | H90° x V60° | | | H170° x V30° |
| Crossover | Type | FIR-X tuning™ (Linear phase FIR filter) | | | |
| | Frequency | 2.1kHz | 2.1kHz | 2.1kHz | 240Hz |
| Maximum SPL*1 | | 132dB SPL | 131dB SPL | 129dB SPL | 125dB SPL |
| LF | Diameter | 15" Cone | 12" Cone | 10" Cone | 12" Cone |
| | Voice Coil | 2.5" | 2" | | 2.5" |
| | Magnet | Ferrite | | | Ferrite |
| HF | Diaphragm (DXL1K:Diameter) | 1.4" PET | | 1" PET | 1.5" Cone |
| | Type | 1" Throat Compression Driver | | | - |
| | Magnet | Ferrite | | | Cerium |
| Enclosure | | | | | |
| Material, Finish, Color | | Plastic, Black | | | Plastic, Black |
| Floor Monitor Angle | | 50° Symmetrical | | | 50° |
| Dimensions (W x H x D, with rubber feet) | | 455 x 700 x 378mm 17.9" x 27.6" x 14.9" | 376 x 601 x 348mm 14.8" x 23.7" x 13.7" | 308 x 493 x 289mm 12.1" x 19.4" x 11.4" | 334 x 2,000 x 418 mm 13.2" x 78.7" x 16.5" |
| Net Weight | | 19.3 kg (42.6 lbs) | 15.8 kg (34.8 lbs) | 10.5 kg (23.2 lbs) | 23.0 kg (50.7 lbs) |
| Handles | | Side x2 | | Top x1 | Top of powered subwoofer x 1 |
| Pole Socket | | Φ35 mm | | | |
| Rigging Points for eyebolts | | M8 x3 (Bottom x2, Rear x1, L:15mm) | | M8 x2 (Bottom x2, L:15mm) | - |
| Options | Speaker Bracket | - | - | - | - |
| | Speaker Cover | - | - | - | - |
| | Wheel Kit | - | - | - | - |
| Amplifier & DSP | | | | | |
| Amplifier Type | | Class-D | | | |
| Power Rating*1 | Dynamic*2 | 1000W (LF: 800W, HF: 200W) | | | 700W (LF: 500W, HF: 200W) |
| | Continuous | 465W (LF: 400W, HF: 65W) | | | 325W (LF: 260W, HF: 65W) |
| Cooling | | Fan cooling, 4 speeds | | | |
| AD/DA | | 24 bit / 48 kHz Sampling | | | |
| HPF/LPF | | OFF, 100, 120Hz 24dB/oct HPF | | | |
| DSP control, preset | | D-CONTOUR (FOH/MAIN, MONITOR, OFF) | | | |
| Protection | Speaker | Clip limiting, Integral Power Protection, DC-fault | | | |
| | Amplifier | Thermal, Output over current | | | |
| | Power Supply | Thermal, Output over voltage, Output over current | | | |
| Connectors | Analog Input | INPUT1: Combo x1, INPUT2: Combo x1 + RCA-pin x2 (Unbalanced) | | | |
| | Analog Output | XLR3-32 x 1 (CH1 Parallel Through or CH1+CH2 Mix) | | | |
| | AC IN | IEC AC inlet x1 | | | |
| Analog Input Impedance | | INPUT1: LINE= 12kΩ / MIC= 8kΩ, INPUT2&3: L-R= 40kΩ, MONO= 20kΩ | | | |
| Analog Input Sensitivity | (LEVEL: Maximum) | INPUT1 : LINE= 0dBu / MIC= -32dBu, INPUT2= 0dBu | | | |
| | (LEVEL: Center) | INPUT1 : LINE= +10dBu / MIC= -22dBu, INPUT2= +10dBu | | | |
| Maximum Analog Input Level | | INPUT1 : LINE: +24dBu, MIC: -8dBu, INPUT2 : +24dBu | | | |
| Controls | | LEVEL x2, LINE/MIC, HPF, D-CONTOUR, THRU/MIX, POWER | | | |
| Power Consumption | Idle | 18W | | | |
| | 1/8 Power | 74W | | | 60W |
| Power Requirements | | 100V, 110-120V, 220-240V, 110V/127V/220V(Brazil), 50/60Hz | | | |

Optional Brackets

U Bracket



| Model | Compatible Speakers |
|--------------------|---------------------|
| UB-DZR10H/V | CZR10 |
| UB-DZR12H/V | CZR12 |
| UB-DZR15H/V | CZR15 |
| UB-DXR8 | DXR8 |
| UB-DXR10 | DXR10/DHR10 |
| UB-DXR12 | DXR12/DHR12 |
| UB-DXR15 | DXR15 |

*You can use the U-bracket in combination with optional brackets sold separately.
For more information, visit the following Yamaha Pro Audio website.
<https://www.yamahaproaudio.com/>

Functional Speaker Covers

Introducing Yamaha's newly designed functional speaker covers that allow use and protect your speakers from unfavorable weather conditions during outdoor performances, dusty and dirty warehouse storage, or the rigors of equipment transport on the road.

SPCVR-DZR315 on DZR315

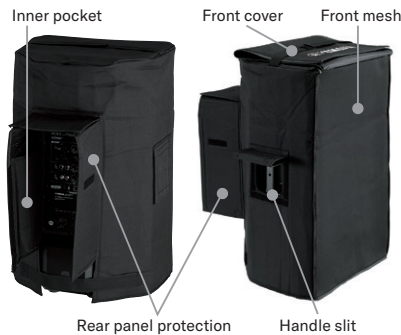

SPCVR-18S01 on DXS18



SPCVR-DXS18X on DXS18XLF



Trilaminar fabric

Reverse face Inner cushion

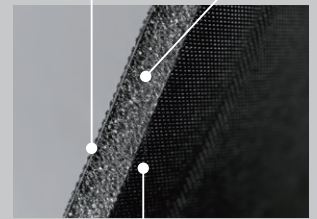

Polyester surface with PVC coating backside

Optional Wheel kit

For more fast and convenient setup of your subwoofers, optional wheels are available, featuring radial ball bearings that ensure quiet during your performance.

| Model | Compatible Speakers |
|--------------|---|
| SPW-1 | DXS18XLF/DXS18XLF-D, DXS15XLF/DXS15XLF-D, DXS18, DXS15mkII, DXS12mkII |



YAMAHA CORPORATION
P.O.BOX1, Hamamatsu Japan

<http://www.yamahaproaudio.com/>

*All specifications are subject to change without notice.
*All trademark and registered trademarks are property of their respective owners.